

This Owner's Manual is provided and hosted by [Appliance Factory Parts](http://Appliance Factory Parts).

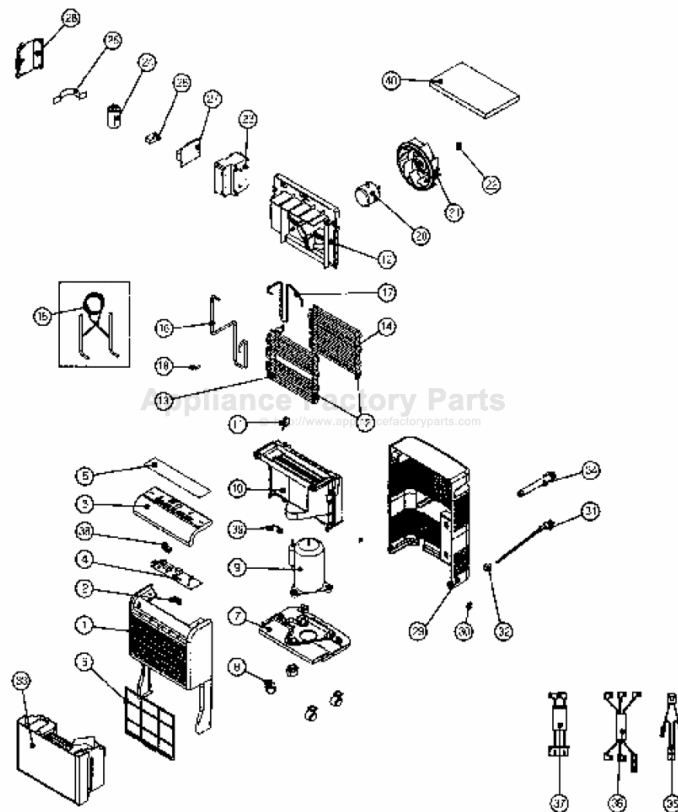

# Kenmore 251.50501010 Owner's Manual

[Shop genuine replacement parts for Kenmore  
251.50501010](#)



[Find Your Kenmore Dehumidifier Parts - Select From 135 Models](#)

----- Manual continues below -----

Use & Care Guide  
Manual de Uso y Cuidado  
Guide d'Utilisation et d'Entretien  
English / Español / Français



Models, Modelos, Modèles : 251.50351, 50501, 50701 (U.S.A.)  
251.25011, 25012, 25013 (Canada)

# Kenmore

## Dehumidifier

Deshumidificador  
Déshumidificateur

P/N J8000004380

Sears Brands Management  
Corporation, Hoffman Estates,  
IL 60179 USA

Sears Canada, Inc., Toronto,  
Ontario, Canada, M5B 2B8

[www.sears.com](http://www.sears.com)  
[www.sears.ca](http://www.sears.ca)



## TABLE OF CONTENTS

Package Contents.....	2	Control Panel.....	8.9
U.S. Warranty.....	2	Water Disposing Options.....	10
CANADA Warranty.....	3.4	Care and Maintenance.....	11
Safety Instructions.....	5	Troubleshooting.....	12
Electrical Requirements.....	6	Product Specification.....	13
Installation.....	6	Spanish/Español.....	14
Key Features.....	7	Sears Service.....	Back Cover

## PACKAGE CONTENTS

- Kenmore Dehumidifier
- Use & Care Guide

## U.S. WARRANTY

### Kenmore Limited Warranty

When installed, operated and maintained according to all instructions supplied with the product, if this appliance fails due to a defect in material and workmanship within one year from the date of purchase, call 1-800-4-MY-HOME® to arrange for free repair. If the sealed refrigerant system is defective within five years from the purchase date, call 1-800-4-MY-HOME® to arrange for free repair. All warranty coverage applies for only 90 days from the date of purchase if this product is ever used for other than private family purposes.

### This warranty covers only defects in material and workmanship. Sears will NOT pay for:

1. Expendable items that can wear out from normal use, including but not limited to filters, belts, light bulbs, and bags.
2. A service technician to instruct the user in correct product installation, operation or maintenance.
3. A service technician to clean or maintain this product.
4. Damage to or failure of this product if it is not installed, operated or maintained according to all the instructions supplied with the product.
5. Damage to or failure of this product resulting from accident, abuse, misuse or use for other than its intended purpose.
6. Damage to or failure of this product caused by the use of detergents, cleaners, chemicals or utensils other than those recommended in all instructions supplied with the product.
7. Damage to or failure of parts or systems resulting from unauthorized modifications made to this product.

### Disclaimer of implied warranties; limitation of remedies

Customer's sole and exclusive remedy under this limited warranty shall be product repair as provided herein. Implied warranties, including warranties of merchantability or fitness for a particular purpose, are limited to one year or the shortest period allowed by law. Sears shall not be liable for incidental or consequential damages. Some states and provinces do not allow the exclusion or limitation of incidental or consequential damages, or limitation on the duration of implied warranties of merchantability or fitness, so these exclusions or limitations may not apply to you.

This warranty applies only while this appliance is used in the United States or Canada. This warranty gives you specific legal rights, and you may also have other rights which vary from state to state.

Sears, Roebuck and Co., Hoffman Estates, IL 60179

## CANADA W

**General :** All models of Kenmore dehumidifiers materials or workmanship for a specific time period. Warranties extend to the original purchaser of the product and are not transferable. Purchases made through an online retailer at [www.sears.ca](http://www.sears.ca) are excluded. The relevant Warranty Period begins on the date of purchase. Within this period, Sears Canada, Inc. will repair or replace any products or components which fail in normal use. Repairs or replacements are made at no charge to the customer for parts or labor. Sears Canada, Inc. is not responsible for any transportation cost.

**Exclusions :** This warranty does not cover failure or damage caused by improper maintenance or failure to follow maintenance instructions to operate the product in accordance with the operating instructions information provided at the time of purchase or information provided by the purchaser, accident or unauthorized alterations. Exclusions from warranty coverage are the following:

1. "Wear Items", which are parts that will need to be replaced during the normal life of the product.
2. Service-related telephone calls or technician visits for instructions involving the correct product installation, operation of the product i.e. cleaning filters and the like.
3. Maintenance, adjustments, and cleaning instructions.
4. Damage or failure when installation, operation or maintenance instructions not followed.
5. Damage or failure resulting from accident, abuse, misuse or use for an intended purpose.
6. Damage or failure caused by the use of detergents, cleaners, chemicals or utensils other than those recommended in any instructions supplied with the product.
7. Damage or failure resulting from unauthorized modifications made to this product.

Any product missing the model and/or serial number will not be covered under this warranty.

**Repairs :** Repairs conducted within the Warranty Period are at the discretion of the original Warranty Period.

**Disclaimers :** The warranty and remedies contained herein are warranties, whether oral or written (Other than as required by law) or statutory, including but not limited to any liability limitation or fitness for a Particular purpose, statutory or common law. In no event shall Sears be liable for any incidental or consequential damages, whether resulting from the use, misuse or inability to use the products. The exclusions in this paragraph shall not apply for the exclusion of incidental or consequential damages. This paragraph shall not apply, but the remaining provisions of this paragraph shall not apply. Sears retains the exclusive right to repair or replace the product at its purchase price at its sole discretion. Such remedy shall not constitute any breach of warranty.

**Customer Responsibilities :** In addition to the operating instructions, guidelines and instructions, customers' obligation is to operate the product in accordance with the operating instructions information provided at the time of purchase or information provided by the purchaser from time to time, exhibit reasonable care in the use, operation and storage of the product. Failure to comply with the operating instructions shall void the warranty.

**Procedures :** Warranty service is available by calling 1-800-469-4663.

**List of Applicable Warranty Periods :** The following list contains the applicable Warranty Period for your Kenmore dehumidifier:

1. For one year from date of purchase, the cost of parts and labour for this product will be covered, free of charge if defective in material or workmanship.
2. For five years from date of purchase, the parts of the sealed system consisting of the compressor, evaporator, condenser and factory connected refrigerant tubing will be covered, free of charge if defective in material or workmanship.
3. If this appliance is ever used for other than private family/residential purposes, this warranty only applies for 30 days from the date of purchase.

**Service Type :** Kenmore dehumidifiers are serviced on a "carry-in" basis, whereby customer brings the unit to a Sears Retail or Product Repair Centre location.

**Proof of Purchase/Documentation :** Warranty coverage is conditioned upon the original purchaser furnishing Sears Canada or its authorized third party service provider if applicable, with the original sales receipt or other adequate written proof of the original purchase date and identification of the product. In the event that the original purchaser is unable to provide a copy of the original sales receipt, Sears Canada Inc. reserves the right to determine in its sole discretion what other written proof of the original purchase date and identification of the product is acceptable.

## IMPORTANT CAUTIONS FOR



To reduce the risk of fire, electrical dehumidifier, these safety precautions

### Safety

- Do not place the power cord near a heater.
- Do not use an electrical outlet near flammable or combustible materials such as gasoline, propane, paint thinners, etc.
- Do not disassemble or modify dehumidifier parts or components. It may cause electric shock and failure.
- Plug in the power cord properly.
- Do not turn the unit on and off by inserting or pulling out the power plug.
- Do not damage the power cord or use an unspecified power cord.
- Do not modify power cord length.
- Do not share the outlet with another appliance.
- Always plug into a grounded outlet. Not grounding unit may cause electrical shock.
- Unplug the unit if it emits strange sounds, odors, or smoke.
- Do not use an electrical outlet if it is loose or damaged.
- Do not operate or plug in unit with wet hands or in a wet environment.
- Ventilate area before operating dehumidifier. Check for the presence of natural gas or the buildup of other combustible vapors.
- Do not clean the dehumidifier with water. Water may enter the unit and degrade the insulation resulting in an electrical shock.
- If water enters the product, turn off the dehumidifier's power switch, then unplug the unit. Do not plug in unit until it has been inspected by an authorized repair service.
- Because the fan rotates at high speed during operation, always unplug dehumidifier before attempting any recommended maintenance or cleaning.
- Do not block the inlet or outlet. It may cause unit to fail or to operate inefficiently.

## ELECTRICAL REQUIREMENTS

**OBSERVE ALL LOCAL CODES AND ORDINANCES.**

**DO NOT, UNDER ANY CIRCUMSTANCES, REMOVE THE POWER SUPPLY CORD GROUND PRONG.**

**ELECTRICAL GROUND IS REQUIRED ON THIS APPLIANCE.**

**A 115-VOLT 60Hz, AC ONLY, 15A FUSED AND PROPERLY GROUNDED ELECTRICAL SUPPLY IS REQUIRED.**

A time delay fuse or time delay circuit breaker is recommended. Use a dedicated circuit serving only this appliance.

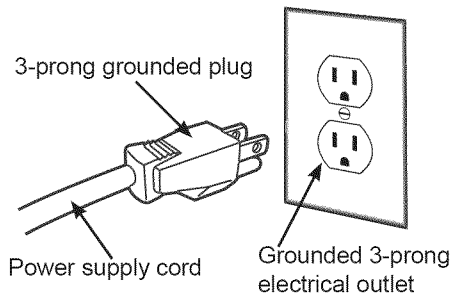

**DO NOT USE AN EXTENSION CORD.**

### RECOMMENDED GROUNDING METHOD

For your personal safety, this appliance must be grounded. This appliance has a power supply cord with a 3-prong grounded plug. To minimize possible shock hazard, the cord must be plugged into a matching grounded electrical outlet that complies with the latest edition of the National Electrical Code and all local codes and ordinances.

If a grounded 3-prong electrical outlet is not available, it is the personal responsibility and obligation of the customer to have one installed by a qualified electrician.



### ELECTRICAL SHOCK HAZARD

Plug into a grounded 3-prong outlet.

- Do not remove ground prong.
- Do not use a two-prong adapter.
- Do not use an extension cord.

Failure to follow these instructions can result in death, fire or electrical shock.

## INSTALLING YOUR DEHUMIDIFIER

- Install the dehumidifier on a level floor strong enough to support the unit with a full bucket of water.
- For best performance, allow at least 12-18 inches of air space on all sides of the unit for good air circulation.
- Keep all outside doors, windows and other openings closed when operating the dehumidifier. Humid outdoor air will add to the unit's workload.
- For maximum efficiency, install your dehumidifier in an area where the temperature will not fall below 65°F.

- Leave the dehumidifier in an upright position for 30 minutes before turning on.

### DEFROST OPERATION

The dehumidifier has a built-in defrost control that senses frost buildup on the evaporator coils.

During defrosting, the compressor will automatically turn off; the fan will continue running to defrost the coils.

## CHOOSING THE PROPER LOCATION

Use the dehumidifier:

- in the basement to help prevent moisture damage.
- in the kitchen, laundry room, bathroom, and spa/exercise areas that have excessive moisture.
- to prevent moisture damage anywhere books or valuables are stored.
- during construction or remodeling to reduce drying time for drywall and paint however check and clean filter often.

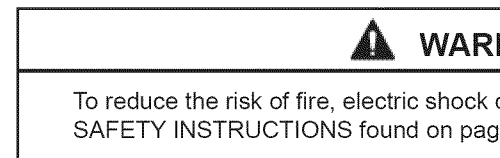

## KEY FEATURES OF YOUR DEHUMIDIFIER

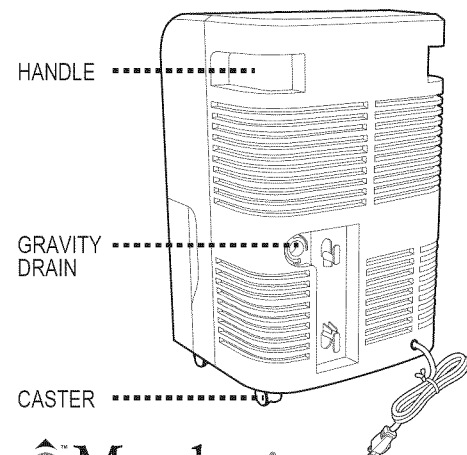

 **Microban®**  
antimicrobial product protection

Microban® antimicrobial protection inhibits the growth of odor causing bacteria on the dehumidifier Bucket. MICROBAN is a registered trademark of Microban Products Company.

Model : 50501/50701  
25012/25013

## CONTROL PANEL 50351 (U.S.), 25011 (CANADA)

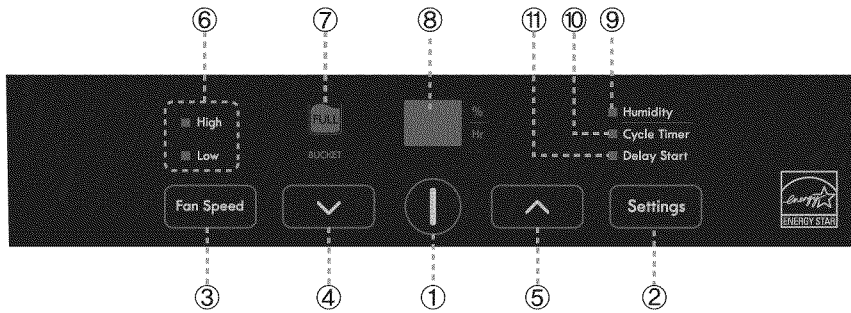

### POWER ON/OFF (1)

Pressing Power button once turns the dehumidifier “ON” and pressing it again turns the dehumidifier “OFF.”

### Setting (2)

By pressing this button, unit will cycle through each setting with every press. The order of settings are Humidity – Cycle Timer – Delay Start – Humidity ...

### Humidity (9)

When the unit is turned on, the unit will default to Humidity mode. In this setting, Humidity allows you to manually set the desired humidity level by using the humidity arrow or key (4/5). Humidity values are changed in 5% increments ranging from 35% to 70%. Humidity is shown in **window (8)**. When pressing **▼** arrow key when the value is 35%, the unit will operate continuously. In this continuous operation, **Lo** will be displayed in the **window (8)**. To leave continuous operation, press the arrow up or change the setting.

### Cycle Timer Setting (10)

In this setting, the unit will run for either 3, 6, or 12 hours, then shut off for 3, 6, or 12 hours. Cycle time can be adjusted by pushing the timer arrow up or down (4/5) repeatedly to set operating time for 3, 6, or 12 hours. The cycle timer function will continue until you change the setting or turn the unit off.

### Delay Start (11)

Unit can be programmed to turn on at a desired delay time by pushing the timer arrow and key (4/5). Time can be adjusted in 1 hour increments ranging from 1 to 12 hours. Delay time will be shown in **window (8)** and will count down to start time in 1 hour increments.

### FAN SPEED (3)

Press Fan Speed to toggle between Low and High fan speeds. Speed will be shown in **FAN SPEED INDICATOR (6)**.

### BUCKET FULL INDICATOR (7).

When the collection bucket is full, BUCKET FULL indicator (7) will come on. The dehumidifier will not run until the bucket is empty.

### IMPORTANT:

When the unit is turned off and restarted, the unit will operate at the previous operation setting.

### NOTICE:

A power failure will require the unit to be turned back on manually and adjusted to the desired setting.

## CONTROL PANEL 50501/50701

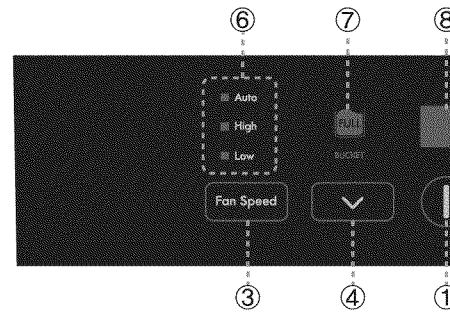

### POWER ON/OFF (1)

Pressing Power button once turns the dehumidifier “ON” and pressing it again turns the dehumidifier “OFF.”

### Setting (2)

By pressing this button, unit will cycle through each setting with every press. The order of settings are Auto – Humidity – Cycle Timer – Delay Start – Auto ...

### Auto (9)

When the unit is turned on, the unit will default to Auto mode. **AUTO (9)** and “50%” humidity value will be displayed in **window (8)**. In this setting, humidity level is automatically set for 50% RH. Because lower temperatures usually correlate with lower humidity levels, the unit will not run frequently. At higher temperatures higher humidity is normal so the unit will run more often.

### Humidity (9)

In this setting, Humidity allows you to manually set the desired humidity level by using the humidity **▼** arrow or key (4/5). Humidity values are changed in 5% increments ranging from 35% to 70%. Humidity is shown in **window (8)**. When pressing arrow key when the value is 35%, the unit will operate continuously. In this continuous operation, **Lo** will be displayed in the **window (8)**. To leave continuous operation, press the arrow up or change the setting.

## WATER DISPOSING OPTIONS

### OPTION 1. EMPTYING MANUALLY

1. Pull out the bucket, grasping side handles.
2. Carry the bucket by grasping the inside handle of the bucket.
3. After emptying the bucket, replace the bucket in the dehumidifier.

NOTE: Dehumidifier will not work when the BUCKET FULL light is on or without the bucket properly placed in the unit.

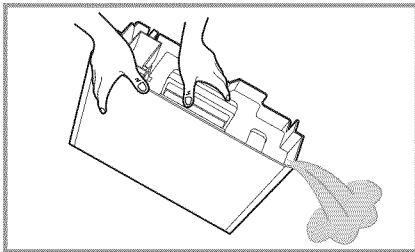
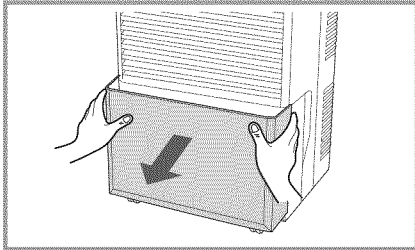

### OPTION 2. GRAVITY DRAIN HOSE

(Hose Not Provided)

1. Take off GRAVITY DRAIN Cap. (Fig.1)
2. Assemble the DRAIN CONNECTOR to the dehumidifier by turning clockwise. (Fig.2)
3. Next, Screw a standard drain hose to drain connector by turning clockwise. (Fig.3)

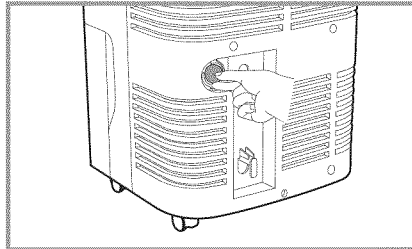

Fig.1

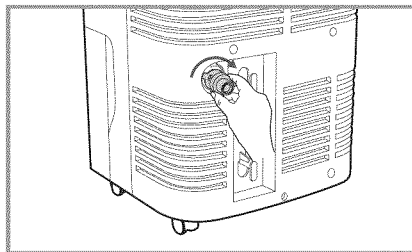

Fig.2

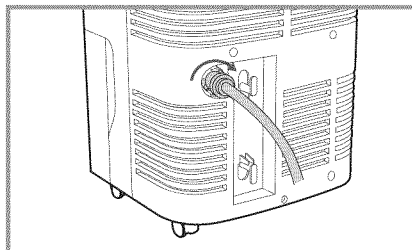

Fig.3

## CARE AND MAINTENANCE



### WARNING

- Disconnect power supply cord from receptacle before performing any maintenance.

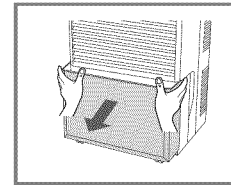

Fig.1

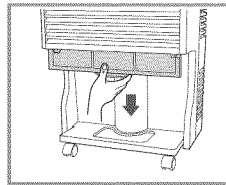

Fig.2

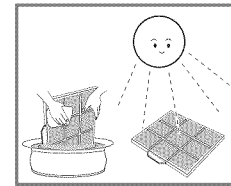

Fig.3

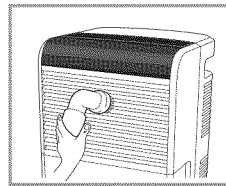

Fig.4

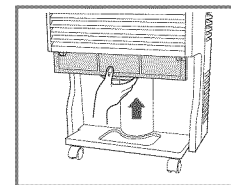

Fig.5

### CLEANING FRONT GRILL AND AIR FILTER

1. Remove the bucket from unit. Air filter is located behind front grill. (Fig.1)
2. Pull the filter down and away from unit until it is all the way out. (Fig.2)
3. Wash with mild detergent. Rinse thoroughly. Air dry away from direct sunlight. (Fig.3)
4. FRONT GRILL can be cleaned using a vacuum cleaner or a soft brush to remove dust. (Fig.4)
5. After cleaning, assemble the air filter to front grill. (Fig.5)

NOTE : Check your filter periodically to insure proper operation.

## TROUBLESHOOTING

Before calling for service, try the suggestions below to see whether you can solve your problem without outside help.

PROBLEMS	CHECK POINT	SOLUTIONS
Dehumidifier does not work when pressing the POWER ON button.	Is the power cord plugged into a grounded 3-prong outlet? Is BUCKET FULL light on? Does BUCKET FULL light appear after emptying the water bucket?	Plug the power cord securely into a grounded 3-prong outlet. Empty the water bucket and re-install. Check the float switch to make sure it is free and not obstructed.
Dehumidifier is operating, but the unit is not drawing any water	Is the compressor running as well as the fan?	The unit may be in the defrost mode. The fan is running but not the compressor. The unit will return to dehumidification automatically.
Loud noise and/or vibration during operation.	Is the unit on a level surface?	Move the unit to a level surface.
Sounds.	Sounds like flowing water during and after operation. It makes a pinging sound.	This is the normal sound of the refrigerant flowing through the coils. Normal sound of expansion and contraction caused by temperature changes.
Dehumidifier is not running efficiently	Are the filter and grill dirty? Is indoor temperature under 65°F?	Clean the FRONT GRILL and AIR FILTER. Although the unit will dehumidify at temperatures below 65 degrees, there is a potential for frost to develop which may inhibit the unit's efficiency
Unit is discharging warm air.		Normal: Compressor and electric motor discharge a small amount of heat.
Water does not drain through hose.	Check the DRAIN CONNECTOR. Is it installed correctly? Check the drain hose for kinks or obstructions.	Re-install drain hose according to this manual. Flatten the hose or remove blockage.

## PRODUCT SPECIFICATIONS

Classification	Specifications	
Model	50351	50352
Power Supply	AC 115V/60Hz	AC 115V/60Hz
Moisture Removal	35 Pint (16.5liters)	50 Pint (23.5liters)
Control Type	Electronic	Electronic
Refrigerant	R-410a 8.46 OZ(240g)	R-410a 10.58 OZ(300g)
Humidity Setting	LO, 35-70%	LO, 35-70%
Cycle Timer	3, 6, 12 Hours	3, 6, 12 Hours
Delay Time		1-12 Hours
Fan Motor Speed	2 Stages:High,Low	Auto,High,Low
Operating Temp.	36°F-99°F	36°F-99°F
Dimensions	13.0X20.9X9.3 in	14.6X23.3X10.1 in
	330X530X235 mm	370X590X260 mm
Net Weight	29.76 lbs (13.5Kg)	40.12 lbs (18.2Kg)
Bucket Capacity	10.6 Pint (5.0liters)	19.4 Pint (9.1liters)

# Get it fixed, at your home or ours!

## Your Home

For troubleshooting, product manuals and home solutions advice:

**manage my home**

[www.managemyhome.com](http://www.managemyhome.com)

For repair – **in your home** – of **all** major brand appliances, lawn and garden equipment, or heating and cooling systems, **no matter who made it, no matter who sold it!**

For the replacement parts, accessories and owner's manuals that you need to do-it-yourself.

For Sears professional installation of home appliances and items like garage door openers and water heaters.

**1-800-4-MY-HOME®**

(1-800-469-4663)

[www.sears.com](http://www.sears.com)

Call anytime, day or night

(U.S.A. and Canada)

[www.sears.ca](http://www.sears.ca)

## Our Home

For repair of carry-in items like vacuums, lawn equipment, and electronics, call anytime for the location of the nearest

**Sears Parts & Repair Service Center**

**1-800-488-1222** (U.S.A.)

[www.sears.com](http://www.sears.com)

**1-800-469-4663** (Canada)

[www.sears.ca](http://www.sears.ca)

To purchase a protection agreement on a product serviced by Sears:

**1-800-827-6655** (U.S.A.)

**1-800-361-6665** (Canada)

Para pedir servicio de reparación a domicilio, y para ordenar piezas:

**1-888-SU-HOGAR®**

(1-888-784-6427)

Au Canada pour service en français:

**1-800-LE-FOYER<sup>MC</sup>**

(1-800-533-6937)

[www.sears.ca](http://www.sears.ca)

# Sears

® Registered Trademark / <sup>TM</sup> Trademark of KCD IP, LLC in the United States, or Sears Brands, LLC in other countries

® Marca Registrada / <sup>TM</sup> Marca de Fábrica de KCD IP, LLC en Estados Unidos, o Sears Brands, LLC in otros países

<sup>MC</sup> Marque de commerce / <sup>MD</sup> Marque déposée de Sears Brands, LLC