



OWNER'S MANUAL

BBQLHS



RESIDENTIAL PELLET GRILL-SMOKER

**This Grill Protected Under Patent Numbers:
370,823 and 4,823,684**

FOR OUTDOOR USE ONLY!

WARNING!
**DO NOT STORE OR USE COMBUSTIBLE MATERIALS
NEAR THIS APPLIANCE!**

**USE ONLY TRAEGER BRAND HARDWOOD
BBQ PELLETS IN THE OPERATION OF THIS UNIT.**

“TASTE THE DIFFERENCE”

INTRODUCTION

Congratulations on your purchase of this Traeger Wood Pellet Grill, Model BBQPIG. With proper set-up, operation, and maintenance, the Grill will provide you with delicious food and years of cooking enjoyment.

NOTE: NUMBERS FOLLOWING PART NAMES REFER TO THE COMPONENT DIAGRAM FOUND NEAR THE END OF THIS MANUAL.

After removing the box from the Grill, remove all parts from inside the Grill. Remove any remaining packaging material from inside the Grill as well. Make sure you have, and can identify all of the following parts:

<u>Qty</u>	<u>Item Description</u>	<u>Component Diagram Reference Number</u>
(1)	Grill-----	2
(2)	Locking Casters-----	82
(2)	Castors-----	83
(1)	Heat Baffle-----	146
(1)	Grease Drain Pan-----	148
(1)	Porcelain Grill-----	151
(1)	Grease Bucket-----	153
(1)	Tail-----	94
(2)	Horns-----	95

You will need to complete the assembly process by:

- 1) Removing the Shipping Brackets
- 2) Installing the Casters (82, 83)
- 3) Positioning the Heat Baffle (146) over the Firepot (101)
- 4) Setting the Grease Drain Pan (148) over the Heat Baffle (146)
- 5) Placing the Porcelain Grill (151) on the Grill Supports.
- 6) Hanging the Grease Bucket (153) on the Bucket Hook.
- 7) Installing the horns.(95)
- 8) Installing the tail.(94)

TOOLS REQUIRED FOR ASSEMBLY:

One each 7/16" socket / driver or wrench is required.
One each 1/4" socket / driver or wrench is required.

Follow these step by step instructions and you will be cooking in no time!

SECTION ONE: ASSEMBLY INSTRUCTIONS

REMOVING THE SHIPPING BRACKETS:

Remove the four Shipping Brackets securing the Grill to the pallet using your 1/4" socket / driver or wrench.

INSTALLING THE CASTERS:

This process will be much easier and safer if you have another person to help.

Carefully lay the Grill on its back on a non-abrasive surface. Install the four Casters by following the diagram below: The Locking Casters (82) are to be located on the **front** of the Grill (Door Side). Firmly seat each Caster Pin into a Receptacle. With your helper, stand the Grill upright.

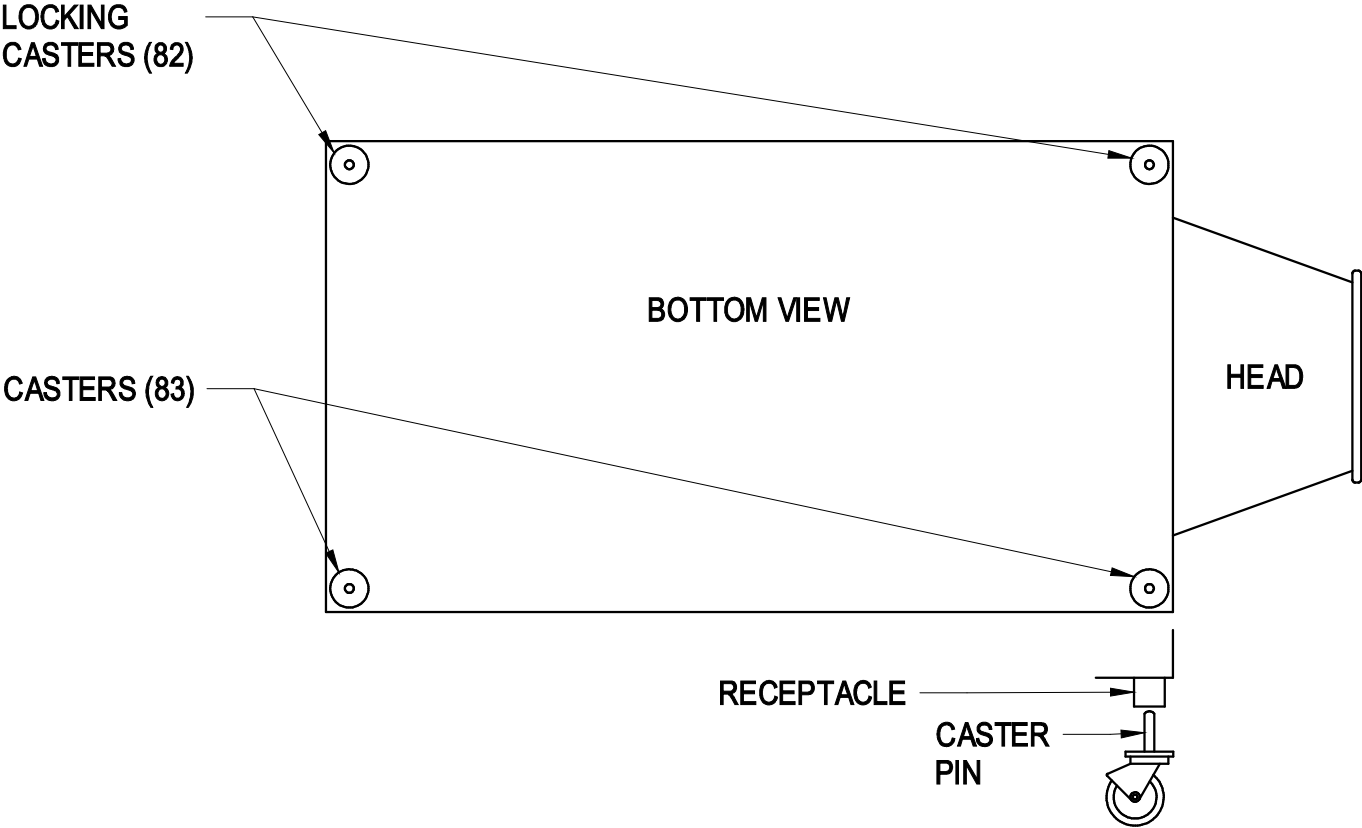

INSTALLING THE HORNS:

Insert the horn (95) onto the tube and align with the hole in the steer head tube as shown.

Secure using 1/4-20 x .75 hex bolt (96). Repeat the process on the other side.
See figure 1.

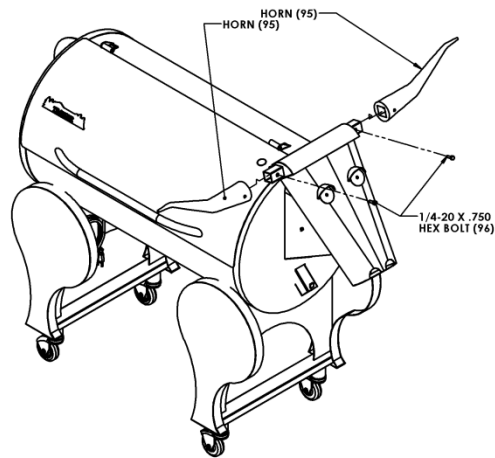

Figure 1

INSTALLING THE TAIL:

Insert tail onto the back of the steer and align with threaded holes.
Secure using 2 each 1/4-20 x .750 hex bolts (96).



NOTE: If at this point you are ready to start your Grill, refer to the **INITIAL FIRING INSTRUCTIONS** in **SECTION TWO** of this manual or on a separate sheet in the **PELLET HOPPER** before proceeding with further assembly.

WARNING!

Many parts of the Grill will become very *hot* during operation. Care must be taken to avoid burns, both during operation and afterwards, while the Grill is still hot. It should *never* be left unattended when young children are present. *Never* move the Grill when it is operating. Let it thoroughly cool before moving or attempting to transport.

POSITIONING THE HEAT BAFFLE:

Position The Heat Baffle (146) directly over the Firepot (101) on the two locating brackets found on the inside walls of the Grill. The notched legs of the Heat Baffle (146) should be pointing downward to fit onto the locating brackets.

POSITIONING THE GREASE DRAIN PAN:

RECOMMENDATION for ease of clean-up: Line the Grease Drain Pan (148) with heavy-duty aluminum foil. Be sure the edges and ends of the foil are tight against the bottom of the Grease Drain Pan (148).

Position the Grease Drain Pan (148) so that the Short Lip end hooks over the Grease Drain Pan Support (152). The Long Lip end should rest in the V-Shaped Grease Drain located inside the Grill on the right.

POSITIONING THE PORCELAIN GRILL:

Position the Porcelain Grill (151) on the Grill Supports that run the length of the cooking area.

HANGING THE GREASE BUCKET:

Locate the Grease Drain Tube on the right end of the Grill beneath the head. Hang the Grease Bucket on the Bucket Hook.

SECTION TWO: INITIAL FIRING INSTRUCTIONS

(To be used on initial firing or anytime the Grill runs out of Pellets)

In order to ensure proper operation of the Grill, you must first allow the Auger Tube to be “charged” with Pellets.

- 1) Open the Door and remove the Porcelain Grill, Grease Drain Pan and Heat Baffle from inside the Grill.
- 2) Make sure the Switch is in the OFF (o) position. Plug the Power Cord into an appropriate, grounded electrical outlet.
- 3) Open the Pellet Hopper Lid and locate the Auger. Make sure there are no foreign objects in the Auger. Turn the Switch ON (→) and the Temperature/dial to smoke look into the Pellet Hopper to confirm the Auger is turning. At the same time, place your fingers over the Firepot and feel the air movement from the Draft Inducer Fan. Look to see if the Hot Rod is getting hot (it will start to turn red). **CAUTION! Do not touch it.** Turn the Temperature/dial to SHUT DOWN CYCLE.
- 4) Fill the Pellet Hopper with TRAEGER BBQ PELLETS. **WARNING! Use only TRAEGER BRAND BBQ PELLETS, which are specifically made to work in our Grills. Never use heating fuel pellets in the Grill.** Turn the Temperature/Dial to HIGH. Note: During the initial charging of the Auger, it will take time for the Pellets to travel from the Pellet Hopper to the Firepot. When the Pellets begin to fall into the Firepot, turn the Temperature/Dial to Shut Down Cycle.
- 5) Set the Temperature/Dial to SMOKE. Let the Pellets come to full flame. Once you see flames come out of the Firepot, turn the Temperature/Dial to SHUT DOWN CYCLE, and let the Grill cool down.
Recommendation: For ease of clean-up, line the Grease Drain Pan with heavy-duty aluminum foil. Be sure the edges and ends of the foil are tight against the bottom of the Grease Drain Pan. Position the Heat Baffle, The foil lined Grease Drain Pan and Porcelain Grill in their proper locations.
- 6) With the Door open set the Temperature/Dial to SMOKE. In approximately 2 minutes you will notice whitish-gray smoke coming out of the Grill as the Pellets ignite. After assuring the Pellets have ignited, close the Door and set the Temperature/Dial to any cooking setting desired.
- 7) **Note: Before cooking the first batch of food in your new Grill, you will need to season the Grill. Turn the Temperature/Dial to HIGH and run for 45 minutes at this setting with the Door closed. This must be done before cooking any food on the Grill.**
- 8) The Grill should be allowed to preheat for approximately 10 minutes with the Door closed before placing food in the grill.

WARNING! START THE GRILL ON SMOKE SETTING WITH THE DOOR OPEN

**Once the Pellets are ignited, close the Door and
set the Temperature Dial to any cooking temperature desired.**

**WARNING! When operating this Grill, maintain a minimum
clearance of 12 inches from Grill to combustibles**

SECTION THREE: SUBSEQUENT START-UP

With the Door open, turn the Switch ON (--) and the Temperature/Dial to SMOKE. In approximately 2 minutes you will notice whitish-gray smoke coming out of the Grill as the Pellets ignite. After assuring the Pellets have ignited, close the Door and set the Temperature/Dial to any cooking setting desired. The Grill should be allowed to pre-heat for approximately 10 minutes with the Door closed before placing food in the Grill.

WARNING! If at any time, the Grill fails to light or the fire in the Firepot goes out while cooking or smoking, when sufficient pellets are still in the Pellet Hopper, it is important to follow these steps. Failure to do so may cause a hazardous “over-firing” of your grill due to an excess of unburned pellets in the Firepot.

- 1) **DANGER!** Turn the Switch OFF (o) and disconnect the Power Cord. If the Grill is still hot, allow it to thoroughly cool. Open the Door and remove all food, the Porcelain Grill, Grease Drain Pan and the Heat Baffle.
- 2) **WARNING!** Remove all unburned pellets and ash from inside and around the Firepot. (**See instructions for proper handling and disposal of ash in Section Five**)
- 3) Before replacing the Heat Baffle, Grease Drain Pan and the Porcelain Grill, plug the power Cord into an appropriate, grounded electrical outlet and restart the Grill. Pellets should fall into the Firepot and the Hot Rod should begin to heat (it will start to turn red). **CAUTION! Do not touch it.**
- 4) If this procedure **is** successful, you will soon see flames come out of the Firepot. Then turn the Switch OFF (o), and let the Grill cool down. Position the Heat Baffle, the Grease Drain Pan and Porcelain Grill in their proper locations. With the Door open, turn the Switch ON (--) and the Temperature/Dial to SMOKE. In approximately 2 minutes you will notice whitish-gray smoke coming out of the Grill as the Pellets ignite. After assuring the Pellets have ignited, close the Door and set the temperature/Dial to any cooking setting desired.
- 5) If this procedure **is not** successful, see **Section Six: FREQUENTLY ASKED QUESTIONS** for troubleshooting tips or contact Traeger Technical Support (**Section Seven**) to help diagnose the problem **before** proceeding to the **MANUAL LIGHTING INSTRUCTIONS** below.

MANUAL LIGHTING INSTRUCTIONS:

If the **Hot Rod** only is not operating, the Grill can still be used to cook and smoke using the **MANUAL LIGHTING PROCEDURE** below:

- 1) **DANGER!** Turn the Switch OFF (o) and disconnect the Power Cord. Allow the Grill to thoroughly cool if it is still hot. From beneath the Pellet Hopper, disconnect the Hot Rod (Purple / White wire pair as shown in the wiring diagram near the end of this manual). You will need to remove the Hopper Bottom Panel to access the wiring. Once the Hot Rod is disconnected, replace the Hopper Bottom Panel and plug the Power Cord back into an appropriate, grounded electrical outlet.
- 2) Open the Pellet Hopper and fill with TRAEGER BBQ PELLETS.

WARNING! USE ONLY TRAEGER BRAND BBQ WOOD PELLETS, which are specifically made to work in our Grills. NEVER use heating fuel pellets in the

Grill due to potential hazardous contaminants and additives that may be present.

- 3) Remove the Porcelain Grill, Grease Drain Pan and Heat Baffle to expose the Firepot In the bottom of the Grill.
- 4) Pour 1/2 cup of TRAEGER BBQ PELLETS into the Firepot.
- 5) Squirt 2 tablespoons of Alcohol Gel fire lighter into the Firepot on top of the Pellets.

DANGER! Never use gasoline, gasoline-type lantern fuel, kerosene, charcoal lighter fluid or similar liquids to start or “freshen up” a fire in this Grill. Keep all such liquids well away from the Grill when in use.

- 6) Carefully light the Alcohol Gel with a fireplace match or a long-reach butane lighter.

DANGER! Never squirt Alcohol Gel into a burning fire or a hot Firepot. The Alcohol Gel bottle could explode and cause a fire, serious injury or death.

- 7) Let the Alcohol Gel and Pellets burn for approximately 4 minutes.

- 8) After assuring the Pellets have ignited, install the Heat Baffle, Grease Drain Pan and Porcelain Grill back in place.

CAUTION! You will now have a fire in the Firepot. **Be careful not to burn yourself** when you install these components. Gloves are recommended.

- 9) Turn the Switch ON (--) and the Temperature/Dial to any setting desired. With the Door closed, let the Grill pre-heat for approximately 10 minutes before placing food in the Grill.

Control Shutdown cycle

The control for this barbecue comes with an automatic shut down cycle. When finished cooking on your barbecue set the Temperature/Dial Knob to the Shutdown Cycle position, this will leave the Draft Induction Fan running for ten minutes to burn any excess pellets in the fire pot. After the fan runs for ten minutes the controller will power off and the fan and it will stop running. **CAUTION!** The main power switch will shut the power off to the controller and the Temperature/Dial Knob switch will cut off power to the grill components only. When servicing the controller or any parts ensure that the power supply is disconnected to avoid a shock hazard.

SECTION FOUR: OPERATING TIPS

- 1) The Temperature Dial can be changed at any time to increase or decrease the cooking temperature of the Grill. The HIGH/HIGHER Temperature settings are for Grilling. The MED/MID RANGE Temperature settings are for Slow Cooking. The SMOKE setting is for Smoking and adding Smoke Flavor to foods being cooked. The SMOKE setting can also be used to “hold” foods at approximately 180 to 200 degrees F.
- 2) Your TRAEGER PELLET GRILL should never be moved while it is hot. If you are transporting your Grill in a vehicle after cooking on it, make sure the fire is completely out and the Grill is COLD before placing it in any vehicle. NEVER put water into the Firepot. It will jam the Auger.
- 3) The TRAEGER PELLET GRILL is designed to operate with the Door CLOSED. Cooking with the Door open greatly lengthens your cooking time.
- 4) NEVER add Pellets by hand to a hot Firepot. This is dangerous and you may be seriously burned. If you run out of Pellets and lose your fire while cooking, let the Grill completely cool and start again with the **INITIAL FIRING INSTRUCTIONS**.
- 5) Make sure the Heat Baffle is properly seated on its locating brackets. The long lips of the Heat Baffle should be pointing down over the Firepot. If not seated properly, direct heat and flame could come up out of the Firepot and cause a grease fire in the Grill.
- 6) When estimating cooking times, the outside temperature will be an important factor. If it is hot outside, it will take less time for food to cook. If it is cold, wet or windy, it will take longer.
- 7) Grease fires are caused by not properly maintaining the Grill by failing to clean your Grease Drain Pan, V-shaped Grease Drain and Grease Drain Tube on a consistent basis. In the unlikely event of a grease fire while cooking, **TURN THE SWITCH/DIAL OFF and KEEP THE DOOR CLOSED** until the fire is completely out. Never keep the Door open during a grease fire. If it does not go out, lightly sprinkle baking soda on the fire. **Be careful not to burn yourself**. If this does not work, then carefully remove the food from the Grill. Then keep the Door closed until the fire is completely out. **Again, be careful not to burn yourself**. When the Grill is completely cool, remove the Porcelain Grill and replace the foil on the Grease Drain Pan. Clean any grease accumulation from the V-shaped Grease Drain and the Grease Drain Tube. Replace the Grease Drain Pan and the Porcelain Grill in their proper positions, restart the Grill and resume cooking.

SECTION FIVE: MAINTAINING YOUR NEW GRILL

- 1) Change the aluminum foil on the Grease Drain Pan frequently. Periodically, clean the grease out of the V-shaped Grease Drain and Grease Drain Tube and off of the interior surfaces of the Grill. Empty the Grease Bucket occasionally and line with aluminum foil for easy clean-up. It is easier to clean off accumulated grease when the Grill is warm. **BE CAREFUL NOT TO BURN YOURSELF**. If too much grease is allowed to build up on the Grease Drain Pan and in the V-shaped Grease Drain, or is allowed to plug the Grease Drain Tube, a grease fire could result. We recommend cleaning these locations regularly.
- 2) Outside surfaces: DO NOT use oven cleaner, abrasive cleansers or abrasive cleaning pads on the outside Grill surfaces. Use warm soapy water to cut the grease.

- 3) If the Grill is stored outside during the rainy season, care should be taken to ensure that water does not get into the Pellet Hopper. Wood pellets, when wet, expand greatly and will jam your Auger. **A TRAEGER GRILL COVER to protect the Grill is highly recommended! Covers are available from your Traeger Dealer, or log on to our Web Site – www.traegergrills.com.**
- 4) Depending on use, periodically remove the Porcelain Grill, Grease Drain Pan and Heat Baffle to clean the ash from in and around the Firepot. A shop-vac is handy for this chore. Make sure the Grill is COLD before starting this procedure.
- 5) We recommend keeping a long-handled cleaning brush near the Grill. After removing your food, give the Porcelain Grill a quick brushing. It takes only a minute and it will be ready the next time you want to use the Grill. **Be careful not to burn yourself.**

SECTION SIX: FREQUENTLY ASKED QUESTIONS

WHY WON'T MY GRILL IGNITE?

- 1) Verify power at the electrical outlet.
 - a) If Power Cord is connected to a GFI (Ground Fault Interrupter), check and reset if necessary.
 - b) Initiate startup.
Still no ignition – Proceed to step 2.
- 2) Disconnect Power Cord from electrical outlet.
 - a) Remove the Control and check the fuse on back. Replace the fuse if blown.
Reinstall the Control!
 - b) Unplug Hot Rod connector (Purple/White wire pair), plug Power Cord into an appropriate, grounded electrical outlet and turn the Switch/Dial ON. **NOTE: At this point the Grill will not ignite.**
 - c) Check the Draft Inducer Fan and the Auger Drive Motor for operation. If both are operating -- the Hot Rod needs to be replaced. If one or both are not operating, contact Traeger Technical Support (**SECTION SEVEN**) for additional troubleshooting help. Contact your Traeger Dealer or the Traeger Parts Department (**SECTION SEVEN**) to place an order.
- 3) If the problem is identified to be a failed Hot Rod, the Grill can still be used to cook and smoke by following the **MANUAL LIGHTING INSTRUCTIONS** in **SECTION THREE** of this OWNER'S MANUAL.

WHY ARE NO PELLETS BEING DELIVERED INTO THE FIREPOT?

- 1) Verify that there are Pellets in the Pellet Hopper. If this is the **INITIAL FIRING** or the Grill has run out of Pellets, allow sufficient time for the Pellets to travel from the Pellet Hopper to the Firepot (can take up to 7 minutes).
- 2) Initiate startup. See **INITIAL FIRING INSTRUCTIONS** in **SECTION TWO** of this OWNER'S MANUAL.

Still no Pellets in the Firepot – Proceed to step 3.

- 3) Disconnect Power Cord from electrical outlet.
 - a) Unplug the Auger Drive Motor (Red/White wire pair connector) and the Draft Inducer Fan (Orange/White wire pair connector).
 - b) Reconnect the Draft Inducer Fan to the Red/White wire pair and the Auger Drive Motor to the Orange/White pair.
 - c) Plug Power Cord into an appropriate, grounded electrical outlet and turn the Switch/Dial ON.
 - d) If the Auger Drive Motor **is** operating (check the small fan blade on the back of the motor), the problem is in the Three Speed or Digital Control, which will need to be replaced. Contact your Traeger Dealer or the Traeger Parts Department (**SECTION SEVEN**) to place an order.

- 4) If the Auger Drive Motor **is not** operating but the Draft Inducer Fan **is** operating, the problem is in the Auger system, which will need to be checked.
 - a) With the Switch/Dial OFF, locate the small fan blade on the back of the Auger Drive Motor.
 - b) While watching the fan blade, turn the Switch/Dial to ON. If the fan blade **does not** turn, turn the Switch/Dial to OFF. This indicates a defective Auger Drive Motor and it will need to be replaced. Contact your Traeger Dealer or the Traeger Parts Department (**SECTION SEVEN**) to place an order.
 - c) If the fan blade turns a bit and then stops, continue watching and turn the Switch/Dial to OFF. If the fan blade UNWINDS slightly, this indicates a jam in the Auger system which will need to be cleared.
 - d) Disconnect Power Cord from electrical outlet and remove Pellets from the Pellet Hopper. Check for foreign objects and wet/decomposed Pellets, both of which can cause a jam in the Auger system. The Auger will need to be removed to clear a jam in the Auger system. See “HOW DO I REMOVE THE AUGER IF IT JAMS?” section below.

HOW DO I REMOVE THE AUGER IF IT JAMS?

- 1) Remove any covers necessary to access the Auger Drive Motor.
- 2) Remove the screw connecting the Auger Drive Motor shaft to the Auger shaft and the screw retaining the Auger Bushing into the Auger Tube.
- 3) With a small pipe wrench or locking pliers on the Auger shaft, turn the Auger counter clockwise. It will turn hard until it breaks free, then the Auger will turn freely.
- 4) Remove the Auger and clean all Pellets, ash or foreign objects from the Auger, Auger Tube and Firepot. A shop-vac is ideal for this task.
- 5) Sand the outside surfaces of the auger with medium grit sandpaper. Check the inside of the Auger Tube and sand it if needed. Vacuum sanding grit out of the Auger Tube and Firepot when finished.
- 6) Reinstall the Auger Bushing and the Auger into the Auger Tube, making sure that the Auger rotates freely.
- 7) Re-attach the Auger shaft to the Auger Drive Motor shaft.

WHY DOES MY GRILL FIRE GO OUT ON “SMOKE” SETTING?

Excess ash in the Firepot may be the problem.

- 1) Open the Door and remove the Porcelain Grill, Grease Drain Pan and Heat Baffle from inside the Grill.
- 2) **IMPORTANT: Remove all unburned Pellets and ash from inside and around the Firepot.** A shop-vac is ideal for this task **CAUTION! ASSURE THAT THE GRILL IS COLD TO AVOID A FIRE FROM HOT ASH.**
- 3) Replace the Heat Baffle, Grease Drain Pan and the Porcelain Grill and initiate start-up procedure.
- 4) If this didn't remedy the problem, contact Traeger Technical Support (**SECTION SEVEN**) for additional troubleshooting help.

WITH THE TRAEGER DIGITAL CONTROL, WHAT DIAL SETTING IS RECOMMENDED FOR STARTING THE GRILL?

The auto-start procedure is the same for all Grill Controls. With the Door open, turn the Switch/Dial ON and Temperature Dial to SMOKE. In approximately 2 minutes you will notice whitish-gray smoke coming out of the Grill as the Pellets ignite. After assuring the Pellets have ignited, close the Door and set the Temperature Dial to any cooking setting desired.

HOW DO I PROTECT MY PAINT FINISH?

- 1) Use a protective Cover on the Grill and touch-up paint to repair any scratches. **A TRAEGER GRILL COVER to protect the Grill is highly recommended! Covers and touch-up paint are available from your Traeger Dealer, or log on to our Web Site – www.traegergrills.com.**
- 2) Every 90 days, use a high quality car wax on the outside surfaces of the Grill. **ONLY APPLY WAX TO A COLD GRILL.**

WHERE CAN I GET A NEW PART FOR MY GRILL?

Check with your Traeger Dealer. They may have the part in stock or can order the part for you. Or you can contact the Traeger Parts Department (**SECTION SEVEN**) to place an order. In either case, please provide your name, phone number, address, Model and Serial Number of the Grill (located on a label inside the Hopper Lid), along with the part identification number from the Component Diagram.

SECTION SEVEN: TRAEGER SUPPORT

Parts are identified by number on the following COMPONENT DIAGRAM PAGE. To order parts: Call, E-mail or write to your Traeger Dealer or Traeger Pellet Grills. Please provide your name, phone number, address, Model and Serial Number of the Grill (located on a label inside the Hopper Lid), along with the part identification number from the Component Diagram.

TRAEGER PELLET GRILLS, LLC.
9445 SW Ridder Road #310
Wilsonville, OR 97070

TRAEGER TECHNICAL SUPPORT
Available 7 Days a Week 5AM TO 7PM
Pacific Time

TRAEGER PARTS DEPARTMENT
Available Weekdays 8AM to 4:30PM
Pacific Time

TRAEGER SALES/ORDER DESK
Available Weekdays 8AM to 4:30PM
Pacific Time

TOLL-FREE TELEPHONE: 1-800-872-3437

E-mail: service@traegergrills.com
Website: www.traegergrills.com



TRAEGER®
WOOD PELLET GRILLS

BBQLHS COMPONENT DIAGRAM

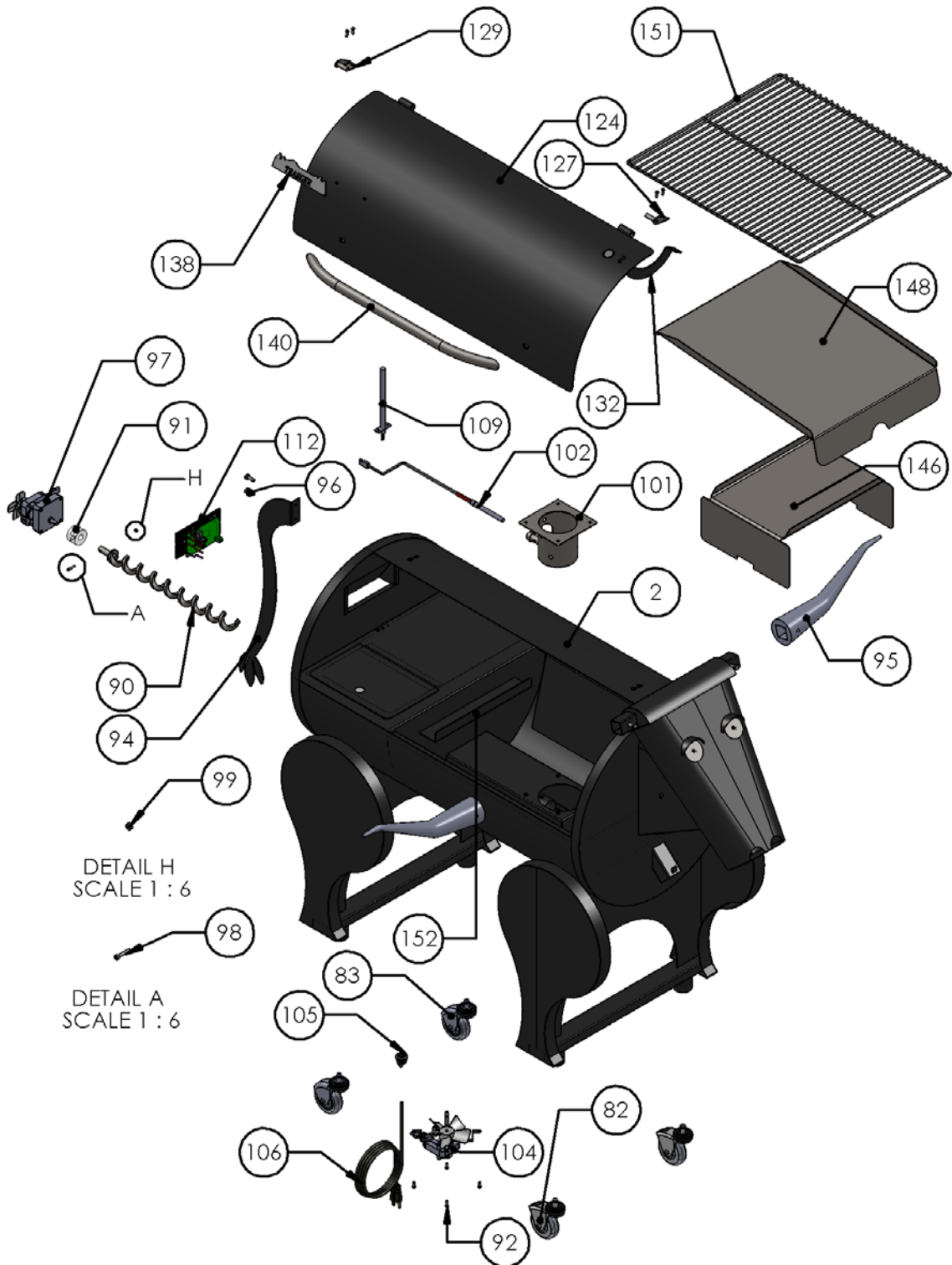

BBQLHS PARTS LIST

Item	Qty	Description	P/N
2	1	Grill Frame Assembly	SUB152
82	2	3" Caster with Brake	HDW302
83	2	3" Caster W/O Brake	HDW301
90	1	Auger Assembly	SUB094
91	1	Auger Bushing	BRN109
92	4	#8 X .500 Tek Screw	HDW119
94	1	Steer Tail	BCA092
95	2	Steer Horn	HDW230, HDW231
96	4	1/4-20 x .750 Hex Bolt	HDW137
97	1	Auger Drive Motor	BRN100
98	1	Screw 6-32 X .750 Socket Head	HDW116
99	1	Nut 6-32 Nylock Zinc	HDW112
101	1	Firepot Assembly 7 hole	FAB310
102	1	Hot Rod (Igniter)	BAC199
104	1	Draft Inducer Fan Assy	FAN209
105	1	Strain Relief	ELE210
106	1	Power Cord 8' Nema 120V	ELE203
109	1	7" RTD Sensor	BAC194
112	1	Digital Control W/ SDC	BAC283
124	1	Door	BCA214
127	1	Right Door Hinge Assembly	HDW221
129	1	Left Door Hinge Assembly	HDW222
132	1	Door Stop Arc	BCA002
138	1	Traeger Logo	HDW151
140	1	Door Handle 24"	HDW226
146	1	Heat Baffle	BCA012
148	1	Drain Pan	BCA005
151	1	Porcelain Grill	HDW195
152	1	Drip Pan Support	FCA002

DIGITAL THERMOSTAT CONTROL WIRING DIAGRAM

