

This Owner's Manual is provided and hosted by [Appliance Factory Parts](#).

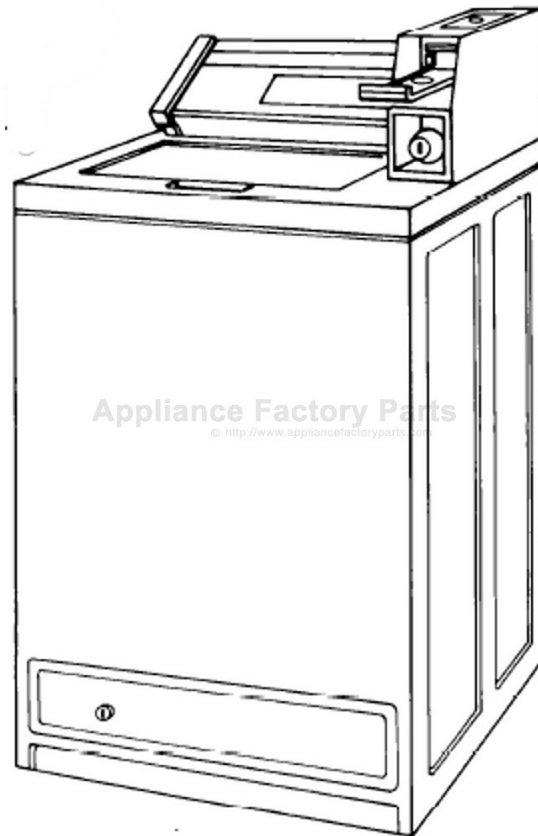

WHIRLPOOL GCA2781XSW0 Owner's Manual

[Shop genuine replacement parts for WHIRLPOOL
GCA2781XSW0](#)



[Find Your WHIRLPOOL Washer Parts - Select From 4132 Models](#)

----- Manual continues below -----

Installation Instructions



COMMERCIAL WASHER

120 volt, 60 Hz Models

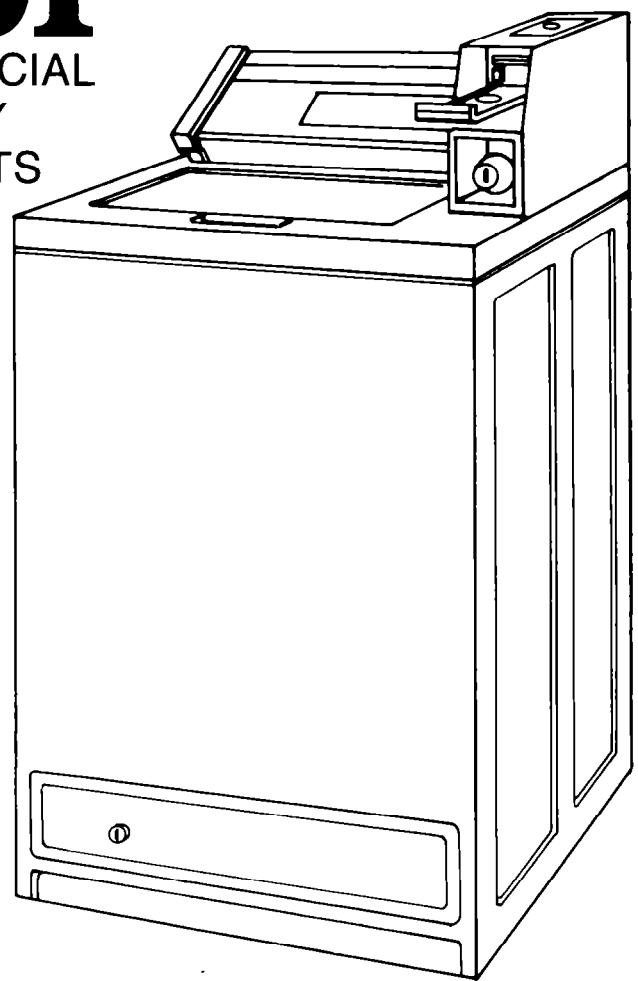

Automatic Washers, Clothes Dryers, Freezers, Refrigerator-Freezers, Ice Makers, Dishwashers, Built-In Ovens and Surface Units, Ranges, Microwave Ovens, Compactors, Room Air Conditioners, Dehumidifiers, Automatic Washers, Clothes Dr

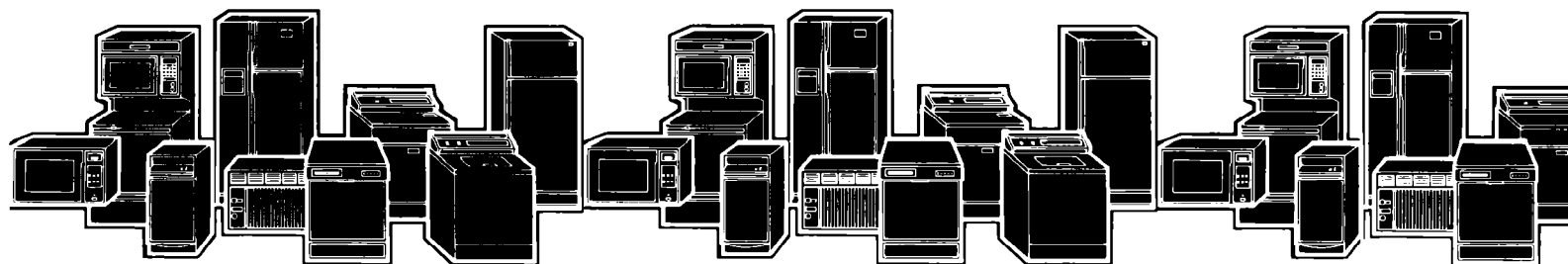

Before you start...

Check location where washer will be installed. Proper installation is your responsibility. Make sure you have everything necessary for correct installation.

Protection from weather: do not store or operate washer below 32°F.

Coin-operated washers are equipped with a meter case, console, timer, selector switches and indicator lights. The coin slide mechanism, slide mounting bolt, slide extension, service door panel lock and key, top lock and key, coin vault, and coin vault lock and key are not included with this washer and are needed to complete installation. These items are available from usual industry sources.

Hot and cold water faucets: must be within 4 feet of the back of the washer and provide water pressure 10-100 PSI. A pressure reduction valve should be used in the supply line where inlet pressure entering the building exceeds 100 PSI to prevent damage to the washer mixing valve.

Grounded electrical outlet: is required. See Electrical Requirements.

Single washer installations require 12" minimum risers to provide an air cushion and prevent noise and damage to valves.

Untape and open washer lid. Remove packages and hoses from washer.

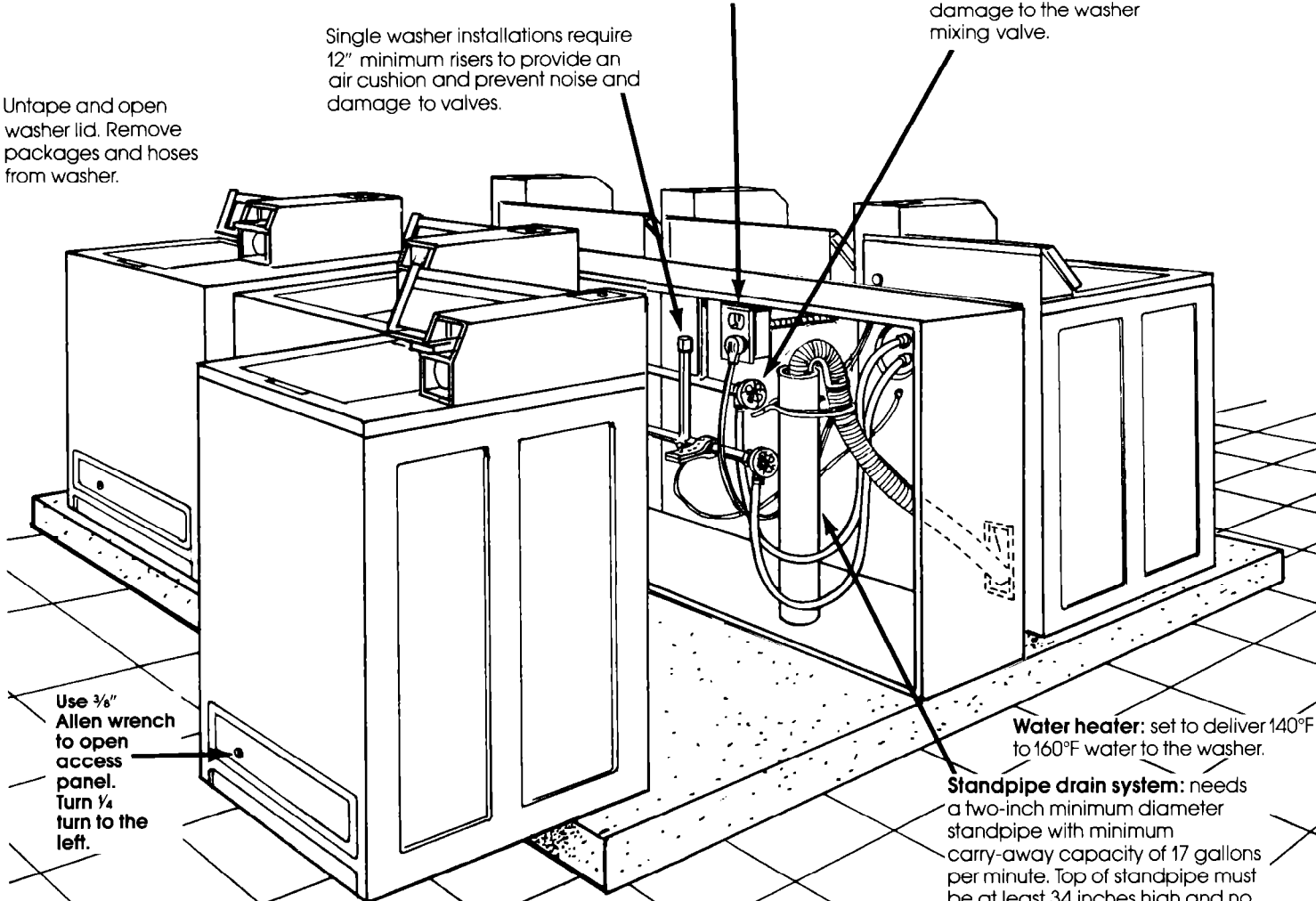

Use 3/8" Allen wrench to open access panel. Turn 1/4 turn to the left.

Front access to the pump area is available through the access door on coin operated washers. Non-coin operated washers do not have an access panel. The cabinet and top assembly must be removed by removing clips under console on the non-coin operated washer.

Non-coin operated washers are equipped with a console, push to start timer, selector switches and indicator lights. (not pictured)

Level floor: maximum slope under washer 1 inch.

A floor drain should be provided under the bulkhead. Prefabricated bulkheads with electrical outlets, water supply lines and drain facilities should be used only where local codes permit.

Water heater: set to deliver 140°F to 160°F water to the washer.

Standpipe drain system: needs a two-inch minimum diameter standpipe with minimum carry-away capacity of 17 gallons per minute. Top of standpipe must be at least 34 inches high and no higher than 72 inches from bottom of washer.

Support: floor must be sturdy enough to support loaded washer weight 315 pounds.

Important: observe all governing codes and ordinances.

Tools needed for installation.

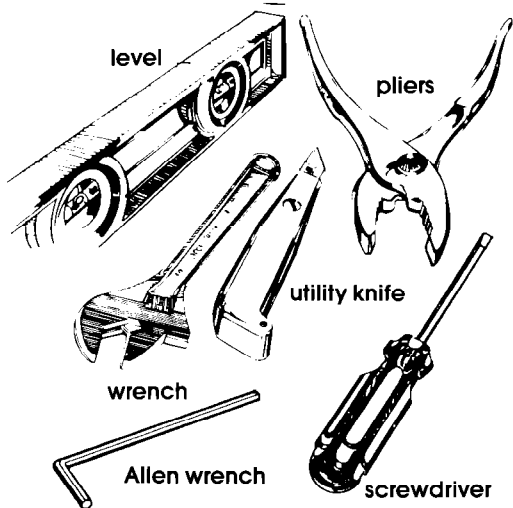

Parts supplied for installation.

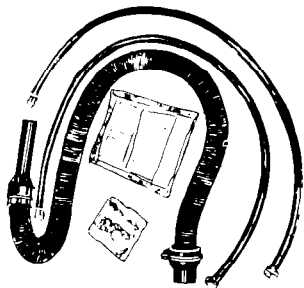

Remove parts from packages. Check that all parts were included.

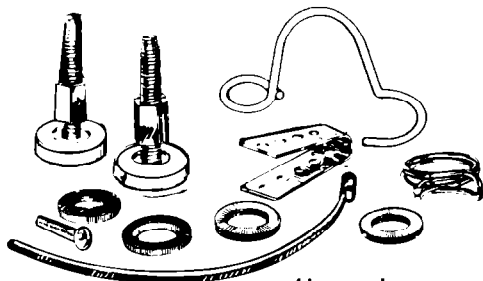

literature package
1 drain hose
1 plastic strap
grounding clamp and screw

1 hose clamp
2 inlet hoses
4 flat water hose washers
2 front leveling legs with nuts
1 wire form

Electrical requirements

A 120 Volt, 60 Hz, AC only, 15 Ampere fused electrical supply is required. (Time-delay fuse or circuit breaker is recommended.) It is recommended that a separate circuit serving only this appliance be provided.

WARNING: AN EXTENSION CORD SHOULD NOT BE USED WITH THIS APPLIANCE. SUCH USE MAY RESULT IN A FIRE, ELECTRICAL SHOCK OR OTHER PERSONAL INJURY.

PAGE 2

Recommended grounding method

DANGER: Improper connection of washer grounding-line conductor can result in a risk of electrical shock.

Do Not, under any circumstances remove the power supply cord grounding prong.

For your personal safety, this appliance must be grounded. This appliance is equipped with a power supply cord having a 3-prong grounding plug. To minimize possible shock hazard, the cord must be plugged into a mating 3-prong grounding type wall receptacle, grounding in accordance with National Electrical Code, ANSI/NFPA 70-1987 and local codes and ordinances. See Figure 1. If a mating wall receptacle is not available, it is the personal responsibility and obligation of the customer to have a properly grounded 3-prong wall receptacle installed by a qualified electrician. For added personal safety, use clamp and green colored copper grounding wire. Connect the grounding wire (#18 minimum) from the external grounding connector on the back of the washer to a grounded cold water pipe.* See Figure 2.

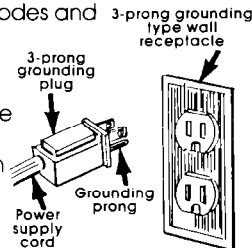

Figure 1

Do Not ground to a gas supply pipe or hot water pipe.

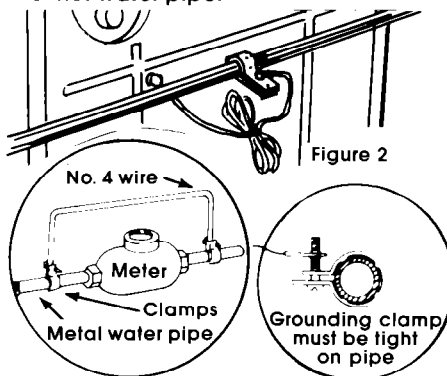

Figure 2

Electrical ground is required on this appliance.

* Grounded cold water pipe must have metal continuity to electrical ground and not be interrupted by plastic, rubber or other electrical insulating connectors such as hoses, fittings, washer or gaskets (including water meter or pump). Any electrical insulating connector should be jumped as shown in Figure 2 with No. 4 wire securely clamped to bare metal at both ends.

Alternate grounding method

Do Not, under any circumstances remove the power supply cord grounding prong.

If changing and properly grounding the wall receptacle is impossible and where local codes permit (consult your

electrical inspector), a temporary adaptor may be plugged into the existing 2-prong wall receptacle to mate with the 3-prong power supply cord. **THIS IS NOT RECOMMENDED.** If this is done, you **must** connect a separate copper grounding wire as (#18 minimum) to a grounded cold water pipe* by means of a clamp and then to the external grounding connector screw. Do not connect the power cord to outlet until the appliance is permanently grounded. See Figure 2.

Now Start...

With Washer in Laundry Area.

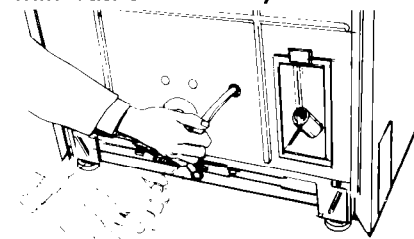

Pull the strap completely out of the washer.

1. Remove tape that covers shipping strap. Firmly jerk, then pull to completely remove the shipping strap from the inside of the washer. Read, then remove label that covers power cord and drain connector. Peel the tape down and off each side of cabinet.

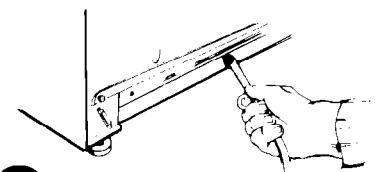

2. Pull firmly to remove the other end of the shipping strap from the back of the washer. The shipping strap plug must be completely removed from the washer for the self-leveling legs to be released. Discard shipping strap.

If entire strap is not removed, washer may vibrate and be noisy.

Use new hoses and washers that came with your Whirlpool washer.

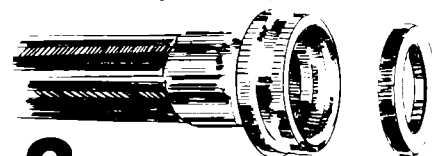

3. coupling washer

Insert a flat washer into **each** end of the inlet hoses. Check that washers are firmly seated in couplings.

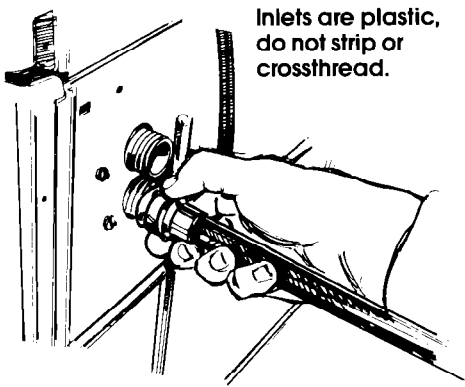

Inlets are plastic, do not strip or crossthread.

4. Attach hose to bottom inlet valve opening first. Then second hose to top inlet. Tighten couplings by hand, then use pliers to make an additional two-thirds turn.

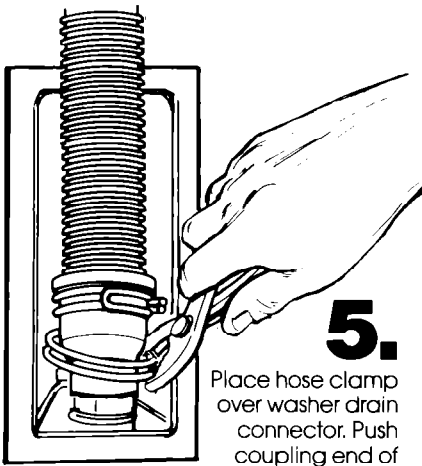

5. Place hose clamp over washer drain connector. Push coupling end of drain hose onto washer connector. Use pliers to open clamp and slide clamp over drain hose. Check for good fit.

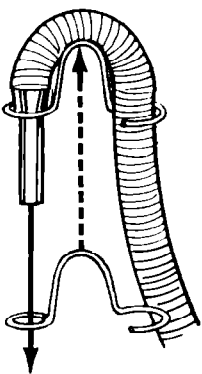

6. Slide nozzle end of drain hose through the **small "loop"** in the wire form. Wrap the hook end of the wire form around the drain hose to form a "hook shape."

7. Move washer close to final position. Put "hook" end of drain hose into standpipe. Check for proper length of drain hose.



8. If drain hose is too long – disconnect. Remove clamp and coupling. Estimate length of drain hose needed. Cut flexible end of hose. (**Do not cut hook-shaped end of drain hose.**) Push and twist coupling securely onto drain hose. (You should feel top of hose through coupling.) Slide clamp over coupling and hose. Reinstall drain hose. See step 5.

DO NOT FORCE EXCESS LENGTH OF DRAIN HOSE DOWN THE STANDPIPE. THIS COULD CAUSE SIPHONING.



9. Before attaching water inlet hoses, run water through both faucets to get rid of particles in water lines.

10.

Attach bottom hose (inlet marked "H") to hot water faucet. Attach top hose (inlet marked "C") to cold water faucet. Tighten coupling to faucet by hand, then use pliers to make final two-thirds turn.

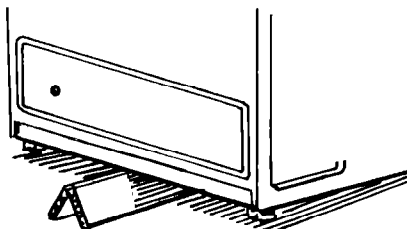

11. Carefully tilt washer backward until front of washer is 3-4 inches off of floor. Insert 1 or 2 corner posts.

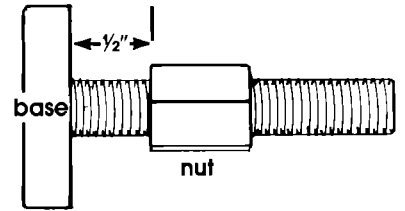

12. Use legs and nuts from parts package. Screw nut down to within $\frac{1}{2}$ " of base.

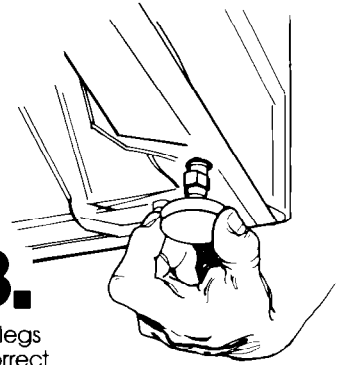

13. Screw legs into correct holes at each front corner of washer until nuts touch washer. **Do not** tighten nuts until step 16.

14.

Tilt washer backward and remove corner posts. Gently lower washer to floor.

Move washer to its permanent location.

Use caution when moving this appliance to prevent damage to floor coverings. Before moving, slide washer onto cardboard or hardboard to prevent floor damage.

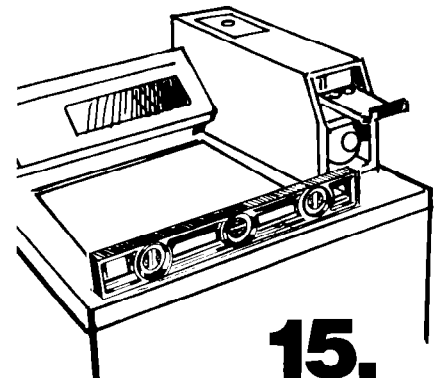

15. Tilt washer forward raising back legs 1" off of floor. Gently lower washer to floor. Check levelness at the washer front and from front to back on each side using a carpenter's level.



16.

If washer is not level, screw the front legs up or down to adjust. Make final check with level.

When washer is level, use wrench to turn nuts on front legs up tightly against washer base. If nuts are not tight against washer base, the washer may vibrate.

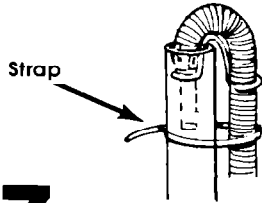

17.

Put "hook" end of drain hose in standpipe.

Secure drain hose by wrapping the plastic strap around the hose. Allow space between the standpipe and drain hose for an air gap. Too tight of a fit could cause siphoning.

CHECK THAT HOSE IS NOT TWISTED OR KINKED AND IS SECURELY IN PLACE.

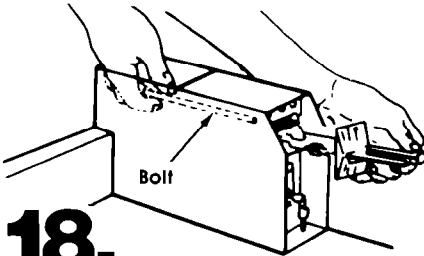

18.

On coin operated washers, remove the service door of the meter case. Lift the service door up at the back and remove. Carefully insert coin slide with the coin slide extension attached into front opening and secure with the 3/8" mounting bolt from inside the meter case. The coin slide may need to be partially pushed in to insert mechanism in the front opening. Replace meter case top and service door. Insert coin vault with lock and key.

19. CHECK ELECTRICAL REQUIREMENTS. BE SURE YOU HAVE CORRECT ELECTRICAL SUPPLY AND RECOMMENDED GROUNDING METHOD.

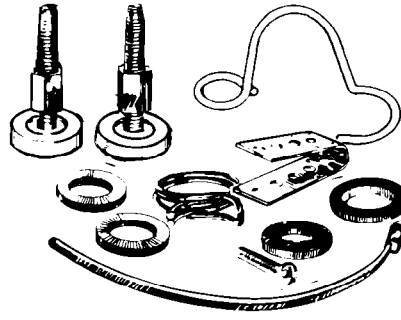

20.

Check that all parts are now installed. See parts list, Page 2. If there is an extra part, go back through steps to see which step was skipped.

21.

Turn on water faucets and check for leaks. Tighten couplings if there is leaking.

22.

Untape electrical cord and plug into grounded outlet.

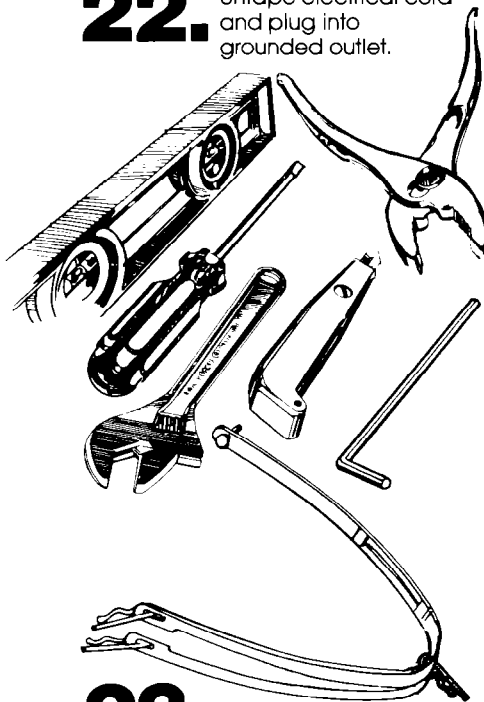

23.

Check that you have all tools that you started with and that the shipping strap with its 3 cotterpins and plug was removed from the washer.

If entire strap is not removed, washer may vibrate and be noisy.

24.

Check the wash cycle time. Both coin operated and non-coin operated washers have timers with a 9 minute wash in the Normal cycle. Remove the meter case top of coin operated washers to manually start the timer. Remove the rear of the console to manually operate the timer of non-coin operated washers. Start the washer and allow it to complete the Normal cycle.

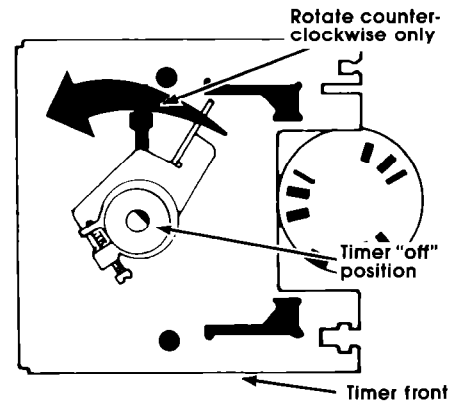

- Coin operated timers can be started by turning the clutch assembly counter-clockwise until the washer starts to fill with water.

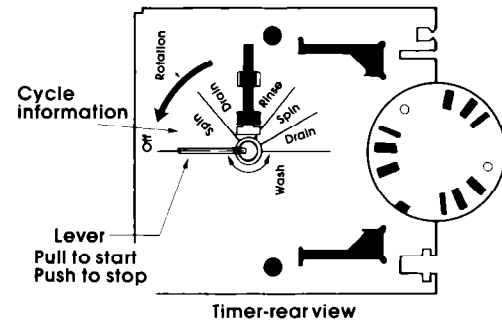

- Non-coin operated timer cycle information is ink stamped on the rear of the timer. Push in on the lever attached to the timer shaft. Reset lever to the Normal cycle position then pull out on lever to start washer.

25.

If the washer fails to start or does not give the proper wash cycle time, the clutch assembly of the coin operated can be adjusted. Remove the timer from the meter case. Adjust the clutch assembly screw clockwise. If the washer does not start after the coin slide mechanism has been fully actuated in or out. Adjust the clutch assembly screw counter-clockwise if the wash segment of the Normal cycle was less than 9 minutes.

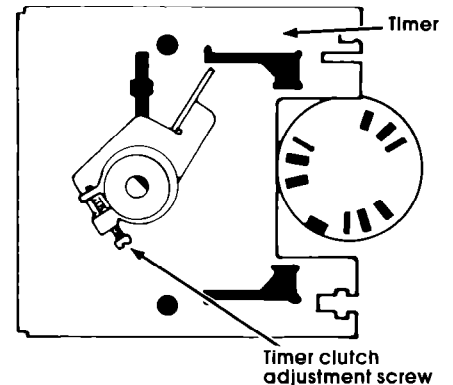

Owner options (coin operated models)

CAUTION: Disconnect power cord.

- For **EXTRA WASH** and/or **EXTRA SPIN**:
 - Remove meter case service door.
 - Loosen (2) screws on the timer mounting bracket and lift the timer out.

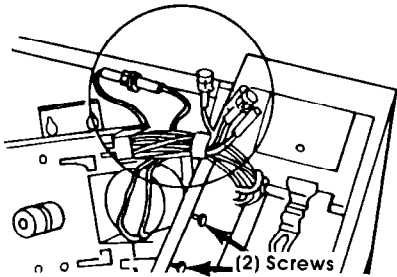

- EXTRA WASH** – 3 minutes.
 - Connect LBU to LBU2.
 - Disconnect GY from GY2.
 - Set timer clutch arm as shown below.

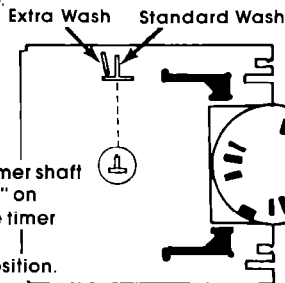

Leave "1" on timer shaft aligned with "1" on timer and move timer clutch arm to "extra" wash position.

- EXTRA SPIN** – 2 minutes.
 - Connect BK to BK2.
- For **WARM RINSE** and **WATER SAVER**:
 - Remove screws from each end of the console bottom.
 - Pull the console bottom forward; lift and tilt it back.
 - WARM RINSE**
 - Connect J1 to J2.
 - SAVE WATER**
 - Pull out tab on water-level switch.
 - If use of a larger coin vault, lock and key is desired, conversion bar in lower portion of coin vault area can be removed.
 - If additional security is needed, top and cabinet can be locked to washer back panel by using a "screw type" lock and key in space provided in top panel under console. The "screw type" lock and key are available from usual industry sources.

Typical full load sizes.

Load Type	Loading Suggestion	Load Type	Loading Suggestion
Mixed Load	3 double sheets 4 pillowcases 8 T-shirts 6 pair shorts 2 shirts 2 blouses 8 handkerchiefs	Heavy work clothes	3 pair pants 3 shirts 1 coverall 4 pair jeans 1 overall
Permanent Press	2 double or 1 king size sheet 1 tablecloth 1 dress 1 blouse 2 slacks 3 shirts 2 pillowcases	Knits	3 blouses 4 slacks 6 shirts 4 tops 4 dresses

Check list for washer operation.

Check the following if the washer is not operating properly:

- Power cord is plugged in.
- Circuit breakers are not tripped or fuses blown.
- Timer has been advanced to start of a cycle.
- Water faucets are turned on.
- Inlet and drain hoses are not kinked.
- Washer lid is closed.
- Inlet valve is frozen if not protected from the weather.
- Suds level. Excess suds will slow the spin and cause poor rinsing. Operate the washer through a complete cycle with no detergent. Use less detergent or a controlled suds type detergent in future loads.

Operating Precautions.

It is recommended that fiberglass items not be washed in coin operated washers. If these type items are washed in the washer, run the washer through a complete cycle to rinse any residue away that might be left in the washer.

Do Not use drycleaning fluids or other flammable solvents in this washer.

Moving the washer to a new location...

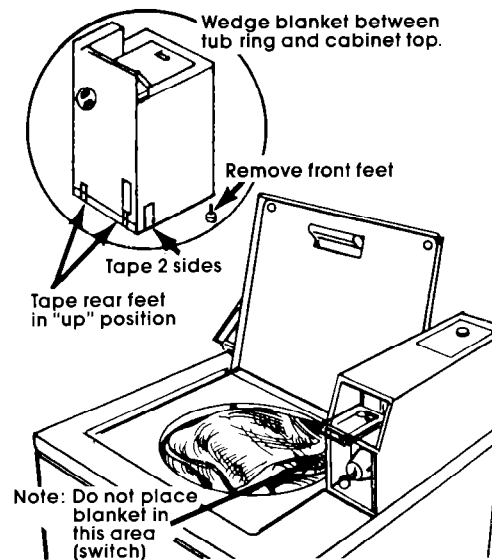

- Remove the front feet from the base of the washer.
- Place both rear leveling legs on the upper position and tape securely.
- Apply tape to the side and bottom of the cabinet near the rear.
- Open washer lid, wedge a blanket between the tub ring and the cabinet top restricting the tub movement.
- Handle washer carefully. **Do Not drop washer while using hand truck.**

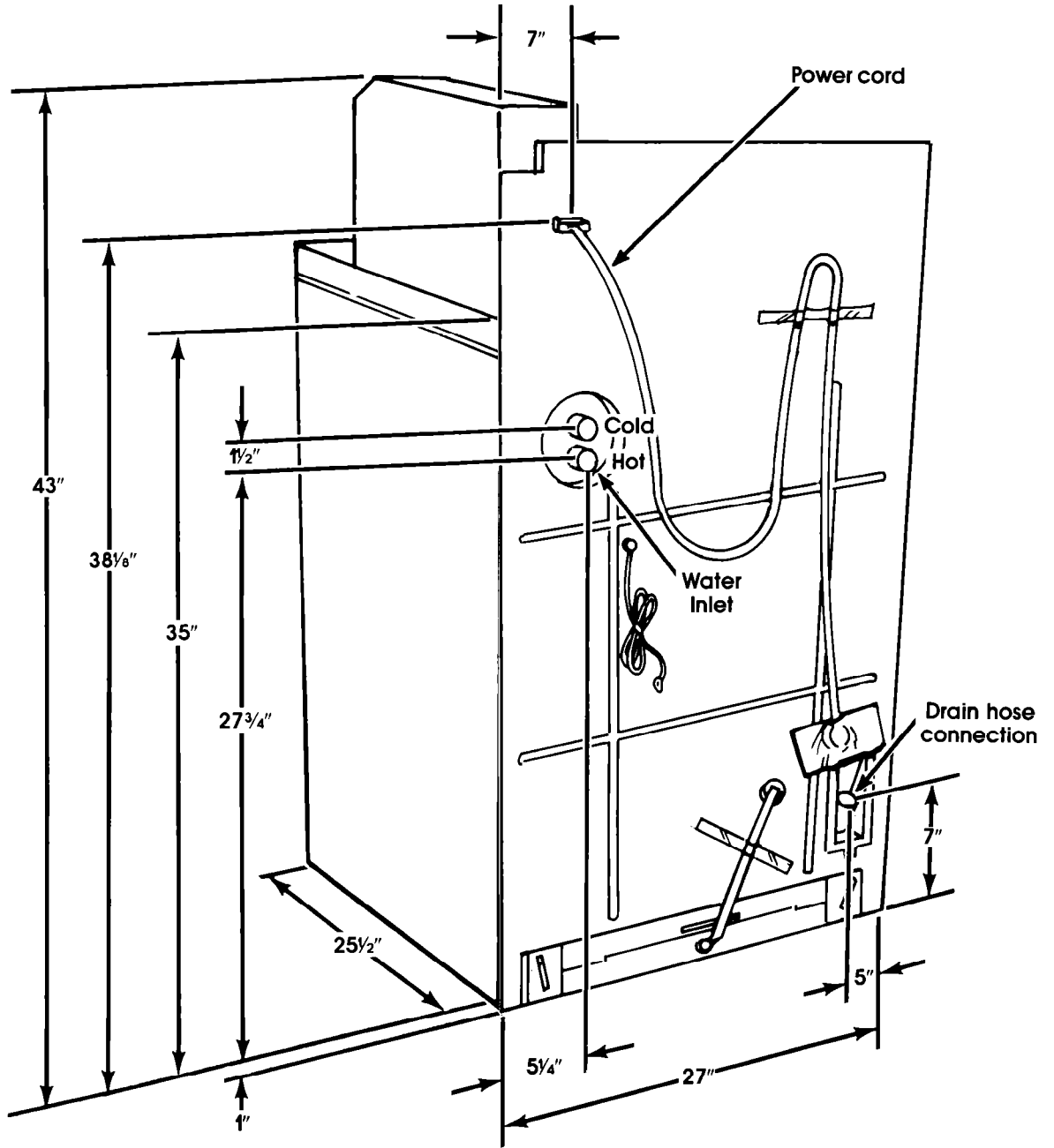



Part No. 3349739

Prepared by Whirlpool Corporation, Benton Harbor, Michigan 49022

Printed in U.S.A.

D 1207