

This Owner's Manual is provided and hosted by [Appliance Factory Parts](http://Appliance Factory Parts).

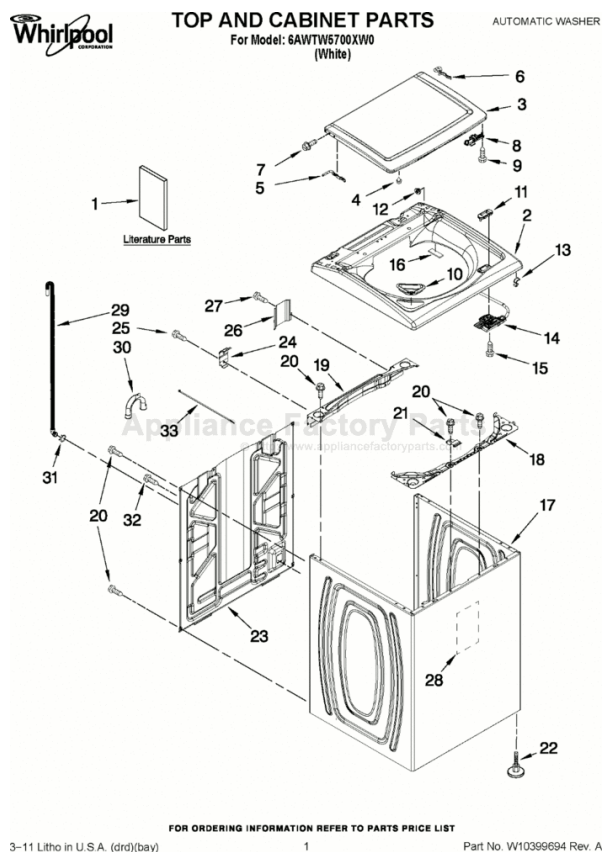

# WHIRLPOOL 6AWTW5700XW0 Owner's Manual

[Shop genuine replacement parts for WHIRLPOOL  
6AWTW5700XW0](#)



[Find Your WHIRLPOOL Washer Parts - Select From 4132 Models](#)

----- Manual continues below -----

# 220–240V 50 Hz WASHER INSTALLATION INSTRUCTIONS

## Table of Contents

WASHER SAFETY .....	2
WASHER DISPOSAL.....	2
INSTALLATION REQUIREMENTS.....	3
Tools and Parts.....	3
Location Requirements .....	3
Drain System .....	4
Electrical Requirements .....	5
INSTALLATION INSTRUCTIONS.....	5
Before you start: remove shipping materials .....	5
Connect Drain Hose.....	6
Connect Inlet Hoses.....	7
Level Washer .....	8
Complete Installation Checklist.....	9

---

### INSTALLATION NOTES

Date of purchase: \_\_\_\_\_

Date of installation: \_\_\_\_\_

Installer: \_\_\_\_\_

Model number: \_\_\_\_\_

Serial number: \_\_\_\_\_

---

## WASHER SAFETY

### Your safety and the safety of others are very important.

We have provided many important safety messages in this manual and on your appliance. Always read and obey all safety messages.



This is the safety alert symbol.

This symbol alerts you to potential hazards that can kill or hurt you and others.

All safety messages will follow the safety alert symbol and either the word "DANGER" or "WARNING."

These words mean:

**! DANGER**

You can be killed or seriously injured if you don't immediately follow instructions.

**! WARNING**

You can be killed or seriously injured if you don't follow instructions.

All safety messages will tell you what the potential hazard is, tell you how to reduce the chance of injury, and tell you what can happen if the instructions are not followed.

## WASHER DISPOSAL



This appliance is marked according to the European directive 2002/ 96/ EC on Waste Electrical and Electronic Equipment (WEEE).

By ensuring this product is disposed of correctly, you will help avoid potential negative consequences for the environment and human health, which could otherwise be caused by inappropriate waste handling of this product.

The symbol on the product, or on the documents accompanying the product, indicates that this appliance may not be treated as household waste. Instead it shall be handed over to the applicable collection point for the recycling of electrical and electronic equipment.

Disposal must be carried out in accordance with local environmental regulations for waste disposal.

For more detailed information about treatment, recovery and recycling of this product, please contact your local city office, your household waste disposal service or the shop where you purchased the product.

# INSTALLATION REQUIREMENTS

## Tools and Parts

Gather required tools and parts before starting installation.

### Tools needed:

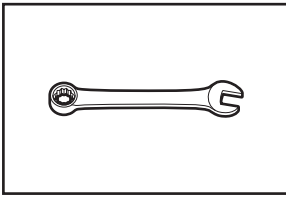

Adjustable or open-end wrench 14 mm (9/16")

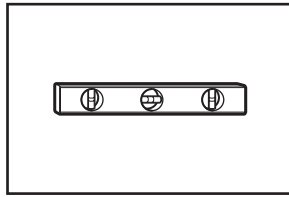

Level

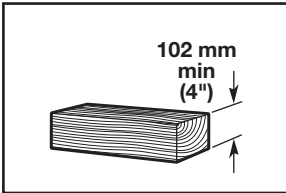

Wood block

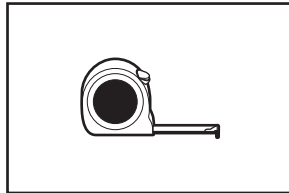

Ruler or measuring tape

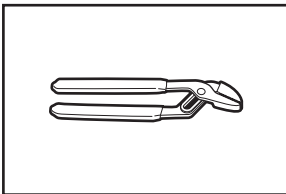

Pliers that open to 39.5 mm (1 9/16")

### Optional tools:

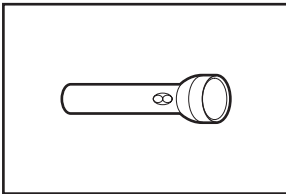

Flashlight

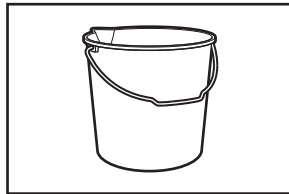

Bucket

### Parts supplied:

**NOTE:** All parts supplied for installation are in cardboard insert in the top of the washer.

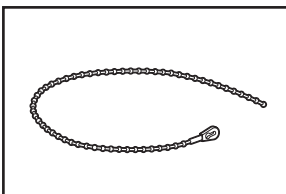

Beaded tie strap

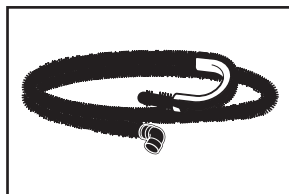

Drain hose with clamp

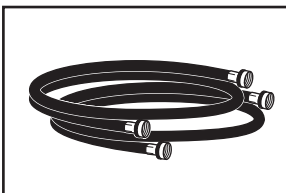

Water inlet hose (2)

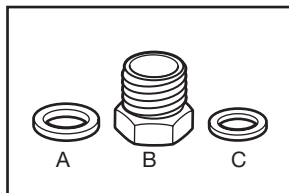

A Large flat washer (4)  
B Inlet hose adapter (2)  
C Small flat washer (2)

Your installation may require additional parts. For information on ordering, contact your dealer.

- 8212656RP 3.0 m (10 ft.) Inlet hose, Black EPDM (2 pack)
- 8212641RP 1.5 m (5 ft.) Inlet hose, Black EPDM (2 pack)
- 8212646RP 1.2 m (4 ft.) Inlet hose, Black EPDM (2 pack)
- 8212545RP 1.5 m (5 ft.) Inlet hose, Red and Blue EPDM (2 pack)
- 8212487RP 1.5 m (5 ft.) Nylon braided inlet hose (2 pack)
- 8212638RP 1.8 m (6 ft.) Nylon braided inlet hose, space saving 90° elbow, hydro-blue steel couplings (2 pack)
- 8212637RP 1.8 m (6 ft.) Inlet hose, Black EPDM, space saving 90° elbow, hydro-blue steel couplings (2 pack)

### Alternate parts: (Not supplied with washer)

Your installation may require additional parts. For information on ordering, contact your dealer.

### If you have:

### You will need:

- |                      |  |
|----------------------|--|
| Overhead sewer       | Standard 76 L (20 gal.) 990 mm (39") tall drain tub or utility sink, sump pump, and connectors (available from local plumbing suppliers) |
| 25 mm (1") standpipe | 51 mm (2") diameter to 25 mm (1") diameter Standpipe Adapter Part Number 3363920<br>Connector Kit Part Number 285835                     |
| Drain hose too short | Extension Drain Hose Part Number 285863<br>Connector Kit Part Number 285835  |
| Lint clogged drain   | Drain Protector Part Number 367031<br>Connector Kit Part Number 285835   |

### Technical Specifications

220-240 V	Clothes Capacity
~50 Hz. AC	6AWTW5550: 8.0 Kg Max.
IP24	6AWTW5700: 8.0 Kg Max.

## LOCATION REQUIREMENTS

Select proper location for your washer to improve performance and minimize noise and possible "washer walk." Install your washer in a basement, laundry room, closet, or recessed area.

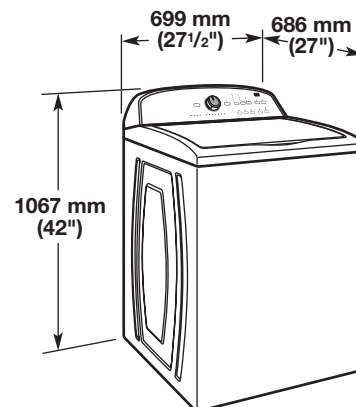

## You will need:

- A water heater set to 60° C (140° F).
- An earthed electrical outlet located within 1.2 m (4 ft) of power cord on back of washer.
- Hot and cold water faucets located within 0.9 m (3 ft) of hot and cold water fill valves on washer, and water pressure of 138–690 kPa (20–100 psi).
- A level floor with maximum slope of 25 mm (1") under entire washer. Installing on carpet is not recommended.
- Floor must support washer's total weight (with water and load) of 143 kgs (315 lbs).

**IMPORTANT:** Do not install, store, or operate washer where it will be exposed to weather or in temperatures below 0° C (32° F). Water remaining in washer after use may cause damage in low temperatures. See "Washer Care" in your "Use and Care Guide" for winterizing information.

Proper installation is your responsibility.

## Recessed area or closet installation

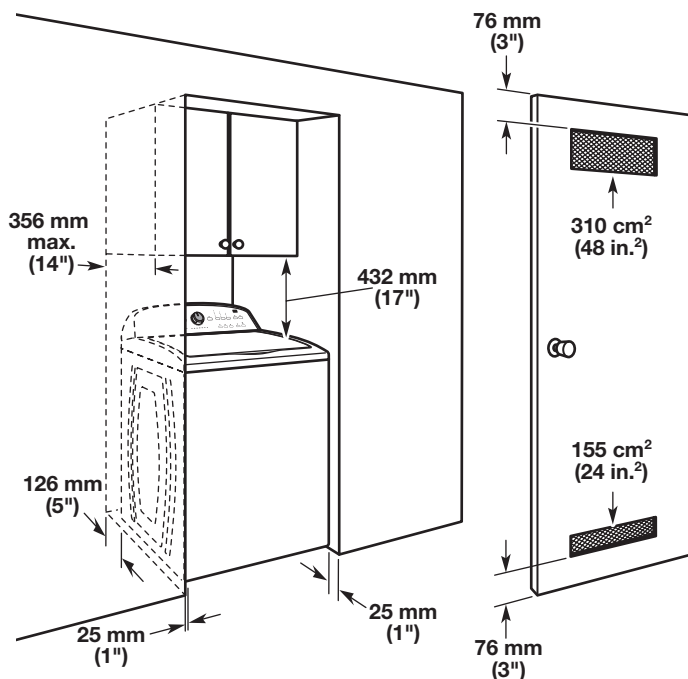

Dimensions show recommended spacing allowed, except for closet door ventilation openings which are minimum required. This washer has been tested for installation with spacing of 0 mm (0") clearance on the sides. Consider allowing more space for ease of installation and servicing, and spacing for companion appliances and clearances for walls, doors, and floor moldings. Add spacing of 25 mm (1") on all sides of washer to reduce noise transfer. If a closet door or louvered door is installed, top and bottom air openings in door are required.

## DRAIN SYSTEM

Drain system can be installed using a floor drain, wall standpipe, floor standpipe, or laundry tub. Select method you need.

### Floor standpipe drain system

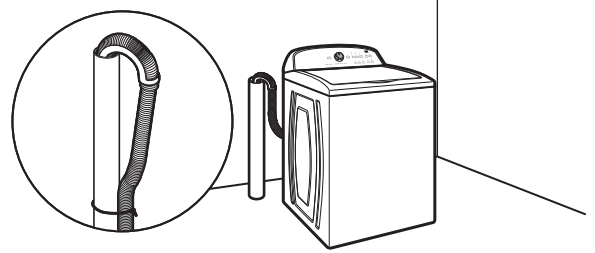

Minimum diameter for a standpipe drain: 51 mm (2"). Minimum carry-away capacity: 64 L (17 gal.) per minute. Top of standpipe must be at least 990 mm (39") high; install no higher than 2.44 m (96") from bottom of washer. If you must install higher than 2.44 m (96"), you will need a sump pump system.

### Wall standpipe drain system

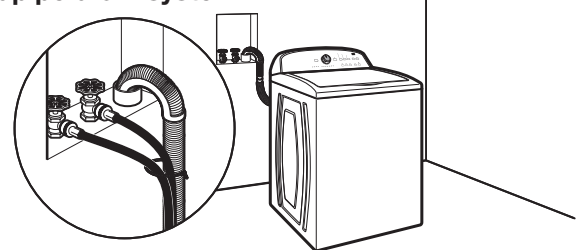

See requirements for floor standpipe drain system.

### Floor drain system

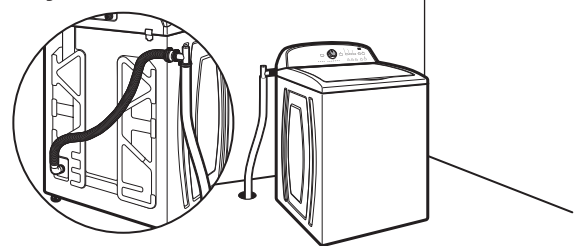

Floor drain system requires a Siphon Break Kit (Part Number 285834), 2 Connector Kits (Part Number 285385), and an Extension Drain Hose (Part Number 285863) that may be purchased separately. To order, contact your dealer. Minimum siphon break: 710 mm (28") from bottom of washer. (Additional hoses may be needed.)

### Laundry tub drain system

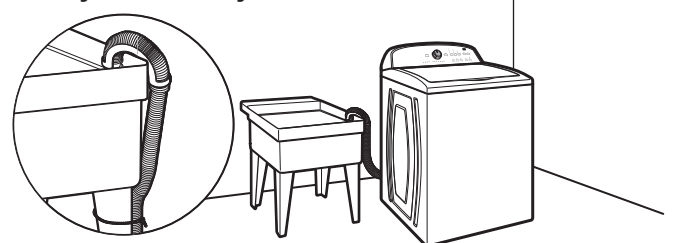

Minimum capacity: 76 L (20 gal.). Top of laundry tub must be at least 990 mm (39") above floor; install no higher than 2.44 m (96") from bottom of washer.

**IMPORTANT:** To avoid siphoning, no more than 114 mm (4.5") of drain hose should be inside standpipe or below the top of wash tub. Secure drain hose with beaded tie strap.

## ELECTRICAL REQUIREMENTS

### **⚠ WARNING**



#### Electric Shock Hazard

**Electrically earth this appliance.**

**Do not use an extension cord or an electrical portable outlet device.**

**Failure to follow these instructions can result in death, fire, or electric shock.**

- A 230 volt, 50 Hz., AC only, 10-amp, fused electrical supply is required. A time-delay fuse or circuit breaker is recommended. It is recommended that a separate circuit breaker serving only this appliance be provided.
- This washer is equipped with a power supply cord having an earthing plug. The plug should be accessible for disconnection from the supply.
- To minimize possible shock hazard, the cord must be plugged into a mating, earthing-type outlet, earthed in accordance with local codes and ordinances. If a mating outlet is not available, it is the personal responsibility and obligation of the customer to have the properly earthed outlet installed by a qualified electrician.
- If codes permit and a separate earth wire is used, it is recommended that a qualified electrician determine that the earth path is adequate.
- Do not earth to a gas pipe.
- Check with a qualified electrician if you are not sure the washer is properly earthed.
- Do not have a fuse in the neutral or earth circuit.
- When in the installed position the mains plug must be accessible for disconnection.

**NOTE:** In accordance with the European EMC Directive (2004/108/EC), the maximum electricity supply system impedance to which the electric washer should be connected is declared to be  $0.231 + j0.144$  ohms.

### EARTHING INSTRUCTIONS

This washer must be earthed. In the event of a malfunction or breakdown, earthing will reduce the risk of electric shock by providing a path of least resistance for electric current. This washer is equipped with a cord having an equipment-earthing conductor and an earthing plug. The plug must be plugged into an appropriate outlet that is properly installed and earthed in accordance with all local codes and ordinances.

**WARNING:** Improper connection of the equipment-earthing conductor can result in a risk of electric shock. Check with a qualified electrician or serviceman if you are in doubt as to whether the appliance is properly earthed.

Do not modify the plug provided with the appliance – if it will not fit the outlet, have a proper outlet installed by a qualified electrician.

## INSTALLATION INSTRUCTIONS

### **⚠ WARNING**

#### Excessive Weight Hazard

**Use two or more people to move and install washer.**

**Failure to do so can result in back or other injury.**

#### Before you start: remove shipping materials

It is necessary to remove all shipping materials for proper operation and to avoid excessive noise from washer.

### 1. Move washer

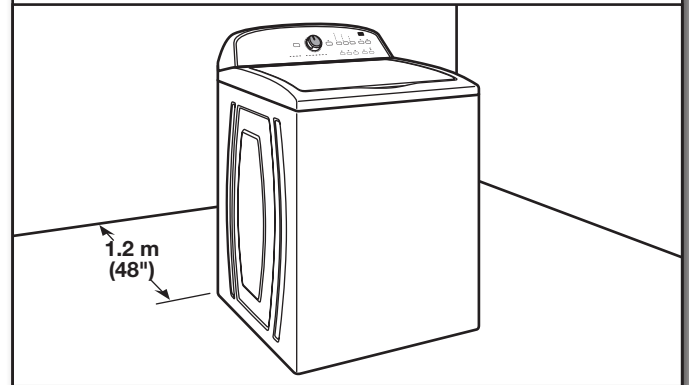

Move washer to within 1.2 m (4 ft) of its final location; it must be in a fully upright position.

**NOTE:** To avoid floor damage, set washer onto cardboard before moving it and make sure lid is taped shut.

### 2. Remove shipping base

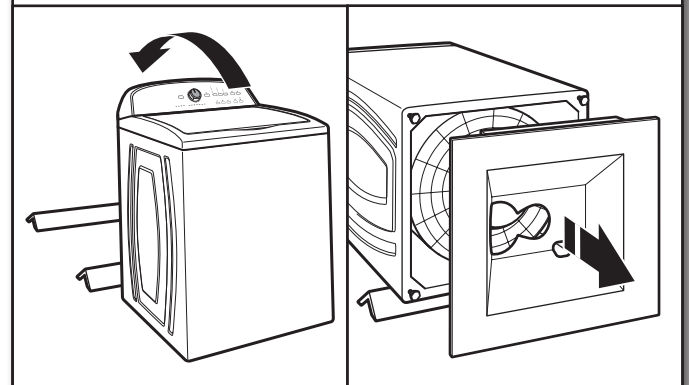

To avoid damaging floor, place cardboard supports from shipping carton on floor behind washer. Tip washer back and place on cardboard supports. Remove shipping base. Set washer upright.

**IMPORTANT:** Removing shipping base is necessary for proper operation. If your washer includes a sound shield, please refer to the instructions included with the sound shield to install it at this time.

### 3. Remove packing tray from tub

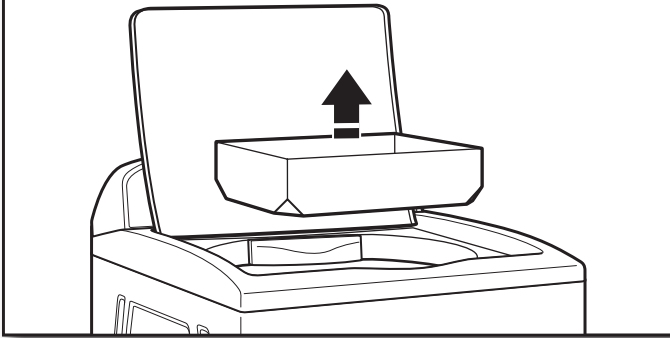

Remove tape from washer lid, open lid and remove cardboard packing tray from tub. Be sure to remove all parts from tray.

**NOTE:** Keep tray in case you need to move washer later.

### 4. Free power cord

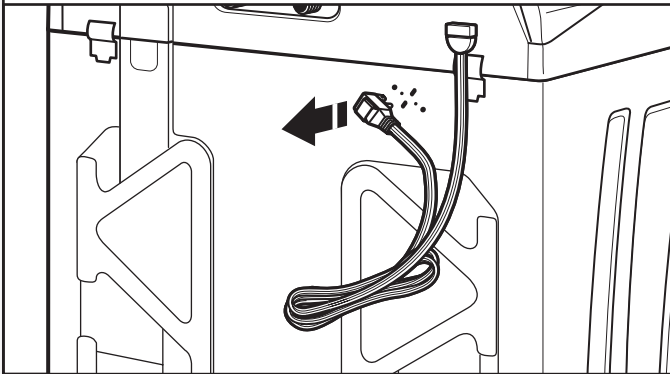

Firmly grasp power cord plug and pull to free from rear panel. Gently place power cord over console to allow free access to back of washer.

## CONNECT DRAIN HOSE

### 5. Attach drain hose to drain port

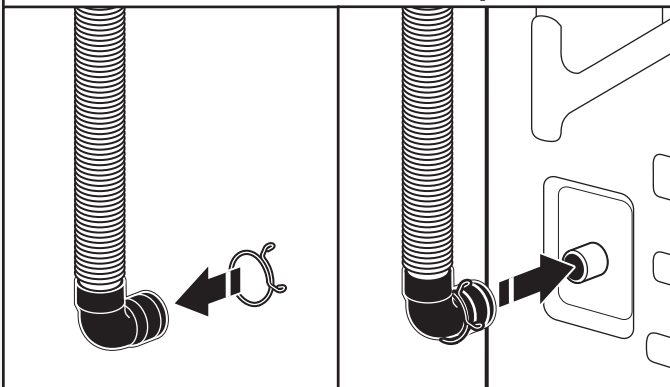

If clamp is not already in place on elbow end of drain hose, slide it over end as shown. Squeeze clamp with pliers and slide black elbow end of drain hose onto black drain port and secure with clamp.

For a laundry tub or standpipe drain, go to step 6.

For a floor drain, remove the preinstalled drain hose form as shown in Step 7. You may need additional parts with separate directions. See "Tools and Parts."

### 6. Place drain hose in standpipe

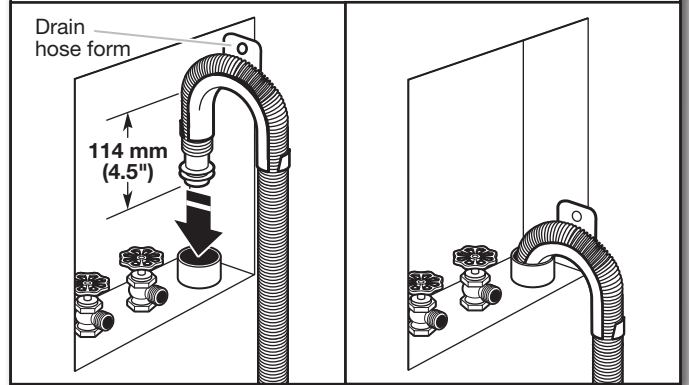

Place hose into standpipe (shown in picture) or over side of laundry tub.

**IMPORTANT:** 114 mm (4.5") of drain hose should be inside standpipe; do not force excess hose into standpipe or lay on bottom of laundry tub. Drain hose form must be used.

### 7. Remove drain hose form (floor drain installations only)

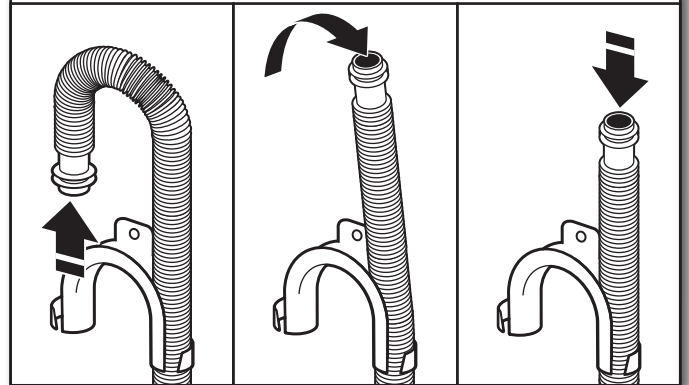

For floor drain installations, you will need to remove the drain hose form from the end of the drain hose. You may need additional parts with separate directions. See "Tools and Parts."

## CONNECT INLET HOSES

The new inlet hoses supplied with this washer must be used. Do not re-use old inlet hoses.

**NOTE:** Both hoses must be attached and have water flowing to inlet valves. If you are only connecting to a cold water tap, you must use a Y-adaptor (not provided).

### 8. Connect hose adapter

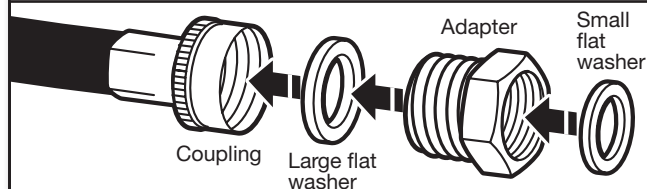

Insert one new large flat washer into one end of each inlet hose. Firmly seat the washers in the couplings. Screw on the hose adapter by hand until it is seated on the washer. Using pliers, tighten the hose adapter with an additional two-thirds turn. **NOTE:** Do not overtighten.

Insert one new small flat washer into the end of the hose adapter. Firmly seat the washers in the couplings.

### 9. Connect inlet hoses to water taps

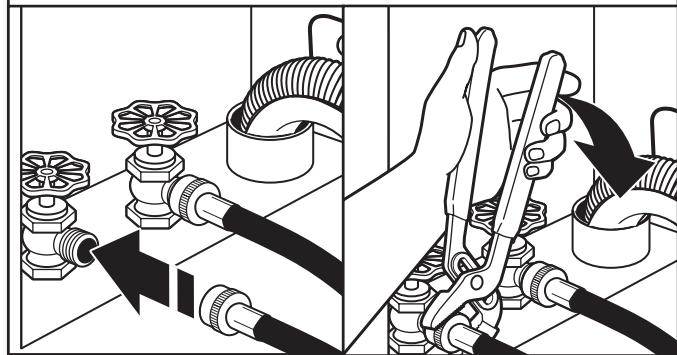

Attach the end of the hose with the adapter, labeled hot, to the hot water tap. Screw on coupling by hand until it is snug on washer. Use pliers to tighten couplings an additional two-thirds turn. Repeat this step with second hose for cold water tap.

**IMPORTANT:** Do not overtighten or use tape or sealants on valve when attaching to taps or washer. Damage can result.

**HELPFUL TIP:** Make note of which hose is connected to hot water to help in attaching hoses to washer correctly. In most standard configurations, hoses will cross over each other when attached correctly.

### 10. Clear water lines



Run water for a few seconds through hoses into a laundry tub, drainpipe, or bucket to prevent clogs. Water should run until clear.

### 11. Insert washers into hoses

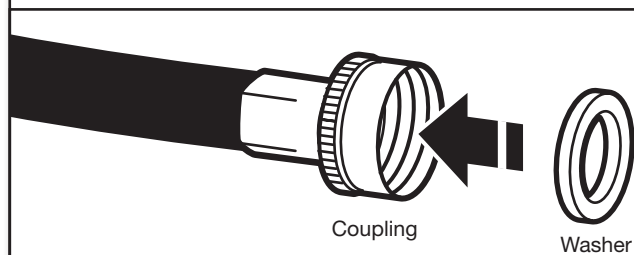

Insert new large flat washers (supplied) into the other ends of the inlet hoses. Firmly seat the washers in the couplings.

### 12. Connect inlet hoses to washer

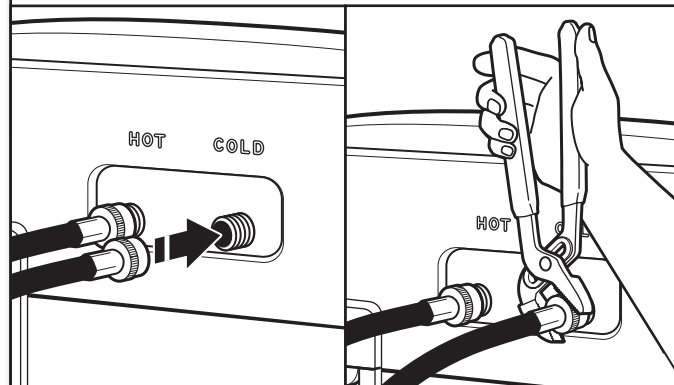

Attach hot water hose to hot water inlet valve marked with a red ring. Screw coupling by hand until it is snug. Use pliers to tighten couplings an additional two-thirds turn. Repeat with cold water inlet valve.

**IMPORTANT:** To reduce risk of hose failure, replace the hoses every 5 years. Record hose installation or replacement dates for future reference.

■ Periodically inspect and replace hoses if bulges, kinks, cuts, wear, or leaks are found.

### 13. Check for leaks

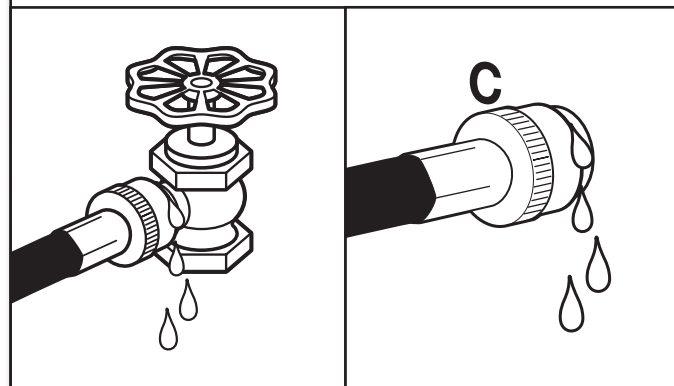

Turn on water taps to check for leaks. A small amount of water may enter washer. It will drain later.

## 14. Secure drain hose

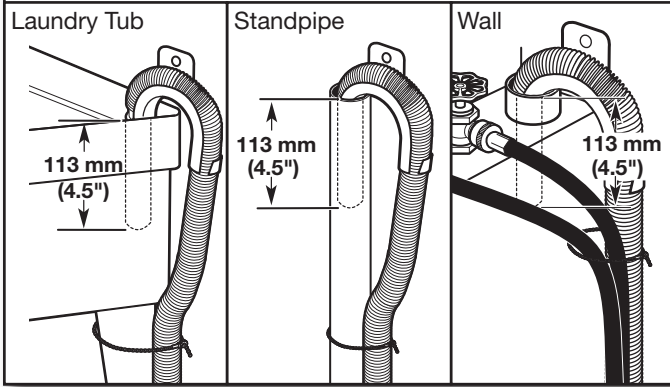

Secure drain hose to laundry tub leg, drain standpipe, or inlet hoses for wall standpipe with beaded tie strap.

## 16. Adjust leveling feet

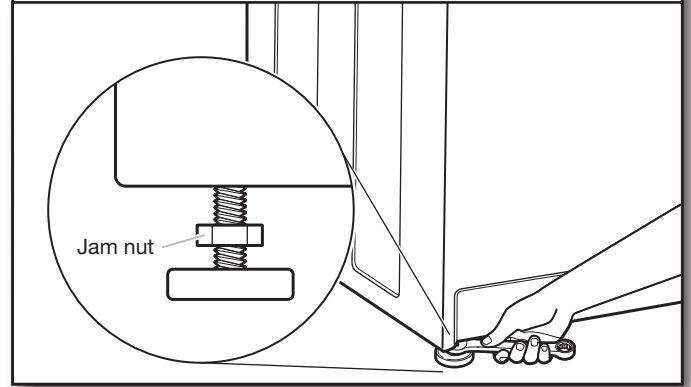

If washer is not level, use a 14 mm or 9/16" open-end or adjustable wrench to turn jam nuts clockwise on feet until they are about 13 mm (1/2") from the washer cabinet. Then turn the leveling foot clockwise to lower the washer or counterclockwise to raise the washer. Recheck levelness of washer and repeat as needed.

**HELPFUL TIP:** You may want to prop up front of washer about 102 mm (4") with a wood block or similar object that will support weight of washer.

## LEVEL WASHER

**IMPORTANT:** Level washer properly to reduce excess noise and vibration.

## 15. Check levelness of washer

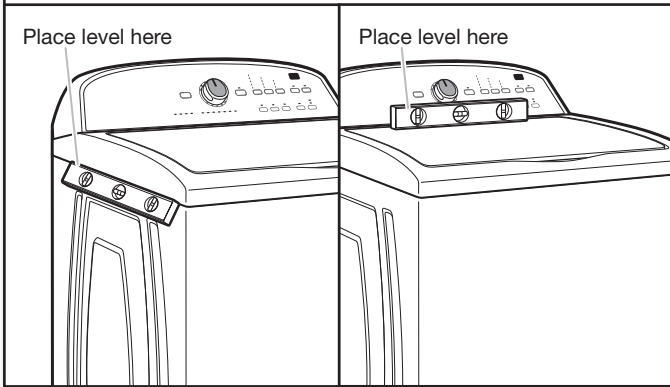

With washer in its final location, place a level on top edges of washer. Use side seam as a guide to check levelness of sides. Check levelness of front using lid, as shown. Rock washer back and forth to make sure all four feet make solid contact with floor. If washer is level, skip to step 16.

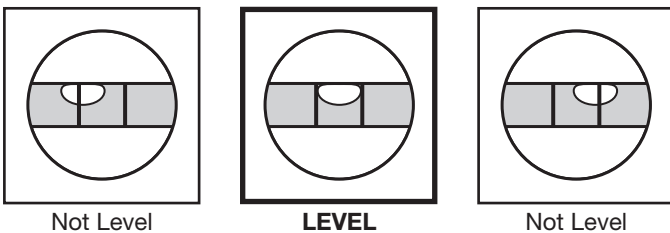

## 17. Tighten leveling feet

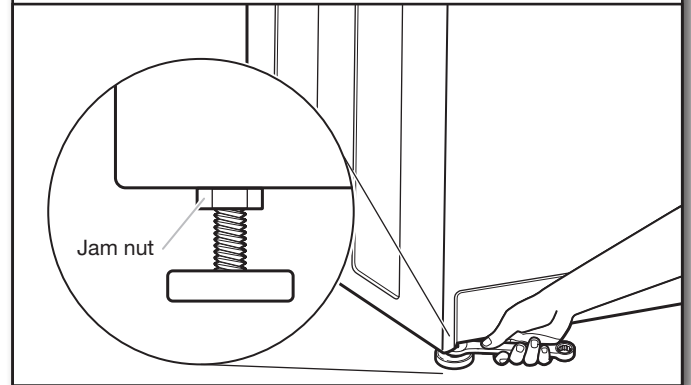

When washer is level, use a 14 mm or 9/16" open-end or adjustable wrench to turn jam nuts counterclockwise on leveling feet tightly against washer cabinet.

**HELPFUL TIP:** You may want to prop washer with wooden block.

## **⚠ WARNING**



### **Electric Shock Hazard**

**Electrically earth this appliance.**

**Do not use an extension cord or an electrical portable outlet device.**

**Failure to follow these instructions can result in death, fire, or electric shock.**

## **18. Plug into an earthed outlet**

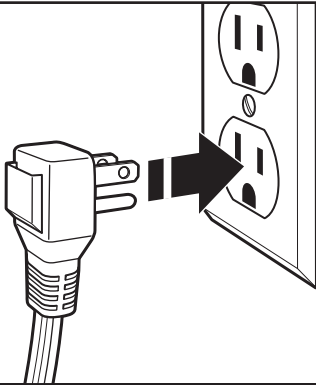

## **COMPLETE INSTALLATION CHECKLIST**

- Check electrical requirements. Be sure you have correct electrical supply and recommended earthing method.
- Check that all parts are now installed. If there is an extra part, go back through steps to see what was skipped.
- Check that you have all of your tools.
- Check that yellow shipping materials were completely removed from back of washer.
- Check that water taps are on.
- Check for leaks around taps and inlet hoses.
- Remove protective film from console and any tape remaining on washer.
- Check that washer is plugged into an earthed 3-prong outlet.
- Dispose of/recycle all packaging materials.
- Read "Washer Use" in your "Washer User Instructions."
- To test and clean your washer, measure 1/2 of normal recommended amount of powdered or liquid detergent and pour it into washer basket or detergent dispenser (on some models). Close lid. Select any cycle. Start washer and allow to complete full cycle.

# NOTES

## NOTES

