

This Owner's Manual is provided and hosted by [Appliance Factory Parts](#).

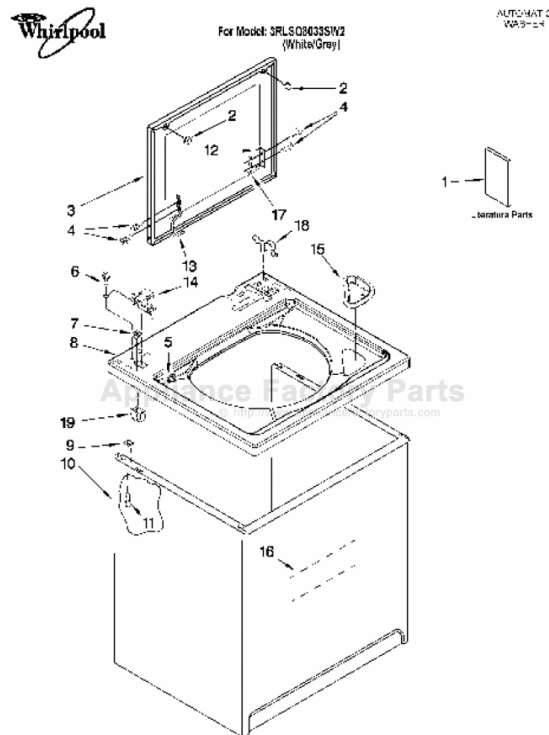

WHIRLPOOL 3RLSQ8033SW2 Owner's Manual

[Shop genuine replacement parts for WHIRLPOOL
3RLSQ8033SW2](#)



[Find Your WHIRLPOOL Washer Parts - Select From 4132 Models](#)

----- Manual continues below -----

American Heavy Duty Laundry Products

Installation and user guide
for use in the U.K.



***Please read this booklet carefully
before installation or use***



W10131548B

*Thank you for buying a Whirlpool American
Heavy duty washer or dryer.*

*We appreciate that this is an important purchase
for you and we want to be sure
that you get the best performance
possible. There are a few differences with
these products when compared with
conventional European models and it
is important that you are aware of them
when preparing for the installation.
Please pay particular attention to the
water pressure requirements and the
type of detergent used.*



Washers

ELECTRICAL CONNECTION:

The power consumption on the washers is very low, an approximate max of 3 amps, and you can connect to a standard 13 amp supply.

WATER CONNECTIONS

Hot and cold fill. You must connect to both hot and cold water supplies. Connection is to a 3/4" BSP (standard UK thread) tap or a stopcock to shut off the water supply, with a minimum water pressure of 15 PSI*. This is no different from a standard washer. It is important that you have a good supply of hot water, as the wash temperature is dependent on the temperature of the incoming water.**

NOTES:

* If either the hot or cold water pressure is low, the fill time will be extended, and some of the advantages of the very short wash cycles will be lost. Because the cycle includes a spray rinse, if the cold water pressure is low, there is no "spray" effect and the rinsing is not as effective.

Operating the washer with low water pressures will result in poor wash and rinse performance.

15 PSI means a water tank needs to be approximately 30 feet above the machine.

** Wash Temperature; if the hot water pressure is very low and the cold water pressure is high, the "mixing" could result in a low wash temperature. Low water pressure is not wide spread, but if it does affect you, it can be overcome by fitting a "booster pump". For more information call 0844 4990101. When prompted by the automated voice response system, select the option for "consumer", then select option #4.

DRAIN CONNECTIONS

This is a large capacity washer and requires a slightly larger drain hose than normal. On standard washers the drain hose is normally placed into a 1-1/2" stand pipe. On the Heavy Duty washer, you will need a 2" stand pipe (or you could place it directly into a suitable sink if preferred).

Dryers

ELECTRICAL CONNECTION

The heater on the electric model is larger than a standard European model, and the total power required to operate the dryer is more than a normal 13 amp socket can provide. It is therefore necessary to connect the power cable directly into a suitable electrical supply that is rated at 30 amps or above, i.e., a spare cooker box.

VENTING

The dryer should be vented to avoid excessive buildup of condensation in the room. The venting outlet on the dryer is a standard 100 mm (4") and does not require any special adapters to connect it to the dryer. Use metal ducting or a flexible metal hose. A standard length metal hose is provided with most models; longer lengths or kits with an elbow are available from Whirlpool Service, telephone: 0870 600 8989, or from most DIY stores or builder merchants.

If in doubt about any of the installation requirements, please contact our technical advice department at 020 8649 5228.

Choosing the correct detergent

To obtain excellent wash results, it is advisable to use a product that is specially designed for top loading washing machines rather than a product that is used in front loading automatic washing machines.

How to get the best results

Sort your clothes according to the garment labels or fabric type. Test articles for colour fastness if they have no wash code. If you mix fabrics, use the programme for the most delicate garment.

Dispensing the detergent

First select the load size, fill temperature, and programme start position – see machine instructions. Pull out the timer knob to start the programme, and let the tub start to fill with water. Open the lid and sprinkle the detergent directly into the water. When the agitator starts, it will quickly disperse the detergent into the water and ensure that it is properly dissolved. Add the laundry by dropping each item into the water while the agitator is working. This will ensure that the laundry is evenly spread around the tub and will give you better wash results. Do not overload the tub. When all the laundry is loaded, close the lid and the machine will complete the wash, rinse, and spin cycles automatically.

Using bleach in your washing machine

There are two different types of bleach that you can use in the washing machine – safe oxygen bleach or hypochlorite (chlorine) bleach (i.e. general household bleach).

If you wish to use bleach, in addition to the detergent, this should be added at the same time as the detergent, once the machine has filled with water.

It is important that you do not add the safe oxygen bleach to the bleach dispenser, or the top of the agitator where the fabric conditioner is poured (refer to the User Manual for further information). If, however, you wish to use a chlorine bleach, you can pre-wash with the bleach (i.e. soak for 10 minutes in a bucket of cold water with half a cup of bleach) and then wash in the machine in the normal way. Or, add the chlorine bleach to the special chlorine bleach dispenser at the top of the machine (refer to the User Manual for further information) and add a detergent that does not contain bleach. It is not advisable to use chlorine bleach with a bleach containing detergent as the interaction between the two will result in poor performance. Do not add chlorine bleach to the top of the agitator where the fabric conditioner is poured (refer to the User Manual for further information).

Linting – reasons and remedies

Today's concerns with saving time, money, and energy often result in washing fewer, but larger, loads that have not been properly sorted. Improper sorting may cause numerous washing problems. One of the more common ones is linting. The following information explains what lint is and how to prevent it.

WHAT IS LINT?

Short fibres and yarns loosened in the laundering process are known as lint. Linting occurs from loose fibres left in garments after manufacture and shedding from fibres wearing off as garments are worn and laundered.



WHAT LINT ISN'T.

PILLING

Pilling is often mistaken for lint. Permanent press fabrics and synthetic fibres have a tendency to pill (form little balls on the surface). Pilling is caused by abrasion from normal wear and use. The areas that are especially noticeable are on collars, cuffs, sleeves . . . areas that are rubbed during use. Because fibres are strong, these balls will not break off during washing or wearing. They give a nubby look to the fabric and will trap lint. Pilling should be brushed off, cut off, or picked off.



REDEPOSITED SOILS

Soil redeposition can also be mistaken for lint. Soil redeposition may look like a grey-white “fuzz” or streak on clothing.

DETERGENT RESIDUE

Some powdered detergents react with the minerals in hard water to form a whitish residue that can also be mistaken for lint. Some powdered detergents may not completely dissolve (especially with cool wash water), which can be mistaken for lint.

How to prevent lint

1. SORT CAREFULLY

Separate “lint givers”, such as chenille, towels, flannel, sweaters, etc., from “lint takers”. Very old and very new items may produce more lint than other items. If loads cannot be sorted properly, expect some lint.

2. USE ENOUGH DETERGENT

Use enough detergent to help hold loose lint in the water until it can be flushed away. Follow the manufacturer’s instructions to determine how much detergent is enough for your washer and clothes load.

3. DON’T OVERLOAD THE WASHER

Overloading causes excess abrasion of fabrics, which increases linting and pilling. Clothes also need to be able to move in the wash and rinse water so loose lint can be carried away. Make sure to select a water level that is correct for the load size being washed.

4. SHORTEN WASHING TIME

Shorten the wash time for smaller load sizes and for lightly soiled loads.

5. USE A DRYER

The tumbling action of a clothes dryer shakes lint loose and allows it to collect in the lint screen. Avoid overdrying to prevent excess buildup of static electricity on synthetic fabrics. Static electricity on fabrics attracts lint.

6. DON’T OVERLOAD THE DRYER

Clothes must tumble freely so loose lint can shake free and be collected in the lint screen.

Suggestions to help reduce linting

- Shake out items to remove excess lint and dirt before laundering.
- Empty pockets to prevent a tissue from shedding lint throughout the wash load. Turn pockets inside-out.
- Turn garments made of “lint-taking” fabrics inside-out before washing.
- Use a fabric softener in the rinse water to reduce the static electricity that causes lint to be attracted to synthetic fibres.
- You may experience a temporary increase in linting if you are washing new or very old fabrics, if you have changed your laundry practices, or if you are using new laundry appliances. The increased linting is the removal from fabrics of surface lint that had not been previously removed. This linting decreases after several washes.

NOTES

NOTES



W10131548B

09/2009