

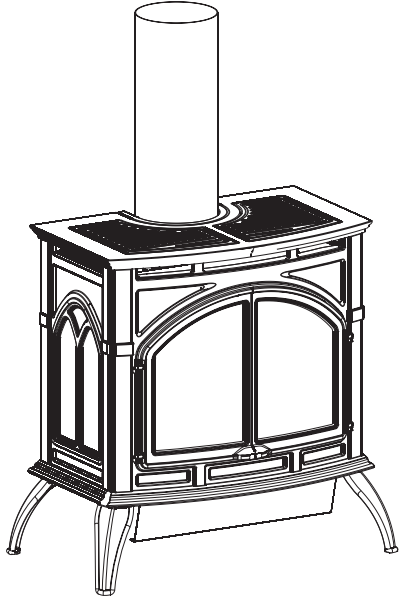

INSTALLATION INSTRUCTIONS AND OWNER'S MANUAL

The Heritage Cast Iron Stoves



CAST IRON DIRECT VENT STOVE

MODELS:

DVP30CA30(B,F,M,S,W)N-2

DVP30CA30(B,F,M,S,W)P-2

GAS-FIRED



Installer: Leave this manual with the appliance.
Consumer: Retain this manual for future reference.

WARNING: If the information in these instructions are not followed exactly, a fire or explosion may result causing property damage, personal injury or loss of life.

- Do not store or use gasoline or other flammable vapors and liquids in the vicinity of this or any other appliance.
- **WHAT TO DO IF YOU SMELL GAS**
 - Do not try to light any appliance.
 - Do not touch any electrical switch; do not use any phone in your building.
 - Immediately call your gas supplier from a neighbor's phone. Follow the gas supplier's instructions.
 - If you cannot reach your gas supplier, call the fire department.
- Installation and service must be performed by a qualified installer, service agency or the gas supplier.



We suggest that our gas hearth products be installed and serviced by professionals who are certified in the U.S. by the National Fireplace Institute® (NFI) as NFI Gas Specialists.

This appliance may be installed in an aftermarket permanently located, manufactured home (USA only) or mobile home, where not prohibited by local codes.

This appliance is only for use with the type of gas indicated on the rating plate. This appliance is not convertible for use with other gases, unless a certified kit is used.

WARNING: Improper installation, adjustment, alteration, service or maintenance can cause injury or property damage. Refer to this manual. For assistance or additional information consult a qualified installer, service agency, or the gas supplier.

TABLE OF CONTENTS

SECTION	PAGE
Important Safety Information	3
Safety Information for Users of LP-Gas	4
Requirements for Massachusetts	5
Introduction	6
Specifications	7
Gas Supply	8
Clearances	9 - 10
Venting Fireplace	11
Restrictor Plate Installation	12
Adjusting Air Shutter	13
Termination Clearances	14
Vent Clearances	15
Vent System Identification	16
Framing and Finishing	17 - 18
Horizontal Termination	18
Vertical Termination	19-20
Log Placement	21
Operating Guidelines	22
Lighting Instructions	23
Pilot Flame Characteristics	24
Main Burner Flame Characteristics	25
Wiring	26 - 27
Maintenance	28
Troubleshooting	29
Firebox Parts List	30
Firebox Parts View	31
Casting Parts List	32
Casting Parts View	33
Accessory Side Shelves	34
Optional Blower Installation Instructions	35 - 36
How To Order Repair Parts	37
Service Notes	37 - 38
Quick Reference	39

IMPORTANT SAFETY INFORMATION

Before enclosing the vent pipe assembly, operate the appliance to ensure it is venting properly.

DO NOT OPERATE THIS APPLIANCE WITHOUT GLASS FRONT PANEL INSTALLED

- This appliance must be installed on a flat, solid, continuous surface (e.g. wood, metal, concrete). This may be the floor, or it may be raised up on a platform to enhance its visual impact. The appliance may be installed on carpeting, tile, wood flooring or other combustible material as the appliance's base extends the width and depth of the appliance.
- Children and adults should be alerted to the hazards of high surface temperatures and should stay away to avoid burns or clothing ignition.
- Young children should be carefully supervised when they are in the same room as the appliance.
- Clothing or other flammable material should not be placed on or near the appliance.
- Adequate accessibility clearances for servicing and proper operation.
- This appliance must not share or be connected to a flue serving a separate solid-fuel burning appliance.
- Keep the area around your appliance clear of combustible materials, gasoline and other flammable vapor and liquids.
- Under no circumstances should any solid fuels (wood, coal, paper or cardboard etc.) be used in this appliance.
- The flow of combustion and ventilation air must not be obstructed in any way.

- Due to high temperatures the appliance should be located out of traffic and away from furniture and draperies.
- The glass front or any part removed for servicing the appliance must be replaced prior to operating the appliance. Work should be done by a qualified service person.
- Keep burner and control compartment clean.
- Vent cap is hot while fireplace is in operation.
- Installation and repair should be done by a **QUALIFIED SERVICE PERSON**. The appliance should be inspected before use and at least annually by a qualified service person. More frequent cleaning may be required due to excessive lint from carpeting, bedding materials, etc. It is imperative that control compartments, burners and circulating air passageways of the appliance be kept clean.
- **DO NOT** put anything around the fireplace that will obstruct the flow of ventilation air.
- Clearance in accordance with local installation codes and the requirements of the gas supplier.
- **DO** keep the appliance area clear and free from combustible material, gasoline and other flammable vapors and liquids.
- **DO** examine venting system periodically and replace damaged parts.
- **DO** make a periodic visual check of pilot and burners. Clean and replace damaged parts.
- **CAUTION:** The glass used in your fireplace is tempered glass. If the glass is cracked or damaged in any way, it should be replaced only with a complete glass frame assembly from Empire. See parts list on Page 30 for ordering.
- **DO NOT** use this fireplace if any part has been under water. Immediately call a qualified service technician to inspect the heater and to replace any part of the control system and any gas control which has been under water.
- Any safety screen or guard removed for servicing an appliance must be replaced prior to operating the appliance.

SAFETY INFORMATION FOR USERS OF LP-GAS

Propane (LP-Gas) is a flammable gas which can cause fires and explosions. In its natural state, propane is odorless and colorless. You may not know all the following safety precautions which can protect both you and your family from an accident. Read them carefully now, then review them point

by point with the members of your household. Someday when there may not be a minute to lose, everyone's safety will depend on knowing exactly what to do. If, after reading the following information, you feel you still need more information, please contact your gas supplier.

LP-GAS WARNING ODOR

If a gas leak happens, you should be able to smell the gas because of the odorant put in the LP-Gas. That's your signal to go into immediate action!

- Do not operate electric switches, light matches, use your phone. Do not do anything that could ignite the gas.
- Get everyone out of the building, vehicle, trailer, or area. Do that IMMEDIATELY.
- Close all gas tank or cylinder supply valves.
- LP-Gas is heavier than air and may settle in low areas such as basements. When you have reason to suspect a gas leak, keep out of basements and other low areas. Stay out until firefighters declare them to be safe.
- Use your neighbor's phone and call a trained LP-Gas service person and the fire department. Even though you may not continue to smell gas, do not turn on the gas again. Do not re-enter the building, vehicle, trailer, or area.
- **Finally**, let the service man and firefighters check for escaped gas. Have them air out the area before you return. Properly trained LP-Gas service people should repair the leak, then check and relight the gas appliance for you.

NO ODOR DETECTED - ODOR FADE

Some people cannot smell well. Some people cannot smell the odor of the chemical put into the gas. You must find out if you can smell the odorant in propane. Smoking can decrease your ability to smell. Being around an odor for a time can affect your sensitivity or ability to detect that odor. Sometimes other odors in the area mask the gas odor. People may not smell the gas odor or their minds are on something else. Thinking about smelling a gas odor can make it easier to smell.

The odorant in LP-gas is colorless, and it can fade under some circumstances. For example, if there is an underground leak, the movement of the gas through soil can filter the odorant. Odorants

in LP-Gas also are subject to oxidation. This fading can occur if there is rust inside the storage tank or in iron gas pipes.

The odorant in escaped gas can adsorb or absorb onto or into walls, masonry and other materials and fabrics in a room. That will take some of the odorant out of the gas, reducing its odor intensity.

LP-Gas may stratify in a closed area, and the odor intensity could vary at different levels. Since it is heavier than air, there may be more odor at lower levels. Always be sensitive to the slightest gas odor. If you detect any odor, treat it as a serious leak. Immediately go into action as instructed earlier.

SOME POINTS TO REMEMBER

- **Learn to recognize the odor of LP-gas.** Your local LP-Gas Dealer can give you a "Scratch and Sniff" pamphlet. Use it to find out what the propane odor smells like. If you suspect that your LP-Gas has a weak or abnormal odor, call your LP-Gas Dealer.
- If you are not qualified, do not light pilot lights, perform service, or make adjustments to appliances on the LP-Gas system. If you are qualified, consciously think about the odor of LP-Gas prior to and while lighting pilot lights or performing service or making adjustments.
- Sometimes a basement or a closed-up house has a musty smell that can cover up the LP-Gas odor. Do not try to light pilot lights, perform service, or make adjustments in an area where the conditions are such that you may not detect the odor if there has been a leak of LP-Gas.
- Odor fade, due to oxidation by rust or adsorption on walls of new cylinders and tanks, is possible. Therefore, people should be particularly alert and careful when new tanks or cylinders are placed in service. Odor fade can occur in new tanks, or reinstalled old tanks, if they are filled and allowed to set too long before refilling. Cylinders and tanks which have been out of service for a time may develop internal rust which will cause odor fade. If such conditions are suspected to exist, a periodic sniff test of the gas is advisable. **If you have any question about the gas odor, call your LP-gas dealer. A periodic sniff test of the LP-gas is a good safety measure under any condition.**
- If, at any time, you do not smell the LP-Gas odorant and you think you should, assume you have a leak. Then take the same immediate action recommended above for the occasion when you do detect the odorized LP-Gas.
- If you experience a complete "gas out," (the container is under no vapor pressure), turn the tank valve off immediately. If the container valve is left on, the container may draw in some air through openings such as pilot light orifices. If this occurs, some new internal rusting could occur. If the valve is left open, then treat the container as a new tank. Always be sure your container is under vapor pressure by turning it off at the container before it goes completely empty or having it refilled before it is completely empty.

REQUIREMENTS FOR MASSACHUSETTS

For all side wall horizontally vented gas fueled equipment installed in every dwelling, building or structure used in whole or in part for residential purposes, including those owned or operated by the Commonwealth and where the side wall exhaust vent termination is less than seven (7) feet above finished grade in the area of the venting, including but not limited to decks and porches, the following requirements shall be satisfied:

1. **INSTALLATION OF CARBON MONOXIDE DETECTORS.** At the time of installation of the side wall horizontal vented gas fueled equipment, the installing plumber or gasfitter shall observe that a hard wired carbon monoxide detector with an alarm and battery back-up is installed on the floor level where the gas equipment is to be installed. In addition, the installing plumber or gasfitter shall observe that a battery operated or hard wired carbon monoxide detector with an alarm is installed on each additional level of the dwelling, building or structure served by the side wall horizontal vented gas fueled equipment. It shall be the responsibility of the property owner to secure the services of qualified licensed professionals for the installation of hard wired carbon monoxide detectors
 - a. In the event that the side wall horizontally vented gas fueled equipment is installed in a crawl space or an attic, the hard wired carbon monoxide detector with alarm and battery back-up may be installed on the next adjacent floor level.
 - b. In the event that the requirements of this subdivision can not be met at the time of completion of installation, the owner shall have a period of thirty (30) days to comply with the above requirements; provided, however, that during said thirty (30) day period, a battery operated carbon monoxide detector with an alarm shall be installed.
2. **APPROVED CARBON MONOXIDE DETECTORS.** Each carbon monoxide detector as required in accordance with the above provisions shall comply with NFPA 720 and be ANSI/UL 2034 listed and IAS certified.
3. **SIGNAGE.** A metal or plastic identification plate shall be permanently mounted to the exterior of the building at a minimum height of eight (8) feet above grade directly in line with the exhaust vent terminal for the horizontally vented gas fueled heating appliance or equipment. The sign shall read, in print size no less than one-half (1/2) inch in size, **“GAS VENT DIRECTLY BELOW. KEEP CLEAR OF ALL OBSTRUCTIONS”**.
4. **INSPECTION.** The state or local gas inspector of the side wall horizontally vented gas fueled equipment shall not approve the installation unless, upon inspection, the inspector observes carbon monoxide detectors and signage installed in accordance with the provisions of 248 CMR 5.08(2)(a) 1 through 4.
 - (b) **EXEMPTIONS:** The following equipment is exempt from 248 CMR 5.08(2)(a)1 through 4:
 1. The equipment listed in Chapter 10 entitled “Equipment Not Required To Be Vented” in the most current edition of NFPA 54 as adopted by the Board; and
 2. Product Approved side wall horizontally vented gas fueled equipment installed in a room or structure separate from the dwelling, building or structure used in whole or in part for residential purposes.
 - (d) **MANUFACTURER REQUIREMENTS - GAS EQUIPMENT VENTING SYSTEM NOT PROVIDED.** When the manufacturer of a Product Approved side wall horizontally vented gas fueled equipment does not provide the parts for venting the flue gases, but identifies “special venting systems”, the following requirements shall be satisfied by the manufacturer:
 1. The referenced “special venting system” instructions shall be included with the appliance or equipment installation instructions; and
 2. The “special venting systems” shall be Product Approved by the Board, and the instructions for that system shall include a parts list and detailed installation instruction.
 - (e) A copy of all installation instructions for all Product Approved side wall horizontally vented gas fueled equipment, all venting instructions, all parts lists for venting instructions, and/or all venting design instructions shall remain with the appliance or equipment at the completion of the installation.

INTRODUCTION

Instructions to Installer

1. Installer must leave instruction manual with owner after installation.
2. Installer must have owner fill out and mail warranty card supplied with the fireplace.
3. Installer should show owner how to start and operate the fireplace.

This direct vent gas fireplace heater is designed to operate with all combustion air being siphoned from the outside of the building and all exhaust gases expelled to the outside of the building. The information contained in this manual pertains to all models and gas control systems unless otherwise noted.

Warning: This unit is not for use with solid fuels.

Notice: During initial firing of this unit, its paint will bake out and smoke will occur. To prevent triggering of smoke alarms, ventilate the room in which the unit is installed.

Notice: Remove screw in valve cover. Screw is required to prevent shipping damage.

Appliance must not be connected to a chimney flue that is servicing a separate solid-fuel burning appliance.

Attention: All vent runs must have a minimum **VERTICAL** rise of two feet. See Venting Fireplace, page 11.

Installation in Residential Garages

Gas utilization equipment in residential garages shall be installed so that all burners and burner ignition devices are located not less than 18" (457 mm) above the floor.

Such equipment shall be located, or protected, so it is not subject to physical damage by a moving vehicle.

Appliance Certification

This fireplace is design certified in accordance with American National Standard/CSA Standard ANSI Z.21-88/CSA 2.33 and by Underwriters Laboratories as a Direct Vent Gas Fireplace Heater and shall be installed according to these instructions.

Consult your local building code agency, prior to installation, to ensure compliance with local codes-including permits and inspections.

The fireplace, when installed with blower, must be electrically grounded in accordance with local codes or, in absence of local codes, with the *National Electric Code ANSI/NFPA 70* or Canadian Electric code, CSA C22.1, if an external electrical source is utilized.

These models may be installed in a bedroom or bed-sitting room in the U.S.A. and Canada.

Qualified Installing Agency

Installation and replacement of gas piping, gas utilization equipment or accessories and repair and servicing of equipment shall be performed only by a qualified agency. The term "qualified agency" means any individual, firm, corporation or company which either in person or through a representative is engaged in and is responsible for (a) the installation or replacement of gas piping or (b) the connection, installation, repair or servicing of equipment, who is experienced in such work, familiar with all precautions required and has complied with all the requirements of the authority having jurisdiction.

State of Massachusetts: The installation must be made by a licensed plumber or gas fitter in the Commonwealth of Massachusetts.

The installation must conform with local codes or, in the absence of local codes, with the *National Fuel Gas Code ANSI Z223.1/NFPA 54* Natural Gas and Propane Installation Code, or CSA B149.1 in Canada.* *Available from the American National Standards Institute, Inc. 11 West 42nd St., New York, N.Y. 10036.

Warning: ANY CHANGE TO THIS FIREPLACE OR ITS CONTROLS CAN BE DANGEROUS.

Improper installation or use of the fireplace can cause serious injury or death from fire, burns, explosions, or carbon monoxide poisoning.

Any alteration of the original design, installed other than as shown in these instructions or use with a type of gas not shown on the rating plate is the responsibility of the person and company making the change.

Important

All correspondence should refer to complete Model Number, Serial Number and type of gas.

High Altitude

When installing this unit at an elevation above 2000 feet (in the United States) it may be necessary to decrease the input rating by changing the existing burner orifice to a smaller size. Generally, input should be reduced 4 percent for each 1000 feet above sea level. However, if the heating value of the gas has been reduced, this general rule may not apply. Check with local gas utility for proper orifice size identification.

Canadian High Altitude

Altitude: 0-4500 feet (0-1370 m)

When installing this unit at an elevation above 4500 feet (in Canada), check with local authorities.

Consult your local gas utility for assistance in determining the proper orifice for location.

Preparation

This direct vent gas fireplace and its components are tested and safe when installed in accordance with this Installation Manual. Report to your dealer any parts damaged in shipment, specifically check glass condition. Do not install unit with damaged, incomplete, or substitute parts. Read all instructions before starting installation and follow these instructions carefully during installation to insure maximum benefit and safety. Failure to follow them will void your warranty and may present a fire hazard.

The warranty will be voided by, and the warranter disclaims any responsibility for the following actions:

- Installation of any damaged fireplace or vent system component.
- Modification of the fireplace or direct vent system.
- Installation other than as instructed by Empire Comfort Systems, Inc.
- Improper positioning of the logs or glass door.
- Installation and/or use of any component part not manufactured or approved by manufacturer.

SPECIFICATIONS

Model			DVP30CA30(B,F,S,M,W)	
			Natural Gas	Propane (LP)
Input BTU/HR (KW/H) Maximum			32,000 (9.3)	30,000 (8.7)
BTU/HR (KW/H) Minimum			22,400 (6.5)	22,000 (6.4)
Height			27 3/4" (705 mm)	27 3/4" (705 mm)
Width			28 1/16" (713 mm)	28 1/16" (713 mm)
Depth			17 3/8" (442 mm)	17 3/8" (442 mm)
Gas Inlet (Pipe)			1/2" (13 mm)	1/2" (13 mm)
Floor to Center of 90° elbow with a 24" length of pipe (See Figure 5)			56 1/4" (1428 mm)	56 1/4" (1428 mm)
Venting Accessories (Special Vent Kits - Simpson DuraVent Can be purchased from Empire Comfort Systems Inc.)				
DVKHP	Direct-Vent Kit for Horizontal Run (46DVA-24B, 46DVA-09B, 46DVA-08AB, 46DVA-DC, 46DVA-WT, 46DVA-HC, 46DVA-E90B)			
DVKVP	Direct-Vent Kit for Vertical Run ((2) 46DVA-48B, 46DVA-DC, 46DVA-F6, 46DVA-SC, 46DVA-FS, 46DVA-VCH)			
Accessories				
TMV	Millivolt Wall Thermostat - Reed Switch			
FRBC	Battery Operated Remote Control			
FRBTC	Battery Operated Remote Control with Thermostat			
FREC	Electric Remote Control			
FWS	Wall Switch			
FRBTP	7-Day Programmable Remote			
TRW	Remote Wall Thermostat			
CIB-3	Automatic Blower			
Stone Inlay Replaces Standard Grill Top				
CSI-8V	Stone Inlay	Venetian Gold		
CSI-9A	Stone Inlay	Adobe Frost		
CSI-10M	Stone Inlay	Patina Mocha		
CSI-11G	Stone Inlay	Temple Gray		
CSI-12A	Stone Inlay	American Beauty		
Cast Iron Stove Side Shelf Kit (Includes Left & Right)				
CSK-B	Side Shelf Kit	Porcelain Black		
CSK-F	Side Shelf Kit	Matte Black		
CSK-M	Side Shelf Kit	Porcelain Mahogany		
CSK-S	Side Shelf Kit	Porcelain Sand		
CSK-W	Side Shelf Kit	Matte Pewter		

GAS SUPPLY

Consult the current National Fuel Gas Code, ANSI Z223.1 CAN/CGA-B149 (.1 or .2) installation code.

Recommended Gas Pipe Diameter

Pipe Length	Schedule 40 Pipe Inside Diameter		Tubing, Type L Outside Diameter	
	Nat.	L.P.	Nat.	L.P.
0-10 feet 0-3 meters	1/2" 12.7 mm	3/8" 9.5 mm	1/2" 12.7 mm	3/8" 9.5 mm
10-40 feet 4-12 meters	1/2" 12.7 mm	1/2" 12.7 mm	5/8" 15.9 mm	1/2" 12.7 mm
40-100 feet 13-30 meters	1/2" 12.7 mm	1/2" 12.7 mm	3/4" 19 mm	1/2" 12.7 mm
100-150 feet 31-46 meters	3/4" 19 mm	1/2" 12.7 mm	7/8" 22.2 mm	3/4" 19 mm

Note: Never use plastic pipe. Check to confirm whether your local codes allow copper tubing or galvanized.

Note: Since some municipalities have additional local codes, it is always best to consult your local authority and installation code.

The use of the following gas connectors is recommended:

- ANS Z21.24 Appliance Connectors of Corrugated Metal Tubing and Fittings
- ANS Z21.45 Assembled Flexible Appliance Connectors of Other Than All-Metal Construction

The above connectors may be used if acceptable by the authority having jurisdiction. The state of Massachusetts requires that a flexible appliance connector cannot exceed three feet in length.

Installing a New Main Gas Cock

Each appliance should have its own manual gas cock.

A manual main gas cock should be located in the vicinity of the unit. Where none exists, or where its size or location is not adequate, contact your local authorized installer for installation or relocation.

Compounds used on threaded joints of gas piping shall be resistant to the action of liquefied petroleum gases. The gas lines must be checked for leaks by the installer. This should be done with a soap solution watching for bubbles on all exposed connections, and if unexposed, a pressure test should be made.

Never use an exposed flame to check for leaks. Appliance must be disconnected from piping at inlet of control valve and pipe capped or plugged for pressure test. Never pressure test with appliance connected; control valve will sustain damage!

NOTE: The gas control is equipped with a captured screw type pressure test point, therefore it is not necessary to provide a 1/8" test point up stream of the control.

A gas valve and ground joint union should be installed in the gas line upstream of the gas control to aid in servicing. It is required by the National Fuel Gas Code that a drip line be installed near the gas inlet. This should consist of a vertical length of pipe tee connected into the gas line that is capped on the bottom in which condensation and foreign particles may collect.

When using copper or flex connector use only approved fittings. **Always provide a union** so that gas line can be easily disconnected for burner servicing.

The appliance and it's individual shut off valve must be disconnected from supply piping system during any pressure testing of that system at test pressures in excess of 1/2 psig (3.5 kPa).

The appliance must be isolated from the gas supply piping system by closing its individual manual shut off valve during any pressure testing of the gas supply piping system at test pressures equal to or less than 1/2 psig (3.5 kPa).

Attention! If one of the procedures results in pressures in excess of 1/2 psig (14" w.c.) (3.5 kPa) on the fireplace gas valve, it will result in a hazardous condition.

Checking Manifold Pressure

Both Propane and Natural gas valves have a built-in pressure regulator in the gas valve. Natural gas models will have a manifold pressure of approximately 3.5" w.c. (.871 kPa) for maximum input or 1.7" w.c. (.423 kPa) for minimum input at the valve outlet with the inlet pressure to the valve from a minimum of 5.0" w.c. (1.245 kPa) for the purpose of input adjustment to a maximum of 10.5" w.c. (2.615 kPa). Propane gas models will have a manifold pressure approximately 10.0" w.c. (2.49 kPa) for maximum input or 5.9" w.c. (1.469 kPa) for minimum input at the valve outlet with the inlet pressure to the valve from a minimum of 11.0" w.c. (2.739 kPa) for the purpose of input adjustment to a maximum of 13.0" w.c. (3.237 kPa).

A 1/8" (3 mm) N.P.T. plugged tapping, accessible for test gauge connection, is located on the outlet side of the gas control.

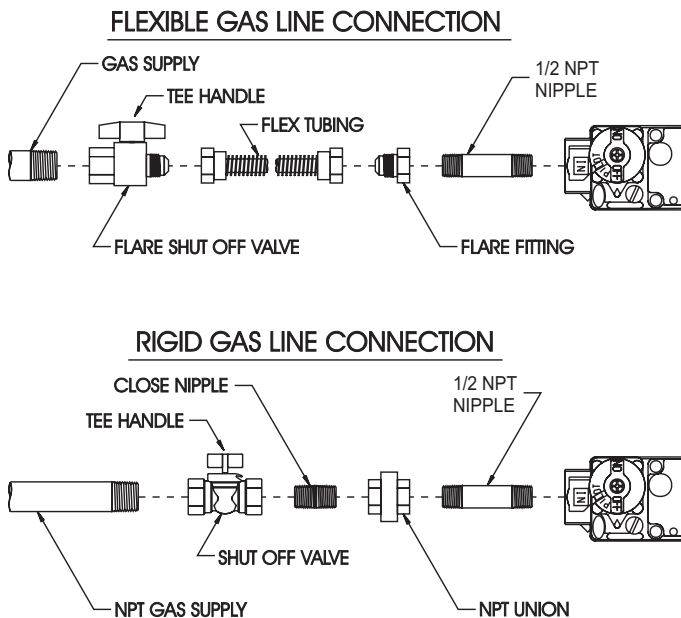

Figure 1

CLEARANCES

In selecting a location for installation, it is necessary to provide adequate accessibility clearances for servicing and proper operation.

Locating and Venting the Direct Vent Fireplace

Clearances: When facing the front of the direct vent fireplace the minimum clearances to combustible construction (material) are the following:

Top of appliance (ceiling)	36" (914.4 mm)
Rear Wall	1" (25.4 mm)
Side Wall	6" (152.4 mm)
Heater Corners (45° angle) to Wall	4" (101.6 mm)
Floor	0" (0 mm)

Installation on Rugs and Tile

This appliance must be installed on a flat, solid, continuous surface (e.g. wood, metal, concrete). This may be the floor, or it may be raised up on a platform to enhance its visual impact. The appliance may be installed on carpeting, vinyl, wood flooring or other combustible material.

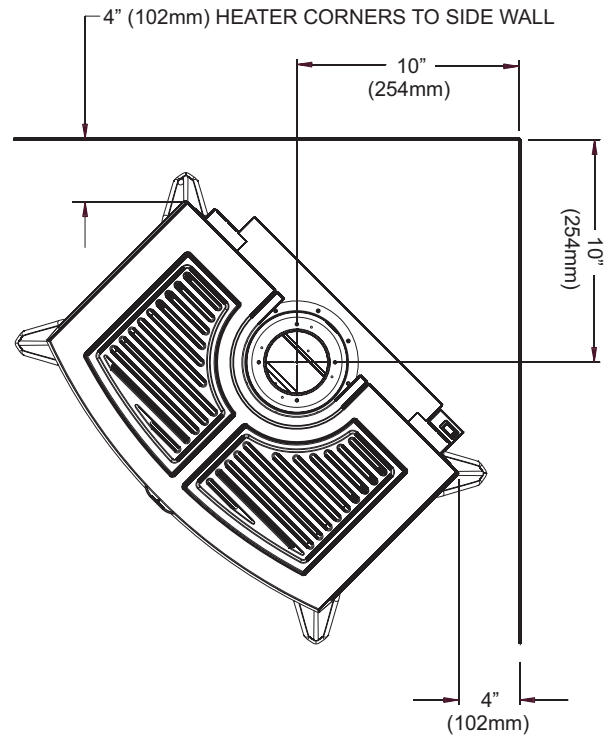

NOTE: HEATER INSTALLED AT 45° ANGLE IN CORNER

Figure 3

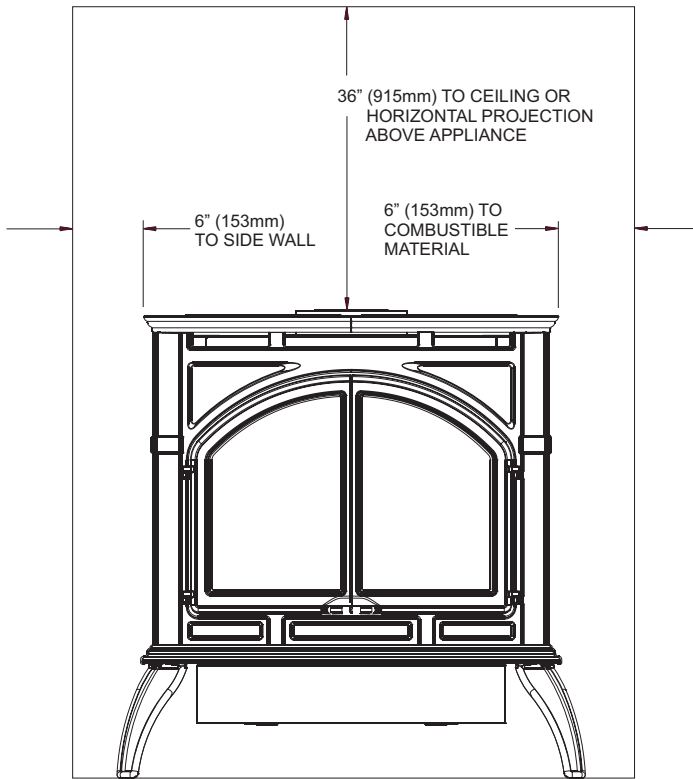

Figure 2

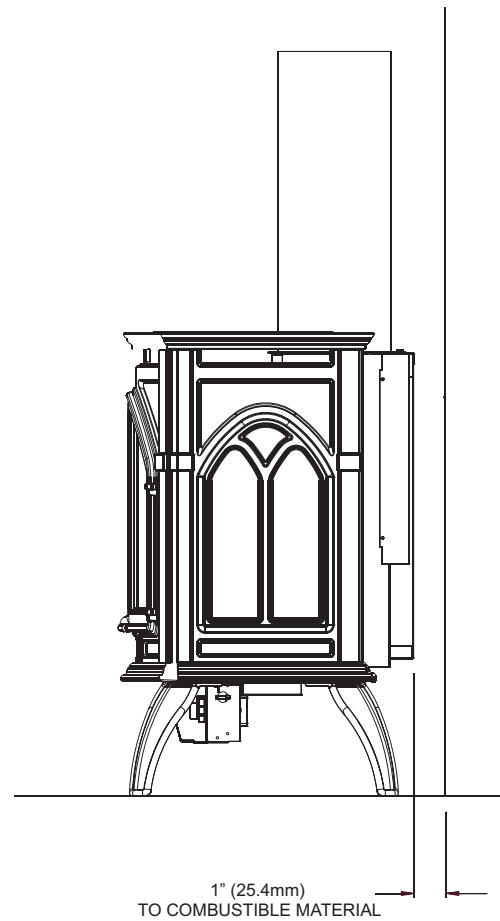

Figure 4

CLEARANCES (cont.)

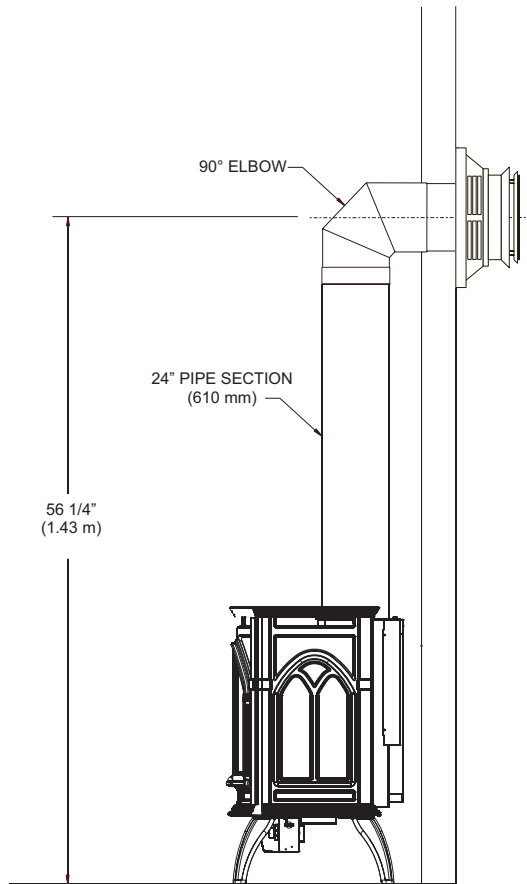

Figure 5

Special Vent Systems

The following vent systems are acceptable for use with the DVP30CA fireplace:

Simpson DuraVent® GS 4" - 6 5/8"

*American Metal® 4" - 6 5/8"

*Selkirk Direct-Temp® 4" - 6 5/8"

* American Metal® and Selkirk Direct-Temp® CAN NOT be used in side wall horizontal vent installations in the state of Massachusetts.

VENTING FIREPLACE

Venting Graph (Dimensions in Feet) (Figure 6)

1. Determine the height of the center of the termination. Using this dimension on the Venting Graph, locate the point it intersects with the slanted graph line, or the right edge of the graph.
2. From the point of this intersection, draw a vertical line to the bottom of the graph.
3. Adjust the indicated maximum dimension for additional elbows if necessary.
4. Position the unit so that maximum horizontal run is not exceeded.

Venting Requirements (Figure 6)

Minimum vertical rise from appliance outlet before any elbows = 24 inches (610 mm).

Maximum vertical rise from appliance outlet = 25 feet (7.62 m), the restrictor plate must be used above 10 feet.

Maximum horizontal run from appliance outlet = 12 feet (3.66 m).

Maximum vertical rise and horizontal run is a combined total of 25 feet (7.62 m).

Maximum elbows = (2) 90°, for the second elbow subtract 5 feet from a horizontal run.

To Use the Vent Graph

EXAMPLE A:

If the vertical rise from the appliance outlet is 21 feet, the horizontal run to the outer wall flange of the vent termination must not exceed 4 feet with (1) 90° elbow.

EXAMPLE B:

If the vertical rise from the appliance outlet is 14 feet, the horizontal run to the outer wall flange of the vent termination must not exceed 11 feet with (1) 90° elbow.

SPECIAL NOTE: For each 45 degree elbow installed in the horizontal run, the length of the horizontal run MUST be reduced by 18 inches (457.2 mm). This does not apply if the 45 degree elbows are installed on the vertical rise of the vent system.

Example: According to the chart the maximum horizontal run is 12 feet and if two 45 degree elbows are required in the horizontal run it must be reduced to 9 feet.

The maximum number of 45 degree elbows permitted per side wall installation is two. These elbows can be installed in either the vertical rise or horizontal run.

VENTING FIREPLACE (cont.)

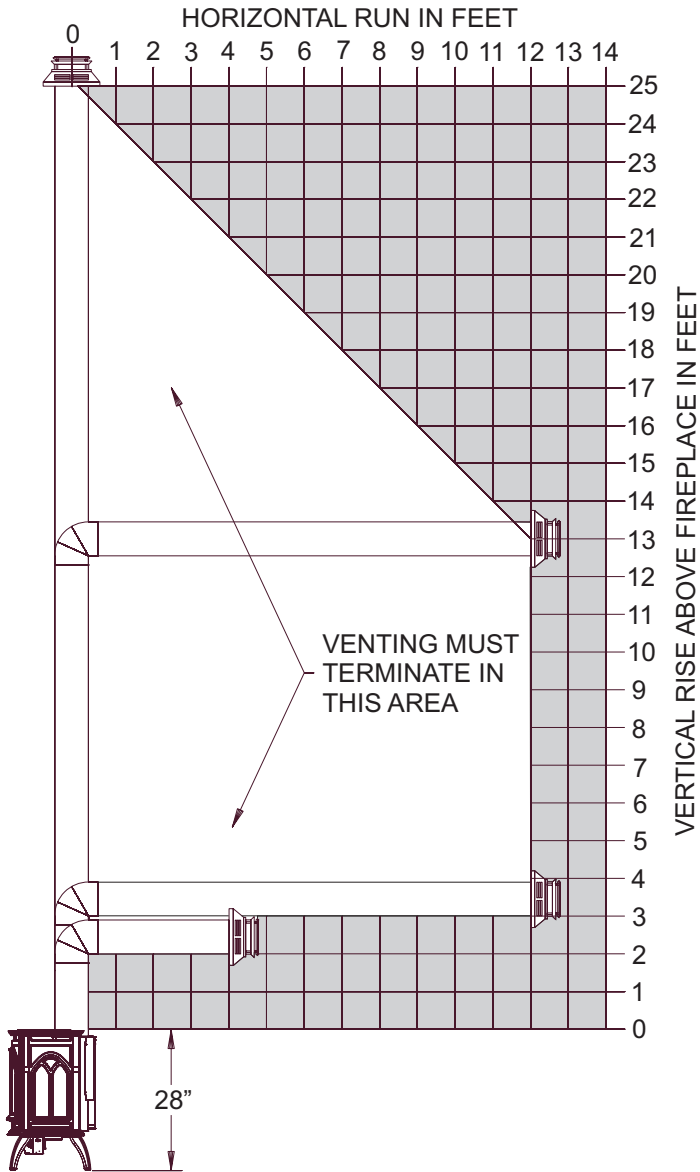

Figure 6

Sidewall Venting

The maximum vertical and horizontal distances are 25 feet and 12 feet, respectively. Vertical dimensions are based on top of fireplace to centerline of pipe. Horizontal dimensions are based on centerline of pipe to termination.

CAUTION: Total vertical run **MUST BE** completed before starting horizontal run. **Horizontal chimney run must slope upward (away from fireplace) 1/4" per foot and vent termination must be level.**

Under no circumstances should combustible materials (including siding) be closer than 2" from the top of the 6 5/8" pipe or closer than 1" on the side and bottom.

Cutting the Hole (Figure 7)

After the appliance has been positioned in its permanent location, the hole through the exterior wall of the house can be cut. This hole needs to be 10" high x 10" wide square with its center line determined by the amount of vertical arise and horizontal run of the termination. When locating the hole it must be noted that the bottom of the cap must be 12" above the ground level, and top of the cap must be no less than 18" below a combustible projection, and no closer than 9" to any wall running parallel to vent termination.

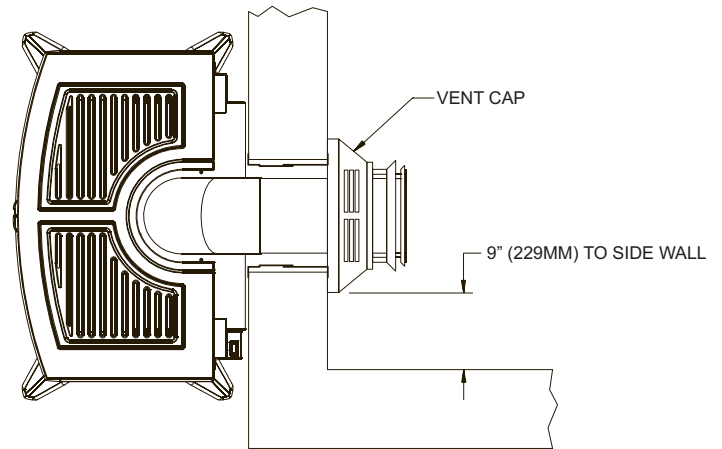

Figure 7

RESTRICTOR PLATE INSTALLATION

The restrictor plate is to be used only in a completely vertical vent installation. The restrictor plate can be used when the vertical vent rise is between 10 feet and 25 feet.

In a vertical vent rise the rear (yellow) flames on the main burner can be reduced due to the drawing action from the flue exhaust pipe and the air inlet pipe. A decrease in the height or the appearance of the yellow flame may occur when the vertical vent rise is between 10 feet and 25 feet. To enhance the yellow flame on the main burner, the restrictor plates need to be installed on both air inlet holes behind the log shelf.

Please use the following steps to install the restrictor plate.

1. Remove cast iron top and carefully set aside.
2. Remove cast iron front and carefully set aside.
3. Carefully remove glass door.
4. Remove the log shelf by removing the (2) screws securing the log shelf to the wall.
5. Loosen the upper (2) screws of both air inlet holes.
6. Slide restrictor plates down over loosened screws. Tighten (4) screws securely.
7. Modify log shelf by bending tab on front edge flat for LP or down for Natural gas.
8. Replace log shelf carefully by replacing the (2) screws.
9. Carefully replace glass door.
10. Replace cast iron front.
11. Replace cast iron top.
12. Installation of restrictor plate is completed.

Attention: Restrictor plates for Natural gas have diamond shaped notches for mounting on screws. LP gas plates have square shaped notches for mounting on screws. Be sure to use the proper restrictor plate for the gas type.

Attention: See Page 30 to order restrictor plate.

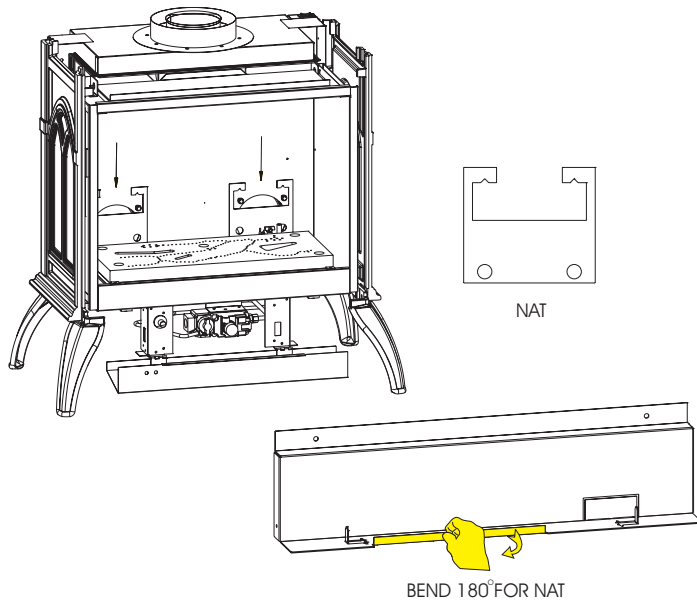

Figure 8

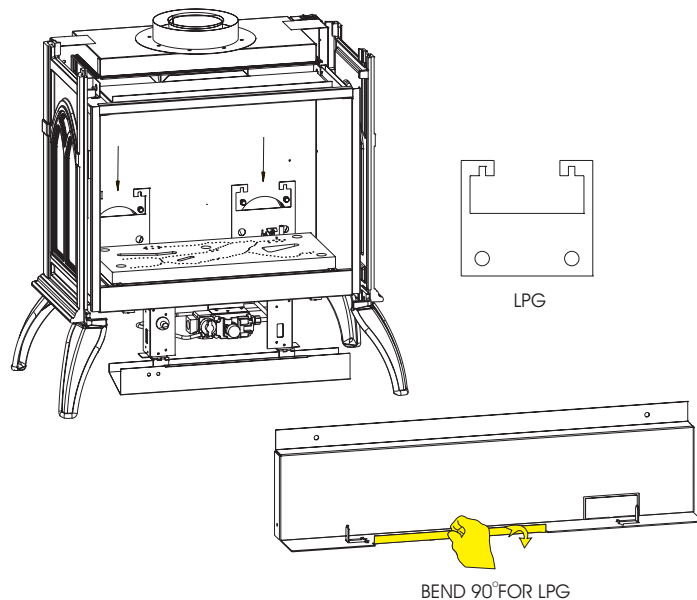

Figure 9

ADJUSTING AIR SHUTTER

The air shutter has been factory set to the optimum performance level for this appliance. LP air shutter is not adjustable.

1. Remove cast iron top and carefully set aside.
2. Remove cast iron front and carefully set aside.
3. Carefully remove glass door. See Figure 10.
4. Carefully remove logs and set aside.
5. Remove the log shelf by removing the (2) screws securing the log shelf to the rear wall. See Figure 11.
6. Remove the burner by removing the (2) screws at the front of the burner as shown in figure 12.
7. Carefully remove the burner by lifting straight up.
8. Loosen the (2) nuts on the air shutter shown in figure 12 to adjust the air shutter. Figure 13 call-out demonstrates the proper locations for NAT gas. LP Air shutter is not adjustable.
9. Tighten the (2) nuts back down locking the air shutter in place. Be sure that the air shutter is the same distance from the burner orifice on both sides of the air shutter for proper burner fit up.
10. Carefully replace the burner by dropping it down over the orifice holder and air shutter lining up the front mounting holes with the holes on the firebox.
11. Replace the (2) screws at the front of the burner shown in figure 12.
12. Replace the log shelf by replacing the (2) screws securing the log shelf to the rear wall. See Figure 11.
13. Replace logs. See page 21.
14. Carefully replace glass door.
15. Replace cast iron front.
16. Replace cast iron top.

Note: Be sure air shutter is adjusted and tightened evenly to ensure proper fit, failure to evenly adjust air shutter can cause improper combustion. Only a certified technician should adjust the air shutter.

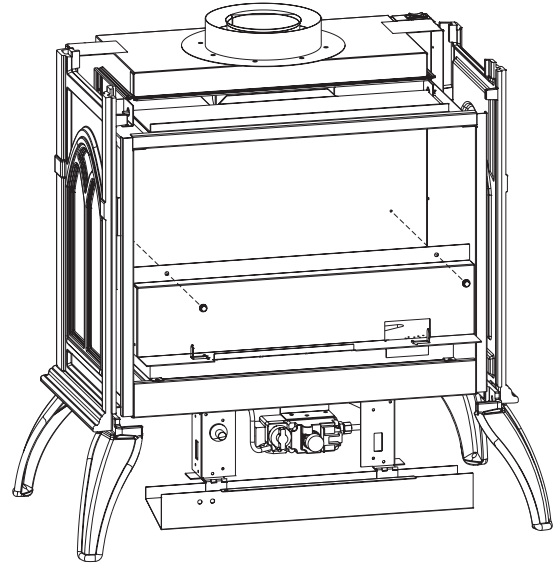

Figure 11

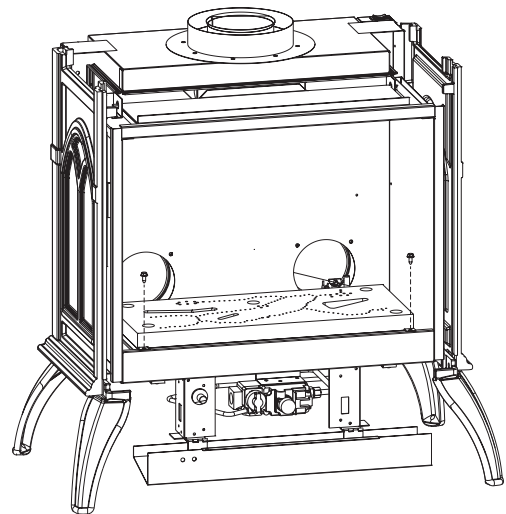

Figure 12

SHOWN WITH TOP & FRONT REMOVED

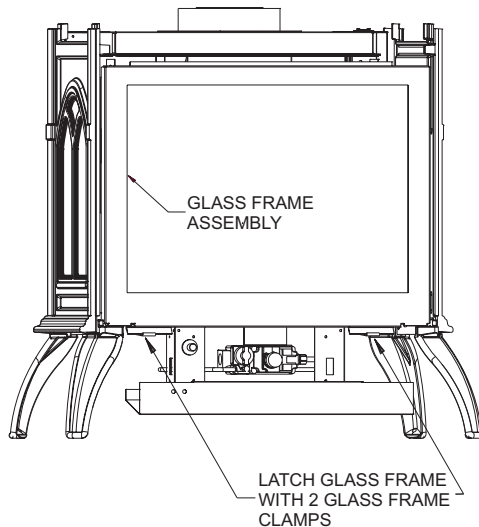

Figure 10

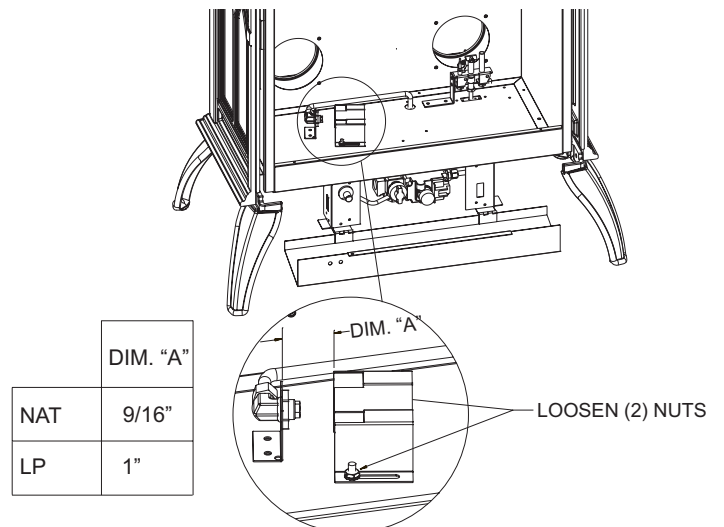

Figure 13

TERMINATION CLEARANCES

Termination clearance for buildings with combustible and noncombustible exteriors.

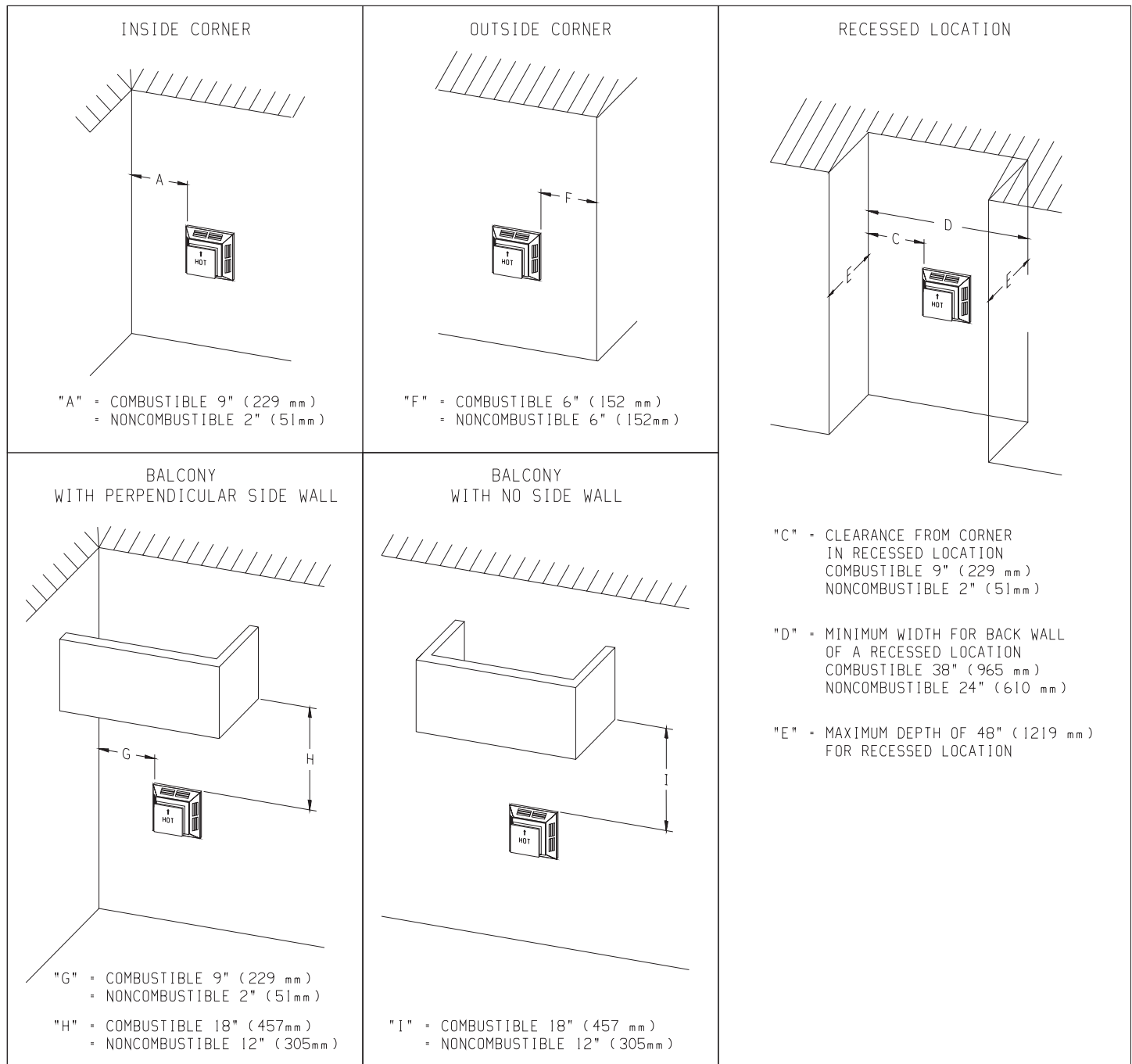

Figure 14

Vertical Sidewall Installations

Important! Minimum clearance between vent pipes and combustible materials is one inch (1") (25 mm) on bottom and sides and (2") (51 mm) on top.

Important! When vent termination exits through foundation less than 20" below siding outcrop, the vent pipe must flush up with the siding. 48-DVA-HC termination cap must also be used.

Information on Various Venting Routes and Components

Important: It is always best to locate the appliance in such a way that minimizes the number of offsets and horizontal vent length.

Since it is very important that the venting system maintain its balance between the combustion air intake and the flue gas exhaust, certain limitations as to vent configurations apply and must be strictly adhered to.

The graph showing the relationship between vertical and horizontal side wall venting will help to determine the various vent lengths allowable.

The horizontal vent run refers to the total length of vent pipe from the vent elbow of the appliance to the face of the outer wall.

VENT CLEARANCES

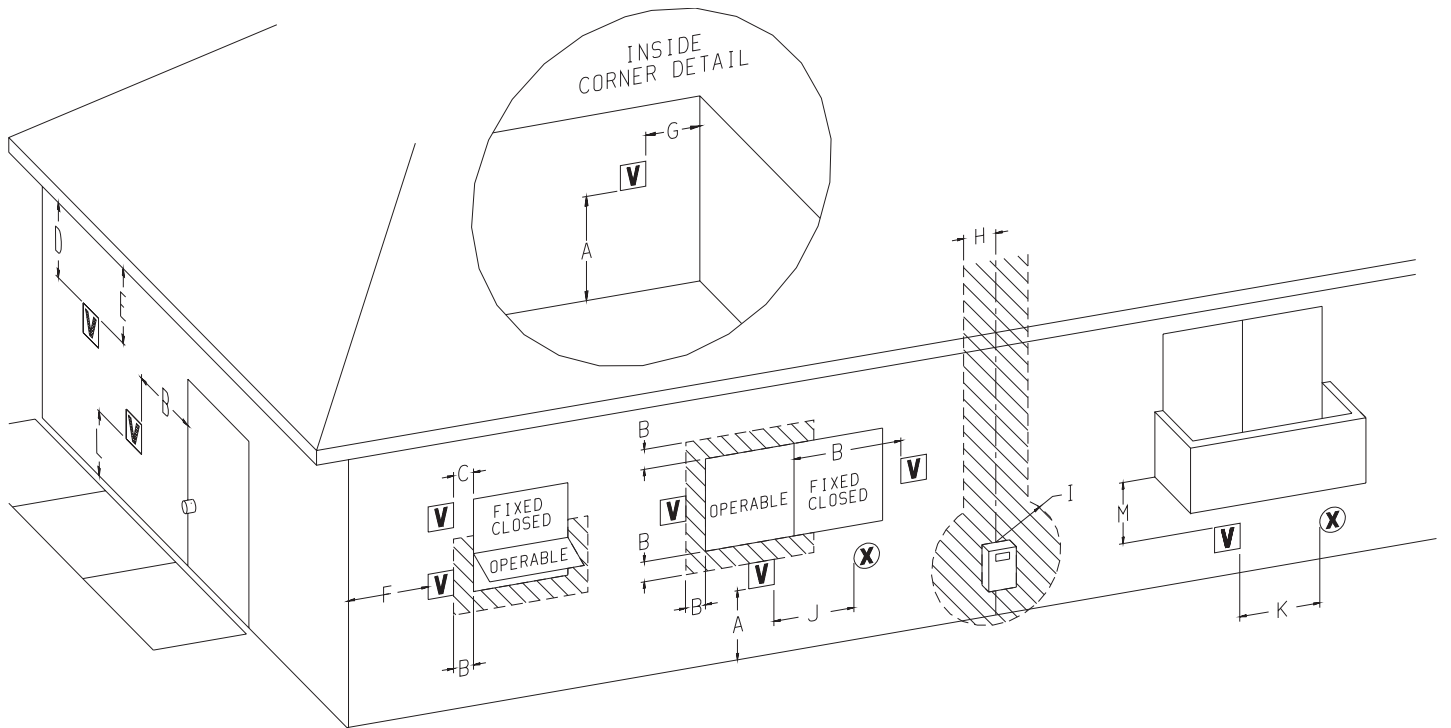

V VENT TERMINAL **X** AIR SUPPLY INLET [Hatched Area] AREA WHERE TERMINAL IS NOT PERMITTED

Figure 15

- A = *Clearance above grade, veranda, porch, deck or balcony [*12 inches (304.8 mm) minimum]
- B = Clearance to window or door that may be opened [*9 inches (228.6 mm) minimum for appliances < 50,000 Btuh (14.6 kW)]
- C = Clearance to permanently closed window [minimum 12 inches (304.8 mm) recommended to prevent condensation on window]
- D = Vertical clearance to ventilated soffit located above the terminal within a horizontal distance of 24 inches (609.6 mm) from the top of the terminal
- E = Clearance to unventilated soffit [24 inches (609.6 mm) minimum]
- F = Clearance to outside corner [12 inches (304.8 mm) minimum]
- G = Clearance to inside corner [9 inches (228.6 mm) minimum]
- H = *Not to be installed above a meter/regulator assembly within 3 feet (914.4 mm) horizontally from the center-line of the regulator
- I = Clearance to service regulator vent outlet [*6 feet (1.83 m) minimum]
- J = Clearance to non-mechanical air supply inlet to building or the combustion air inlet to any other appliance [*12 inches (304.8 mm) minimum for appliances ≤ 100,000 Btuh (30 kW) 36 inches (914.4 mm) minimum for appliances > 100,000 Btuh (30 kW)]
- K = Clearance to a mechanical air supply inlet [* 6 feet (1.83 m) minimum]
- L = †Clearance above paved sidewalk or a paved driveway located on public property [*7 feet (2.13 m) minimum]
- M = Clearance under veranda, porch, deck, or balcony [*12 inches (304.8 mm) minimum]‡
- † A vent shall not terminate directly above a sidewalk or paved driveway which is located between two single family dwellings and serves both dwellings*
- ‡ Only permitted if veranda, porch, deck, or balcony, is fully open on a minimum of 2 sides beneath the floor*
- * As specified in CGA B149 Installations Codes or ANSI Z223.1. Note: Local Codes or Regulations may require different clearances.

VENT SYSTEM IDENTIFICATION

Installing Vent Components (Figure 16 and Figure 17)

Begin the vent system installation by installing the first Simpson Duravent component, a straight pipe on the top of the appliance, or rotate the vent elbow to the horizontal position then add horizontal and vertical pipe lengths and then a horizontal or vertical termination kit. Elbows can be added where necessary. See Pages 14 through 16 for venting requirements.

Simpson Duravent vent system components lock into place by sliding the concentric pipe section with four (4) equally spaced interior beads onto the appliance collar or previously installed component end with four (4) equally spaced indented sections. When the internal beads of each starting 6 5/8 inch outer pipe line up, rotate pipe section clockwise 90° (approximately 3 inches). The vent pipe is now locked together.

Continue adding components per the pre-planned vent system configuration. Be certain that each succeeding vent component is securely fitted and locked into the preceding component in the vent system.

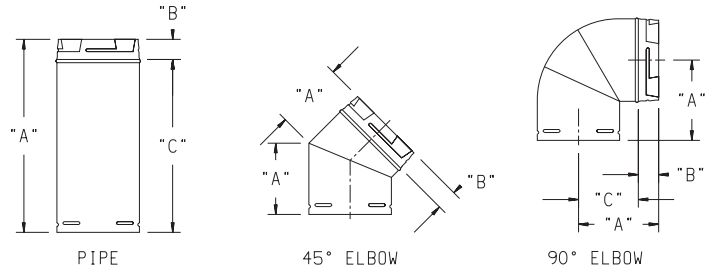

PART NAME	"A"	"B"	"C"
6" PIPE	6" (152 mm)	1 1/2" (38 mm)	4 1/2" (114 mm)
9" PIPE	9" (229 mm)	1 1/2" (38 mm)	7 1/2" (191 mm)
12" PIPE	12" (305 mm)	1 1/2" (38 mm)	10 1/2" (267 mm)
24" PIPE	24" (610 mm)	1 1/2" (38 mm)	22 1/2" (572 mm)
36" PIPE	36" (914 mm)	1 1/2" (38 mm)	34 1/2" (876 mm)
48" PIPE	48" (1.220 m)	1 1/2" (38 mm)	46 1/2" (1.18 m)
45° ELBOW	5 1/2" (140 mm)	1 1/2" (38 mm)	---
90° ELBOW	6 1/2" (165 mm)	1 1/2" (38 mm)	5" (127 mm)

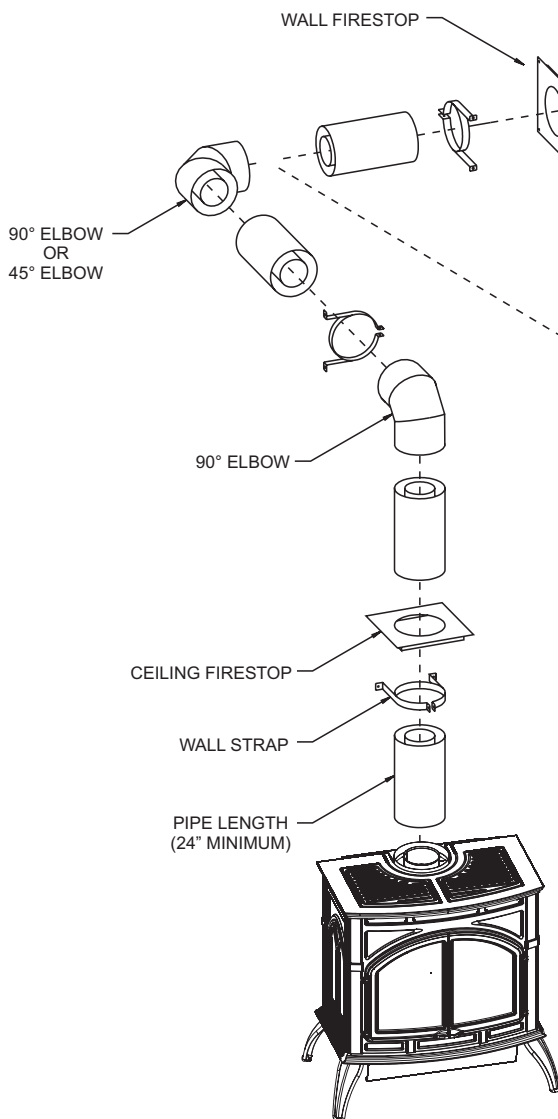
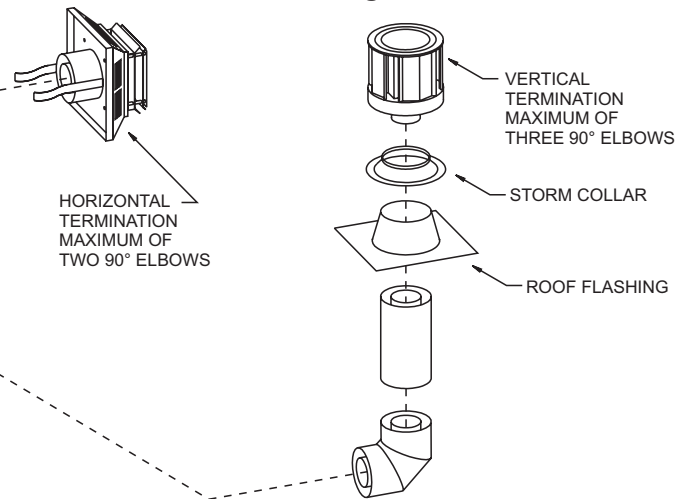

Figure 16

Figure 17



Special Venting Components (Simpson Duravent)

See Empire Comfort Systems Inc. Retail Price List for Simpson Duravent part numbers and pricing.

FRAMING AND FINISHING

Installing Support Brackets (Figure 18)

A horizontal pipe support **MUST BE** used for each 3 feet of horizontal run. The pipe supports should be placed around 6 5/8 inch diameter pipe and nailed in place to framing members. There **MUST BE** a 2 inch clearance to combustibles above 6 5/8 inch diameter pipe and elbows and 1 inch clearance on both sides and bottom of 6-5/8 inch to combustibles on all horizontal pipe sections and elbows.

Vertical runs of this vent systems must be supported every 4 feet above the appliance flue outlet by wall brackets attached to the 6 5/8 inch vent pipe and secured with nails or screws to structural framing members.

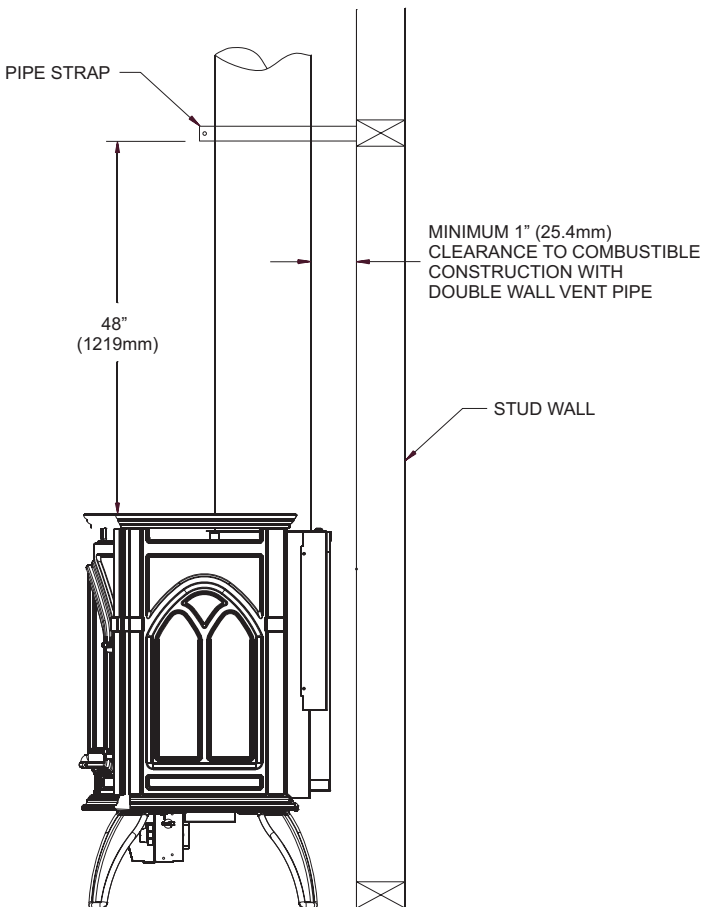

Figure 18

Installing Firestops (Figures 19, 20, 21 and 22)

Firestops are required for safety whenever the vent system passes through an interior wall, an exterior wall, or a ceiling. These firestops act as a firebreak heat shield and as a means to insure that minimum clearances are maintained to the vent system.

Horizontal runs in the vent system which pass through either interior or exterior walls, require the use of wall firestops on both sides of the wall through which the vent passes.

Position the firestops on both sides of the 10 inch x 10 inch hole, previously cut. Secure with nails or screws. Continue the vent run through the firestops. (See Figure 19)

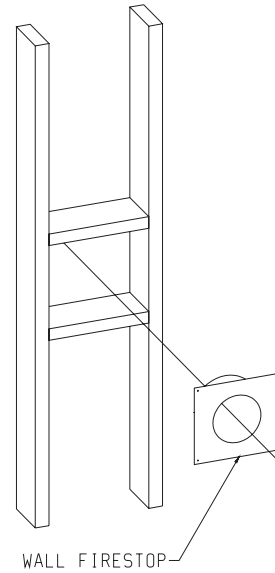

Figure 19

Vertical runs of this system which pass through ceilings require the use of **ONE (1)** ceiling firestop at the hole in each ceiling through which the vent passes.

Position a plumb bob directly over the center of the vertical vent component and mark the ceiling to establish the center point of the vent. Drill a hole or drive a nail through this center point and check the floor above for any obstructions such as wiring or plumbing runs. Reposition the appliance and vent system, if necessary, to accommodate ceiling joists and/or obstructions.

Cut a 10 inch x 10 inch hole through the ceiling, using the center point previously marked. Frame the hole with framing lumber the same size as the ceiling joists. (See Figure 20) If the area above the ceiling is **NOT** an attic, position and secure the ceiling firestop (46DVA-FS) on the ceiling side of the previously cut and framed hole. (See Figure 21) If the area above the ceiling **IS** an attic, position and secure the firestop on top of the previously framed hole. (See Figure 22)

NOTE: Remove insulation from the framed area in the attic before installing the firestop and/or vent stop and/or vent pipes.

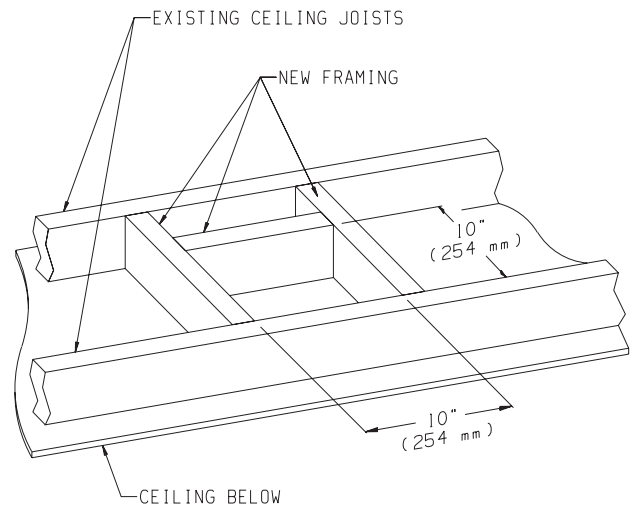

Figure 20

FRAMING AND FINISHING (continued)

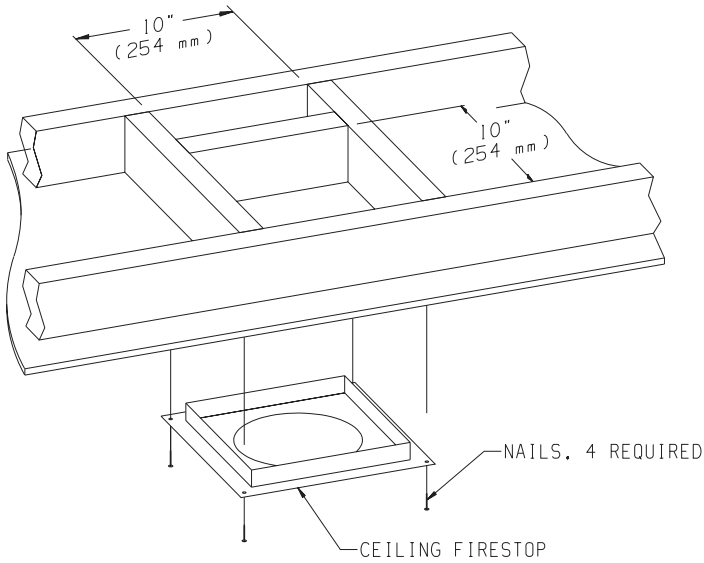

Figure 21

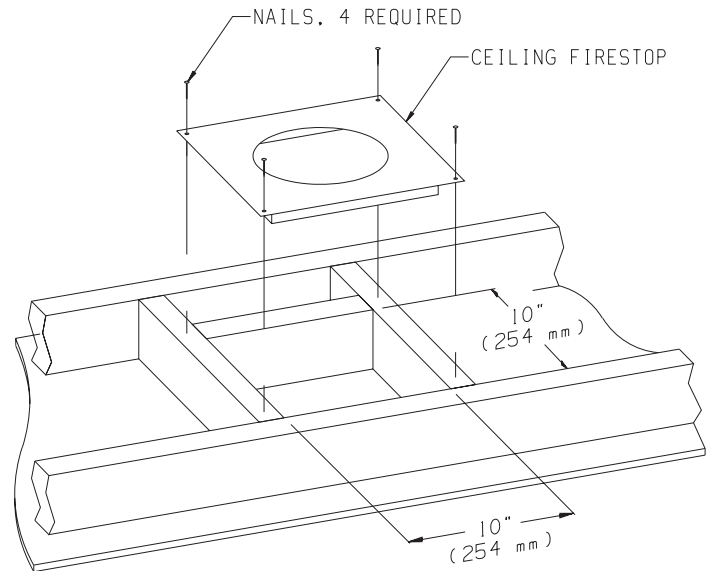

Figure 22

HORIZONTAL TERMINATION

Attach and secure the termination to the last section of horizontal venting by sliding cap over the last section of horizontal venting to ensure proper location.

NOTE: Termination cap should pass through the wall firestop from the exterior of the building. Adjust the termination cap to its final exterior position on the building.

WARNING: Termination cap must be positioned so that the arrow is pointing up.

Using the termination cap in the center of the square hole, attach the termination cap with the four wood screws provided. Before attachment of the termination, run a bead of silicone sealant rated above 250°F on its outside edge too, so as to make a seal to that exterior wall.

NOTE: Wood screws can and should be replaced with appropriate fasteners for use on stucco, brick, concrete or other types of siding.

CAUTION: If exterior walls are finished with siding (vinyl, aluminum, etc.), it is necessary to install the vinyl siding shield (46DVA-VSS).

Vinyl siding shield (46DVA-VSS) will be installed between the vent termination and the exterior wall. (See Figure 23) This horizontal vent termination bolts onto the flat portion of the vinyl siding standoff, so an air space will exist between the wall and the termination cap.

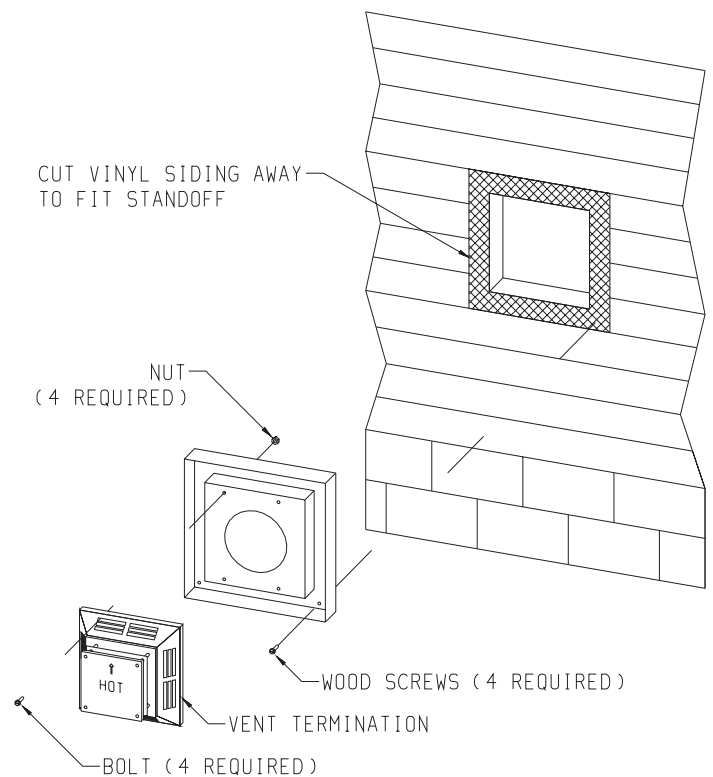

Figure 23

VERTICAL TERMINATION

Vertical Terminations (Figures 24, 25, and 26)

Locate and mark the center point of the venting pipe. Using a nail on the underside of the roof and drive this nail through this center point. Make the outline of the roof hole around this center point.

NOTE: Size of the roof hole dimensions depend on the pitch of the roof. There must be a 1 inch clearance (25 mm) to the vertical pipe sections. This clearance is to all combustible material.

Cover the opening of the vent pipe and cut and frame the roof hole. Use framing lumber the same size as the roof rafters and install the frame securely. Flashing anchored to frame must withstand high winds. The storm collar is placed over this joint to make a watertight seal. Non-hardening sealant should be used to completely seal this flashing installation.

Determining Minimum Vent Height Above the Roof.

WARNING: Major U.S. building codes specify minimum chimney and/or vent height above the roof top. These minimum heights are necessary in the interest of safety. These specifications are summarized in Figure 24.

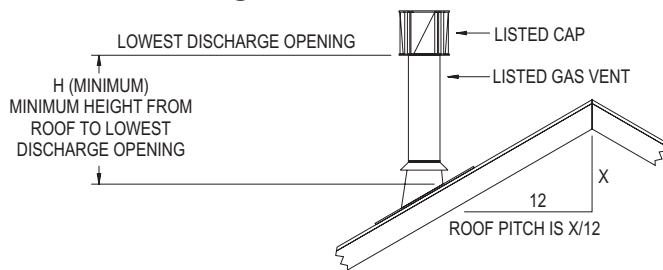

ROOF PITCH	H (MINIMUM)	
	FEET	METER
FLAT TO 6/12	1.0	0.30
6/12 TO 7/12	1.25	0.38
OVER 7/12 TO 8/12	1.5	0.46
OVER 8/12 TO 9/12	2.0	0.61
OVER 9/12 TO 10/12	2.5	0.76
OVER 10/12 TO 11/12	3.25	0.99
OVER 11/12 TO 12/12	4.0	1.22
OVER 12/12 TO 14/12	5.0	1.52
OVER 14/12 TO 16/12	6.0	1.83
OVER 16/12 TO 18/12	7.0	2.13
OVER 18/12 TO 20/12	7.5	2.27
OVER 20/12 TO 21/12	8.0	2.44

Figure 24

Note that for steep roof pitches, the vent height must be increased. In high wind conditions, nearby trees, adjoining roof lines, steep pitched roofs, and other similar factors can result in poor draft, or down-drafting. In these cases, increasing the vent height may solve this problem.

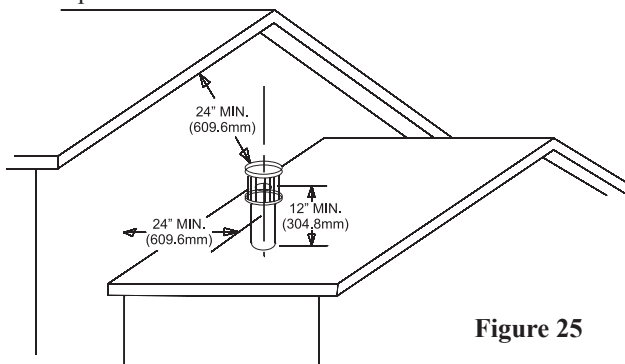

Figure 25

When terminating the vent cap near an exterior wall or overhang, maintain minimum clearances as shown in Figure 24.

General Maintenance

Conduct an inspection of the venting system semi-annually. Recommended areas to inspect are as follows:

1. Check areas of the venting system which are exposed to the elements for corrosion. These will appear as rust spots or streaks and, in extreme cases, holes. These components should immediately be replaced.
2. Remove the cap and shine a flashlight down the vent. Remove any bird nests or other foreign material.
3. Check for evidence of excessive condensate, such as water droplets forming in the inner liner and subsequently dripping out at joints. Continue condensate can cause corrosion of caps, pipe and fittings. It may be caused by having excessive lateral runs, too many elbows and exterior portions of the system being exposed to cold weather.
4. Inspect joints to verify that no pipe sections or fittings have been disturbed and, consequently, loosened. Also, check mechanical supports, such as wall straps or plumbers' tape for rigidity.

Venting terminal shall not be recessed into a wall or siding.

A removable panel or other means must be provided in the enclosure for visual inspection of the flue connection.

Installing the Vent System in a Chase

A chase is a vertical box like structure built to enclose the gas appliance and/or its vent system. Vertical vent runs on the outside of a building may be, but are not required to be installed inside a chase.

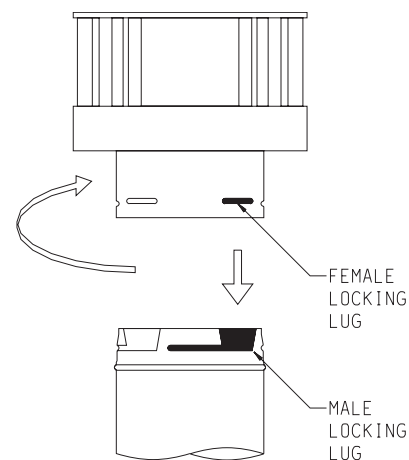

SLIDE FEMALE LOCKING LUG DOWN INTO MALE LOCKING LUG AND TWIST CLOCKWISE TO LOCK

Figure 26

CAUTION: Treatment of firestop spacers and construction of the chase may vary with the type of building. These instructions are not substitutes for the requirements of local building codes. Therefore, your local building codes must be checked to determine the requirements for these steps.

VERTICAL TERMINATION (continued)

NOTE: When installing this vent system in a chase, it is always good building practice to insulate the chase as you would the outside walls of your home. This is especially important for cold climate installations. Upon completion of building your chase framing, install the vent system by following the instructions in this manual. Remember to build the chase large enough so that minimum clearance of combustible materials (including insulation) to the vent system are maintained.

Vertical Through the Roof Applications

Your Gas Fireplace has been approved for

- a) Vertical installations up to 25 feet of vent run
- b) Two sets of 45 degree elbow offsets within these vertical installations. From 0 to a maximum of 8 feet a vent pipe can be used between elbows.
- c) Wall straps must be used to support offset pipe every 4 feet.

This applications will require that you first determine the roof pitch and use the appropriate venting components.

Reassembly and Resealing Vent-Air Intake System

Attach vent pipe to appliance air drop with (4) 1/2" hex-head screws in position, replace vertical and horizontal pipe lengths, elbows and horizontal or vertical termination kit.

All vent system components lock into place by sliding the concentric pipe section with four (4) equally spaced interior beads onto the appliance collar or previously installed component end with four (4) equally spaced indented sections. When the internal beads of each starting 6 5/8 inch outer pipe line up, rotate pipe section clockwise 90° (approximately 3 inches). The vent pipe is now locked together.

Continue replacing components per the vent system configuration. Be certain that each succeeding vent component is securely fitted and locked into the preceding component in the vent system.

Installing Support Brackets

A horizontal pipe support **MUST BE** used for each 3 feet of horizontal run. The pipe supports should be placed around 6 5/8 inch diameter pipe and nailed in place to framing members. There **MUST BE** a 2 inch clearance to combustibles above 6 5/8 inch diameter pipe and elbows and 1 inch clearance on both sides and bottom of 6 5/8 inch to combustibles on all horizontal pipe sections and elbows.

Vertical runs of this vent systems must be supported every 4 feet above the appliance flue outlet by wall brackets attached to the 6 5/8 inch vent pipe and secured with nails or screws to structural framing members.

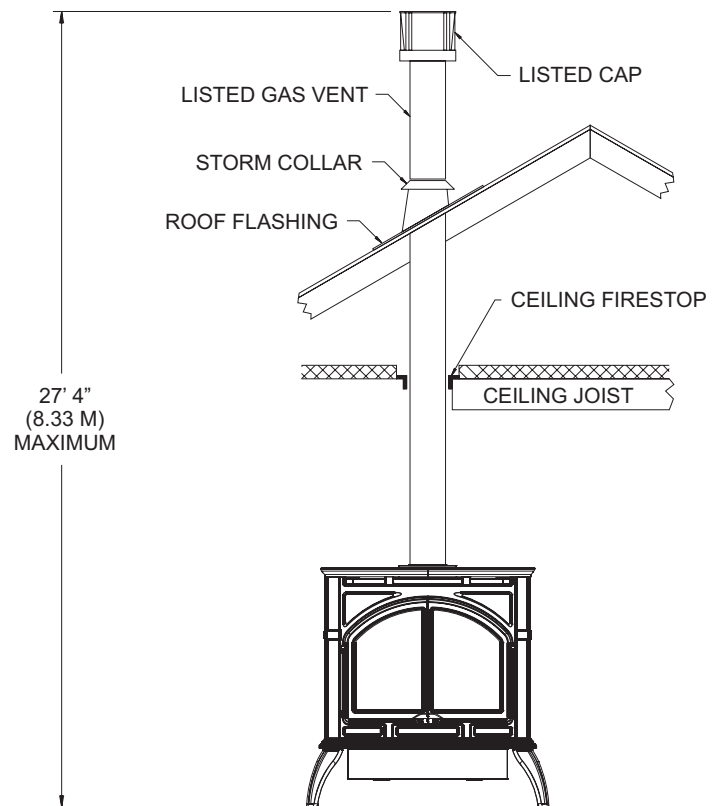

Figure 27

LOG PLACEMENT

1. Remove cast iron top and carefully set aside.
2. Remove cast iron front and carefully set aside.
3. Lower valve cover on firebox.
4. Release two door latches at bottom of firebox.
5. Grasp bottom of glass frame, lift glass frame upward in order to release glass frame from lip on top of firebox.
6. Remove logs from shipping crate. Remove all protective packaging from logs and interior of firebox.
7. Place rear log onto two (2) pins on rear log support.
8. Place center left front log onto flat portion of left side of burner.
9. Place right front log onto flat portion on right side of burner. Toe of right front log should rest in groove on ember bed twig.
10. Place front left log chunk onto flat portion of burner on left front side.
11. Place left twig onto left side pin on rear log with toe resting on the groove in the left front log.
12. Place right twig onto right side pin on rear log with toe resting all the way to the right on the right front log.
13. Align and place top of glass frame over lip on top of firebox. Grasp bottom of glass frame, push inward and place glass frame onto firebox.
14. Attach two door latches to bottom of firebox.
15. Log placement is completed.
16. Install cast iron front.
17. Install cast iron top.

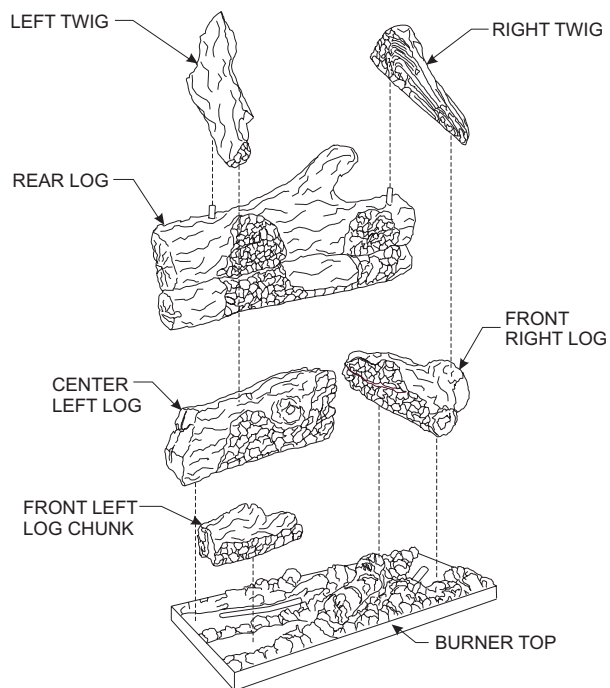
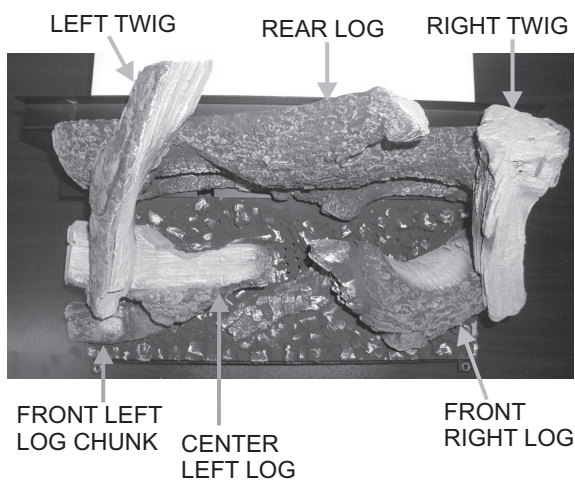

Figure 28

Refer to Figure 28 for the following warning.

Warning: Failure to position the parts in accordance with this diagram or failure to use only parts specifically approved with this appliance may result in property damage or personal injury.



Log Placement - Top View

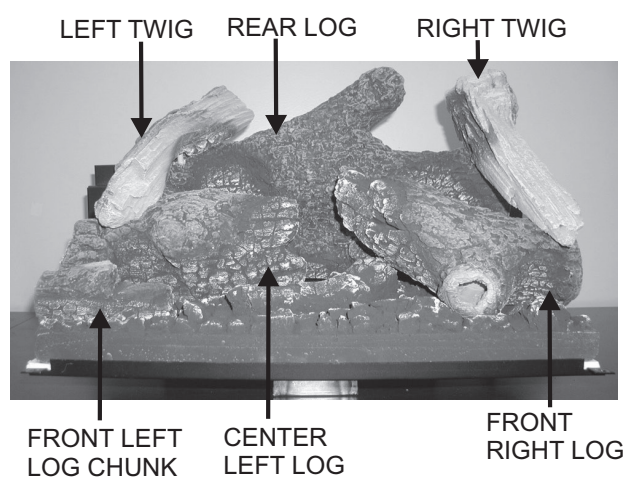

Log Placement - Front View

OPERATING GUIDELINES

Before operating this heater, please review the safety warnings pages at the beginning of this manual and those precautions and warnings listed below.

1. Know what type of ignition system this model has (standing pilot) and follow the applicable SAFETY and LIGHTING instructions.
2. Check to ensure there are no gas leaks. If you are unsure, turn gas off to the heater and call a service person or your gas utility.

CAUTION: Clothing or other flammable material should not be placed on or near the appliance.

WARNING: Children and adults should be alerted to the hazard of high surface temperature and should stay away to avoid burns or clothing ignition. Young children should be carefully supervised when they are in the same room as the appliance.

3. Tampering is DANGEROUS and voids all warranties. Any component that is found to be faulty, must be replaced with an approved component.

Initial Lighting

Upon completing the gas line or turning the gas valve "ON" after it has been in the "OFF" position, a small amount of air will be in the lines. When first lighting the appliance, it will take a few minutes for the lines to purge themselves of this air. Once the purging is complete, the appliance will light and operate satisfactorily.

Subsequent lightings of the appliance will not require such purging if the gas valve is not turned to "OFF."

Standing Pilot Operation

1. Follow the SAFETY and LIGHTING INSTRUCTIONS for standing pilot controls found in this manual and on labels found attached to the appliance.

CAUTION: During the initial purging and subsequent lightings, never allow the gas valve control knob to remain depressed in the "pilot" position without pushing the piezo ignitor button at least once every second.

2. During the heating season, leave the control valve knob in the "ON" position. This will allow the pilot flame to remain lit. Turn the burner flame on or off with the appliance REMOTE/OFF/ON rocker switch, wall switch, remote control kits or 750 millivolt wall thermostat.

NOTE: The gas control valve allows you to increase or decrease the height of the main burner flame. The control valve has a pressure regulator with a knob as shown in Figure 29. Rotate the knob clockwise to "HI" to increase the flame height and counterclockwise to "LO" to decrease the flame height.

3. When the heating season is over, turn the REMOTE/OFF/ON switch to "OFF" and the control valve to "OFF". The system, including the pilot light, will be shut down.

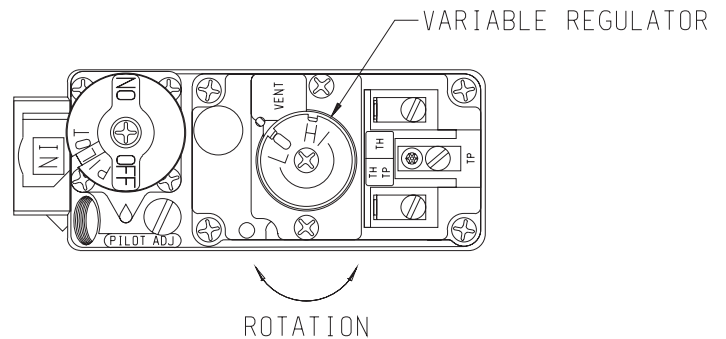

Figure 29

Maximum and Minimum Input

The gas valve on the appliance allows the input to adjust between a maximum input of 32,000 BTUh for natural gas and 30,000 BTUh for LP gas to a minimum input of 22,400 BTUh for natural gas and 22,000 BTUh for LP gas. Consumer be advised, the maximum input provides the greatest amount of yellow flame and ember glow on the log set. The minimum input substantially decreases the yellow flame and ember glow on the log set.

LIGHTING INSTRUCTIONS

FOR YOUR SAFETY READ BEFORE LIGHTING

WARNING: If you do not follow these instructions exactly, a fire or explosion may result causing property damage, personal injury or loss of life.

- A. This appliance has a pilot which must be lighted by hand. When lighting the pilot, follow these instructions exactly.
- B. **BEFORE LIGHTING** smell all around the appliance area for gas. Be sure to smell next to the floor because some gas is heavier than air and will settle on the floor.
- WHAT TO DO IF YOU SMELL GAS**
- Do not try to light any appliance.
 - Do not touch any electrical switch; do not use any phone in your building.
 - Immediately call your gas supplier from a neighbor's phone. Follow the gas supplier's instructions.
- If you cannot reach your gas supplier, call the fire department.
- C. Use only your hand to push in or turn the gas control knob. Never use tools. If the knob will not push in or turn by hand, don't try to repair it; call a qualified service technician. Force or attempted repair may result in a fire or explosion.
- D. Do not use this appliance if any part has been under water. Immediately call a qualified service technician to inspect the appliance and to replace any part of the control system and any gas control which has been under water.

LIGHTING INSTRUCTIONS

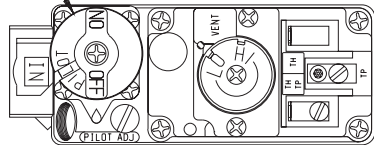

1. **STOP!** Read the safety information above.
2. Set the thermostat to lowest setting.
3. Turn off all electric power to the appliance (if applicable).
4. Lower valve cover.
5. Push in gas control knob slightly and turn clockwise  to "OFF."

GAS CONTROL KNOB SHOWN IN "OFF" POSITION.

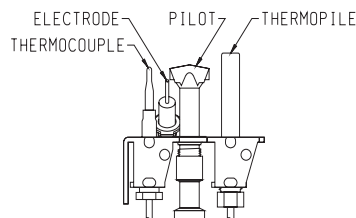

6. Wait ten (10) minutes to clear out any gas. Then smell for gas, including near the floor. If you smell gas, **STOP!** Follow "B" in the safety information above. If you don't smell gas, go to the next step.
7. Find pilot - The pilot is attached to the main burner behind the front log.



8. Turn knob on gas control counterclockwise  to "PILOT."
9. Push in gas control knob all the way and hold in. Repeatedly push the piezo ignitor button until pilot is lit. Continue to hold the control knob in for about one (1) minute after the pilot is lit. Release knob and it will pop back up. Pilot should remain lit. If it goes out, repeat steps 5 through 9.
 - If knob does not pop up when released, stop and immediately call your service technician or gas supplier.
 - If the pilot will not stay lit after several tries, turn the gas control knob to "OFF" and call your service technician or gas supplier.
10. Turn gas control knob counterclockwise  to "ON".
11. Raise valve cover.
12. Turn on all electric power to the appliance (if applicable).
13. Set thermostat to desired setting.

TO TURN OFF GAS TO APPLIANCE

1. Set the thermostat to lowest setting.
2. Turn off all electric power to appliance if service is to be performed (if applicable).
3. Lower valve cover.
4. Push in gas control knob slightly and turn clockwise  to "OFF". Do not force.
5. Raise valve cover.

PILOT FLAME CHARACTERISTICS

Figure 30 shows a correct pilot flame pattern. The correct flame will be blue and will extend beyond the thermocouple and thermopile. The flame will surround the thermocouple and thermopile just below the tip. A slight yellow flame may occur where the pilot flame and main burner flame meet. The incorrect pilot flame is not touching the thermocouple or thermopile. This will cause the thermocouple or thermopile to cool. When the thermocouple cools, the heater will shut down.

If pilot flame pattern is not correct, see Troubleshooting, page 29.

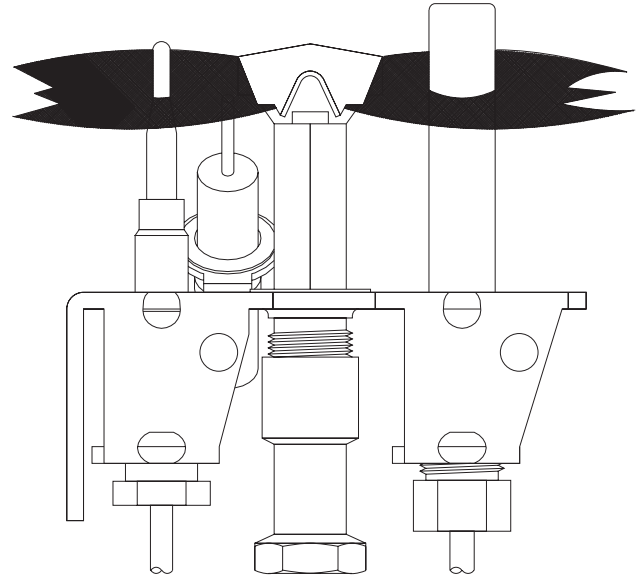

Figure 30

MAIN BURNER FLAME CHARACTERISTICS

Figure 31 shows a correct main burner flame pattern. Figure 32 shows an incorrect main burner flame pattern.

If main burner flame pattern is incorrect, as shown in Figure 32:

- See Troubleshooting, page 29.

Cleaning and Maintenance / Main Burner

Warning: Turn off heater and let cool before cleaning.

After use, cleaning of the main burner may be required for the proper flame. The main burner may be cleaned by applying pressurized air to the ports on the main burner.

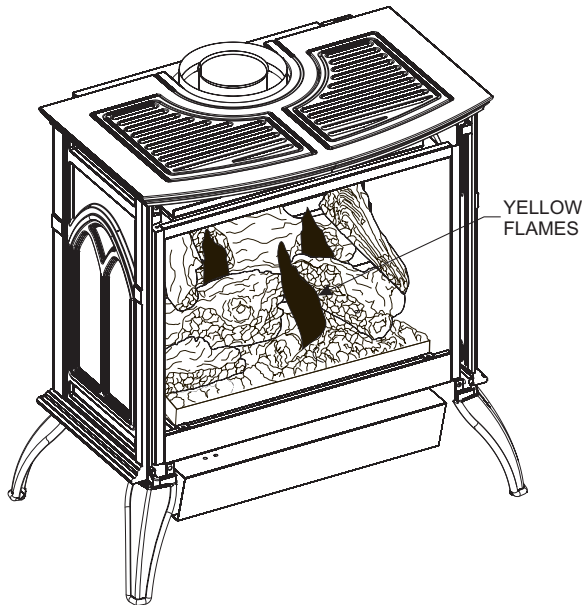

Correct Main Burner Flame

Figure 31

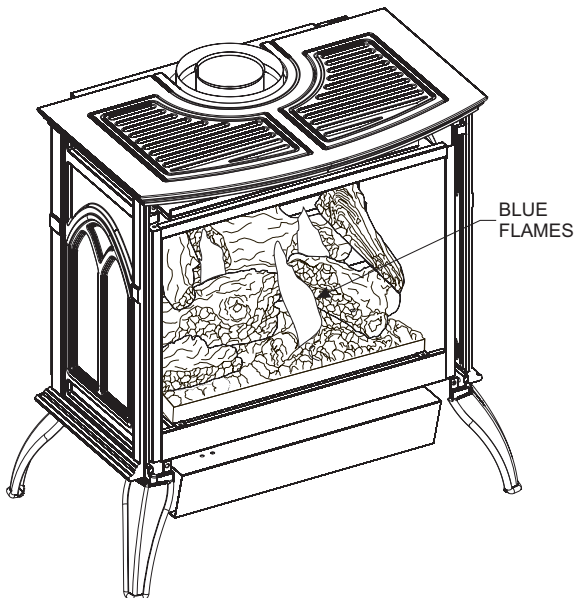

Incorrect Main Burner Flame

Figure 32

Cleaning the Log Set and Firebox

Do NOT handle these logs with your bare hands. Always wear gloves to prevent skin irritation. During the annual inspection and maintenance appointment, the service person should clean dust, lint, and any light accumulation from the logs and the firebox area. An extra-soft brush should be used on the logs as they are extremely fragile; a vacuum cleaner may be used on the firebox. If at any time the logs cannot be removed or installed without forcing, the cause must be found. The logs must never be forced.

CAUTION: The ceramic logs are durable when handled and installed properly. However, they are delicate and may be damaged easily if not handled with care. Handling damage to the ceramic logs is not covered by warranty.

DO NOT HANDLE LOGS WHILE THEY ARE HOT. ALLOW PLENTY OF TIME FOR THE APPLIANCE TO COOL COMPLETELY BEFORE HANDLING.

PLEASE NOTE

It is normal for appliances fabricated of steel to give off some expansion and/or contraction noised during the start up or cool down cycle. Similar noises are found with your furnace heat exchanger or car engine.

WIRING

DVP30C ON/OFF/REMOTE Switch

DVP30C is equipped with an ON/OFF/REMOTE switch which is located on the wire channel located on the top, left side of the stove. A wire harness is attached to the ON/OFF/REMOTE switch. The red, black and green (wires) female push-ons attach to the ON/OFF/REMOTE switch. At the opposite end of the wire harness, the black and green (wires) female push-ons attach to the gas valve. An additional green wire and the red wire, which are stripped and bare, will attach to the 750 millivolt wall thermostat accessory, or, to one of the other accessories that can be purchased for use with your log set.

Operation of ON/OFF/REMOTE Switch with no Accessories

To ignite main burner, turn the control knob on the gas valve from the PILOT position to the ON position. Turn the ON/OFF/REMOTE switch from the OFF position to the ON position. The additional green wire and red wire, which are stripped and bare are not used.

Operation of ON/OFF/REMOTE Switch with Accessories 750 Millivolt Wall Thermostat

Connect the green and red, stripped and bare, wires on the ON/OFF/REMOTE switch wire harness to the wall thermostat. Turn the ON/OFF/REMOTE switch on the wire channel to the REMOTE position. Set the wall thermostat to the desired temperature.

It is important to use wire of a gauge proper for the length of the wire:

RECOMMENDED WIRE GAUGES

Maximum Length	Wire Gauge
1' to 10'	18
10' to 25'	16
25' to 35'	14

Wall Switch, FWS

Connect the green and red, stripped and bare, wires on the ON/OFF/REMOTE switch wire harness to the wall switch. Turn the ON/OFF/REMOTE switch on the wire channel to the REMOTE position. Pivot the rocker switch on the FWS to the ON position.

Battery Operated Remote Control, FRBC, FRBTP, TRW, and FRBTC

Connect the green and red, stripped and bare, wires on the ON/OFF/REMOTE switch wire harness to the remote receiver that is a component in the FRBC and FRBTC. Turn the ON/OFF/REMOTE switch on the wire channel to the REMOTE position. Follow instructions in the FRBC and FRBTC to complete installation.

Note: If batteries fail in FRBC or FRBTC, and immediate heat is desired, turn the ON/OFF/REMOTE switch on wire channel from the REMOTE position to the ON position.

Electric (120 volt) Operated Remote Control, FREC

Connect the green and red, stripped and bare, wires on the ON/OFF/REMOTE switch wire harness to the wires on remote receiver that is a component in the FREC. Turn the ON/OFF/REMOTE switch on the wire channel to the REMOTE position. Follow instructions in the FREC to complete installation.

Note: If electric (120 volt) fails in FREC, and immediate heat is

desired, turn the ON/OFF/REMOTE switch on wire channel from the REMOTE position to the ON position.

1. Connect (1) wire from the 750 millivolt wall thermostat and (1) wire from appropriate accessory to the GREEN, stripped and bare wire from the ON/OFF/REMOTE wire harness.
2. Connect (1) wire from the 750 millivolt wall thermostat and (1) wire from appropriate accessory to the RED, stripped and bare wire from the ON/OFF/REMOTE wire harness.

Note: When the appliance is in the MANUAL mode and the batteries fail in the FRBC or if the electric (120 volt) fails in the FREC, and immediate heat is desired, turn the ON/OFF/REMOTE switch on wire channel from the REMOTE position to the ON position.

Manual Operation

1. Turn ON/OFF/REMOTE switch on wire channel to REMOTE position.
2. Turn wall thermostat OFF.
3. Turn accessory, FRBC, FREC, FRBTP, TRW, FRBTC, or FWS, ON. Appliance is now in the manual mode. You must turn the appliance ON or OFF with appropriate accessory.

Wall Thermostat Operation

1. Turn the ON/OFF/REMOTE switch on wire channel to REMOTE position.
2. Turn accessory, FRBC, FREC, FRBTP, TRW, FRBTL-1, or FWS, OFF.
3. Turn wall thermostat ON and set appropriate temperature. Wall thermostat will cycle the appliance ON and OFF.

Installation of Remote Receiver (Figure 33)

1. Attach, from left to right, the slide-on cover plate onto the remote receiver. **ON** will be to the top and **OFF** will be to the bottom on the slide-on cover plate.
2. Push the receiver slide button onto the receiver slide switch. Reverse installation of the slide button if it is off center.
3. Attach Velcro loop on the left side of the valve cover support.
4. Attach Velcro hook onto remote receiver. The word **TOP** on the remote receiver should be to the top when installed onto valve cover support.
5. Attach Velcro hook on remote receiver onto Velcro loop on valve cover support.

Refer to remote control installation and operating instructions for more details on remote control.

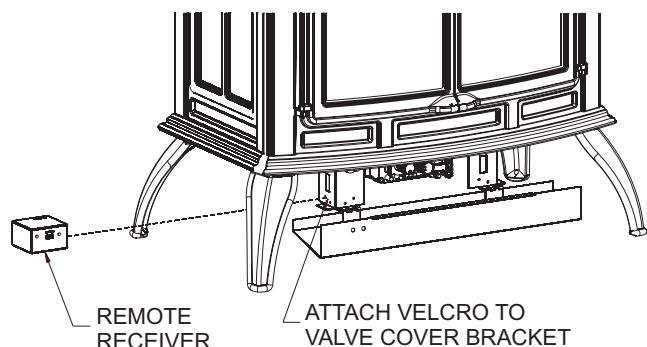
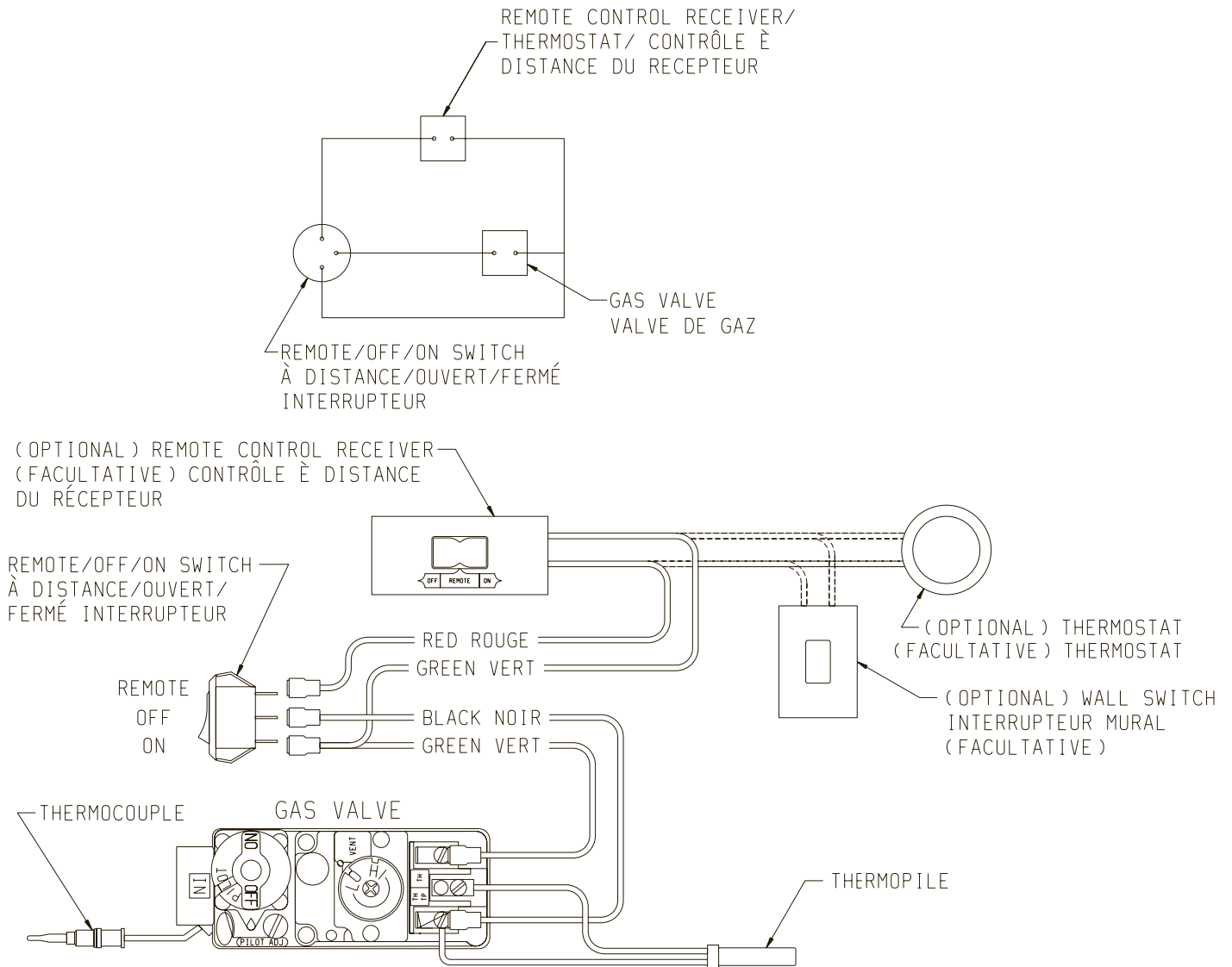

Figure 33

WIRING (continued)



IF ANY OF THE ORIGINAL WIRE AS SUPPLIED WITH THIS UNIT MUST BE REPLACED, IT MUST BE REPLACED WITH NO. 18, 150°C WIRE OR ITS EQUIVALENT.

SI UN DES FILS ÉLECTRIQUES ORIGINAUX, VENANT DU FABRICANT AVEC CETTE UNITE, DOIT ÊTRE REMPLACÉ, VOUS DEVEZ LE REMPLACER AVEC UN FIL ÉLECTRIQUE DE NUMÉRO 18, 150°C OU L'ÉQUIVALENT.

Wiring Diagram

Figure 34

MAINTENANCE

A qualified service person recommended by your Empire dealer should conduct an annual inspection and maintenance of the appliance, its venting, and the installation to keep it running safely and efficiently. The following procedures should be performed only by a qualified service person. The gas supply should be turned off whenever a maintenance procedure is performed.

If the glass front, relief doors, or front access door are removed for servicing, they must be replaced prior to operating the appliance.

Glass Cleaning

It will be necessary to clean the glass periodically. During start-up condensation, which is normal, forms on the inside of the glass and causes lint, dust and other airborne particles to cling to the glass surface. Also initial paint curing may deposit a slight film on the glass. It is therefore recommended that the glass be cleaned two or three times with a non-abrasive household cleaner and warm water (we recommend gas fireplace glass cleaner). We do not recommend using packaged spray type household glass cleaner. After that the glass should be cleaned two or three times during each heating season depending on the circumstances present.

General Glass Information

Only glass approved for use in Empire Comfort Systems Inc. fireplaces may be used for replacement. The glass replacement should be done by a licensed or qualified service person.

WARNING:

1. The use of substitute glass will void all product warranties.
2. Care must be taken to avoid breakage of the glass.
3. Under no circumstances should this appliance be operated without the glass front or with a broken glass front. Replacement of the glass (with gasket) as supplied by the manufacturer should be done by a qualified service person.
4. Do not abuse the glass by striking or hitting the glass.

WARNING: Do not use abrasive cleaners on glass. Do not attempt to clean glass when glass is hot.

Failure to follow these warnings could cause a serious safety issue to the operator, such as fire or other serious conditions.

Glass Assembly Replacement

1. Remove casting top from casting.
2. Remove casting front from casting.
3. Lower valve cover on firebox.
4. Release two door latches at bottom of firebox.
5. Grasp bottom of glass frame, lift glass frame upward in order to release glass frame from lip on top of firebox.
6. Place glass frame assembly on a non-abrasive surface. The exterior of the glass frame assembly should be facing the non-abrasive surface.
7. Insert a putty knife between glass and bottom corners on frame. Carefully separate glass from frame.
8. Use putty knife to remove silicone and gasket material from frame. Surface of frame must be clean and dry.
9. At each corner of frame apply (2) three inch beads of high temperate (orange) silicone.
10. With thin gasket on glass facing silicone on frame, insert glass into frame. Carefully press the glass onto frame in order to have contact between glass and silicone.
11. Allow silicone to set-up for an adequate time
12. Align and place top of glass frame over lip on top of firebox. Grasp bottom of glass frame, push inward and place glass frame onto firebox.
13. Attach two door latches to bottom of firebox.
14. Replace casting front onto casting.

15. Replace casting top onto casting.
16. Replacement of glass assembly is completed.
SHOWN WITH TOP & FRONT REMOVED

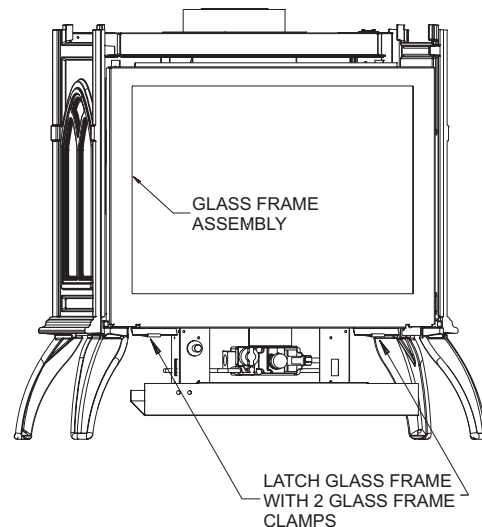

Figure 35

IMPORTANT: Turn off gas before servicing appliance. It is recommended that a competent service technician perform these check-ups at the beginning of each heating season.

- **DO NOT put anything around the heater that will obstruct the flow of combustion and ventilation air. See clearances.**
- **DO examine venting system periodically. Clean and replace damaged parts. Examinations should be made at the start of the heating season and also in mid heating season under average conditions.**
- **Clean Burner and Control Compartment**
Keep the control compartment, logs, and burner areas surrounding the logs clean by vacuuming or brushing at least twice a year.

Cleaning Procedure

1. Let the unit cool if it has been operating.
2. Shut off gas supply.
3. Lower valve cover on firebox.
4. Release two door latches at bottom of firebox.
5. Grasp bottom of glass frame, lift glass frame upward in order to release glass frame from lip on top of firebox.
6. Vacuum burner compartment especially around orifice/primary air openings.
7. Align and place top of glass frame over lip on top of firebox. Grasp bottom of glass frame, push inward and place glass frame onto firebox.
8. Attach two door latches to bottom of firebox.
9. Ignite pilot. (See **Lighting Instructions**, Page 23)
10. Operate the main burner and visually check to make sure the flame pattern appears similar to the pictorial illustration shown for **Main Burner Flame Characteristics**, Figure 31. If it appears abnormal call a service person.

TROUBLESHOOTING

With proper installation and maintenance, your new Direct Vent Fireplace should provide years of trouble-free service. If you do experience a problem, refer to the Trouble Shooting Guide below. This guide will assist a qualified service person in the diagnosis of problems and the corrective action to be taken.

- 1. Spark ignitor will not light pilot after repeated depressing of piezo ignitor button.**
 - a. Defective ignitor (no spark at electrode) - Check for spark at electrode and pilot; if no spark and electrode wire is properly connected, replace ignitor.
 - b. No gas or low gas pressure.
 - Check remote shut off valves from fireplace. Usually there is a valve near the main. There can be more than one (1) valve between the fireplace and main.
 - Low pressure can be caused by a variety of situations such as a bent line, too narrow diameter of pipe, or low line pressure. Consult with plumber of gas supplier.
 - c. No LP in tank.
 - Check LP (propane) tank. Refill tank.
 - 2. Pilot will not stay lit after carefully following lighting instructions.**
 - a. Defective thermocouple.
 - Check that pilot flame impinges on thermocouple. Clean and/or adjust pilot for maximum flame impingement.
 - Ensure that the thermocouple connection at the gas valve is fully inserted and tight (hand tight plus 1/4 turn) faulty thermopile if reading is below specified minimum.
 - Disconnect the thermocouple from the valve, place one millivolt meter lead wire on the tip of the thermocouple and the other meter lead wire on the thermocouple copper lead. Start the pilot and hold the valve knob in. If the millivolt reading is less than 15 MV, replace the thermocouple.
 - b. Defective valve.
 - If thermocouple is producing more than 15 millivolts, replace faulty valve
 - 3. Pilot burning, no gas to burner, valve knob "ON", on/off switch "ON."**
 - a. "On/Off" switch, wall switch, or wires defective.
 - Check "on/off" switch and wires for proper connections. Place jumper wires across terminal at switch - if burner comes on, replace defective switch. If OK, place jumper wires across switch wires at gas valve-if burner comes on, wires are faulty or connections are bad.
 - b. Thermopile may not be generating sufficient millivoltage.
 - If the pilot flame is not close enough physically to the thermopile, adjust the pilot flame.
 - Be sure the wire connections from the thermopile at the gas valve terminals are tight and the thermopile is fully inserted into the pilot bracket.
 - Check the thermopile with a millivolt meter. Take the reading at TH-TP & TP terminals of the gas valve. The meter should read 325 millivolts minimum, while holding the valve knob depressed to the pilot position, with the pilot lit, and the ON/OFF switch in the OFF position. Replace the faulty thermopile if the reading is below the specified minimum.
 - With the pilot in the ON position, disconnect the thermopile leads from the valve. Take a reading at the thermopile leads. The reading should be 325 millivolts minimum. Replace the thermopile if the reading is below the minimum.
 - c. Defective valve.
 - Turn valve knob to "ON." Place ON/OFF switch to "ON." Check with millivolt meter at thermopile terminals. Millivolt meter should read greater than 100 M.V. If the reading is okay and the burner does not come, replace the gas valve.
 - d. Plugged main burner orifice.
 - Check main burner orifice for blockage, clean main burner orifice.
- 4. Frequent pilot outage problem.**
 - a. Pilot flame may be too high or too low, or blowing (high), causing pilot safety to drop out.
 - Clean and adjust flame for maximum flame impingement on the thermocouple. Follow lighting instructions carefully.
- 5. The pilot and main burner extinguish while in operation.**
 - a. No LP (Propane) in tank.
 - Check LP (Propane) tank. Refill fuel tank.
 - b. Inner vent pipe leaking exhaust gases back into system.
 - Check for leaks.
 - c. Glass too loose, gasket leaks in corners after usage.
 - Be certain glass assembly is installed correctly and tighten corner.
 - d. Horizontal vent improperly pitched.
 - The horizontal vent cap should slope down only enough to prevent any water from entering the unit. The maximum downwards slope is 1/4 inch.
 - e. Bad thermopile or thermocouple.
 - Replace if necessary.
 - f. Improper vent cap installation.
 - Check for proper installation and freedom from debris or blockage.
- 6. Glass soots.**
 - a. Flame impingement on logs.
 - Adjust the log set so that the flame does not excessively impinge on it.
- 7. Flame lifts off main burner.**
 - a. Insufficient oxygen being supplied.
 - Check to make sure vent cap is installed properly and free of debris. Make sure that vent system joints are tight and have no leaks.
 - Check to make sure that no material has been placed at the burner base.
 - Be sure glass is tightened properly on unit, particularly on top corners.

PARTS LIST

PLEASE NOTE: When ordering parts, it is very important that part number and description of part coincide.

INDEX NUMBER	PART NUMBER	DESCRIPTION
1	R-9672	INLET VENT COLLAR
2	M-178	INLET COLLAR GASKET
3	17155	FLUE OUTLET ASSEMBLY
4	M-163	FLUE OUTLET GASKET (3 REQUIRED)
5	24176	AIR DROP ASSEMBLY
6	R-9678	AIR DROP ASSEMBLY TRANSITION GASKET
7	24015	AIR DROP TRANSITION
8	R-9679	FIREBOX TRANSITION GASKET
9	17379	BLOW PLATE BRACKET (2 REQUIRED)
10	24398	BLOW PLATE ASSEMBLY
11	23937	FIREBOX TOP
12	24173	FLUE RESTRICTOR
13	24018	FIREBOX WALLS
14	24017	REAR LOG SUPPORT
15	24185	GLASS FRAME ASSEMBLY
16	R-5143	PILOT ASSEMBLY - NAT
16	R-5144	PILOT ASSEMBLY - LPG
17	15512	PILOT BRACKET
18	24180	BURNER ASSEMBLY
19	P-253	ORIFICE ANGLED FITTING
20	24429	ORIFICE HOLDER BRACKET
21	R-7572	JAMB NUT
22	P-244	ORIFICE #33 - LPG
22	P-185	ORIFICE #52 - NAT
23	26561	AIR SHUTTER BRACKET
24	23939	FIREBOX BOTTOM
25	M-174	GASKET

INDEX NUMBER	PART NUMBER	DESCRIPTION
26	11269	GAS LINE BRACKET
27	M-157	SILICONE RUBBER GASKET
28	DVF-039	SEAL BRACKET
29	R-4053	DOOR CLAMP (2 REQUIRED)
30	15490	VALVE BRACKET
31	24024	TUBING ASSEMBLY (VALVE TO BURNER)
32	R-2423	5/16 MALE CONNECTOR
33	R-3318	VALVE - NAT
33	R-3319	VALVE - LPG
34	24203	TUBING ASSEMBLY (VALVE TO PILOT)
35	R-9760	PIEZO IGNITER
36	15516	VALVE COVER ASSEMBLY
37	R-9616	LOG - CHUNK
38	R-9615	FRONT LEFT LOG
39	R-9613	REAR LOG
40	R-9618	LOG - LEFT TWIG
41	R-9617	LOG - RIGHT TWIG
42	R-9614	FRONT RIGHT LOG
43	24025	REAR COVER - RIGHT
44	24026	REAR COVER - LEFT
45	26049	WIRE CHANNEL - RIGHT
46	26050	WIRE CHANNEL - LEFT
47	R-3436	REMOTE/OFF/ON SWITCH
NOT SHOWN	R-9698	WIRE ASSEMBLY
NOT SHOWN	24187	AIR RESTRICTOR INLET - LPG (2 REQUIRED)
NOT SHOWN	24206	AIR RESTRICTOR INLET - NAT (2 REQUIRED)

USE ONLY MANUFACTURER'S REPLACEMENT PARTS. USE OF ANY OTHER PARTS COULD CAUSE INJURY OR DEATH.

HOW TO ORDER REPAIR PARTS

Parts can be ordered only through your service person or dealer. For best results, the service person or dealer should order parts through the distributor. Parts can be shipped directly to the service person/dealer.

All parts listed in the Parts List have a Part Number. When ordering parts, first obtain the Model Number from the name plate on your equipment. Then determine the Part Number (not the Index Number) and the Description of each part from the following appropriate illustration and list. Be sure to give all this information.

Heater Model Number _____ Heater Serial Number _____

Part Number _____ Part Description _____

Type of Gas (Propane or Natural) _____

Do not order bolts, screws, washers or nuts. They are standard hardware items and can be purchased at any local hardware store.

Shipments contingent upon strikes, fires and all causes beyond our control.

PARTS VIEW

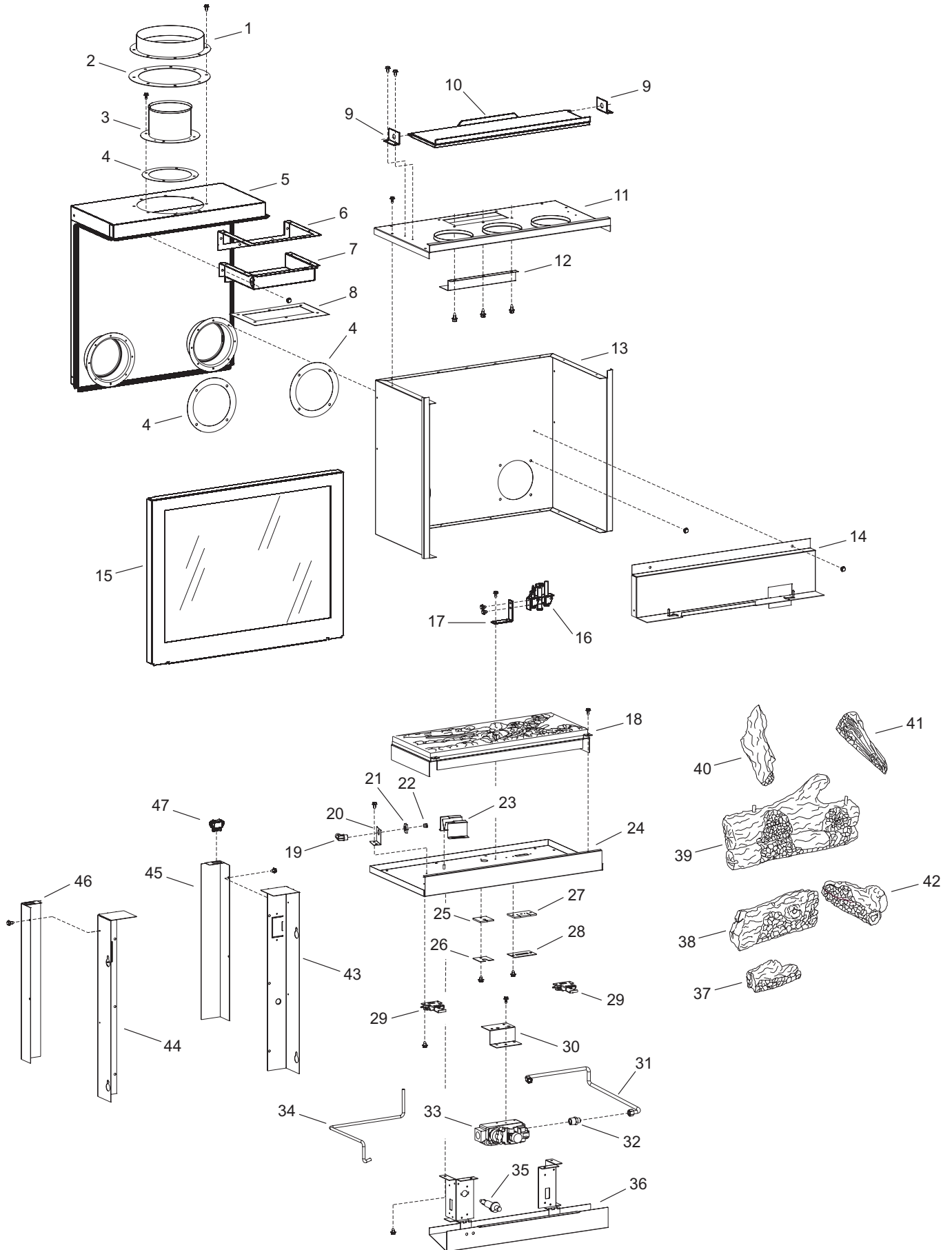

CASTING PARTS LIST

PLEASE NOTE: When ordering parts, it is very important that part number and description of part coincide.

INDEX NO.	PART NO.	DESCRIPTION
COMMON PARTS		
10	R-9671	INSERT TAB (4 REQUIRED)
NOT SHOWN	R-9669	HINGE PIN (4 REQUIRED)
NOT SHOWN	R-9670	BOLT, 1/4-20 X 1/2" (24 REQUIRED)
MATTE BLACK		
1	R-9538	TOP INSERT - RIGHT
2	R-9537	TOP INSERT - LEFT
3	R-9536	CASTING TOP
4	R-9666	CASTING FRONT
5	R-9535	CASTING SIDE - RIGHT
6	R-9534	CASTING SIDE - LEFT
7	R-9668	CASTING DOOR - RIGHT
8	R-9667	CASTING DOOR - LEFT
9	24042	FIREBOX SUPPORT BRACKET (2 REQUIRED)
11	R-9533	CASTING LEG B
12	R-9532	CASTING LEG A
MATTE PEWTER		
1	R-9554	TOP INSERT - RIGHT
2	R-9553	TOP INSERT - LEFT
3	R-9552	CASTING TOP
4	R-9693	CASTING FRONT
5	R-9551	CASTING SIDE - RIGHT
6	R-9550	CASTING SIDE - LEFT
7	R-9695	CASTING DOOR - RIGHT
8	R-9694	CASTING DOOR - LEFT
9	24042	FIREBOX SUPPORT BRACKET (2 REQUIRED)
11	R-9549	CASTING LEG B
12	R-9548	CASTING LEG A

INDEX NO.	PART NO.	DESCRIPTION
PORCELAIN BLACK		
1	R-9570	TOP INSERT - RIGHT
2	R-9569	TOP INSERT - LEFT
3	R-9568	CASTING TOP
4	R-9681	CASTING FRONT
5	R-9567	CASTING SIDE - RIGHT
6	R-9566	CASTING SIDE - LEFT
7	R-9683	CASTING DOOR - RIGHT
8	R-9682	CASTING DOOR - LEFT
9	24191	FIREBOX SUPPORT BRACKET (2 REQUIRED)
11	R-9565	CASTING LEG B
12	R-9564	CASTING LEG A
PORCELAIN SAND		
1	R-9586	TOP INSERT - RIGHT
2	R-9585	TOP INSERT - LEFT
3	R-9584	CASTING TOP
4	R-9700	CASTING FRONT
5	R-9583	CASTING SIDE - RIGHT
6	R-9582	CASTING SIDE - LEFT
7	R-9702	CASTING DOOR - RIGHT
8	R-9701	CASTING DOOR - LEFT
9	24191	FIREBOX SUPPORT BRACKET (2 REQUIRED)
11	R-9581	CASTING LEG B
12	R-9580	CASTING LEG A
PORCELAIN MAHOGANY		
1	R-9602	TOP INSERT - RIGHT
2	R-9601	TOP INSERT - LEFT
3	R-9600	CASTING TOP
4	R-9707	CASTING FRONT
5	R-9599	CASTING SIDE - RIGHT
6	R-9598	CASTING SIDE - LEFT
7	R-9709	CASTING DOOR - RIGHT
8	R-9708	CASTING DOOR - LEFT
9	24191	FIREBOX SUPPORT BRACKET (2 REQUIRED)
11	R-9597	CASTING LEG B
12	R-9596	CASTING LEG A

USE ONLY MANUFACTURER'S REPLACEMENT PARTS. USE OF ANY OTHER PARTS COULD CAUSE INJURY OR DEATH.

CASTING PARTS VIEW

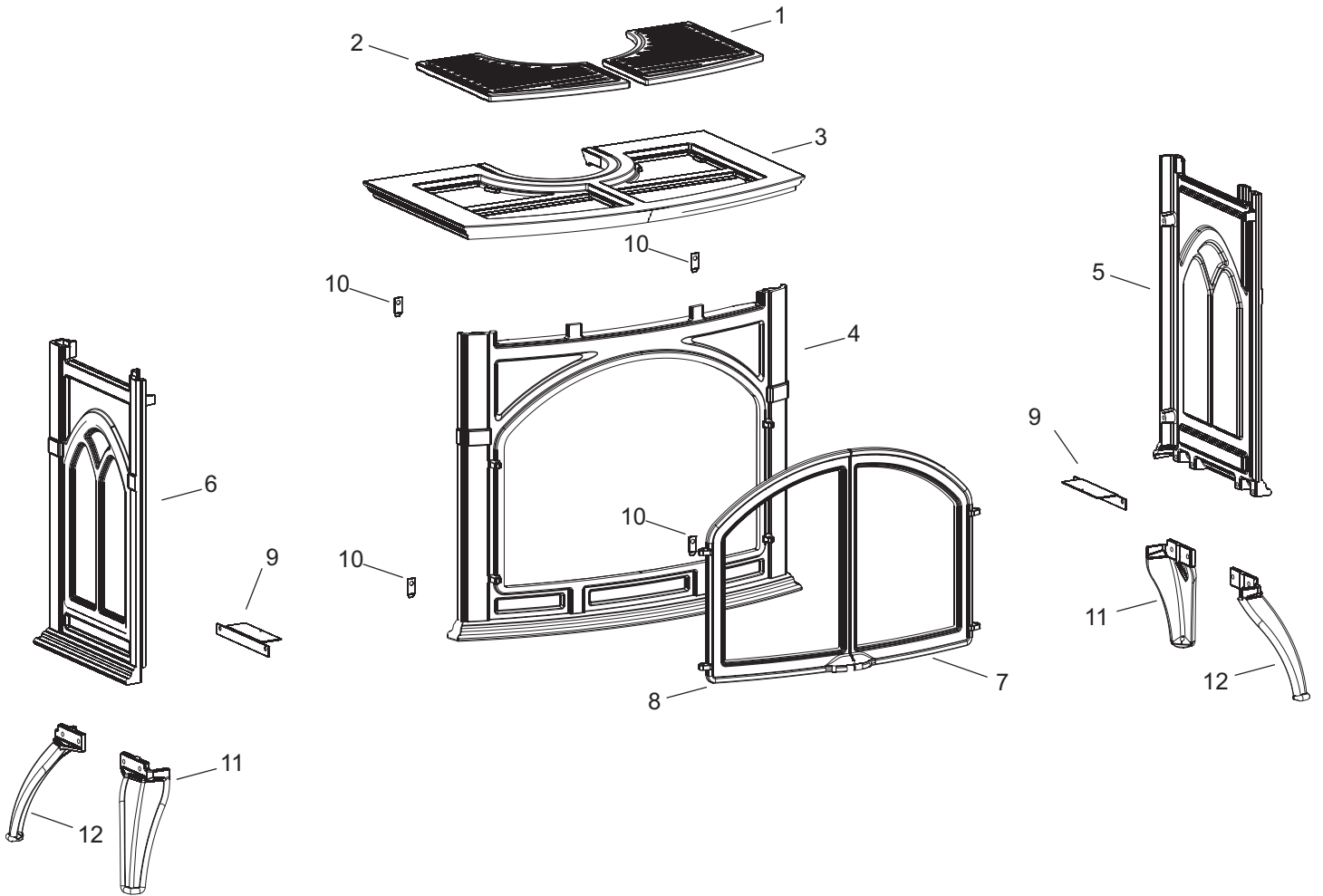

ACCESSORY SIDE SHELVES INSTALLATION INSTRUCTIONS

Installing Accessory Side Shelves:

1. Remove cast iron or stone inlay inserts from casting top and carefully set them aside.
2. Remove cast iron top from stove and place upside down on a flat, soft smooth surface to avoid damage.
3. Remove (4) 1/4-20 hex head bolts from the outer edges of cast iron top.
4. Place left and right side shelves in place shown in Figure 36.
5. Replace (4) 1/4-20 hex head bolts to attach side shelves to cast iron top, be sure shelf is tight to casting top before fully tightening bolts.
6. Remove (8) 1/4-20 hex head bolts from side shelves.
7. Replace cast iron top on unit.
8. Attach side shelf supports one at a time, using (2) 1/4-20 hex head bolts per support, sliding support flush to casting before fully tightening bolts as shown in Figure 37.
9. Replace cast iron or stone inlay inserts into casting top.

Note: Be sure to remove side shelf supports prior to removing cast iron top to eliminate potential scratching or chipping to the cast iron sides.

Note: Due to inherent properties of the casting process, non-combustible shims may be required to level accessory side shelves to the casting top. These shims are provided in the form of washers to be used on either side of the bolts. See Figure 36. If accessory shelf angles downward, toward the floor, washer(s) will need to be added to the center side of the bolt. Conversely, if the accessory side shelf angles upward, toward the ceiling, washer(s) will need to be added to the outside of the top casting side of the bolt. See Figure 39.

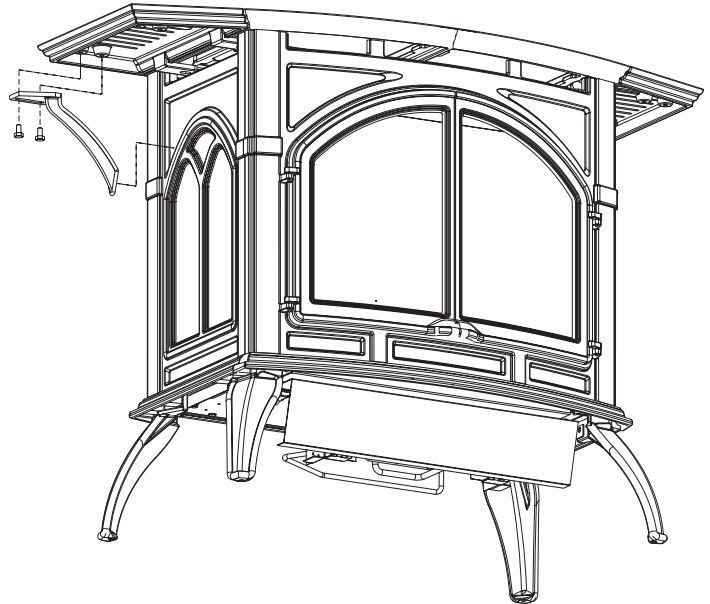
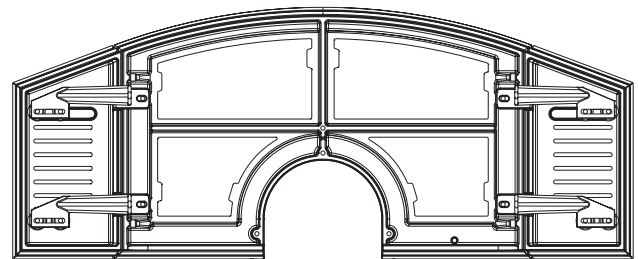

Figure 37



BOTTOM VIEW

Figure 38

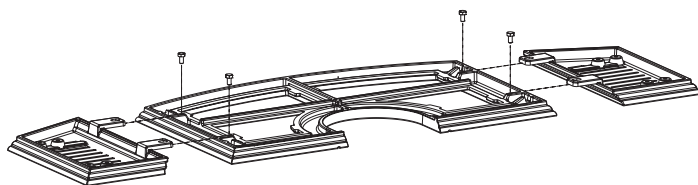
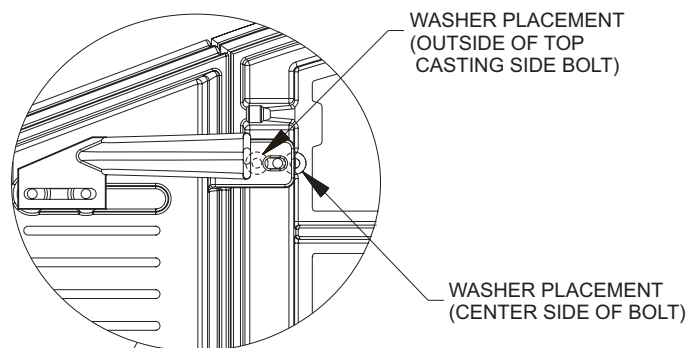
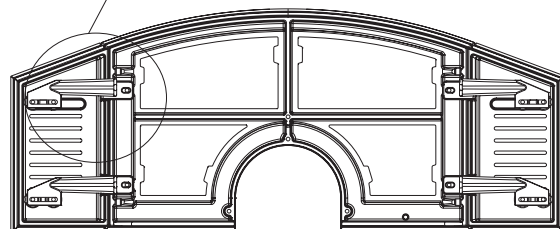

Figure 36



WASHER PLACEMENT
(OUTSIDE OF TOP
CASTING SIDE BOLT)

WASHER PLACEMENT
(CENTER SIDE OF BOLT)



BOTTOM VIEW

Figure 39

OPTIONAL BLOWER INSTALLATION INSTRUCTIONS

Installing Optional CIB3 Blower

1. Loosen, but do not remove, four (4) hex-head screws located on the exterior, bottom of the appliance.
2. Position the blower assembly at the rear of the appliance. The blower assembly has four (4) keyholes for attachment to the exterior, bottom of the appliance.
3. Place the large diameter holes in the keyholes over and behind the four (4) hex-head screws that were loosened in Step 1. Push inward on the blower assembly to lock the keyholes into position behind the screws. Tighten four (4) hex-head screws to secure blower assembly to exterior, bottom of the appliance.
4. Remove wire channel-left from appliance by removing (2) 10 x 1/2" screws on left side of the appliance. Note: Some units require a new wire channel. If Rheostat mounting holes are missing from part removed from unit, discard wire channel removed from unit and continue installation with appropriate wire channel shipped with blower. See Figure 40.
5. Route fan control wires through rectangular notch on wire channel - left.
6. Attach 1/4" push-on terminal from blue wire on the fan control to the AUTO (top) tab on the switch.
7. Attach 1/4" push-on terminal from black wire to the OFF (middle) tab on the switch.
8. Attach 1/4" push-on terminal from white wire on the fan control to the ON (bottom) tab on the switch.
9. Insert AUTO/OFF/ON switch into rectangular notch on wire channel - left.
10. Install rheostat through hole in wire channel and align small tab with small hole.
11. Use an 11/16" wrench to tighten rheostat nut on stationary portion of knob stem of the rheostat. Note: Nut is self-tapping and can be started at an angle.
12. Push rheostat knob onto knob stem until fully seated.
13. Bend the fan control tab, located on the left side of the back of the unit, inward toward the unit. See Figure 40. Be sure tab is bent at least 90 degrees to allow fan control bracket to slide into slot.
14. Attach fan control with bracket onto rear cover with two (2) 10 x 1/2" screws provided in hardware package.
15. Route wires from fan control and ON/OFF/REMOTE switch within wire channel.
16. Attach wire channel to channel divider with two (2) 10 x 1/2" screws from Step 4.
17. Installation of optional CIB3 blower is completed.

Fan Control

The fan control is a non-adjustable automatic type. The fan control will require between 5 and 10 minutes of main burner operation before the fan control "closes" and activates the blower. The blower will continue to run between 5 and 10 minutes after the main burner shuts off, before the fan control "opens" and deactivates the blower.

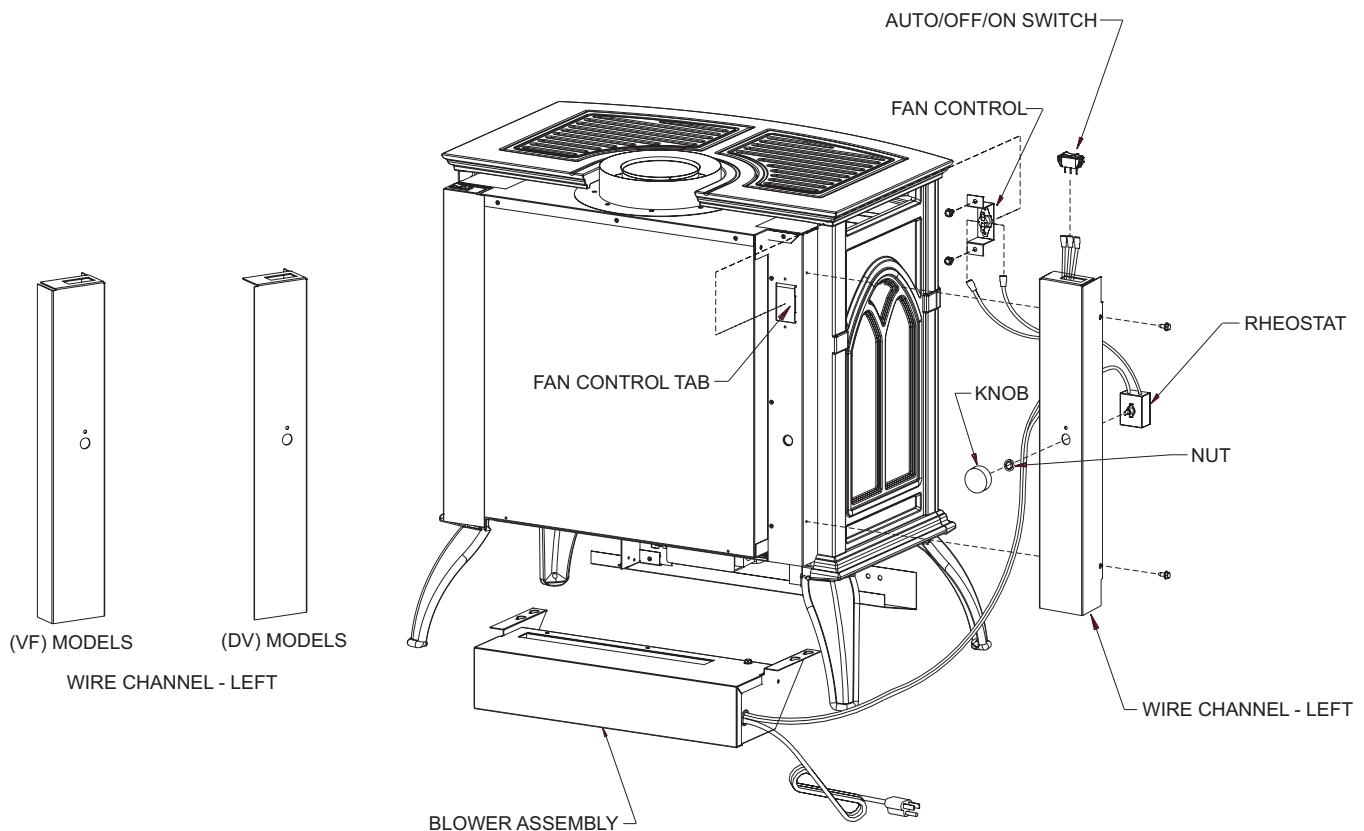

Figure 40

OPTIONAL BLOWER INSTALLATION INSTRUCTIONS

Cleaning

The blower wheel will collect lint and could require cleaning once a year. If the air output decreases or the noise level increases, it indicates a dirty wheel.

Blower Motor

The blower motor does not have oiling holes. Do not attempt to oil blower motor.

Wiring

The appliance, when installed, must be electrically grounded in accordance with local codes or, in the absence of local codes, with the *National Electrical Code, ANSI/NFPA 70* or *Canadian Electrical Code, CSA C22.1*, if an external electrical source is utilized. **This appliance is equipped with a three-prong [grounding] plug for your protection against shock hazard and should be plugged directly into a properly grounded three-prong receptacle. Do not cut or remove the grounding prong from this plug.** For an ungrounded receptacle, an adapter, which has two prongs and a wire for grounding, can be purchased, plugged into the ungrounded receptacle and its wire connected to the receptacle mounting screws. With this wire completing the ground, the appliance cord plug can be plugged into the adapter and be electrically grounded.

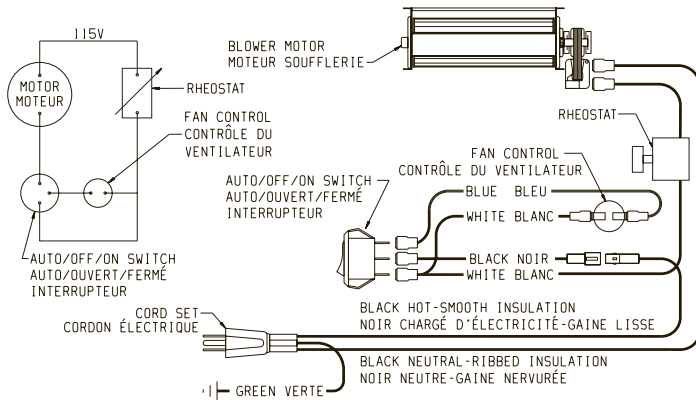

IF ANY OF THE ORIGINAL WIRE AS SUPPLIED WITH THIS UNIT MUST BE REPLACED, IT MUST BE REPLACED WITH NO. 18, 150°C WIRE OR ITS EQUIVALENT. SI UN DES FILS ÉLECTRIQUES ORIGINAUX, VENANT DU FABRICANT AVEC CETTE UNITÉ, DOIT ÊTRE REMPLACÉ, VOUS DEVEZ LE REMPLACER AVEC UN FIL ÉLECTRIQUE DE NUMÉRO 18, 150°C OU L'ÉQUIVALENT.

Figure 41

CAUTION: Label all wires prior to disconnection when servicing controls. Wiring errors can cause improper and dangerous operation. Verify proper operation after servicing.

WARNING:

Unplugging of blower accessory will not stop the heater from cycling. To shut heater off: Turn temperature dial or thermostat to lowest setting. Turn knob on gas control to "OFF," depressing slightly. Do not force.

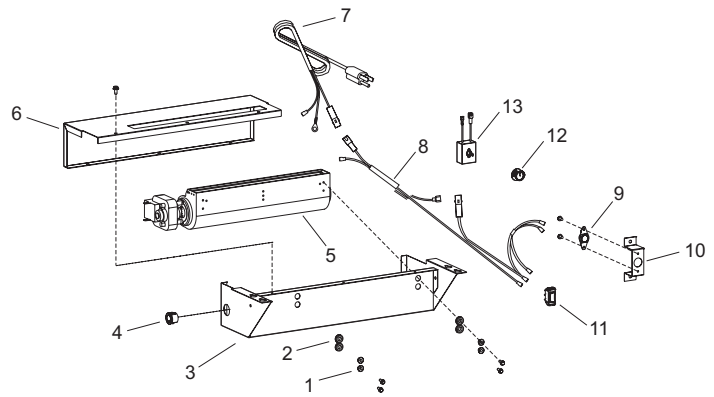

PARTS LIST

INDEX NUMBER	PART NUMBER	DESCRIPTION
1	R-1454	BRASS BUSHING
2	R-1499	RUBBER GROMMET
3	24231	BLOWER HOUSING
4	R-1410	STRAIN RELIEF BUSHING
5	R-9927	BLOWER ASSEMBLY
6	24225	BLOWER COVER
7	R-6159	CORD SET
8	R-9699	WIRE HARNESS
9	R-2503	FAN CONTROL
10	24222	FAN CONTROL BRACKET
11	R-2805	AUTO OFF/ON SWITCH
12	R-4192	RHEOSTAT KNOB
13	18879	RHEOSTAT



Empire Comfort Systems
 918 Freeburg Avenue
 Belleville, Illinois 62220-2623

Web Site: www.empirecomfort.com

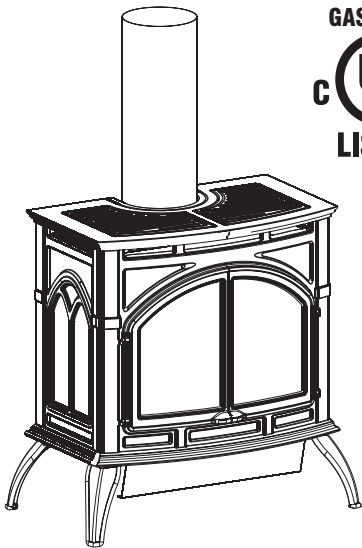

The Heritage Cast Iron Stoves Models:

DVP30CA30B, DVP30CA30F, DVP30CA30S, DVP30CA30W
 DVP30CB30B, DVP30CB30F, DVP30CB30S, DVP30CB30W

Specifications			
Model		DVP30C(A,B)30(B,F,S,W)	
		LP	NAT
Input	BTU/HR (KW/H) Maximum	30,000 (9.3)	32,000 (9.3)
	BTU/HR (KW/H) Minimum	22,000 (5.9)	22,400 (6.5)
Height		27 3/4" (705 mm)	
Width		28 1/16" (713 mm)	
Depth		17 3/8" (442 mm)	
Gas Inlet (Pipe)		1/2" (13 mm)	

CLEARANCES

In selecting a location for installation, it is necessary to provide adequate accessibility clearances for servicing and proper operation.

Locating and Venting the Direct Vent Fireplace

Clearances: When facing the front of the direct vent fireplace the minimum clearances to combustible construction (material) are the following:

Top of appliance (ceiling)	36 (inches)	Heater Corners (45° angle) to Wall	4 (inches)
Rear Wall	1 (inches)	Floor	0 (inches)
Side Wall	6 (inches)		

Installation on Rugs and Tile

This appliance must be installed on a flat, solid, continuous surface (e.g. wood, metal, concrete). This may be the floor, or it may be raised up on a platform to enhance its visual impact. The appliance may be installed on carpeting, tile, wood flooring or other combustible material as the appliance's base extends the width and depth of the appliance.

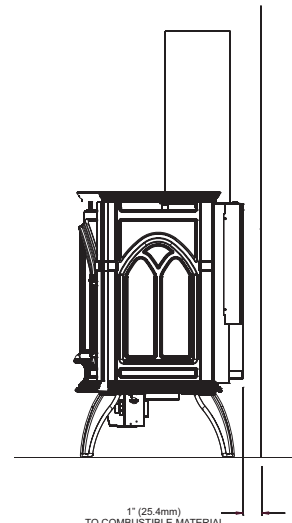
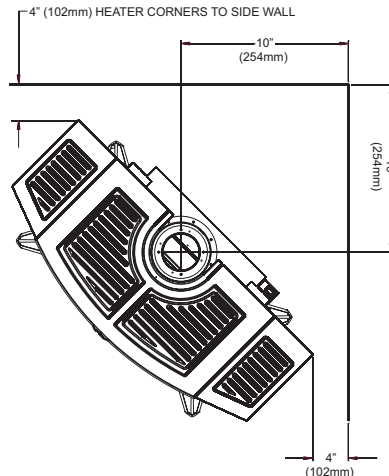
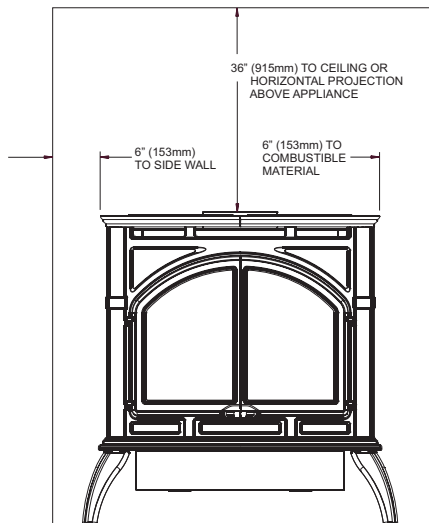

NOTE: HEATER INSTALLED AT 45° ANGLE IN CORNER



Empire Comfort Systems Inc.
918 Freeburg Ave. Belleville, IL 62220

If you have a general question about our products, please e-mail us at
info@empirecomfort.com.

If you have a service or repair question, please contact your dealer.

www.empirecomfort.com