

EMPIRE

COMFORT SYSTEMS

INSTALLATION INSTRUCTIONS AND OWNER'S MANUAL

The Heritage Cast Iron Stoves

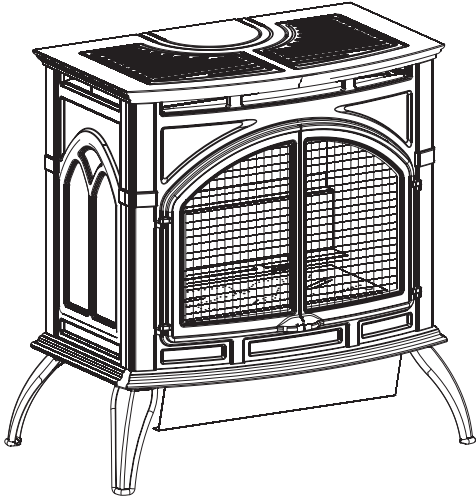

GAS-FIRED



LISTED

This appliance may be installed in an aftermarket, permanently located, manufactured (mobile) home, where not prohibited by local codes.

This appliance is only for use with the type of gas indicated on the rating plate. This appliance is not convertible for use with other gases.

WARNING: If the information in these instructions are not followed exactly, a fire or explosion may result causing property damage, personal injury or loss of life.

- Do not store or use gasoline or other flammable vapors and liquids in the vicinity of this or any other appliance.
- **WHAT TO DO IF YOU SMELL GAS**
 - Do not try to light any appliance.
 - Do not touch any electrical switch; do not use any phone in your building.
 - Immediately call your gas supplier from a neighbor's phone. Follow the gas supplier's instructions.
 - If you cannot reach your gas supplier, call the fire department.
- Installation and service must be performed by a qualified installer, service agency or the gas supplier.

CAST IRON UNVENTED ROOM HEATER

MODELS

VFP30CA30(B,F,M,S,W)N-3
VFP30CA30(B,F,M,S,W)P-3

NATIONAL
FIREPLACE
INSTITUTE



CERTIFIED
www.nficertified.org

We suggest that our gas hearth products be installed and serviced by professionals who are certified in the U.S. by the National Fireplace Institute® (NFI) as NFI Gas Specialists.

Installer: Leave this manual with the appliance.

Consumer: Retain this manual for future reference.

This is an unvented gas-fired heater. It uses air (oxygen) from the room in which it is installed. Provisions for adequate combustion and ventilation air must be provided. Refer to page 7.

WARNING: If not installed, operated and maintained in accordance with the manufacturer's instructions, this product could expose you to substances in fuel or from fuel combustion which can cause death or serious illness.

WATER VAPOR: A BY-PRODUCT OF UNVENTED ROOM HEATERS

Water vapor is a by-product of gas combustion. An unvented room heater produces approximately one (1) ounce (30 ml) of water for every 1,000 BTU's (.3KW's) of gas input per hour. Refer to page 6.

TABLE OF CONTENTS

SECTION	PAGE
IMPORTANT SAFETY INFORMATION.....	3
SAFETY INFORMATION FOR USERS OF LP-GAS	4
INTRODUCTION.....	5
SPECIFICATIONS.....	6
WATER VAPOR: A BY-PRODUCT OF UNVENTED ROOM HEATERS.....	6
PROVISIONS FOR ADEQUATE COMBUSTION & VENTILATION AIR.....	7
GAS SUPPLY.....	8
CLEARANCES.....	9
ADJUSTING AIR SHUTTER	10
LOG PLACEMENT.....	11
OPERATING GUIDELINES.....	12
LIGHTING INSTRUCTIONS.....	13
PILOT FLAME CHARACTERISTICS.....	14
MAIN BURNER FLAME CHARACTERISTICS	15
WIRING	16 - 17
MAINTENANCE.....	17
TROUBLESHOOTING	18 - 19
HOW TO ORDER REPAIR PARTS	19
PARTS LIST.....	20
PARTS VIEW.....	21
CASTING PARTS LIST	22
CASTING PARTS VIEW	23
ACCESSORY SIDE SHELVES INSTALLATION INSTRUCTIONS	24
OPTIONAL STONE INLAY INSTALLATION INSTRUCTIONS	24
OPTIONAL BLOWER INSTALLATION INSTRUCTIONS.....	25 - 27
SERVICE NOTES.....	28-30
QUICK REFERENCE	31

IMPORTANT SAFETY INFORMATION

THIS IS A HEATING APPLIANCE

DO NOT OPERATE THIS APPLIANCE WITHOUT FRONT PANEL INSTALLED.

- An unvented room heater having an input rating of more than 6,000 Btu per hour shall not be installed in a bathroom.
- An unvented room heater having an input rating of more than 10,000 Btu per hour shall not be installed in a bedroom or bathroom.
- Due to high temperatures, the appliance should be located out of traffic and away from furniture and draperies.
- Children and adults should be alerted to the hazard of high surface temperature and should stay away to avoid burns or clothing ignition.
- Young children should be carefully supervised when they are in the same room with the appliance.
- Do not place clothing or other flammable material on or near the appliance.
- Keep burner and control compartment clean.
- Installation and repair should be done by a **QUALIFIED SERVICE PERSON**. The appliance should be inspected before use and at least annually by a professional service person. More frequent cleaning may be required due to excessive lint from carpeting, bedding materials, etc. It is imperative that control compartments, burners and circulating air passageways of the appliance be kept clean.
- **WARNING: ANY CHANGE TO THIS HEATER OR ITS CONTROLS CAN BE DANGEROUS.**
Any safety screen or guard removed for servicing an appliance must be replaced prior to operating the heater.
- **WARNING: DO NOT** operate this appliance unless all components including logs, burners, and controls are in good working condition. Never operate this appliance if any log or twig is broken, or out of their intended position. Refer to the Log set placement instructions for correct log and twig positioning. Replacement components are available through your local dealer as indicated in the How to Order Repair Parts section of the appliance manual.
- **DO** make a periodic visual check of pilot and burners. Clean and replace damaged parts.
- **DO NOT** use this room heater if any part has been under water. Immediately call a qualified service technician to inspect the room heater and to replace any part of the control system and any gas control which has been under water.
- Due to high surface temperatures, keep children, clothing and furniture away.
- Under no circumstances should any solid fuels (wood, coal, paper or cardboard etc.) be used in this appliance.
- The flow of combustion and ventilation air must not be obstructed in any way.
- **WARNING:** Failure to keep the primary air opening(s) of the burner(s) clean may result in sooting and property damage.
- Keep appliance area clear and free from combustible materials, gasoline and other flammable vapors and liquids.
- **WARNING:** Do not use a blower insert, heat exchanger insert or other accessory not approved for use with heater.

WARNING

When used without adequate combustion and ventilation air, heater may give off **CARBON MONOXIDE**, an odorless, poisonous gas.

Do not install heater until all necessary provisions are made for combustion and ventilation air. Consult the written instructions provided with the heater for information concerning combustion and ventilation air. In the absence of instructions, refer to the National Fuel Gas Code, ANSI Z223.1/NFPA 54, Air for Combustion and Ventilation, or applicable local codes.

This heater is equipped with a **PILOT LIGHT SAFETY SYSTEM** designed to turn off the heater if not enough fresh air is available.

DO NOT TAMPER WITH PILOT LIGHT SAFETY SYSTEM!

If heater shuts off, do not relight until you provide fresh air. If heater keeps shutting off, have it serviced. Keep burner and control compartment clean.

CARBON MONOXIDE POISONING MAY LEAD TO DEATH.

Early signs of carbon monoxide poisoning resemble the flu, with headache, dizziness and/or nausea. If you have these signs, heater may not be working properly. Get fresh air at once! Have heater serviced.

Some people — pregnant women, persons with heart or lung disease, anemia, those under the influence of alcohol, those at high altitudes — are more affected by carbon monoxide than others.

The pilot light safety system senses the depletion of oxygen at its location. If this heater is installed in a structure having a high vertical dimension, the possibility exists that the oxygen supply at the higher levels will be less than that at the heater. In this type of application, a fan to circulate the structure air will minimize this effect. The use of this fan will also improve the comfort level in the structure. When a fan is used to circulate air, it should be located so that the air flow is not directed at the burner.

SAFETY INFORMATION FOR USERS OF LP-GAS

Propane (LP-Gas) is a flammable gas which can cause fires and explosions. In its natural state, propane is odorless and colorless. You may not know all the following safety precautions which can protect both you and your family from an accident. Read them carefully now, then review them point

by point with the members of your household. Someday when there may not be a minute to lose, everyone's safety will depend on knowing exactly what to do. If, after reading the following information, you feel you still need more information, please contact your gas supplier.

LP-GAS WARNING ODOR

If a gas leak happens, you should be able to smell the gas because of the odorant put in the LP-Gas.

That's your signal to go into immediate action!

- Do not operate electric switches, light matches, use your phone. Do not do anything that could ignite the gas.
- Get everyone out of the building, vehicle, trailer, or area. Do that IMMEDIATELY.
- Close all gas tank or cylinder supply valves.
- LP-Gas is heavier than air and may settle in low areas such as basements. When you have reason to suspect a gas leak, keep out of basements and other low areas. Stay out until firefighters declare them to be safe.
- Use your neighbor's phone and call a trained LP-Gas service person and the fire department. Even though you may not continue to smell gas, do not turn on the gas again. Do not re-enter the building, vehicle, trailer, or area.
- **Finally**, let the service man and firefighters check for escaped gas. Have them air out the area before you return. Properly trained LP-Gas service people should repair the leak, then check and relight the gas appliance for you.

NO ODOR DETECTED - ODOR FADE

Some people cannot smell well. Some people cannot smell the odor of the chemical put into the gas. You must find out if you can smell the odorant in propane. Smoking can decrease your ability to smell. Being around an odor for a time can affect your sensitivity or ability to detect that odor. Sometimes other odors in the area mask the gas odor. People may not smell the gas odor or their minds are on something else. Thinking about smelling a gas odor can make it easier to smell.

The odorant in LP-gas is colorless, and it can fade under some circumstances. For example, if there is an underground leak, the movement of the gas through soil can filter the odorant. Odorants

in LP-Gas also are subject to oxidation. This fading can occur if there is rust inside the storage tank or in iron gas pipes.

The odorant in escaped gas can adsorb or absorb onto or into walls, masonry and other materials and fabrics in a room. That will take some of the odorant out of the gas, reducing its odor intensity.

LP-Gas may stratify in a closed area, and the odor intensity could vary at different levels. Since it is heavier than air, there may be more odor at lower levels. Always be sensitive to the slightest gas odor. If you detect any odor, treat it as a serious leak. Immediately go into action as instructed earlier.

SOME POINTS TO REMEMBER

- **Learn to recognize the odor of LP-gas.** Your local LP-Gas Dealer can give you a "Scratch and Sniff" pamphlet. Use it to find out what the propane odor smells like. If you suspect that your LP-Gas has a weak or abnormal odor, call your LP-Gas Dealer.
- If you are not qualified, do not light pilot lights, perform service, or make adjustments to appliances on the LP-Gas system. If you are qualified, consciously think about the odor of LP-Gas prior to and while lighting pilot lights or performing service or making adjustments.
- Sometimes a basement or a closed-up house has a musty smell that can cover up the LP-Gas odor. Do not try to light pilot lights, perform service, or make adjustments in an area where the conditions are such that you may not detect the odor if there has been a leak of LP-Gas.
- Odor fade, due to oxidation by rust or adsorption on walls of new cylinders and tanks, is possible. Therefore, people should be particularly alert and careful when new tanks or cylinders are placed in service. Odor fade can occur in new tanks, or
- reinstalled old tanks, if they are filled and allowed to set too long before refilling. Cylinders and tanks which have been out of service for a time may develop internal rust which will cause odor fade. If such conditions are suspected to exist, a periodic sniff test of the gas is advisable. **If you have any question about the gas odor, call your LP-gas dealer. A periodic sniff test of the LP-gas is a good safety measure under any condition.**
- If, at any time, you do not smell the LP-Gas odorant and you think you should, assume you have a leak. Then take the same immediate action recommended above for the occasion when you do detect the odorized LP-Gas.
- If you experience a complete "gas out," (the container is under no vapor pressure), turn the tank valve off immediately. If the container valve is left on, the container may draw in some air through openings such as pilot light orifices. If this occurs, some new internal rusting could occur. If the valve is left open, then treat the container as a new tank. Always be sure your container is under vapor pressure by turning it off at the container before it goes completely empty or having it refilled before it is completely empty.

INTRODUCTION

Always consult your local Building Department regarding regulations, codes or ordinances which apply to the installation of an unvented room heater.

This appliance may be installed in an aftermarket* permanently located, manufactured (mobile) home, where not prohibited by state or local codes.

*Aftermarket: Completion of sale, not for purpose of resale, from the manufacturer.

This appliance is only for use with the type of gas indicated on the rating plate.

Instructions to Installer

1. Installer must leave instruction manual with owner after installation.
2. Installer must have owner fill out and mail warranty card supplied with unvented room heater.
3. Installer should show owner how to start and operate unvented room heater.

This product is design certified in accordance with American National Standards Institute Z21.11.2 by Underwriters Laboratories (UL) as an Unvented Room Heater and should be installed according to these instructions.

Notice: Remove screw in valve cover. Screw is required to prevent shipping damage.

Attention: During initial use of ceramic log you will detect an odor as the ceramic log is cured.

Any alteration of the original design, installed other than as shown in these instructions or use with a type of gas not shown on the rating plate is the responsibility of the person and company making the change. Do not operate this appliance unless all components including logs, burners, and controls are in good working condition. Never operate this appliance if any log or twig is broken, or out of their intended position. Refer to Log Placement on page 11 for correct log and twig positioning.

Replacement parts are available through your local dealer as indicated in the Parts Sections on pages 19 through 23.

Warning: This appliance is equipped for (natural or propane) gas. Field conversion is not permitted.

Warning: This unit is not for use with solid fuels.

Important

All correspondence should refer to complete Model Number, Serial Number and type of gas.

Notice: During initial firing of this unit, its paint will bake out, and smoke may occur. To prevent triggering of smoke alarms, ventilate the room in which the unit is installed.

Installation in Residential Garages

Gas utilization equipment in residential garages shall be installed so that all burners and burner ignition devices are located not less than 18" (457 mm) above the floor.

Such equipment shall be located, or protected, so it is not subject to physical damage by a moving vehicle.

Preparation

This vent free gas fireplace and its components are tested and safe when installed in accordance with this Installation Manual. Report to your dealer any parts damaged in shipment, specifically check log

placement. Do not install unit with damaged, incomplete, or substitute parts. Read all instructions before starting installation and follow these instructions carefully during installation to insure maximum benefit and safety. Failure to follow them will void your warranty and may present a fire hazard.

The warranty will be voided by, and the warranter disclaims any responsibility for the following actions:

- Installation of any damaged fireplace.
- Modification of the fireplace.
- Installation other than as instructed by Empire Comfort Systems Inc.
- Improper positioning of the logs.
- Installation and/or use of any component part not manufactured or approved by manufacturer.

Qualified Installing Agency

Installation and replacement of gas piping, gas utilization equipment or accessories and repair and servicing of equipment shall be performed only by a qualified agency. The term "qualified agency" means any individual, firm, corporation or company which either in person or through a representative is engaged in and is responsible for (a) the installation or replacement of gas piping or (b) the connection, installation, repair or servicing of equipment, who is experienced in such work, familiar with all precautions required and has complied with all the requirements of the authority having jurisdiction.

State of Massachusetts: The installation must be made by a licensed plumber or gas fitter in the Commonwealth of Massachusetts.

Sellers of unvented propane or natural gas-fired supplemental room heaters shall provide to each purchaser a copy of 527 CMR 30 upon sale of the unit. In the State of Massachusetts, unvented propane or natural gas fired space heaters shall be prohibited in bedrooms and bathrooms.

The installation must conform with local codes or, in the absence of local codes, with the *National Fuel Gas Code, ANSI Z223.1/NFPA 54*.*

*Available from the American National Standards Institute, Inc., 11 West 42nd St., New York, N.Y. 10036.

Warning: ANY CHANGE TO THIS FIREPLACE OR ITS CONTROLS CAN BE DANGEROUS.

Improper installation or use of the fireplace can cause serious injury or death from fire, burns, explosions, or carbon monoxide poisoning.

Any alteration of the original design, installed other than shown in these instructions or use with a type of gas not shown on the rating plate is the responsibility of the person and company making the change.

High Altitudes

For altitudes/elevations above 2,000 feet (610 m), ratings should be reduced at the rate of 4 percent for each 1,000 feet (305 m) above sea level. Contact the manufacturer or your gas company before changing spud/orifice size.

SPECIFICATIONS

Model	VFP30CA30(B,F,M,S,W)
Input BTU/HR (KW/H) Maximum	32,000 (9.4)
BTU/HR (KW/H) Minimum	22,400 (6.6)
Height	27 3/4" (704.9 mm)
Width	28 1/16" (712.8 mm)
Depth	17 1/8" (435.0 mm)
Gas Inlet	3/8" (9.5 mm)

Accessories	
Shelf Kit - Includes both left & right shelves	
CSK-B	Porcelain Black
CSK-F	Matte Black
CSK-M	Porcelain Mahogany
CSK-S	Porcelain Sand
CSK-W	Matte Pewter

Accessories		
FRBC	Battery Operated Remote Control	
FRBTC	Battery Operated Remote Control w/Thermostat	
FRBTP	7-Day Programmable Remote	
FREC	Electric Remote Control	
FWS	Wall Switch	
TMV	Millivolt Wall Thermostat - Reed Switch	
TRW	Remote Wall Thermostat	
CIB	Automatic Blower	
Stone Inlay Replaces Standard Grill Top		
CSI-8V	Stone Inlay	Venetian Gold
CSI-9A	Stone Inlay	Adobe Frost
CSI-10M	Stone Inlay	Patina Mocha
CSI-11G	Stone Inlay	Temple Gray
CSI-12A	Stone Inlay	American Beauty

WATER VAPOR: A BY-PRODUCT OF UNVENTED ROOM HEATERS

Water vapor is a by-product of gas combustion. An unvented room heater produces approximately one (1) ounce (30 ml) of water for every 1,000 BTU's (.3KW's) of gas input per hour.

Unvented room heaters must be used as supplemental heat (a room) rather than a primary heat source (an entire house). In most supplemental heat applications, the water vapor does not create a problem. In most applications, the water vapor enhances the low humidity atmosphere experienced during cold weather.

The following Steps will help insure that water vapor does not become a problem.

1. Be sure the heater is sized properly for the application, including ample combustion air and circulation air.
2. If high humidity is experienced, a dehumidifier may be used to help lower the water vapor content of the air.
3. Do not use an unvented room heater as the primary heat source (an entire house).

PROVISIONS FOR ADEQUATE COMBUSTION & VENTILATION AIR

This heater shall not be installed in a confined space or unusually tight construction unless provisions are provided for adequate combustion and ventilation air.

The *National Fuel Gas Code, ANSI Z223.1* defines a confined space as a space whose volume is less than 50 cubic feet per 1,000 Btu per hour (4.8 m³ per kw) of the aggregate input rating of all appliances installed in that space and an unconfined space as a space whose volume is not less than 50 cubic feet per 1,000 Btu per hour (4.8 m³ per kw) of the aggregate input rating of all appliances installed in that space. Rooms communicating directly with the space in which the appliances are installed, through openings not furnished with doors, are considered a part of the unconfined space.

The following example is for determining the volume of a typical area in which the VFP30 may be located and for determining if this area fits the definition of an unconfined space.

The maximum input of the VFP30 is 32,000 Btu per hour. Based on the 50 cubic feet per 1,000 Btu per hour formula, the **minimum** area that is an unconfined space for installation of the VFP30 is 1,600 cubic feet, 50 cubic feet x 32 = 1,600 cubic feet. To determine the cubic feet of the area in which the VFP30 is to be installed, measure the length, width and height of the area. Example: The area measures 17 feet in length, 12 feet in width and 8 feet in height, the area is 1,632 cubic feet. The VFP30 can be installed in this unconfined space with no requirement to provide additional combustion and ventilation air.

Warning: If the area in which the heater may be operated is smaller than that defined as an unconfined space or if the building is of unusually tight construction, provide adequate combustion and ventilation air by one of the methods described in the *National Fuel Gas Code, ANSI Z223.1/NFPA 54, Air for Combustion and Ventilation*, or applicable local codes.

Unusually Tight Construction

The air that leaks around doors and windows may provide enough fresh air for combustion and ventilation. However, in buildings of unusually tight construction, you must provide additional fresh air.

Unusually tight construction is defined as construction where:

- a. Walls and ceilings exposed to the outside atmosphere have a continuous water vapor retarder with a rating of one perm or less with openings gasketed or sealed, and
- b. Weather-stripping has been added on openable windows and doors, and
- c. Caulking or sealants are applied to areas such as joints around window and door frames, between sole plates and floors, between wall-ceiling joints, between wall panels, at penetrations for plumbing, electrical, and gas lines, and at other openings.

If the VFP30 heater is installed in a building of unusually tight construction, adequate air for combustion, ventilation and dilution of flue gases shall be provided in accordance with ANSI Z223.1/NFPA54.

GAS SUPPLY

Check all local codes for requirements, especially for the size and type of gas supply line required.

Recommended Gas Pipe Diameter

Pipe Length	Schedule 40 Pipe Inside Diameter		Tubing, Type L Outside Diameter	
	Nat.	L.P.	Nat.	L.P.
0-10 feet 0-3 meters	1/2"	3/8"	1/2"	3/8"
	12.7 mm	9.5 mm	12.7 mm	9.5 mm
10-40 feet 4-12 meters	1/2"	1/2"	5/8"	1/2"
	12.7 mm	12.7 mm	15.9 mm	12.7 mm
40-100 feet 13-30 meters	1/2"	1/2"	3/4"	1/2"
	12.7 mm	12.7 mm	19 mm	12.7 mm
100-150 feet 31-46 meters	3/4"	1/2"	7/8"	3/4"
	19 mm	12.7 mm	22.2 mm	19 mm

Note: Never use plastic pipe. Check to confirm whether your local codes allow copper tubing or galvanized.

Note: Since some municipalities have additional local codes, it is always best to consult your local authority and installation code.

Installing a New Main Gas Cock

Each appliance should have its own manual gas cock.

A manual main gas cock should be located in the vicinity of the unit. Where none exists, or where its size or location is not adequate, contact your local authorized installer for installation or relocation.

Compounds used on threaded joints of gas piping shall be resistant to the action of liquefied petroleum gases. The gas lines must be checked for leaks by the installer. This should be done with a soap solution watching for bubbles on all exposed connections, and if unexposed, a pressure test should be made.

Never use an exposed flame to check for leaks. Appliance must be disconnected from piping at inlet of control valve and pipe capped or plugged for pressure test. Never pressure test with appliance connected; control valve will sustain damage!

A gas valve and ground joint union should be installed in the gas line upstream of the gas control to aid in servicing. It is required by the National Fuel Gas Code that a drip line be installed near the gas inlet. This should consist of a vertical length of pipe tee connected into the gas line that is capped on the bottom in which condensation and foreign particles may collect.

The use of the following gas connectors is recommended:

- ANS Z21.24 Appliance Connectors of Corrugated Metal Tubing and Fittings
- ANS Z21.45 Assembled Flexible Appliance Connectors of Other Than All-Metal Construction

The above connectors may be used if acceptable by the authority having jurisdiction. The state of Massachusetts requires that a flexible appliance connector cannot exceed three feet in length.

FLEXIBLE GAS LINE CONNECTION

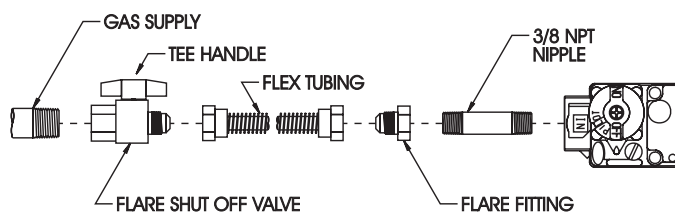

RIGID GAS LINE CONNECTION

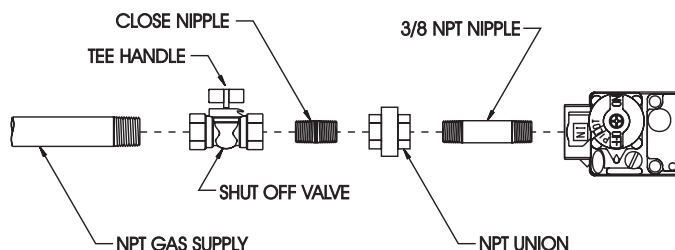

Figure 1

Pressure Testing of the Gas Supply System

1. To check the inlet pressure to the gas valve, a 1/8" (3 mm) N.P.T. plugged tapping, accessible for test gauge connection, must be placed immediately upstream of the gas supply connection to the appliance.
2. The appliance and its individual shutoff valve must be disconnected from the gas supply piping system during any pressure testing of that system at test pressures in excess of 1/2 psig (3.5 kPa).
3. The appliance must be isolated from the gas supply piping system by closing its individual manual shutoff valve during any pressure testing of the gas supply piping system at test pressures equal to or less than 1/2 psig (3.5 kPa).

Attention! If one of the above procedures results in pressures in excess of 1/2 psig (14" w.c.) (3.5 kPa) on the appliance gas valve, it will result in a hazardous condition.

Checking Manifold Pressure

Natural gas will have a manifold pressure of approximately 3.5" w.c. (.871 kPa) for maximum input or 1.7" w.c. (.423 kPa) for minimum input at the pressure regulator outlet with the inlet pressure to the pressure regulator from a minimum of 4.5" w.c. (1.245 kPa) for the purpose of input adjustment to a maximum of 10.5" w.c. (2.614 kPa). Propane gas will have a manifold pressure approximately 10.0" w.c. (2.49 kPa) for maximum input or 6.3" w.c. (1.568 kPa) for minimum input at the pressure regulator outlet with the inlet pressure to the pressure regulator from a minimum of 11.0" w.c. (2.739 kPa) for the purpose of input adjustment to a maximum of 13.0" w.c. (3.237 kPa).

NOTE: The gas control is equipped with a captured screw type pressure test point, therefore it is not necessary to provide a 1/8" test point up stream of the control.

A test gauge connection is located downstream of the gas appliance pressure regulator for measuring gas pressure. The connection is a 1/8 inch (3 mm) N.P.T. plugged tapping.

CLEARANCES

Clearances (Figures 2, 3, and 4)

When facing the front of the appliance the following minimum clearances to combustible construction must be maintained.

Top of appliance (ceiling)	36 inches
Rear Wall	2 inches
Side Wall	6 inches
Heater Corners (45° angle) to Wall	4 inches
Floor	0 inches

Provide adequate clearances around air openings.

Adequate accessibility clearances for purposes of servicing and proper operation must be provided.

Installation on Rugs and Tile

This appliance must be installed on a flat, solid, continuous surface (e.g. wood, metal, concrete). This may be the floor, or it may be raised up on a platform to enhance its visual impact. The appliance may be installed on carpeting, vinyl, wood flooring or other combustible material.

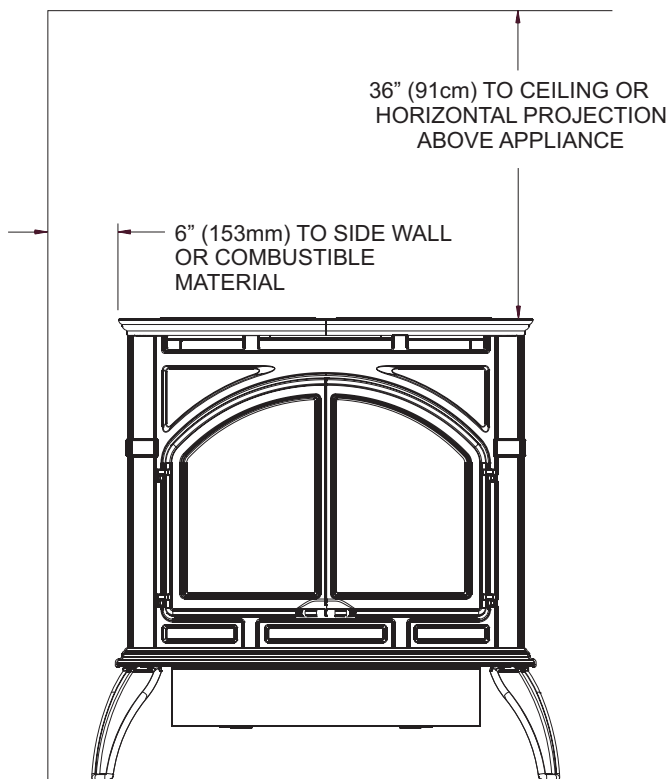

Figure 2

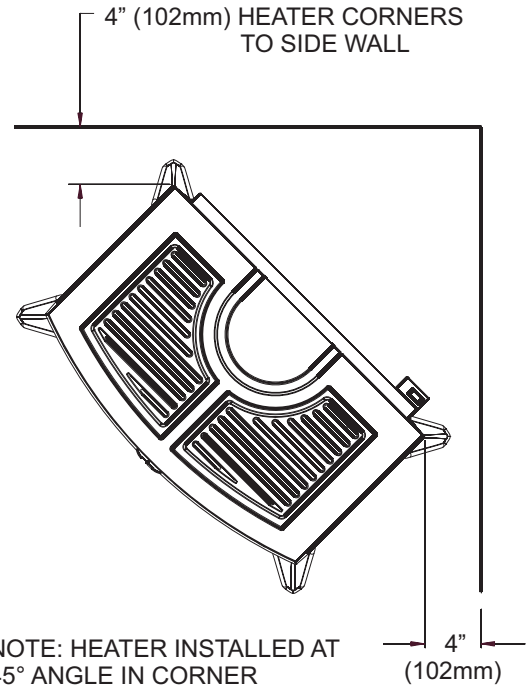

Figure 3

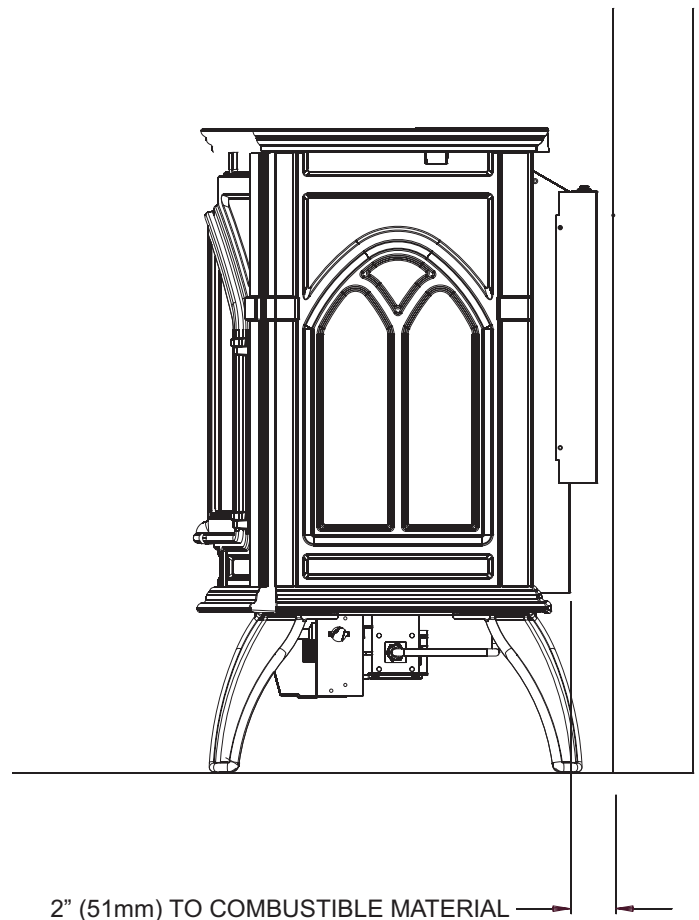

Figure 4

ADJUSTING AIR SHUTTER

The air shutter has been factory set to the optimum performance level for this appliance. LP air shutter is not adjustable.

1. Remove cast iron top and carefully set aside.
2. Remove cast iron front and carefully set aside.
3. Remove screen door by removing two (2) screws. See Figure 5.
4. Carefully remove logs and set aside.
5. Remove the log shelf by removing the two (2) screws securing the log shelf to the rear wall. See Figure 6.
6. Remove the burner by removing the two (2) screws at the front of the burner as shown in Figure 7.
7. Carefully remove the burner by lifting straight up.
8. Loosen the two (2) nuts on the air shutter shown in Figure 8 to adjust the air shutter. Figure 8 call-out demonstrates the proper locations for Natural Gas. LP utilizes a fixed air shutter.
9. Tighten the two (2) nuts back down locking the air shutter in place. Be sure that the air shutter is the same distance from the burner orifice on both sides of the air shutter for proper burner fit up.
10. Carefully replace the burner by dropping it down over the orifice holder and air shutter lining up the front mounting holes with the holes on the firebox.
11. Replace the two (2) screws at the front of the burner shown in Figure 7.
12. Replace the log shelf by replacing the two (2) screws removed in Step 4 securing the log shelf to the rear wall.
13. Replace Logs. See Page 11.
14. Replace the screen door by replacing the two (2) screws removed in Step 3.
15. Replace cast iron front.
16. Replace cast iron top.

Note: Be sure air shutter is adjusted and tightened evenly to ensure proper fit, failure to evenly adjust air shutter can cause improper combustion. Only a certified technician should adjust the air shutter.

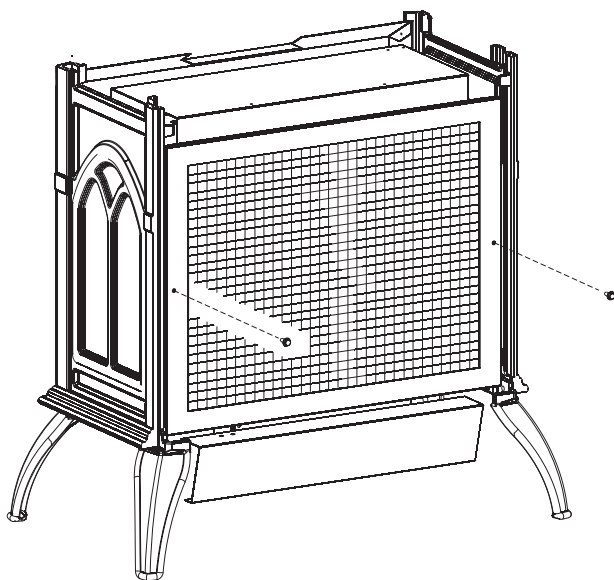

Figure 5

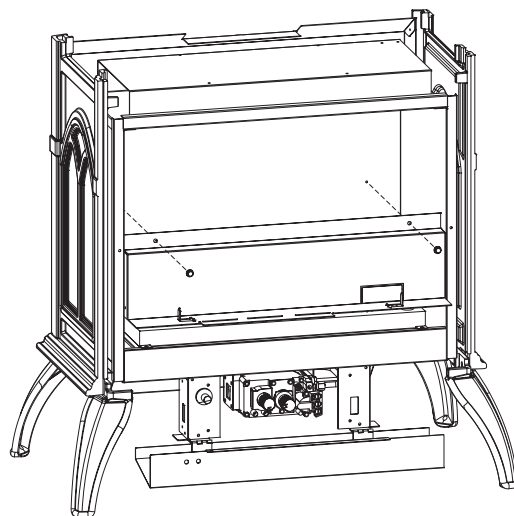

Figure 6

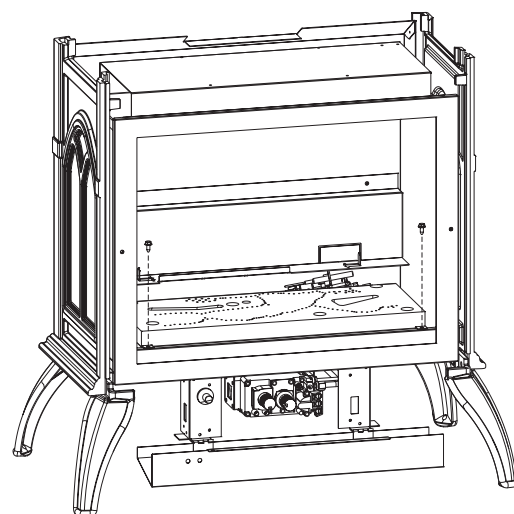

Figure 7

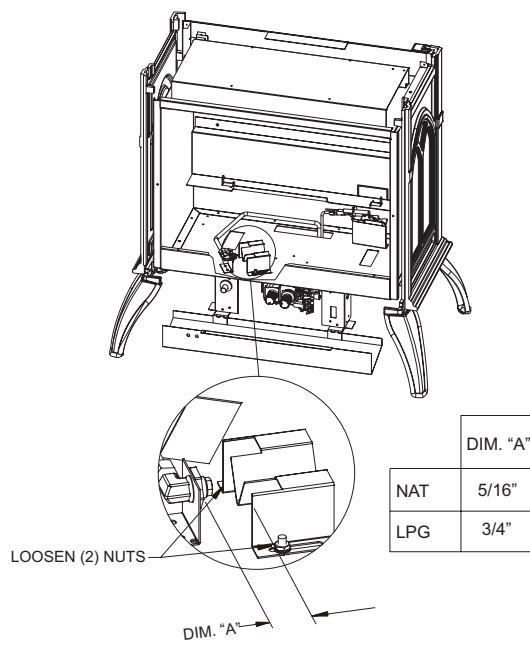

Figure 8

LOG PLACEMENT

1. Remove cast iron top and carefully set aside.
2. Remove cast iron front and carefully set aside.
3. Remove two (2) screws from screen frame assembly.
4. Carefully remove screen frame assembly and set aside.
5. Remove logs from shipping crate. Remove all protective packaging from logs and interior of firebox.
6. Place rear log onto two (2) pins on rear log support.
7. Place center left front log onto flat portion of left side of burner.
8. Place right front log onto flat portion on right side of burner. Toe of right front log should rest in groove on ember bed twig.
9. Place front left log chunk onto flat portion of burner on left front side.
10. Place left twig onto left side pin on rear log with toe resting on the groove in the left front log.
11. Place right twig onto right side pin on rear log with toe resting all the way to the right on the right front log.
12. Align and place screen frame assembly over outer frame of firebox.
13. Attach two (2) screws removed in step 3.
14. Log placement is completed.
15. Install cast iron front.
16. Install cast iron top.

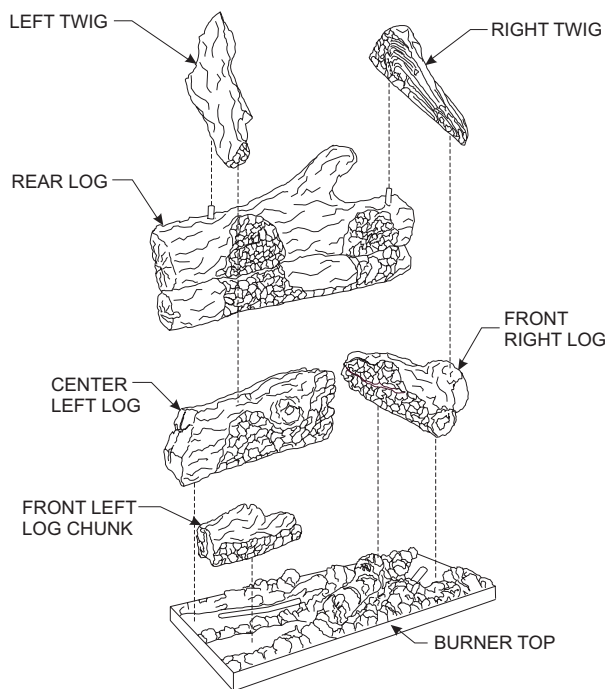
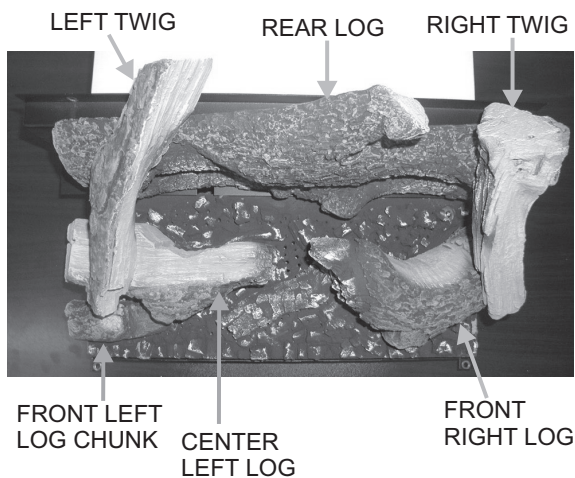

Figure 9

Refer to Figure 9 for the following warning.

Warning: Failure to position the parts in accordance with this diagram or failure to use only parts specifically approved with this appliance may result in property damage or personal injury.



Log Placement - Top View

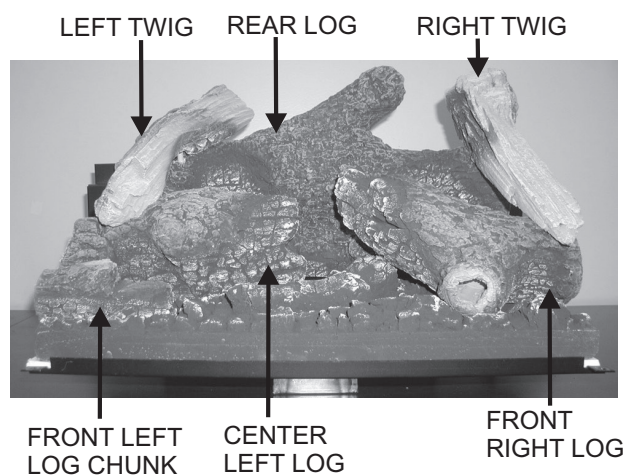

Log Placement - Front View

OPERATING GUIDELINES

Before operating this heater, please review the safety warnings pages at the beginning of this manual and those precautions and warnings listed below.

1. Know what type of ignition system this model has (standing pilot) and follow the applicable SAFETY and LIGHTING instructions.
2. Check to ensure there are no gas leaks. If you are unsure, turn gas off to the heater and call a service person or your gas utility.

CAUTION: Clothing or other flammable material should not be placed on or near the appliance.

WARNING: Children and adults should be alerted to the hazard of high surface temperature and should stay away to avoid burns or clothing ignition. Young children should be carefully supervised when they are in the same room as the appliance.

3. Tampering is DANGEROUS and voids all warranties. Any component that is found to be faulty, must be replaced with an approved component.

Initial Lighting (Figure 10)

Upon completing the gas line or turning the gas valve "ON" after it has been in the "OFF" position, a small amount of air will be in the lines. When first lighting the appliance, it will take a few minutes for the lines to purge themselves of this air. Once the purging is complete, the appliance will light and operate satisfactorily.

Subsequent lightings of the appliance will not require such purging if the gas valve is not turned to "OFF."

Standing Pilot Operation

1. Follow the SAFETY and LIGHTING INSTRUCTIONS for standing pilot controls found in this manual and on labels found attached to the appliance.

CAUTION: During the initial purging and subsequent lightings, never allow the gas valve control knob to remain depressed in the "pilot" position without pushing the piezo ignitor button at least once every second.

2. During the heating season, leave the control valve knob in the "ON" position. This will allow the pilot flame to remain lit.

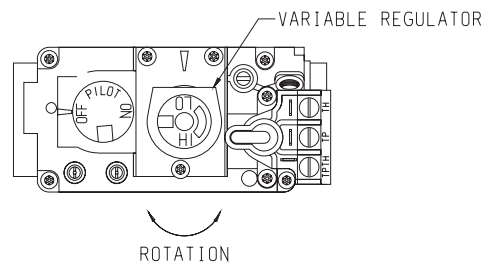

Figure 10

Turn the burner flame on or off

with the appliance REMOTE/OFF/ON rocker switch, wall switch, remote control kits or 750 millivolt wall thermostat.

NOTE: The gas control valve allows you to increase or decrease the height of the main burner flame. The control valve has a pressure regulator with a knob as shown in Figure 10. Rotate the knob clockwise to "HI" to increase the flame height and counterclockwise to "LO" to decrease the flame height.

3. When the heating season is over, turn the REMOTE/OFF/ON switch to "OFF" and the control valve to "OFF". The system, including the pilot light, will be shut down.

Maximum and Minimum Input

The gas valve on the appliance allows the input to adjust between a maximum input of 32,000 Btuh to a minimum input of 22,400 Btuh. Please be advised, the maximum input provides the greatest amount of yellow flame and ember glow on the log set. The minimum input substantially decreases the yellow flame and ember glow on the log set.

LIGHTING INSTRUCTIONS

FOR YOUR SAFETY READ BEFORE LIGHTING

WARNING: IF YOU DO NOT FOLLOW THESE INSTRUCTIONS EXACTLY, A FIRE OR EXPLOSION MAY RESULT CAUSING PROPERTY DAMAGE, PERSONAL INJURY OR LOSS OF LIFE.

- A. This appliance has a pilot which must be lighted by hand. When lighting the pilot, follow these instructions exactly.
 - B. BEFORE LIGHTING smell all around the appliance area for gas. Be sure to smell next to the floor because some gas is heavier than air and will settle on the floor.
WHAT TO DO IF YOU SMELL GAS
 - Do not try to light any appliance
 - Do not touch any electrical switch; do not use any phone in your building
 - Immediately call your gas supplier from a neighbor's phone. Follow the gas supplier's instructions.
 - C. Use only your hand to push in or turn the gas control knob. Never use tools. If the knob will not push in or turn by hand, don't try to repair it, call a qualified service technician. Force or attempted repair may result in a fire or explosion.
 - D. Do not use this appliance if any part has been under water. Immediately call a qualified service technician to inspect the appliance and to replace any part of the control system and any gas control which has been under water.
- If you can not reach your gas supplier, call the fire department.

LIGHTING INSTRUCTIONS

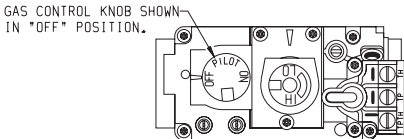
1. STOP! Read the safety information above.
2. Set the thermostat to lowest setting.
3. Turn off all electric power to the appliance (if applicable).
4. Lower valve cover.
5. Push in gas control knob slightly and turn clockwise to "OFF."

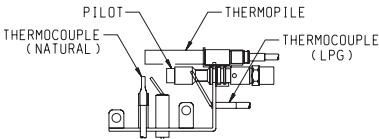
NOTE: Knob cannot be turned from "PILOT" to "OFF" unless knob is pushed in slightly. Do not force.
6. Wait ten (10) minutes to clear out any gas. Then smell for gas, including near the floor. If you smell gas, STOP! Follow "B" in the safety information above on this plate. If you do not smell gas, go to the next Step.

7. Find pilot - The pilot is attached to the main burner behind the front log.
8. Turn gas control knob counterclockwise to "PILOT."
9. Push in control knob all the way and hold in. Repeatedly push the Piezo Ignitor Button until the pilot is lit. Continue to hold the control knob in for about one (1) minute after the pilot is lit. Release knob and it will pop back up. Pilot should remain lit. If it goes out, repeat Steps 5 through 9.
 - If knob does not pop up when released, stop and immediately call a qualified service technician or gas supplier.
 - If the pilot will not stay lit after several tries, turn the gas control knob to "OFF" and call your service technician or gas supplier.
10. Attention! Gas control has an INTERLOCK latching device. When the pilot is initially lit and the safety magnet is energized (pilot stays "on"), the INTERLOCK latching device becomes operative. If the gas control is turned to "OFF" position or gas flow to the appliance shut off, the pilot cannot be relighted until the safety magnet is de-energized (approximately 60 seconds). There will be an audible "click" when the safety magnet in the gas control is de-energized. Pilot can now be relighted. Repeat Steps 5 thru 9.
11. Turn gas control knob counterclockwise to "ON."
12. Raise valve cover.
13. Turn on all electric power to the appliance (if applicable).
14. Set thermostat to desired setting.

TO TURN OFF GAS APPLIANCE

1. Set the thermostat to lowest setting.
2. Turn off all electric power to the appliance if service is to be performed (if applicable).
3. Lower valve cover.
4. Push in gas control knob slightly and turn clockwise to "OFF."
5. Raise valve cover.

PILOT FLAME CHARACTERISTICS

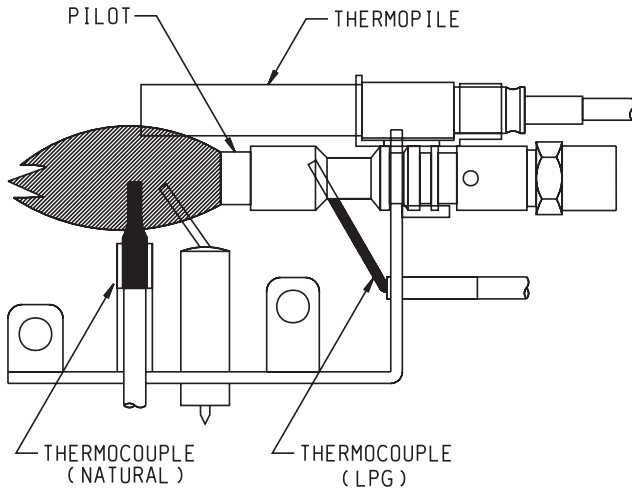
Figure 11 shows a correct pilot flame pattern. The correct flame will be blue and will extend beyond the thermocouple and thermopile. The flame will surround the thermocouple and thermopile just below the tip. A slight yellow flame may occur where the pilot flame and main burner flame meet. Figure 12 shows an incorrect pilot flame pattern. The incorrect pilot flame is not touching the thermocouple or thermopile. This will cause the thermocouple or thermopile to cool. When the thermocouple cools, the heater will shut down.



Correct Pilot Flame Pattern

Figure 11

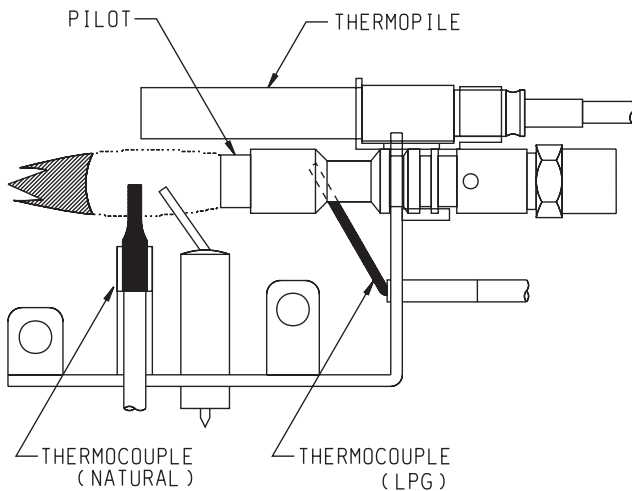

Incorrect Pilot Flame Pattern

Figure 12

If pilot flame pattern is incorrect, as shown in Figure 12

- See Troubleshooting, pages 18 and 19.

Cleaning and Maintenance/Pilot

Oxygen Depletion Sensor Pilot (Figure 13)

When the pilot has a large yellow tip flame, clean the Oxygen Depletion Sensor as follows:

1. Clean the ODS pilot by loosening nut B from the pilot tubing. When this procedure is required, grasp nut A with an open wrench.
2. Blow air pressure through the holes indicated by the arrows. This will blow out foreign materials such as dust, lint and spider webs. Tighten nut B also by grasping nut A.

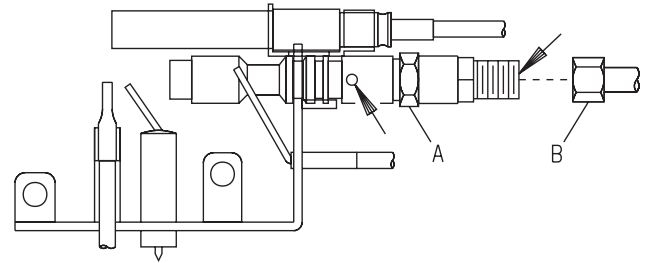

Figure 13

MAIN BURNER FLAME CHARACTERISTICS

Figure 14 shows a correct main burner flame pattern. Figure 15 shows an incorrect main burner flame pattern.

If main burner flame pattern is incorrect, as shown in Figure 15:

- See Troubleshooting, pages 18 and 19.

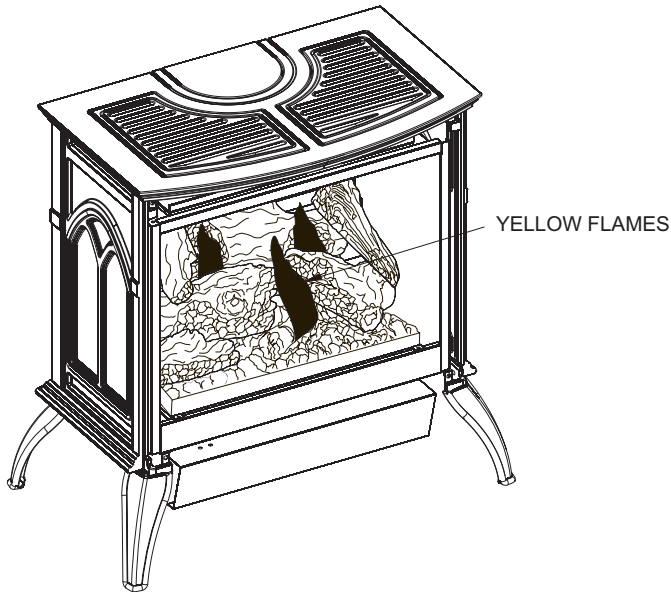

Correct Main Burner Flame
Figure 14

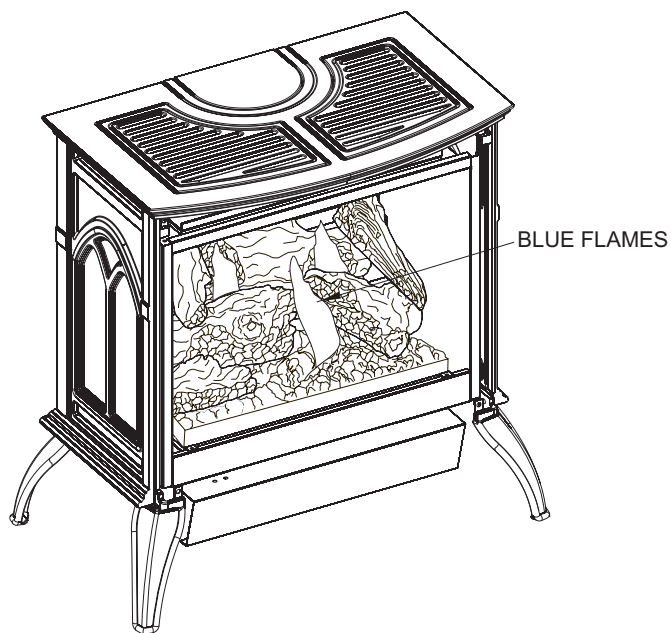

Incorrect Main Burner Flame
Figure 15

Cleaning and Maintenance / Main Burner

Warning: Turn off heater and let cool before cleaning.

After use, cleaning of the main burner may be required for the proper flame. The main burner may be cleaned by applying air pressure to the ports on the main burner.

Cleaning the Log Set and Firebox

CAUTION: Do not handle these logs with your bare hands. Always wear gloves to prevent skin irritation.

During the annual inspection and maintenance appointment, the service person should clean dust, lint, and any light accumulation from the logs and the firebox area. An extra-soft brush should be used on the logs and burner as they are extremely fragile; a vacuum cleaner may be used on the firebox. If at any time the logs cannot be removed or installed without forcing, the cause must be found. The logs must never be forced.

CAUTION: The ceramic logs are durable when handled and installed properly. However, they are delicate and may be damaged easily if not handled with care. Handling damage to the ceramic logs is not covered by warranty.

DO NOT HANDLE LOGS WHILE THEY ARE HOT. ALLOW PLENTY OF TIME FOR THE APPLIANCE TO COOL COMPLETELY BEFORE HANDLING.

PLEASE NOTE

It is normal for appliances fabricated of steel to give off some expansion and/or contraction noises during the start up or cool down cycle. Similar noises are found with your furnace heat exchanger or car engine.

WIRING

ON/OFF/REMOTE Switch

This product is equipped with an ON/OFF/REMOTE switch which is located on the wire channel. A wire harness is attached to the ON/OFF/REMOTE switch. The red, black and green (wires) female push-ons attach to the ON/OFF/REMOTE switch. At the opposite end of the wire harness, the black and green (wires) female push-ons attach to the gas valve. An additional green wire and the red wire, which are stripped and bare, will attach to the 750 millivolt wall thermostat accessory, or, to one of the other accessories that can be purchased for use with your log set.

Operation of ON/OFF/REMOTE Switch with no Accessories

To ignite main burner, turn the control knob on the gas valve from the PILOT position to the ON position. Turn the ON/OFF/REMOTE switch from the OFF position to the ON position. The additional green wire and red wire, which are stripped and bare are not used.

Operation of ON/OFF/REMOTE Switch with Accessories 750 Millivolt Wall Thermostat

Connect the green and red, stripped and bare, wires on the ON/OFF/REMOTE switch wire harness to the wall thermostat. Turn the ON/OFF/REMOTE switch on the wire channel to the REMOTE position. Set the wall thermostat to the desired temperature.

It is important to use wire of a gauge proper for the length of the wire:

RECOMMENDED WIRE GAUGES

Maximum Length	Wire Gauge
1' to 10'	18
10' to 25'	16
25' to 35'	14

Wall Switch, FWS-1

Connect the green and red, stripped and bare, wires on the ON/OFF/REMOTE switch wire harness to the wall switch. Turn the ON/OFF/REMOTE switch on the wire channel to the REMOTE position. Pivot the rocker switch on the FWS-1 to the ON position.

Battery Operated Remote Control, FRBC, FRBTP, TRW, and FRBTC

Connect the green and red, stripped and bare, wires on the ON/OFF/REMOTE switch wire harness to the remote receiver that is a component in the FRBC and FRBTC. Turn the ON/OFF/REMOTE switch on the wire channel to the REMOTE position. Follow instructions in the FRBC and FRBTC to complete installation.

Note: If batteries fail in FRBC or FRBTC, and immediate heat is desired, turn the ON/OFF/REMOTE switch on wire channel from the REMOTE position to the ON position.

Electric (120 volt) Operated Remote Control, FREC

Connect the green and red, stripped and bare, wires on the ON/OFF/REMOTE switch wire harness to the wires on remote receiver that is a component in the FREC. Turn the ON/OFF/REMOTE switch on the wire channel to the REMOTE position. Follow instructions in the FREC to complete installation.

Note: If electric (120 volt) fails in FREC, and immediate heat is desired, turn the ON/OFF/REMOTE switch on wire channel from the REMOTE position to the ON position.

Wiring of ON/OFF/REMOTE Switch with 750 Millivolt Wall Thermostat Accessory and Another Accessory

Connect the green and red, stripped and bare, wires on the ON/OFF/REMOTE switch wire harness to the 750 millivolt wall thermostat AND to the remote receiver that is a component in the FRBC, FREC OR to the FWS, wall switch.

1. Connect (1) wire from the 750 millivolt wall thermostat and (1) wire from appropriate accessory to the GREEN, stripped and bare wire from the ON/OFF/REMOTE wire harness.
2. Connect (1) wire from the 750 millivolt wall thermostat and (1) wire from appropriate accessory to the RED, stripped and bare wire from the ON/OFF/REMOTE wire harness.

Note: When the appliance is in the MANUAL mode and the batteries fail in the FRBC or if the electric (120 volt) fails in the FREC, and immediate heat is desired, turn the ON/OFF/REMOTE switch on wire channel from the REMOTE position to the ON position.

Manual Operation

1. Turn ON/OFF/REMOTE switch on wire channel to REMOTE position.
2. Turn wall thermostat OFF.
3. Turn accessory, FRBC, FREC, FRBTP, TRW or FWS, ON. Appliance is now in the manual mode. You must turn the appliance ON or OFF with appropriate accessory.

Wall Thermostat Operation

1. Turn the ON/OFF/REMOTE switch on wire channel to REMOTE position.
2. Turn accessory, FRBC, FREC or FWS, OFF.
3. Turn wall thermostat ON and set appropriate temperature. Wall thermostat will cycle the appliance ON and OFF.

Installation of Remote Receiver

(Figure 16)

1. Attach, from left to right, the slide-on cover plate onto the remote receiver. **ON** will be to the top and **OFF** will be to the bottom on the slide-on cover plate.
2. Push the receiver slide button onto the receiver slide switch. Reverse installation of the slide button if it is off center.
3. Attach Velcro loop on the left side of the valve cover support.
4. Attach Velcro hook onto remote receiver. The word **TOP** on the remote receiver should be to the top when installed onto valve cover support.
5. Attach Velcro hook on remote receiver onto Velcro loop on valve cover support.

Refer to remote control installation and operating instructions for more details on remote control.

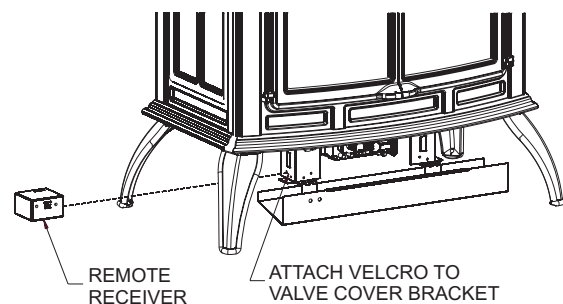

Figure 16

WIRING (continued)

Wiring Diagram

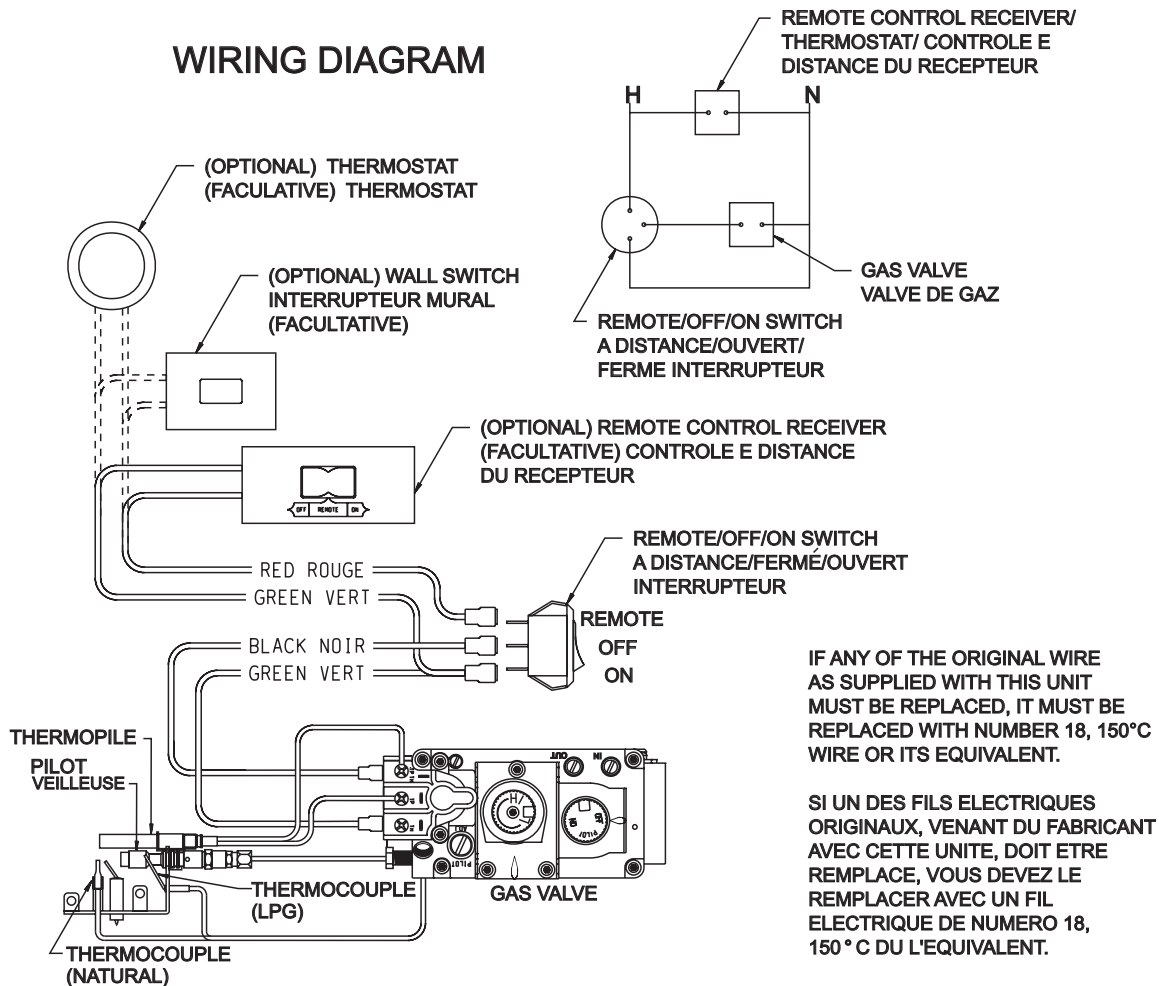

Figure 17

MAINTENANCE

IMPORTANT: Turn off gas before servicing appliance. It is recommended that a qualified service technician perform these check-ups at the beginning of each heating season.

- Clean Burner and Control Compartment
Keep the control compartment, logs and burner area surrounding the logs clean by vacuuming or brushing at least twice a year.

Cleaning Procedure (Figure 18)

1. Turn off pilot light at gas valve.
2. Remove screen front. [(2) 10 x 1/2" screws]
3. Vacuum burner compartment especially around orifice/primary air openings. See Page 10, Adjusting Air Shutter.
4. Replace screen front. [(2) 10 x 1/2" screws]
5. Ignite pilot. (See Lighting Instructions, page 13)
6. Operate the main burner and visually check to make sure the flame pattern appears similar to the pictorial illustration shown for proper main burner flame pattern, Figure 14. If it appears abnormal call a service person.

Verify proper operation after servicing.

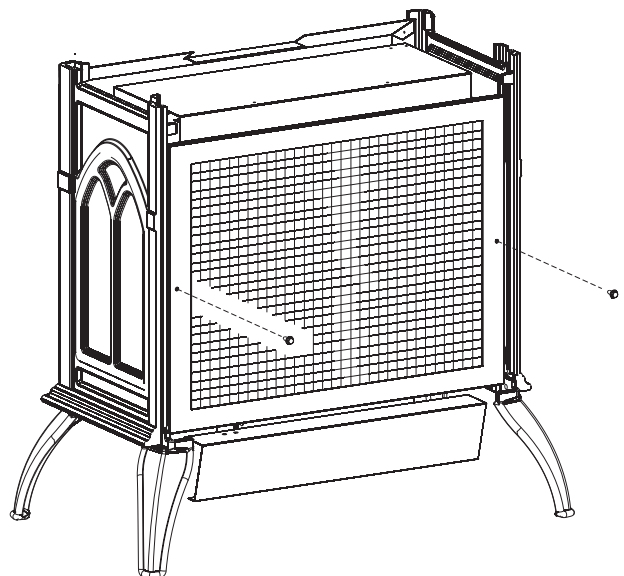

Figure 18

TROUBLESHOOTING

SYMPTOMS - POSSIBLE CAUSES AND CORRECTIONS

IMPORTANT: Operating heater where impurities in air exist may create odors. Cleaning supplies, paint, paint remover, cigarette smoke, cements and glues, new carpet or textiles, etc., create fumes. These fumes may mix with combustion air and create odors.

- 1. When ignitor button is pressed, there is no spark at ODS/pilot.**
 - a. Ignitor electrode positioned wrong - Replace ignitor.
 - b. Ignitor electrode broken - Replace ignitor.
 - c. Ignitor electrode not connected to ignitor cable - Reconnect ignitor cable.
 - d. Ignitor cable pinched or wet - Free ignitor cable if pinched by any metal or tubing. Keep ignitor cable dry.
 - e. Broken ignitor cable - Replace ignitor cable.
 - f. Bad piezo ignitor - Replace piezo ignitor.
- 2. When ignitor button is pressed, there is spark at ODS/pilot, but no ignition.**
 - a. Gas supply turned off or manual shutoff valve closed - Turn on gas supply or open manual shutoff valve.
 - b. Control knob not in PILOT position - Turn gas control knob to PILOT position.
 - c. Control knob not pressed in while in PILOT position - Press in control knob while in PILOT position.
 - d. Air in gas lines when installed - Continue holding down control knob. Repeat igniting operation until air is removed.
 - e. Depleted gas supply - Contact local gas company.
 - f. ODS/pilot is clogged - Clean ODS/pilot or replace ODS/pilot assembly.
 - g. Gas regulator setting is not correct - Replace gas regulator.
- 3. ODS/pilot lights but flame goes out when control knob is released.**
 - a. Control knob not fully pressed in - Press in control knob fully.
 - b. Control knob not pressed in long enough - After ODS/pilot lights, keep control knob pressed in 30 seconds.
 - c. Safety interlock system has been triggered (thermostat models only) - Wait one minute for safety interlock system to reset. Repeat ignition operation.
 - d. Manual Shutoff valve not fully open - Fully open manual shutoff valve.
 - e. Thermocouple connection loose at control valve - Hand tighten until snug, then tighten 1/4 turn more.
 - f. Pilot flame not touching thermocouple, which allows thermocouple to cool, causing pilot flame to go out. This problem could be caused by either **1) low gas pressure** - Contact local gas company or **2) dirty or partially clogged ODS/pilot** - Clean ODS/pilot or replace ODS/pilot assembly.
 - g. Thermocouple damaged - Replace thermocouple.
 - h. Control valve damaged - Replace control valve.
- 4. Main burner does not light after ODS/pilot is lit.**
 - a. Main burner orifice clogged - Clean main burner or replace main burner orifice.
 - b. Main burner orifice diameter is too small - Replace main burner orifice.
 - c. Inlet gas pressure is too low - Contact local gas company.
- 5. Pilot burning, no gas to burner, valve knob "ON", on/off switch "ON."**
 - a. "On/Off" switch, wall switch, remote control or wires defective - Check "on/off" switch and wires for proper connections. Place jumper wires across terminal at switch - if burner comes on, replace defective switch. If OK, place jumper wires across switch wires at gas valve-if burner comes on, wires are faulty or connections are bad.
 - b. Thermopile may not be generating sufficient millivolts - If the pilot flame is not close enough physically to the thermopile, clean the ODS/pilot.
 - Be sure the wire connections from the thermopile at the gas valve terminals are tight and the thermopile is fully inserted into the pilot bracket.
 - Check the thermopile with a millivolt meter. Take the reading at TH-TP & TP terminals of the gas valve. The meter should read 350 millivolts minimum, while holding the valve knob depressed in the PILOT position, with the pilot lit, and the ON/OFF switch in the OFF position. Replace the faulty thermopile if the reading is below the specified minimum.
 - With the pilot in the ON position, disconnect the thermopile leads from the valve. Take a reading at the thermopile leads. The reading should be 350 millivolts minimum. Replace the thermopile if the reading is below the minimum.
 - c. Defective valve - Turn valve knob to "ON." Place ON/OFF switch to "ON." Check with millivolt meter at thermopile terminals. Millivolt meter should read greater than 200 millivolts. If the reading is okay and the main burner does not ignite, replace the gas valve
 - d. Plugged main burner orifice - Check main burner orifice for blockage and remove.
- 6. Delayed ignition of main burner.**
 - a. Manifold pressure is too low - Contact local gas company.
 - b. Main burner orifice clogged - Clean main burner and main burner orifice.
- 7. If burning at main burner orifice occurs (a loud, roaring blow torch noise).**
 - a. You must turn off burner assembly and contact a qualified service person.
 - b. Main burner orifice is clogged or damaged - Clean main burner and main burner orifice or replace main burner orifice.
 - c. Damaged main burner - Replace damaged main burner.
 - d. Gas regulator defective - Replace gas regulator.
- 8. Yellow flame in front section of main burner during main burner combustion.**
 - a. Not enough air - Check main burner for dirt and debris. If found, clean main burner.
 - b. Gas regulator defective - replace gas regulator.

TROUBLESHOOTING (continued)

9. Slight smoke or odor during initial operation.

- a. Residues from manufacturing processes and logs curing - Problem will stop after a few hours of operation.

10. Heater produces a whistling noise when main burner is lit.

- a. Turning control knob to HI position when main burner is cold - Turn control knob to LO position and let warm up for a minute.
- b. Air in gas line - Operate main burner until air is removed from line. Have gas line checked by local gas company.
- c. Air passageways on heater blocked - Observe minimum installation clearances (see page 9).
- d. Dirty or partially clogged main burner orifice - Clean main burner and main burner orifice or replace main burner orifice.

11. Heater produces a clicking/ticking noise just after main burner is lit or shut off.

- a. Metal expanding while heating or contracting while cooling - This is common with most heaters. If noise is excessive, contact service person.

12. Heater produces unwanted odor.

- a. Heater burning vapors from paint, hair spray, glues, cleaners, chemicals, new carpet, etc. - Open window to ventilate room. Stop using odor causing products while heater is operating.
- b. Low fuel supply - Refill supply tank.
- c. Gas leak - Locate and correct all leaks.

13. Heater shuts off in use (ODS operates).

- a. Not enough fresh air is available - Open window and/or door for ventilation.
- b. Low line pressure - Contact local gas company.
- c. ODS/pilot is partially clogged - Clean ODS/pilot.

14. Gas odor even when control knob is in OFF position.

- a. Gas leak - Locate and correct all leaks.
- b. Control valve defective - Replace control valve.

15. Gas odor during combustion.

- a. Foreign matter between logs and main burner - remove foreign matter.
- b. Gas leak - Locate and correct all leaks.

HOW TO ORDER REPAIR PARTS

Parts can be ordered only through your service person or dealer. For best results, the service person or dealer should order parts through the distributor. Parts can be shipped directly to the service person/dealer.

All parts listed in the Parts List have a Part Number. When ordering parts, first obtain the Model Number from the name plate on your equipment. Then determine the Part Number (not the Index Number) and the Description of each part from the following appropriate illustration and list. Be sure to give all this information.

Heater Model Number _____ Heater Serial Number _____

Part Number _____ Part Description _____

Type of Gas (Propane or Natural) _____

Do not order bolts, screws, washers or nuts. They are standard hardware items and can be purchased at any local hardware store.

Shipments contingent upon strikes, fires and all causes beyond our control.

Empire Comfort Systems, Inc. Nine Eighteen Freeburg Ave. Belleville, Illinois 62222-0529

PARTS LIST

PLEASE NOTE: When ordering parts, it is very important that part number and description of part coincide.

INDEX NO.	PART NO.	DESCRIPTION
1	15484	OUTLET BAFFLE
2	24043	FIREBOX BRACE (2 REQUIRED)
3	23938	FIREBOX TOP
4	24034	FIREBOX WALLS
5	24017	REAR LOG SUPPORT
6	15567	SCREEN FRAME ASSEMBLY
7	R-3624	PILOT ASSEMBLY - NAT
7	R-3623	PILOT ASSEMBLY - LPG
8	24560	PILOT BRACKET
9	26562	BURNER ASSEMBLY
10	P-253	FITTING, ORIFICE ANGLED
11	24429	BRACKET, ORIFICE HOLDER
12	R-7572	JAMB NUT
13	P-184	ORIFICE #35 - NAT
13	P-250	ORIFICE #1.65mm - LPG
14	26561	AIR SHUTTER BRACKET
15	24041	FIREBOX BOTTOM
16	15977	VALVE BRACKET
17	24024	TUBING ASSEMBLY (VALVE TO BURNER)
18	24246	TUBING ASSEMBLY (VALVE TO PILOT) (LPG ONLY)
19	24562	TUBING ASSEMBLY (REGULATOR TO PILOT) (NAT ONLY)
20	R-7063	PILOT REGULATOR (NAT ONLY)
21	24561	TUBING ASSEMBLY (VALVE TO REGULATOR) (NAT ONLY)
22	R-2423	CONNECTOR, MALE 5/16
23	R-9368	VALVE - NAT
23	R-3625	VALVE - LP
24	R-9760	PIEZO IGNITER
25	15516	VALVE COVER ASSEMBLY
26	R-9616	LOG - FRONT LEFT CHUNK
27	R-9615	LOG - CENTER LEFT
28	R-9613	LOG - REAR
29	R-9618	LOG - LEFT TWIG
30	R-9617	LOG - RIGHT TWIG
31	R-9614	LOG - FRONT RIGHT
32	24035	REAR COVER
33	26051	WIRE CHANNEL - RIGHT
34	R-3436	REMOTE/OFF/ON SWITCH
35	26052	WIRE CHANNEL - LEFT
NOT SHOWN	R-9698	WIRE ASSEMBLY

USE ONLY MANUFACTURER'S REPLACEMENT PARTS. USE OF ANY OTHER PARTS COULD CAUSE INJURY OR DEATH.

PARTS VIEW

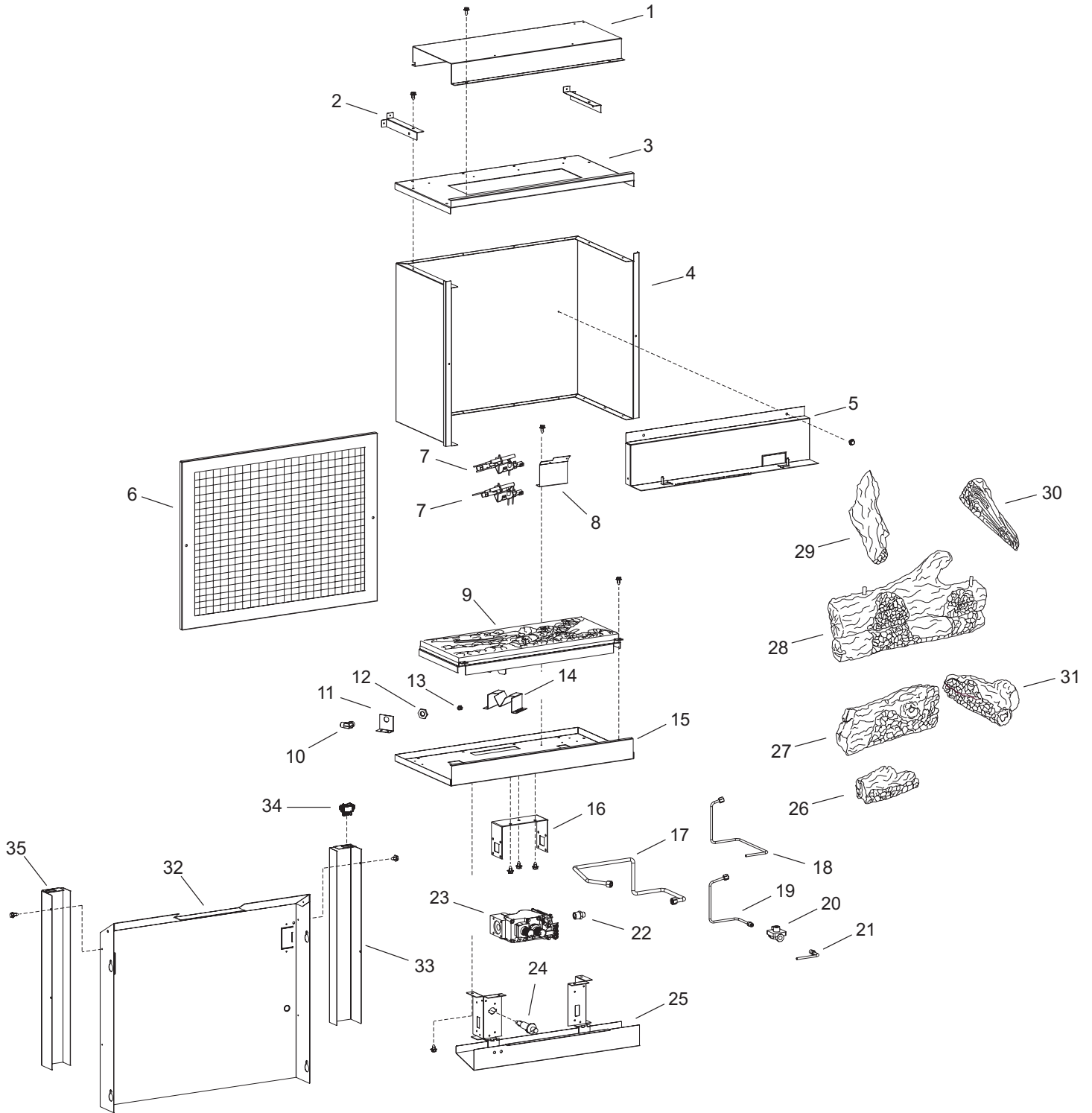

CASTING PARTS LIST

PLEASE NOTE: When ordering parts, it is very important that part number and description of part coincide.

INDEX NO.	PART NO.	DESCRIPTION
COMMON PARTS		
11	R-9671	INSERT TAB (4 REQUIRED)
NS	R-9669	HINGE PIN (4 REQUIRED)
NS	R-9670	BOLT, 1/4-20 X 1/2" (24 REQUIRED)
MATTE BLACK		
1	R-9539	VENT OPENING INSERT
2	R-9538	TOP INSERT - RIGHT
3	R-9537	TOP INSERT - LEFT
4	R-9536	CASTING TOP
5	R-9666	CASTING FRONT
6	R-9535	CASTING SIDE - RIGHT
7	R-9534	CASTING SIDE - LEFT
8	R-9668	CASTING DOOR - RIGHT
9	R-9667	CASTING DOOR - LEFT
10	24042	FIREBOX SUPPORT BRACKET (2 REQUIRED)
12	R-9533	CASTING LEG B
13	R-9532	CASTING LEG A
MATTE PEWTER		
1	R-9555	VENT OPENING INSERT
2	R-9554	TOP INSERT - RIGHT
3	R-9553	TOP INSERT - LEFT
4	R-9552	CASTING TOP
5	R-9693	CASTING FRONT
6	R-9551	CASTING SIDE - RIGHT
7	R-9550	CASTING SIDE - LEFT
8	R-9695	CASTING DOOR - RIGHT
9	R-9694	CASTING DOOR - LEFT
10	24042	FIREBOX SUPPORT BRACKET (2 REQUIRED)
12	R-9549	CASTING LEG B
13	R-9548	CASTING LEG A

INDEX NO.	PART NO.	DESCRIPTION
PORCELAIN BLACK		
1	R-9571	VENT OPENING INSERT
2	R-9570	TOP INSERT - RIGHT
3	R-9569	TOP INSERT - LEFT
4	R-9568	CASTING TOP
5	R-9681	CASTING FRONT
6	R-9567	CASTING SIDE - RIGHT
7	R-9566	CASTING SIDE - LEFT
8	R-9683	CASTING DOOR - RIGHT
9	R-9682	CASTING DOOR - LEFT
10	24191	FIREBOX SUPPORT BRACKET (2 REQUIRED)
12	R-9565	CASTING LEG B
13	R-9564	CASTING LEG A
PORCELAIN SAND		
1	R-9587	VENT OPENING INSERT
2	R-9586	TOP INSERT - RIGHT
3	R-9585	TOP INSERT - LEFT
4	R-9584	CASTING TOP
5	R-9700	CASTING FRONT
6	R-9583	CASTING SIDE - RIGHT
7	R-9582	CASTING SIDE - LEFT
8	R-9702	CASTING DOOR - RIGHT
9	R-9701	CASTING DOOR - LEFT
10	24191	FIREBOX SUPPORT BRACKET (2 REQUIRED)
12	R-9581	CASTING LEG B
13	R-9580	CASTING LEG A
PORCELAIN MAHOGANY		
1	R-9603	VENT OPENING INSERT
2	R-9602	TOP INSERT - RIGHT
3	R-9601	TOP INSERT - LEFT
4	R-9600	CASTING TOP
5	R-9707	CASTING FRONT
6	R-9599	CASTING SIDE - RIGHT
7	R-9598	CASTING SIDE - LEFT
8	R-9709	CASTING DOOR - RIGHT
9	R-9708	CASTING DOOR - LEFT
10	24191	FIREBOX SUPPORT BRACKET (2 REQUIRED)
12	R-9597	CASTING LEG B
13	R-9596	CASTING LEG A

USE ONLY MANUFACTURER'S REPLACEMENT PARTS. USE OF ANY OTHER PARTS COULD CAUSE INJURY OR DEATH.

CASTING PARTS VIEW

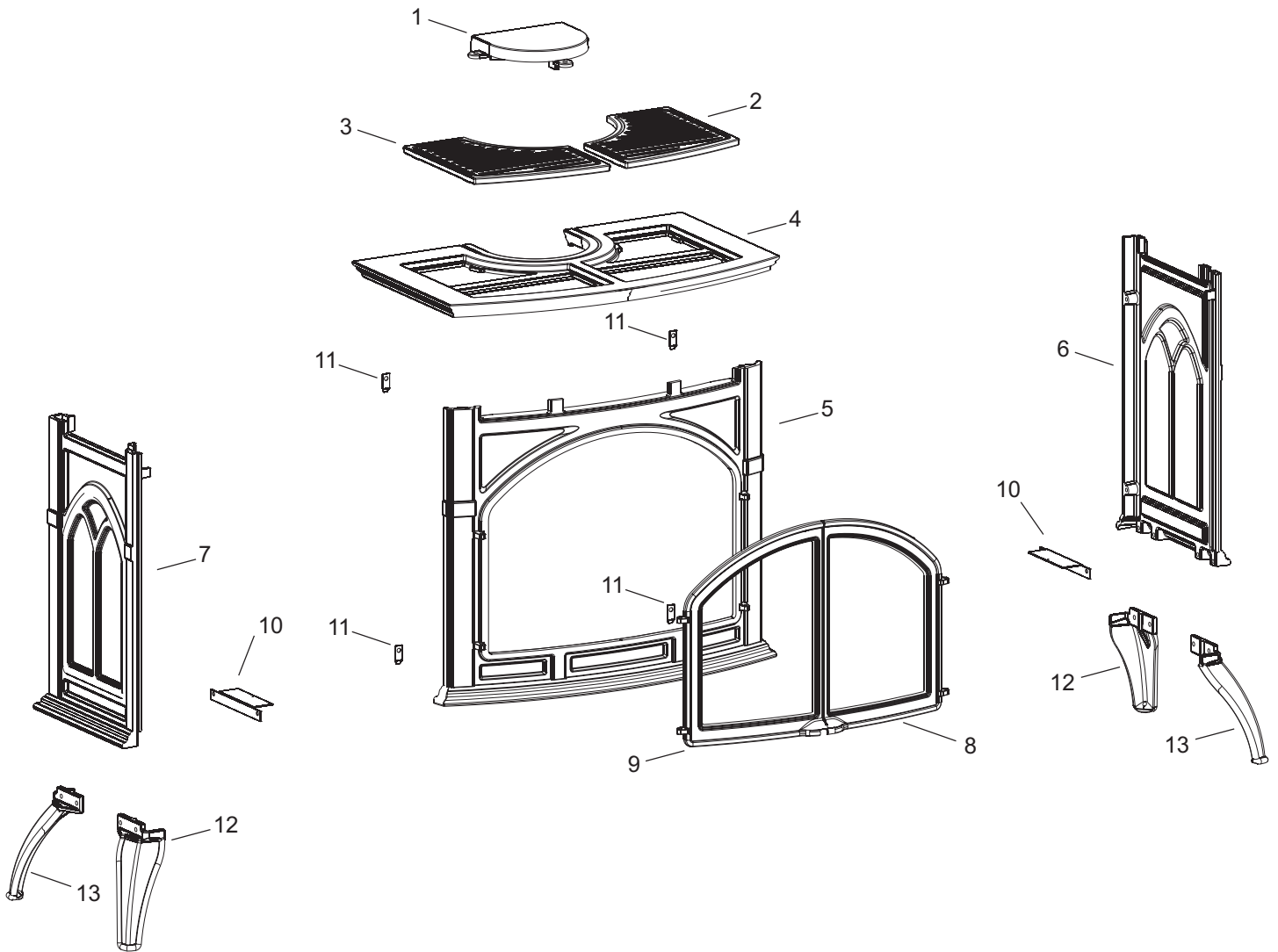

ACCESSORY SIDE SHELVES INSTALLATION INSTRUCTIONS

Installing Accessory Side Shelves:

1. Remove cast iron or stone inlay inserts from casting top and carefully set them aside.
2. Remove cast iron top from stove and place upside down on a flat, soft smooth surface to avoid damage.
3. Remove (4) 1/4-20 hex head bolts from the outer edges of cast iron top.
4. Place left and right side shelves in place shown in Figure 19.
5. Replace (4) 1/4-20 hex head bolts to attach side shelves to cast iron top, be sure shelf is tight to casting top before fully tightening bolts.
6. Remove (8) 1/4-20 hex head bolts from side shelves.
7. Replace cast iron top on unit.

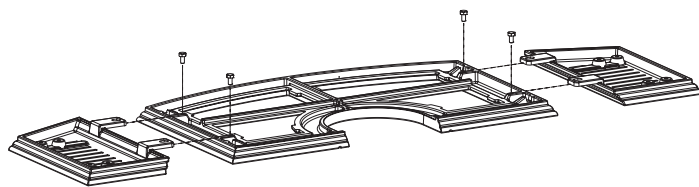

Figure 19

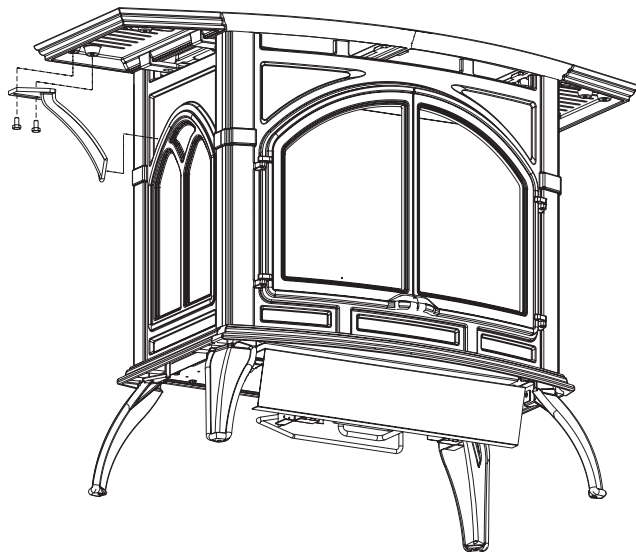
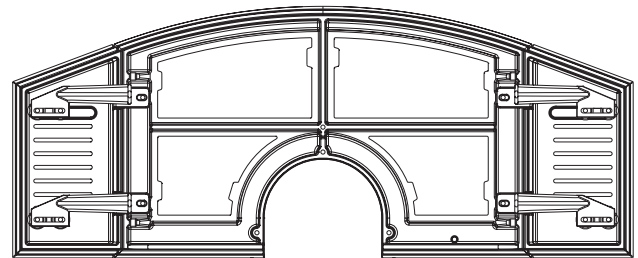

Figure 20

8. Attach side shelf supports one at a time, using (2) 1/4-20 hex head bolts per support, sliding support flush to casting before fully tightening bolts as shown in Figure 20.
9. Replace cast iron or stone inlay inserts into casting top.

Note: Be sure to remove side shelf supports prior to removing cast iron top to eliminate potential scratching or chipping to the cast iron sides.

Note: Due to inherent properties of the casting process, non-combustible shims may be required to level accessory side shelves to the casting top. These shims are provided in the form of washers to be used on either side of the bolts. See Figure 19. If accessory shelf angles downward, toward the floor, washer(s) will need to be added to the center side of the bolt. Conversely, if the accessory side shelf angles upward, toward the ceiling, washer(s) will need to be added to the outside of the top casting side of the bolt. See Figure 22.



BOTTOM VIEW
Figure 21

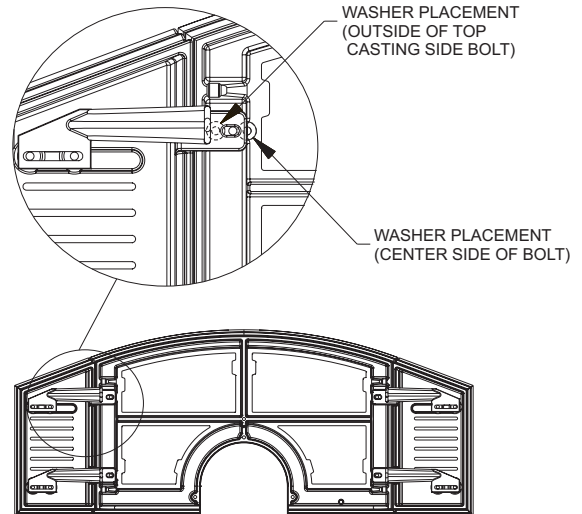

BOTTOM VIEW
Figure 22

OPTIONAL STONE INLAY INSTALLATION INSTRUCTIONS

Installation of Optional Stone Inlay

1. Remove left cast iron insert and right cast iron insert from casting top.

2. Insert left stone inlay and right stone inlay into casting top.
3. Installation of stone inlay is completed.

OPTIONAL BLOWER INSTALLATION INSTRUCTIONS

Installing Optional CIB3 Blower

1. Loosen, but do not remove, four (4) hex-head screws located on the exterior, bottom of the appliance.
2. Position the blower assembly at the rear of the appliance. The blower assembly has four (4) keyholes for attachment to the exterior, bottom of the appliance.
3. Place the large diameter holes in the keyholes over and behind the four (4) hex-head screws that were loosened in Step 1. Push inward on the blower assembly to lock the keyholes into position behind the screws. Tighten four (4) hex-head screws to secure blower assembly to exterior, bottom of the appliance.
4. Remove wire channel-left from appliance by removing (2) 10 x 1/2" screws on left side of the appliance. Note: Some units require a new wire channel. If Rheostat mounting holes are missing from part removed from unit, discard wire channel removed from unit and continue installation with appropriate wire channel shipped with blower. See Figure 23.
5. Route fan control wires through rectangular notch on wire channel - left.
6. Attach 1/4" push-on terminal from blue wire on the fan control to the AUTO (top) tab on the switch.
7. Attach 1/4" push-on terminal from black wire to the OFF (middle) tab on the switch.
8. Attach 1/4" push-on terminal from white wire on the fan control to the ON (bottom) tab on the switch.
9. Insert AUTO/OFF/ON switch into rectangular notch on wire channel - left.
10. Install rheostat through hole in wire channel and align small tab with small hole.
11. Use an 11/16" wrench to tighten rheostat nut on stationary portion of knob stem of the rheostat. Note: Nut is self-tapping and can be started at an angle.
12. Push rheostat knob onto knob stem until fully seated.
13. Bend the fan control tab, located on the left side of the back of the unit, inward toward the unit. See Figure 23. Be sure tab is bent at least 90 degrees to allow fan control bracket to slide into slot.
14. Attach fan control with bracket onto rear cover with two (2) 10 x 1/2" screws provided in hardware package.
15. Route wires from fan control and ON/OFF/REMOTE switch within wire channel.
16. Attach wire channel to channel divider with two (2) 10 x 1/2" screws from Step 4.
17. Installation of optional CIB3 blower is completed.

Fan Control

The fan control is a non-adjustable automatic type. The fan control will require between 5 and 10 minutes of main burner operation before the fan control "closes" and activates the blower. The blower will continue to run between 5 and 10 minutes after the main burner shuts off, before the fan control "opens" and deactivates the blower.

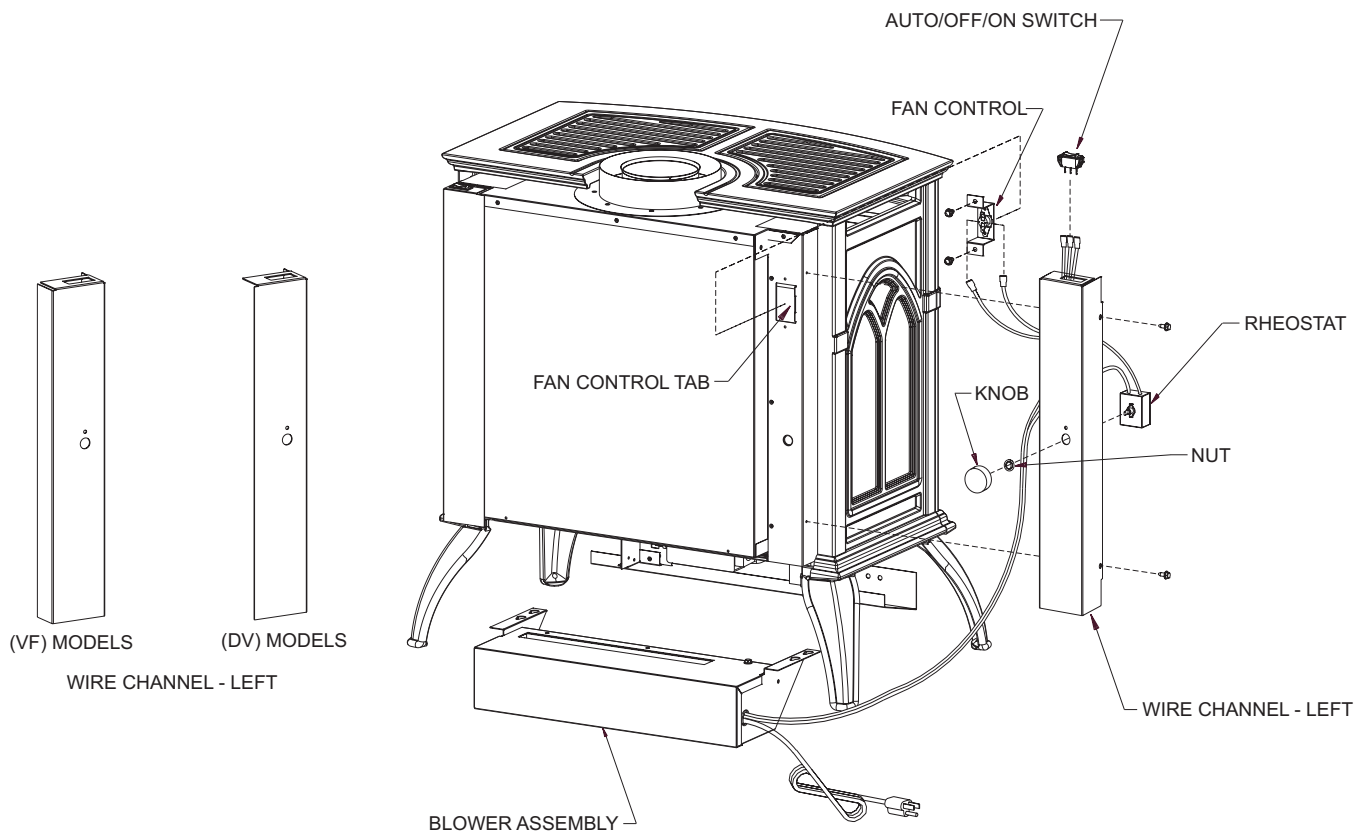

Figure 23

OPTIONAL BLOWER INSTALLATION INSTRUCTIONS

Cleaning

The blower wheel will collect lint and could require cleaning once a year. If the air output decreases or the noise level increases, it indicates a dirty wheel.

Blower Motor

The blower motor does not have oiling holes. Do not attempt to oil blower motor.

Wiring

The appliance, when installed, must be electrically grounded in accordance with local codes or, in the absence of local codes, with the *National Electrical Code, ANSI/NFPA 70* or *Canadian Electrical Code, CSA C22.1*, if an external electrical source is utilized. **This appliance is equipped with a three-prong [grounding] plug for your protection against shock hazard and should be plugged directly into a properly grounded three-prong receptacle. Do not cut or remove the grounding prong from this plug.** For an ungrounded receptacle, an adapter, which has two prongs and a wire for grounding, can be purchased, plugged into the ungrounded receptacle and its wire connected to the receptacle mounting screws. With this wire completing the ground, the appliance cord plug can be plugged into the adapter and be electrically grounded.

CAUTION: Label all wires prior to disconnection when servicing controls. Wiring errors can cause improper and dangerous operation. Verify proper operation after servicing.

WARNING:
Unplugging of blower accessory will not stop the heater from cycling. To shut heater off: Turn temperature dial or thermostat to lowest setting. Turn knob on gas control to "OFF," depressing slightly. Do not force.

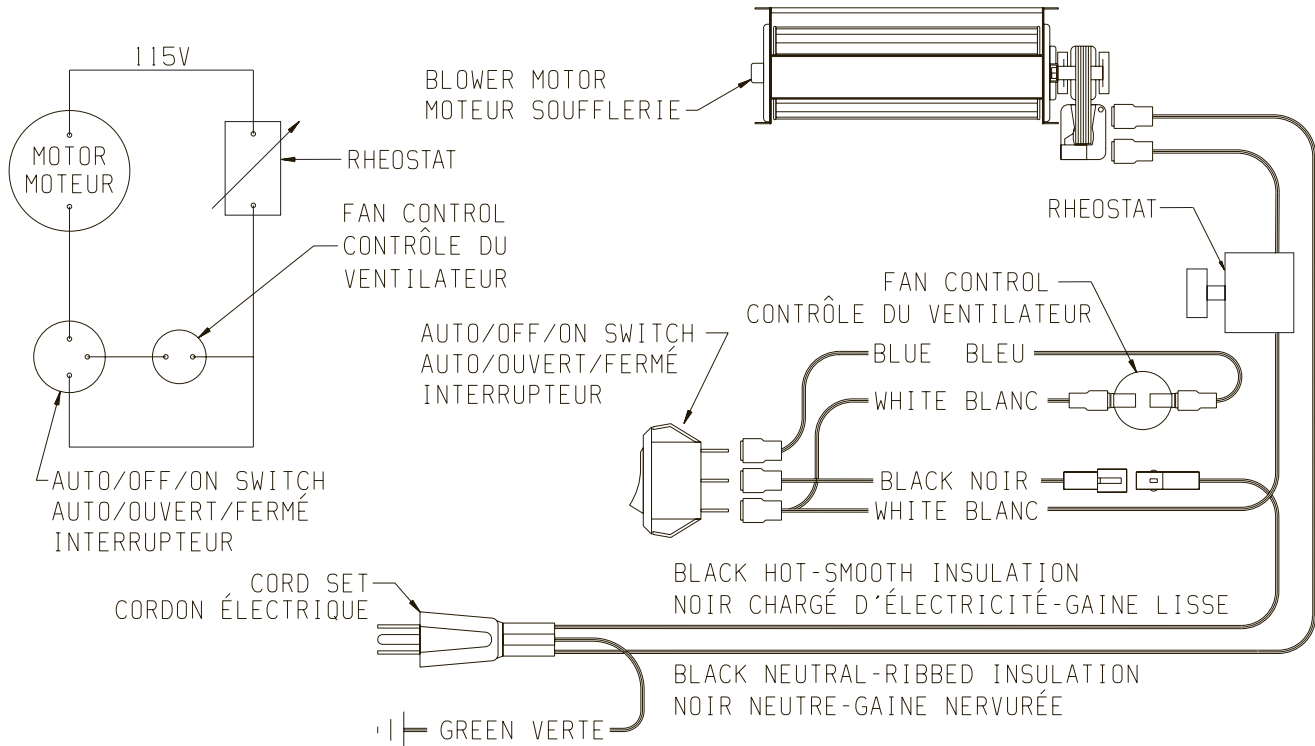

IF ANY OF THE ORIGINAL WIRE AS SUPPLIED WITH THIS UNIT MUST BE REPLACED, IT MUST BE REPLACED WITH NO. 18, 150°C WIRE OR ITS EQUIVALENT.
 SI UN DES FILS ÉLECTRIQUES ORIGINAUX, VENANT DU FABRICANT AVEC CETTE UNITÉ, DOIT ÊTRE REMPLACÉ, VOUS DEVEZ LE REMPLACER AVEC UN FIL ÉLECTRIQUE DE NUMÉRO 18, 150°C OU L'ÉQUIVALENT.

Figure 24

OPTIONAL BLOWER INSTALLATION INSTRUCTIONS

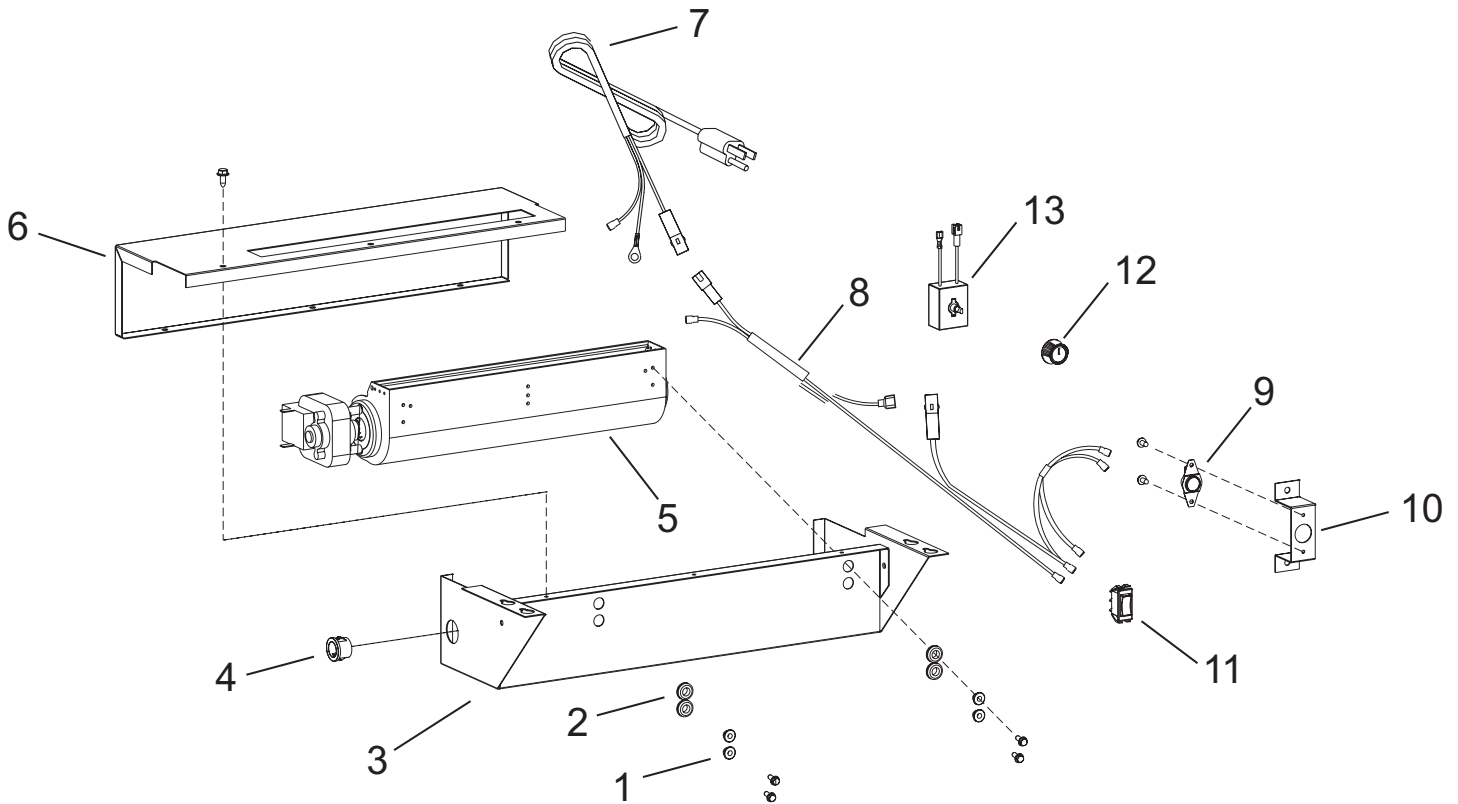

PARTS LIST		
INDEX NUMBER	PART NUMBER	DESCRIPTION
1	R-1454	BRASS BUSHING
2	R-1499	RUBBER GROMMET
3	24231	BLOWER HOUSING
4	R-1410	STRAIN RELIEF BUSHING
5	R-9927	BLOWER ASSEMBLY
6	24225	BLOWER COVER
7	R-6159	CORD SET
8	R-9699	WIRE HARNESS
9	R-2503	FAN CONTROL
10	24222	FAN CONTROL BRACKET
11	R-2805	AUTO OFF/ON SWITCH
12	R-4192	RHEOSTAT KNOB
13	18879	RHEOSTAT



Empire Comfort Systems
 918 Freeburg Avenue
 Belleville, Illinois 62220-2623

Web Site: www.empirecomfort.com

The Heritage Cast Iron Stoves

Models:

VFP30CA30B, VFP30CA30F, VFP30CA30M, VFP30CA30S,
 VFP30CA30W

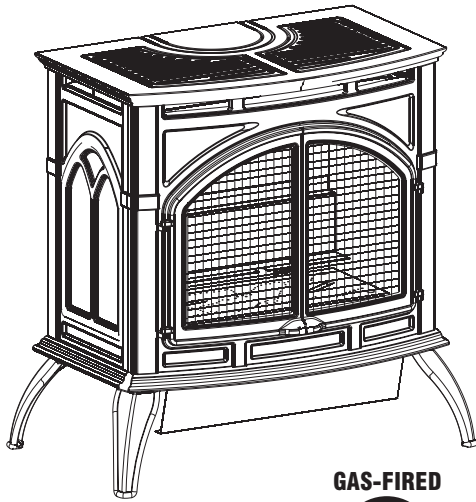

Specifications	
Model	VFP30CA30(B,F,M,S,W)
Input BTU/HR (KW/H) Maximum	32,000 (9.4)
BTU/HR (KW/H) Minimum	22,400 (6.6)
Height	27 3/4" (704.9 mm)
Width	28 1/16" (712.8 mm)
Depth	17 1/8" (435.0 mm)
Gas Inlet (Pipe)	3/8" (9.5 mm)

Clearances

In selecting a location for installation, it is necessary to provide adequate accessibility clearances for servicing and proper operation.

Locating the Vent Free Cast Iron Stove

When facing the front of the appliance the following minimum clearances to combustible construction must be maintained.

Top of appliance (ceiling)	36 inches	Heater Corners (45° angle) to Wall	4 inches
Rear Wall	2 inches	Floor	0 inches
Side Wall	6 inches		

Provide adequate clearances around air openings.

Adequate accessibility clearances for purposes of servicing and proper operation must be provided.

Installation on Rugs and Tile

This appliance must be installed on a flat, solid, continuous surface (e.g. wood, metal, concrete). This may be the floor, or it may be raised up on a platform to enhance its visual impact. The appliance may be installed on carpeting, vinyl, wood flooring or other combustible material.

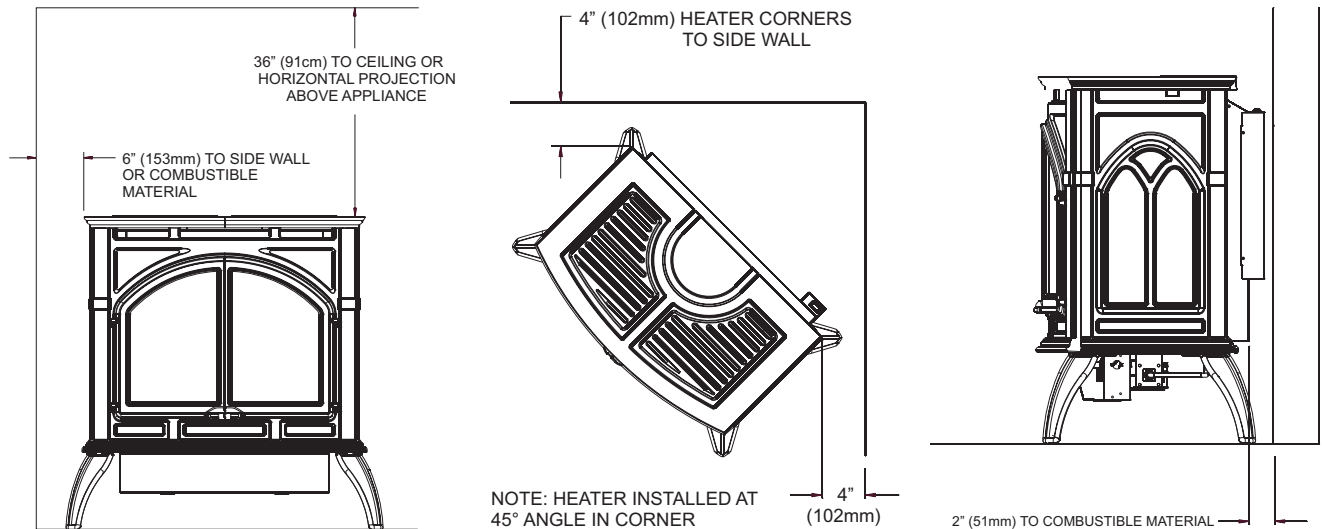



Empire Comfort Systems Inc.
918 Freeburg Ave. Belleville, IL 62220
PH: 618-233-7420 or 800-851-3153
FAX: 618-233-7097 or 800-443-8648
info@empirecomfort.com

www.empirecomfort.com