

This Owner's Manual is provided and hosted by [Appliance Factory Parts](#).

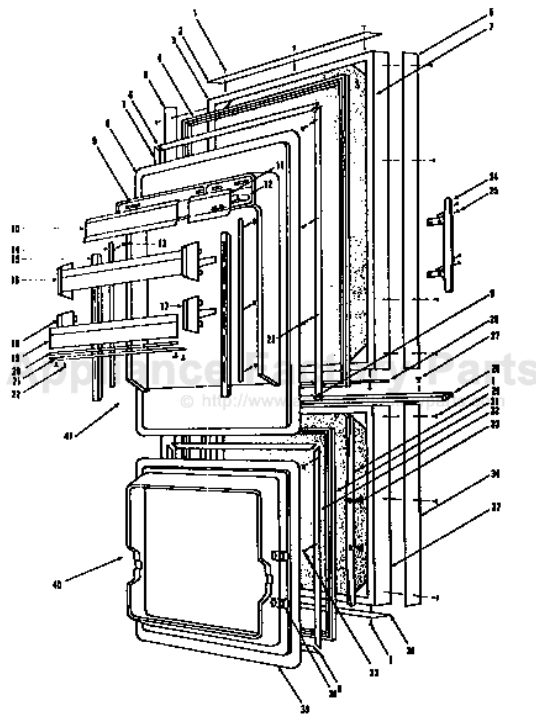

SUBZERO 2711 Owner's Manual

[Shop genuine replacement parts for SUBZERO 2711](#)



3/98

[Find Your SUBZERO Refrigerator Parts - Select From 117 Models](#)

----- Manual continues below -----

2711 DOORS

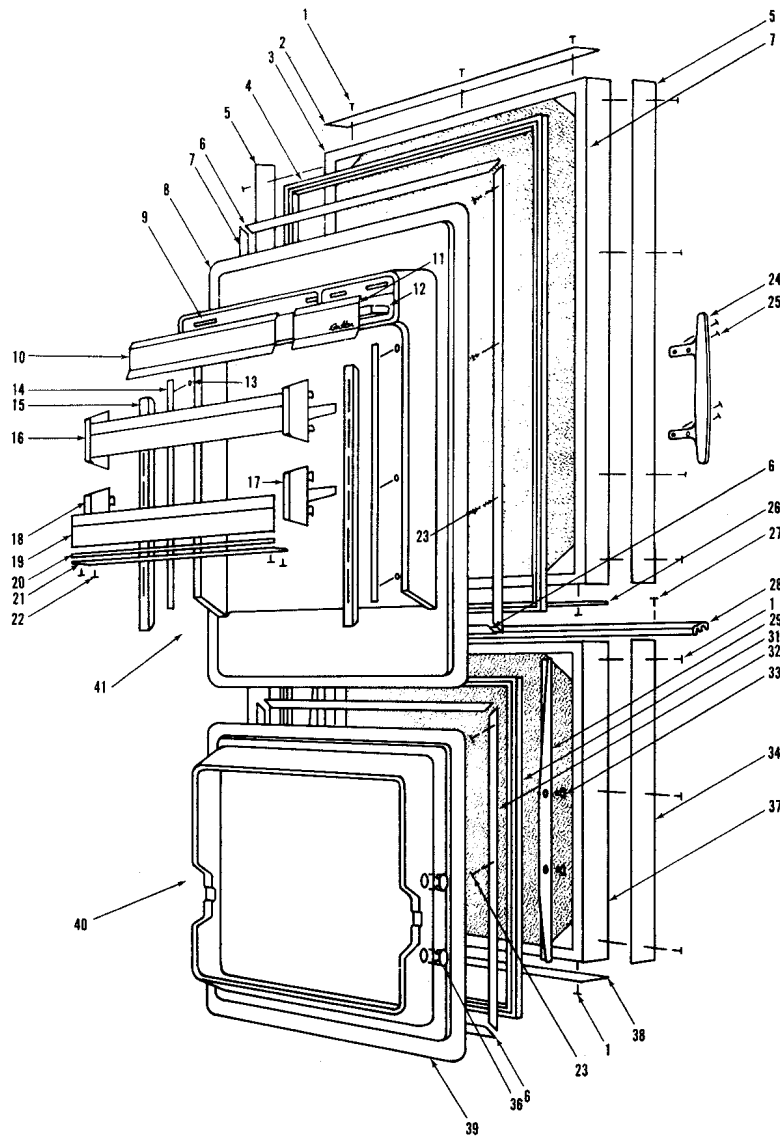

Item #	Part #	Description	Item #	Part #	Description
21	2-8061-01	Door Shelf Tray, 26-13/16	1	6-20-004-0	Screw, #4-24 x 1/2 Truss Head
22	6-20-039-0	Screw, #6 x 3/8 PH T25 Flat Head	2	2-2182-01	Top Right or Bottom Left Door Trim, 2 x 34-5/16
23	6-20-041-0	Screw, #8-18 x 1/2 Slot Head Hex	2	2-2182-02	Top Left or Bottom Right Door Trim, 2 x 34-5/16
24	3-51-001-0	Door Handle, 13-1/2	3	0-17062-0	Refrigerator Door Shell
25	6-11-001-0	Bolt, #10-24 x 1/2 Flat Head UC	4	3-21-008-0	Door Gasket, 33-13/16 x 41-1/8
26	2-2111-02	Top Left or Bottom Right Door Trim, 2 x 34-5/16	5	2-2182-18	Refrigerator Side Door Trim
	2-2111-01	Top Right or Bottom Left Door Trim, 2 x 34-5/16	6	3-42-022-0	Gasket Retainer, 33-5/16
27	6-11-001-0	Bolt, #10-24 x 1/2 Flat Head UC	7	3-42-023-0	Gasket Retainer, 40-7/16
28	3-51-552-0	Door Handle, 5/8 x 3 x 34-5/16	8	0-18246-0	Refrigerator Door Liner
29	0-18242-1	Door Support Rail, Right Hand	9	3-42-005-0	Butter Door Rod, 3/16 x 2
	0-18242-2	Door Support Rail, Left Hand	10	3-48-035-0	Dairy Door, 4.875 x .25
31	3-21-068-0	Door Gasket, 33-13/16 x 25-1/4	11	3-48-036-0	Butter Door, 4.875 x 6.88
32	3-42-019-0	Gasket Retainer, 24-9/16	12	3-44-001-0	Butter Dish, 3-1/3 x 6-1/3
33	6-11-045-0	Bolt, 1/4-20 x 1/2 Whiz Lock	13	5-15-032-0	Nut, #8-32 Pa1 (D0332075)
34	2-2182-16	Freezer Side Door Trim, Right Hand	14	4-15-018-0	Ladder Holder Assembly, 19-1/2
	2-2182-17	Freezer Side Door Trim, Left Hand	15	2-2145-16	Door Shelf Ladder
36	3-55-023-0	White Plastic Plug, 3/4	16	4-33-011-0	Door Shelf Assembly, 29-1/3
37	0-17061-0	Freezer Door Shell	17	3-60-022-1	Door Shelf End, Right Hand
38	2-2182-15	Freezer Bottom Door Trim	18	3-60-022-2	Door Shelf End, Left Hand
39	0-18241-0	Freezer Door Liner	19	3-51-011-0	Door Shelf Guard, 28-3/8
40	4-13-067-0	Freezer Drawer	20	1-2163-00	Door Shelf Support, 25-7/8
41	4-13-068-1	Refrigerator Door, Right Hand			
	4-13-068-2	Refrigerator Door, Left Hand			

2711 SYSTEM VIEW

Item #	Part #	Description	Item #	Part #	Description
1	3-11-078-0	Start Relay, Refrigerator	49	0-23227-0	Freezer Evaporator Cover
	3-11-081-0	Start Relay, Freezer	50	6-22-021-0	Stand-Off Heater Clip
2	3-11-079-0	Overload, Refrigerator	51	2-6041-01	Condensate Heater Loop
	3-11-082-0	Overload, Freezer	52	0-16494-0	Drain Pan, 1.3 x 13.5 x 19.5
3	3-09-001-0	Base Valve, 1/2 x 3/8	53	2-6004-11	Freezer Drain Tube
4	3-15-001-0	Rubber Mount, 5/8 x 1-1/4	54	3-42-076-0	Drain Pan Holder
5	6-15-022-0	Nut, 5/16-18 Hex Zinc	55	3-42-067-0	Screw Spacer
6	6-16-003-0	Spacer, 5/16 x 7/16 x 5/8	56	6-20-044-0	Screw, #10 x 11/16 Type B Flat Head
7	3-11-090-0	Terminal Cover	57	3-06-013-0	Fan Switch
8	3-11-091-0	Terminal Cover Strap	58	6-11-005-0	Bolt, #8-32 x 3/8 Truss Head
9	3-11-080-0	Freezer Compressor (FN66-F11R)	59	3-01-232-0	Control Knob
10	4-25-077-0	Freezer Heat Exchanger Assembly	61	6-20-006-0	Screw, #8-32 x 1/2 Pan Head
11	4-32-171-0	Cabinet Wiring Harness	62	3-09-002-0	Solenoid Valve
12	1-6008-00	Water Inlet Tube, 6"	63	3-52-005-0	Brass Insert, Solenoid
13	4-25-085-0	Refrigerator Heat Exchanger Assembly	64	3-21-003-0	Water Valve Gasket
14	3-11-077-0	Refrigerator Compressor (FN43-F67R)	65	3-52-021-0	Water Valve Fitting
16	4-28-041-0	Fan Shroud Assembly	66	3-52-022-0	Ball Sleeve
17	3-01-405-0	Drier, 1/4 x .095	67	3-52-023-0	Compression Nut
18	3-12-015-0	Dual Condenser	68	2-6006-03	Plastic Water Tube, 41"
19	4-32-182-0	Power Supply Cord Assembly	69	6-12-003-0	Tube Clamp; Plastic, 1/4
20	3-15-028-0	Condenser Fan Motor; 1.5 Watt, 4 Pole	70	4-20-031-0	Icemaker (8 Cavity)
21	3-21-034-0	Neoprene Silencer	71	3-01-245-0	Freezer Control
22	3-15-032-0	Fan Blade; 5 Prop, 7"	72	4-32-176-0	Defrost Heater Assembly
23	6-15-041-0	Nut, 1/4 x 20	73	3-01-101-0	Accumulator
24	6-20-049-0	Screw, #8-32 x 1/2 T25 Hex Slotted	74	4-32-093-0	Defrost Terminator Assembly
25	6-20-043-0	Screw, #8-18 x 1/2 PH Type B Pan Head	75	6-20-033-0	Screw, #8-18 x 3/8 Pan Head
26	3-22-016-0	Grommet, 3/16 x 7/16 x 9/32	76	6-12-012-0	Tube Clamp, 3/8 Steel w/Nut
27	1-8017-00	Fan Bracket, 3-1/2	77	0-23229-0	Freezer Evaporator Side
28	3-52-012-0	Brass Insert, 3/16 x 9/32	78	4-21-075-0	Refrigerator Evaporator Assembly
29	3-08-105-0	Defrost Timer	79	3-13-013-0	Refrigerator Evaporator, 1/5 x 10 x 29.6
30	6-20-001-0	Screw, #10-12 x 3/4 Pan Head	80	0-21137-0	Control Shim
31	3-06-014-0	Light Switch	81	3-01-246-0	Refrigerator Control
32	4-20-017-0	Refrigerator Fan Motor, 23 Watt	82	4-32-172-0	Unit Wiring Harness
33	6-12-016-0	Cord Clip; Plastic, 5/16 x 1/2	83	4-21-074-0	Freezer Evaporator Assembly
34	3-03-003-0	Light Bulb, 40 Watt	84	3-13-012-0	Freezer Evaporator, 3 x 7 x 21-1/2
35	3-05-003-0	Light Socket	85	3-49-007-0	Drain Cup
36	0-21099-0	Refrigerator Fan Shroud	86	6-20-008-0	Screw, #8-15 x 1/2 Truss Head
37	6-15-033-0	Wellnut, #10-32	87	4-20-016-0	Freezer Fan Motor, 23 Watt
38	0-21129-0	Refrigerator Fan Bracket	88	0-23228-0	Freezer Evaporator Fan Bracket
39	6-11-032-0	Bolt, #10-32 x 7/8 PH Truss Head	89	0-23226-0	Freezer Evaporator Fan Shroud
40	6-11-027-0	Bolt, #10-32 x 1/4 Round Head	90	3-22-025-0	Grommet, .203 x .312 x .234
41	3-15-021-0	Fan Blade, 4"	91	3-15-037-0	Fan Blade; Plastic, 5-9/16
44	4-19-005-0	Drain Trough Assembly, 1-3/4 x 30	92	0-23256-0	Freezer Air Duct
45	6-20-014-0	Screw, #8-15 x 3/8 Truss Head	93	6-20-012-0	Screw, #10-12 x 1/2 Truss Head
46	1-6014-00	Refrigerator Drain Tube, 1/2 x 72	94	3-52-003-0	Icemaker Nylon Nut, 1/4
47	6-20-023-0	Screw, #8-18 x 1/2 Hex Head		3-52-011-0	Water Inlet Fitting Assembly
48	6-12-005-0	Tube Clamp; Plastic, 5/8			

2711 SYSTEM VIEW

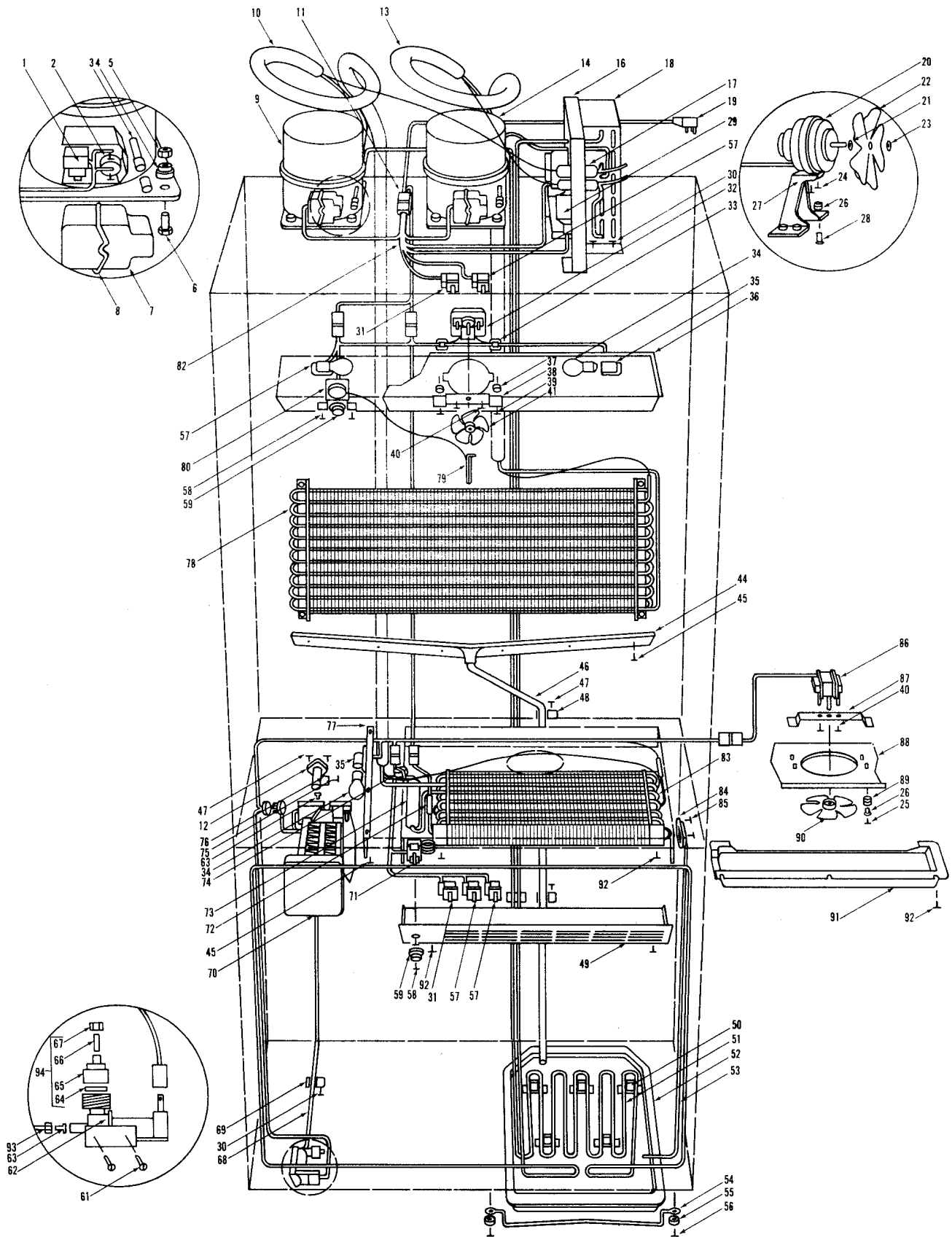

2711 COSMETIC VIEW

Item #	Part #	Description	Item #	Part #	Description
1	2-2107-01	Main Frame Angle	51	6-11-001-0	Bolt, #10-24 x 1/2 Flat Head UC
2	6-20-023-0	Screw, #8-18 x 1/2 Hex Head	52	6-20-039-0	Screw, #6 x 3/8 PH T25 Flat Head
3	2-2195-10	Left Main Frame Side; Right Hand, 69	53	3-42-007-0	Hinge Bearing, 1/4 x 5/8
	2-2195-28	Left Main Frame Side; Left Hand, 69	54	3-54-034-0	Door Hinge; Upper, Right Hand
4	6-20-021-0	Screw, #8-32 x 1/2 Flat Head		3-54-035-0	Door Hinge; Upper, Left Hand
5	0-16453-0	Back Cover & Shroud	55	4-24-003-0	Grille Assembly, 11 x 36
6	6-20-006-0	Screw, #8 x 32 x 1/2 Pan Head	56	3-58-010-0	Name Plate
7	4-28-041-0	Fan Shroud	57	6-15-014-0	Spring Grip Nut, 1/8"
8	4-28-029-0	Unit Shroud Assembly	58	4-15-031-0	Diffuser Assembly, 5-1/4 x 31-9/16
9	4-28-021-0	Compressor Shroud Assembly	59	3-45-016-0	U-Clip, .248 x .354 x .50
10	3-45-012-0	Grille Spring, 1/4 x 9-3/8	60	3-41-015-0	Plastic Egg Tray
11	6-20-005-0	Screw, #10-12 x 1/2 Pan Head	61	3-60-030-0	Wire Shelf, 14 x 14-3/4
12	2-2195-31	Main Frame Top; Right Hand, 36	62	4-15-082-1	Bottom Cabinet Hinge, Right Hand
	2-2195-32	Main Frame Top; Left Hand, 36		4-15-082-2	Bottom Cabinet Hinge, Left Hand
13	2-2195-27	Right Main Frame Side; Right Hand, 69	63	6-11-027-0	Bolt, #10-32 x 1/4 Round Head
	2-2195-04	Right Main Frame Side; Left Hand, 69	64	0-18238-1	Bottom Door Hinge, Right Hand
14	3-03-003-0	Light Bulb, 40 Watt		0-18238-2	Bottom Door Hinge, Left Hand
15	3-05-003-0	Light Socket	65	3-42-069-0	Bottom Door Hinge Cam, Right Hand or Left Hand
16	6-22-019-0	Support, .275 x .750	66	3-42-068-1	Bottom Cabinet Hinge Cam, Right Hand
17	6-22-007-0	Support, .44 x .63 x 1.53		3-42-068-2	Bottom Cabinet Hinge Cam, Left Hand
18	6-20-013-0	Screw, #8-15 x 3/4 PH Truss Head S/S	67	4-15-037-0	Crisper Trim Assembly, 31-5/8
19	2-2218-01	Right Refrigerator Shelf Ladder	68	3-21-025-0	Rear Crisper Seal, 5/8 x 3/8
20	2-2218-02	Left Refrigerator Shelf Ladder	69	4-15-049-0	Crisper Glass Assembly, 31.44 x 15.50
21	0-20062-0	Cold Plate Cover	70	3-21-022-0	Front Crisper Seal, 30-7/16
22	6-20-014-0	Screw, #8-15 x 3/8 Truss Head	71	3-48-073-0	Crisper Handle, .44 x 1.53 x 14.49
23	6-20-012-0	Screw, #10-12 x 1/2 Truss Head	72	3-48-068-0	Crisper Basket (Vegetable), 15.00 x 15.95
24	6-12-020-0	Cable Clip, .22 x .79 x .50		4-18-050-0	Crisper Front (Vegetable), 14.64
25	3-41-021-0	Crisper Slide, Center	73	6-20-029-0	Screw, #4-24 x 1/4 Truss Head
26	6-11-033-0	Screw, #10-32 x 1/2 Chrome Plated	74	3-41-028-0	Crisper Basket, 15.00 x 15.96 x 5.68
27	3-42-032-0	Roller, .250 x .75	75	3-42-030-0	Center Crisper Support
28	3-55-016-0	Hex Insert, #10-32	76	6-22-020-0	Support; Barrel Type, .225 x .406
29	6-20-045-0	Screw, #8-15 x 1 Type A Flat Head	77	3-48-067-0	Crisper Front (Meat), 14.64
30	3-41-020-1	Crisper Slide, Right Side		4-18-049-0	Crisper Basket (Meat), 15.00 x 15.95
	3-41-020-2	Crisper Slide, Left Side	78	3-51-554-0	Basket Handle, 1 x 1-11/16 x 28-3/4
31	6-20-044-0	Screw, #10 x 11/16 Type B Flat Head	79	3-41-058-1	Upper Freezer Basket, White
32	0-23236-1	Freezer Right Cabinet Slide		4-18-070-0	Upper Freezer Basket Assembly
	0-23236-2	Freezer Left Cabinet Slide	80	3-41-004-0	Ice Bucket Handle
	4-18-068-1	Freezer Cabinet Slide Assembly, Right Hand	81	0-23239-0	Ice Bucket
	4-18-068-2	Freezer Cabinet Slide Assembly, Left Hand	82	3-41-066-1	Upper Basket Divider, White
33	6-20-059-0	Screw, #12 x 1 PH Flat Head Steel	83	3-41-061-1	Lower Freezer Basket, White
34	6-20-015-1	Screw, #10 x 3/4 Type 23 PH Round Head	84	0-16500-0	Kickplate
35	3-42-098-1	Cabinet Support Insulator, Right Hand	85	6-20-005-0	Screw, #10-12 x 1/2 Pan Head Black
	3-42-098-2	Cabinet Support Insulator, Left Hand	86	3-57-003-0	Leveler Wrench, 26-3/4
36	3-42-090-0	Roller Bearing, 1.8 x .5	87	0-23230-0	Drawer Slide Front Shim
37	6-11-044-0	Bolt, 1/4-20 x 3/4 PH Flat Head	88	0-23231-0	Drawer Slide Rear Shim
38	3-43-004-0	Spacer, .75 x .26 x .22	89	0-16499-0	Kickplate Support
39	6-11-033-0	Screw, #10-32 x 1/2 Chrome Plated	90	2-8072-02	Mullion Breaker Strip, 32-7/8
40	6-11-026-0	Bolt, 1/4-20 x 1/2 Flat Head	91	2-8073-05	Refrigerator Right Side Breaker Strip, 39-13/16
41	6-20-034-0	Screw, #6-20 x 1/2 Pan Head	92	2-8073-06	Refrigerator Left Side Breaker Strip, 39-13/16
42	4-18-067-0	Freezer Drawer Slide Assembly	93	2-8073-15	Top & Bottom Breaker Strip, 32-7/8
43	3-42-095-0	Upper Basket Restraint	94	2-8073-23	Freezer Breaker Strip, Right Side
44	4-11-003-1	Right Base Assembly	95	2-8073-24	Freezer Breaker Strip, Left Side
45	3-57-004-0	Leveler Bolt, 3/8-18 x 1-1/2	96	2-8073-25	Freezer Bottom Breaker Strip, 32-11/16
46	6-20-001-0	Screw, #10-12 x 3/4 Pan Head	97	2-8085-02	Freezer Mullion Breaker Strip
47	3-57-002-0	Leveler Bolt, 3/8-18 x 4	98	3-55-030-0	Rear Drawer Glide, 1/2 x 1/4
48	4-11-003-2	Left Base Assembly	99	6-20-036-0	Screw, #6-32 x 7/8 Truss Head
49	6-11-007-0	Bolt, 1/4-20 x 5/8 Hex Head	100	6-16-009-0	Spacer, #10 x 3/8 x 1-7/16
50	0-18256-0	Top Cabinet Hinge	101	6-20-037-0	Screw, #8-18 x 2 Truss Head
			102	2-2203-01	Crisper Glass Front

2711 COSMETIC VIEW

