

2000 SERIES

USE & CARE GUIDE





2000  SERIES

SUB-ZERO 200 SERIES

Undercounter Refrigeration

Thank you for purchasing your new Sub-Zero 200 Series unit. With Sub-Zero, you can rely on a 50 year tradition of quality and reliability. The 200 Series brings together the latest and finest features in undercounter refrigeration.

Your Sub-Zero 200 Series unit is protected by a warranty that is one of the finest in the industry. Take a moment to read the warranty statement on page 14, and refer to it should service become necessary.

This Use and Care Guide will answer most of your questions about the features, operation and maintenance of your 200 Series unit. If you have questions that are not addressed here, call 800-222-7820.

Table of Contents

Features of the 200 Series

Models 245 and 249R 4

Models 249RP
and 249FF/FFI 5

Using Your Sub-Zero

Temperature
Controls 6

Door Closing 7

Operations 7

Sounds 7

Icemaker Operation 7

Caring For Your Sub-Zero

Ice Production 8

Maintenance and
Cleaning 8

Cleaning the
Condenser 8

Light Bulb
Replacement 9

Vacation Time 9

Troubleshooting

Guide 10-11

Keeping Food at its Best

Food Storage
Suggestions 12

Service For Your Sub-Zero

If You Need Service 13

Sub-Zero Warranty 14

200 SERIES MODELS

Model 245
Combination Unit

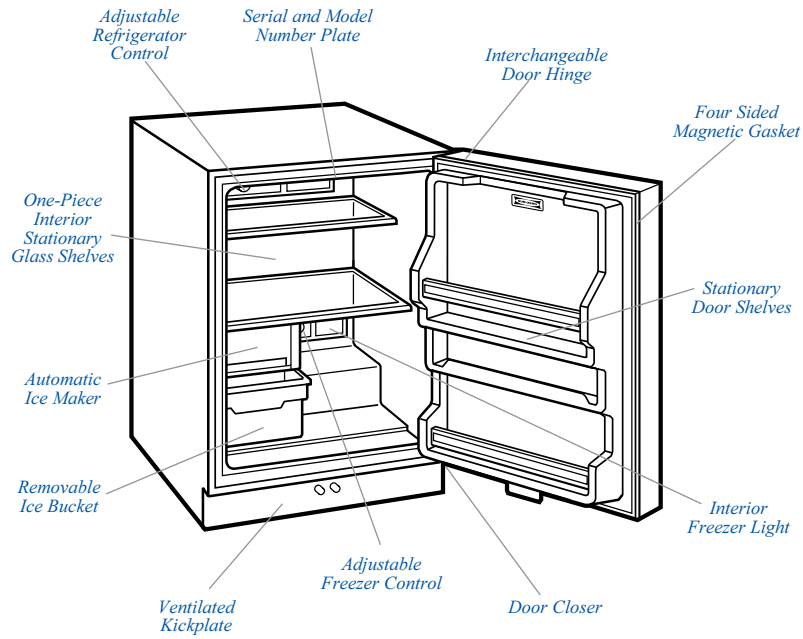

Model 249R
Combination Unit

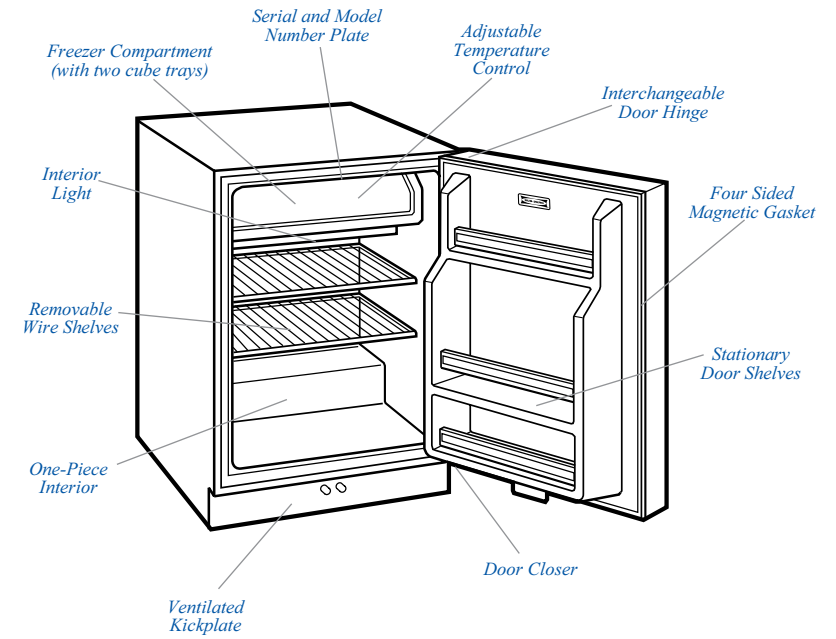

Model 249RP
All Refrigerator

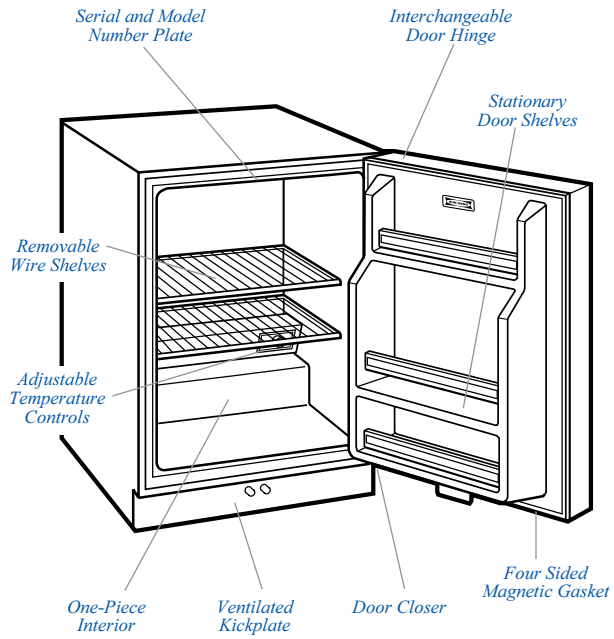

Model 249FF / FFI
All Freezer/
Freezer with Icemaker

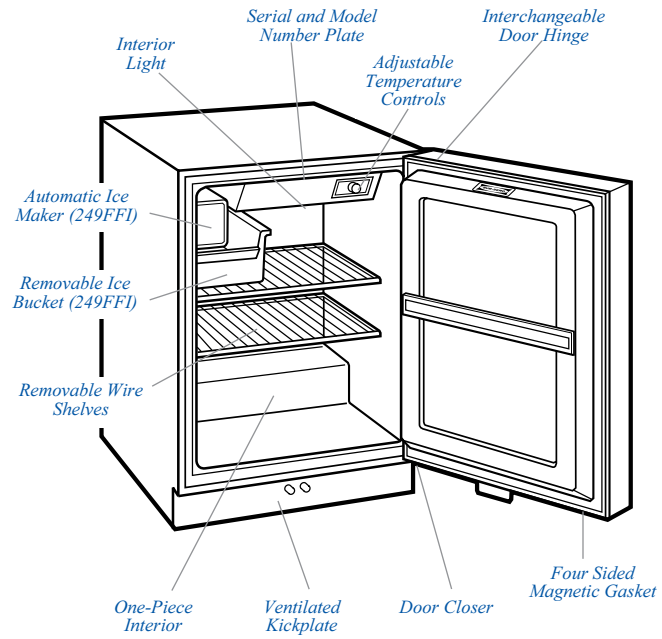

U SING YOUR SUB-ZERO

Temperature Controls

The importance of the installation of your Sub-Zero *cannot* be overemphasized. The proper installation of your unit is the responsibility of the selling dealer or installer. Any questions or problems pertaining to the installation should be directed to the selling dealer

Your new refrigerator and/or freezer was thoroughly inspected and tested before it was shipped from the Sub-Zero factory. During these procedures, the temperatures were preset to maintain approximately 38°F(3°C) in the refrigerator section and approximately 0°F (-18°C) in the freezer section (except 249R). If you wish to make temperature adjustments, simply turn the control knob so the indicator lines up with the desired number.

The higher the number the colder the temperature (#1 is the warmest and #7 is the coldest setting).

For the location of the control, refer to the model of your Sub-Zero on pages 4 and 5.

You should be aware it is normal for these temperatures to fluctuate slightly, depending on external influence such as: open door for extended periods, the degree of humidity present and room temperature.

Model 245

The freezer control is located on the back wall above and right of the icemaker assembly. The refrigerator control is situated left of center at the top of the refrigerator compartment (see Model 245 on page 4).

Model 249R (Manual Defrost)

The control is situated on the right hand side of the back wall in the upper freezer compartment (see Model 249R on page 4).

Model 249RP

The control is located on the right side of the back wall just below the lower shelf assembly (see Model 249RP on page 5).

Model 249FF

The control is found at the top of the freezer on the right side of the defrost blower assembly (see Model 249FF on page 5).

Door Closing

Model 245

The door on the Model 245 is equipped with a door closing cam system to assist in the closing of the door. As you close the door, the cam will take over at approximately the 15 degree position to assist in the closing of the door.

Models 249R, 249RP and 249FF

The refrigerator and freezer doors are both equipped with a spring-loaded door closure mechanism. As the doors are closed, the door closure engages at approximately the 15 degree position to assist the door in closing and sealing.

Operations

Condenser Fan

All undercounter units have one fan located behind the kickplate at the base of the unit. On all undercounter models the fan operates only when the compressor is running.

Evaporator Fan Models 245 and 249FF

A fan motor is located in the freezer section on the models listed above. These fans operate only when the compressor is running.

Automatic Defrost

For your convenience, Sub-Zero has equipped the following models with an automatic defrost system: 245, 249RP and 249FF.

NOTE: Model 249R is not equipped with automatic defrost. To manually defrost, turn the control knob to the off position.

Sounds

Certain noises may be evident with normal operation of the unit. Surrounding acoustics like walls, floors and cabinets may affect the sound level of your unit.

A gurgling sound or running water sound may be evident as the refrigerant circulates through the tubing.

During the icemaker cycle, you may hear the sound of ice dropping into the bucket or the solenoid valve while refilling the icemaker with water.

During the freezer defrost, you may hear crackling and/or sizzling as the heat from the defrost element clears the frost from the freezer coil and water runs into the defrost water pan.

While the compressor is in operation, a slight hum might be evident. During the startup and shutdown of the compressor, some vibration may occur lasting only a few seconds.

Icemaker Operation

Models 245 and 249FFI

The icemaker in Models 245 and 249FFI is fully automatic and has been factory pretested. To put into operation, it requires only a connection to the house water supply.

CARING FOR YOUR SUB-ZERO

Ice Production

Models 245 and 249FFI

The level of ice in the ice container is controlled by an ice level arm. When the containers are filled with ice, the ice level arm senses the level and shuts down the icemaker. As ice is used, the level drops and the level arm signals the icemaker to restore ice production.

The icemaker is designed to produce a more than adequate supply of ice for normal family consumption. The length of time between ice harvest cycles will vary depending on load conditions, door openings and ambient room temperatures. On the average, you can expect a harvest of ice every two hours.

If ice is not used regularly, it will tend to fuse together. To avoid this, empty the ice container periodically.

NOTE: To shut off icemaker, lift icemaker stop arm to the up or off position. See illustration.

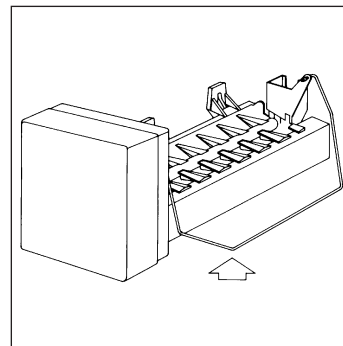

Automatic Icemaker

Maintenance and Cleaning

▲ CAUTION

For maintenance and cleaning, the circuit breaker to the refrigerator should be shut off and protective gloves worn.

For general cleaning of the refrigerator and freezer interior surfaces and removable parts, wash with a mild solution of soap and water to which a small amount of baking soda has been added. Rinse and dry thoroughly. Avoid getting water on lights and/or control dial.

To insure proper performance, the cleaning of your unit's condenser is required.

IMPORTANT NOTE: This should be performed every 3 to 6 months under normal use and living conditions.

Cleaning the Condenser

To expose the condenser, remove the kickplate at the base of the unit. To do this, remove the screws located at each corner of the kickplate.

Use a "soft" bristle brush and vacuum hose to remove the accumulation of dust and lint particles on the condenser.

IMPORTANT NOTE: Failure to properly clean this area could result in temperature lost and/or possible mechanical failure of the refrigerator and/or freezer.

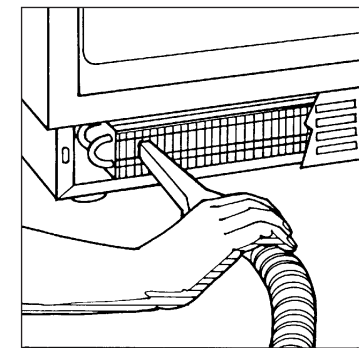

Cleaning the Condenser

Light Bulb Replacement

▲ CAUTION

Always shut off the circuit breaker to the unit and wear protective gloves when replacing light bulbs.

Model 245

To replace the refrigerator light bulb (25 watt), remove upper shelf and pull control knob off. Grip refrigerator control diffuser firmly on top and bottom and snap out of position. The light bulb is now accessible.

To replace the freezer light bulb (25 watt), pull control knob off. Grip freezer control diffuser firmly on top and bottom and snap out of position. The bulb is now accessible.

To reinstall, reverse procedure.

Model 249R

The light bulb (25 watt) is located beneath the freezer evaporator and is accessed by reaching up underneath behind the right hand side of the freezer section. Unscrew and replace.

Model 249RP

The light bulb (25 watt) is accessible by removing three screws which anchor the light bracket. Remove bracket and reach behind the light diffuser and unscrew bulb.

To reinstall, reverse procedure.

Model 249FF

The light bulb (25 watt) is mounted behind the left side of the blower fan assembly at the top of the back wall of the freezer. Unscrew and replace.

Vacation Time

For short vacations: Remove all perishable items. Shut off the icemaker. See *Icemaker Operation* on page 7. Do not change the settings of your controls.

For extended vacations: The control(s) to your refrigerator or freezer should be shut off. Empty all contents in the refrigerator/freezer and wash, rinse and dry interior of unit.

Vacant homes: If for any reason this unit is put into service on a temporary basis and later shut off, the control(s) to the refrigerator or freezer should be shut off.

For extended vacations or vacant homes, you should block door(s) open slightly. About one inch, so fresh air can circulate and keep interior dry. You should also turn off power to the unit or loosen light bulb(s).

▲ CAUTION

The moisture developed during even the shortest amount of running time could attack the metal parts if the doors are left closed after shutting down. Be sure the doors are blocked open after any operation.

TROUBLESHOOTING GUIDE

If you think that your refrigerator is not operating properly, check the following before calling your Sub-Zero Factory Authorized Service Center or dealer. This guide may save you time and the expense of a service call.

If refrigerator/freezer is not operating:

- Is there electrical power to equipment?
- Is home fuse blown or circuit breaker off?
- Is refrigerator/freezer control on?
- Is condenser clean?
- Has door been left open? Be sure no foods are obstructing proper door closing.
- If still not running, unit may be in defrost; wait 30 minutes to see if unit will restart.

If refrigerator/freezer is warmer than usual:

- Check control for proper setting.
- Has door been left open too long?
- Have you recently added a large quantity of food?
- Is condenser behind grille clean?

If refrigerator/freezer runs too much:

- Is condenser behind grille clean?
- On hot days and warm room ambients, the motor runs longer.
- Have doors been open for extended times or large amounts of food added?

If refrigerator/freezer is frosted up:

- Have the doors been left open?
- Are doors closing and sealing properly?

If you hear unusual noises:

- These may be normal operating sounds (see page 7).

If condensation forms inside the unit:

- This is normal during high humidity and frequent door openings.
- Are doors closing and sealing properly?

If condensation forms on the outside:

- It is possible during periods of high humidity that some condensation could appear. This condition will subside when humidity levels drop. If condensation is excessive, contact your Sub-Zero Factory Authorized Service Center.
- Be sure doors are closed and gaskets are sealing.

If it is too hot around freezer compartment:

- Clean condenser.

If there is odor in the unit and ice:

- Completely clean the unit.
- Cover foods tightly.

If light bulb needs replacing:

- Turn off circuit breaker to unit, wear gloves to protect against glass (see page 9).

If you hear occasional buzzing:

- Is water supply connected to icemaker and turned on?

If you need service:

- Please have model and serial number available.
- Call your nearest Sub-Zero Authorized Service Center. For the name of a local Sub-Zero Authorized Service Center, contact your dealer or Sub-Zero Freezer Company at 800-222-7820, write P.O. Box 44130, Madison, WI 53744, or e-mail us at customerservice@subzero.com.

K EEPING FOOD AT ITS BEST

Food Storage Suggestions

Shelf life of fresh foods varies depending on how fresh it is when you buy it. To keep your food fresher longer, follow the recommended storage tips.

- **Vegetables:** Wash vegetables in cool water and drain. Store in air-tight containers or plastic wrap. Vegetables do well in high-humidity storage.
- **Fruits:** Wash and dry fresh fruits. Store more aromatic fruits in plastic bags. Fruits do well stored in low humidity.
- **Prepackaged Meats:** Store in original packaging. After opening, rewrap tightly in plastic wrap or aluminum foil.

- **Fresh Meats, Fish and Poultry:** Remove store wrappings, then rewrap in plastic wrap, foil or waxed paper and refrigerate immediately.
- **Eggs:** Store eggs unwashed in their carton or a portable egg tray. Use within 2 weeks.
- **Milk, Cream, Cottage Cheese:** Keep carton closed. Store on refrigerator shelf and use within 5 days.
- **Cheese:** Store in original packaging until ready to use. After opening, rewrap tightly in plastic wrap or aluminum foil.
- **Leftovers:** Let cool and cover tightly with plastic wrap or foil. Airtight plastic containers work well to prevent drying out and odor transfer.

- **Freezer Storage:** Wrap foods in material designed for frozen food storage. The wrap must seal out air and moisture. *Do not refreeze thawed meats.*
- **Ice Cream:** The firmness of the ice cream will depend on its cream content. Higher quality ice creams usually have a higher cream content requiring colder freezer temperatures to maintain their firmness. Soft ice cream is not always an indication of a temperature problem.

Make sure your refrigerator and freezer doors close freely and completely. Overloading will affect temperatures inside the unit. Do not fill your freezer with large quantities of unfrozen foods expecting them to "fast freeze". Give the freezer ample time to circulate cold air around unfrozen items before adding additional items.

SERVICE FOR YOUR SUB-ZERO

If You Need Service ...

This Use and Care Guide gives you the tools necessary to preserve food at optimum quality in your Sub-Zero unit. Keep doors closed as much as possible whenever the unit is operating.

If you think that your refrigerator is not operating properly, refer to the *Troubleshooting Guide* on pages 10-11 before calling for service.

If you do need service, have the model and serial number when you call.

On undercounter models 245, 249R, 249RP and 249FF, the serial number is found on the inside cabinet liner at the top; open the door to read.

Call your nearest Sub-Zero Factory Authorized Service Center, your dealer or Sub-Zero Freezer Company at 800-222-7820, write P.O. Box 44130, Madison, WI 53744, or e-mail customerservice@subzero.com.

Sub-Zero Freezer Company Products Limited Warranty

RESIDENTIAL USE ONLY

Full 5 Year Sealed System Warranty and Limited 6th Through 12th Year Warranty on the Sealed System and Full 2 Year Warranty on Total Product

Full Five Year Sealed System Warranty

For five years from the date of original installation, your Sub-Zero warranty covers all parts and labor to repair or replace any components that prove to be defective in materials or workmanship in the sealed system. The sealed system consists of the compressor, condenser, evaporator, drier and all connecting tubing.

*Full Two Year Warranty**

For two years from the date of original installation, your Sub-Zero warranty covers all parts and labor to repair or replace any part of the product which proves to be defective in materials or workmanship.

Limited 6th Through 12th Year Warranty

From the 6th through the 12th year from the date of original installation, your Sub-Zero warranty covers all parts that prove to be defective in materials or workmanship in the sealed system (parts only). The sealed system consists of the compressor, condenser, evaporator, drier and all connecting tubing.

Terms Applicable To Each Warranty

All service provided by Sub-Zero under the above warranty must be performed by Sub-Zero factory authorized service centers, unless otherwise specified by Sub-Zero. Service will be provided in the home during the normal business hours. This warranty applies only to products installed for normal residential use. Details regarding a non-residential warranty are available upon request.

The warranty applies only to products installed in any one of the fifty states of the United States, the District of Columbia or the ten provinces of Canada. This warranty does not cover any parts or labor to correct any defect caused by negligence, accident or improper use, maintenance, installation, service or repair, including but not limited to improper removal and reinstallation (whether in the unit or at a remote location) of the condensing unit.

The remedies described above for each warranty are the only ones which Sub-Zero will provide, either under these warranties or under any warranty arising by operation of law. Sub-Zero will not be responsible for any consequential or incidental damages arising from the breach of these warranties or any other warranties, whether express, implied or statutory.

Some states do not allow the exclusion or limitation of incidental or consequential damages, so the above limitation or exclusion may not apply to you. This warranty gives you specific legal rights and you may also have other legal rights which vary from state to state.

To receive parts and/or service and the name of the Sub-Zero factory authorized service centers nearest you, contact your Sub-Zero dealer, distributor or Sub-Zero Freezer Company, Customer Service Department, P.O. Box 44130, Madison, Wisconsin, 53744-4130, call (800) 222-7820 or e-mail us at customerservice@subzero.com.

* Stainless Steel (Classic, Platinum & Carbon) doors, panels and product frames are covered by a limited 60 day parts and labor warranty for cosmetic defects.







Sub-Zero Freezer Company, Inc. 4717 Hammersley Road Madison, Wisconsin 53711 (800) 222-7820 or (608) 271-2233