

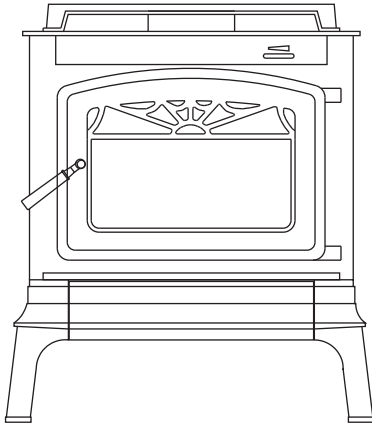

Windsor EPA Certified High Efficiency Wood Stove

Owner's Manual For Residential Installation



Models:
WR1000L02
WR1500L02
WR2000L02

This manual describes the installation and operation of the WR1000L02, WR1500L02 and WR2000L02 non-catalytic, wood heaters. This heater meets US Environmental Protection Agency emission limits for wood heaters.

SAFETY NOTICE

Read this entire manual before you install and use your appliance.
If not properly installed, a house fire may result. To reduce the risk of fire, follow the installation instructions.
Failure to follow instructions may result in property damage, bodily injury or even death.
Contact local building, fire officials or authorities having jurisdiction about permits, restrictions and installation inspection requirements in your area.

This stove is listed by OMNI-Test Laboratories of Portland, Oregon to meet UL1482 for the US and ULC-627 for Canada

NATIONAL
FIREPLACE
INSTITUTE



CERTIFIED
www.nficertified.org

We recommend that our woodburning hearth products be installed and serviced by professionals who are certified in the U.S. by the National Fireplace Institute® (NFI) as NFI Woodburning Specialists or who are certified in Canada by Wood Energy Technical Training (WETT).



6" Flue required

Do Not Discard This Manual: Retain for Future Use

CAUTION

After reading these instructions, if you have any doubt about your ability to complete your installation in a professional like manner you should obtain the services of an installer versed in all aspects as to the correct and safe installation. Do not use temporary makeshift compromises during installation.

Before Installation of Your Appliance

1. Check with the building inspector's office for compliance with local codes; a permit may be required.
2. This appliance requires a masonry or prefabricated chimney listed to ULC S629 (Canada) and UL103HT (U.S.). Sized correctly.
3. A 6" (152 mm) diameter flue is required for proper performance.
4. Always connect this unit to a chimney and **NEVER** vent to another room or inside a building.
5. **DO NOT** connect this unit to any duct work to which another appliance is connected such as a furnace.
6. **DO NOT** connect this unit to a chimney flue serving another appliance.
7. The connector pipe and chimney should be inspected periodically and cleaned if necessary.
8. Remember the clearance distances when you place furniture or other objects within the area. **DO NOT** store wood, flammable liquids or other combustible materials too close to the unit.

Refer to certification label on back of your unit for required clearances.

9. Contact your local municipal or provincial fire authority for information on how to handle a chimney fire. Have a clearly understood plan to handle a chimney fire. In the event of a chimney fire, turn air control to closed position and **CALL THE FIRE DEPARTMENT.**
10. **DO NOT** tamper with combustion air control beyond normal adjustment.
11. **DO NOT** install these units in a mobile home or trailer. These units are **NOT** mobile home approved.

Operation Precautions

Why the correct flue size is important - 6"

Draft is the force which moves air from the appliance up through the chimney. The amount of draft in your chimney depends on the length of the chimney, local geography. Nearby obstructions, and other factors. Too much draft may cause excessive temperatures in the appliance. An uncontrolled burn or a glowing red part or chimney connector indicates excessive draft. Inadequate draft may cause back puffing into the room and "plugging" of the chimney and/or cause the appliance to leak smoke into the room through appliance and chimney connector joints.

Today's solid fuel appliances are much more efficient than in the past. The units are designed to give you controlled combustion, as well as maximum heat transfer, using less fuel to do so.

The design of your new appliance is such that the exhaust "smoke" is now at lower temperatures than in the past, therefore requiring proper chimney size to give adequate draft. If your chimney is too large, the heating appliance will have a difficult time to raise the "chimney flue" temperature to give adequate draft, therefore causing a smoke back up, poor burn or both.

Should you experience such a problem call in a local chimney expert.

With the door closed, the rate of burning is regulated by the amount of air allowed to enter the unit through the air control. With experience you will be able to set the control for heat and burning time desired.

Once the required chimney draft is obtained, operate only with doors closed and open doors slowly when re-fueling. (This will reduce or eliminate smoke from entering the room).

Attempts to achieve higher output rates that exceed heater design specifications can result in permanent damage to the heater. The recommended wood load is level with the top of the firebricks.

Overloading may prevent sufficient air entering the heater to properly fuel the fire.

Operate this heater only with the door closed.

DO NOT BURN GARBAGE OR FLAMMABLE FLUIDS.

DO NOT USE CHEMICALS OR FLUIDS TO START THE FIRE.

ALWAYS PROVIDE A SOURCE OF FRESH AIR INTO THE ROOM WHERE THE UNIT IS INSTALLED. FAILURE TO DO SO MAY RESULT IN AIR STARVATION OF OTHER FUEL BURNING APPLIANCES AND THE POSSIBLE DEVELOPMENT OF HAZARDOUS CONDITIONS.

THIS HEATER IS EXTREMELY HOT WHILE IN OPERATION. SERIOUS BURNS CAN RESULT FROM CONTACT. KEEP CHILDREN, CLOTHING AND FURNITURE AWAY.

Optional Blower: Model S31105
120 V, 60 Hz, 0.75 Amps, 2900 rpm
DANGER: Risk of Electric Shock.
Disconnect power before servicing unit.
IMPORTANT: For optimum heater performance at "low" burn rate, operate the fan at low speed.

Figure 1
Stove Dimensions

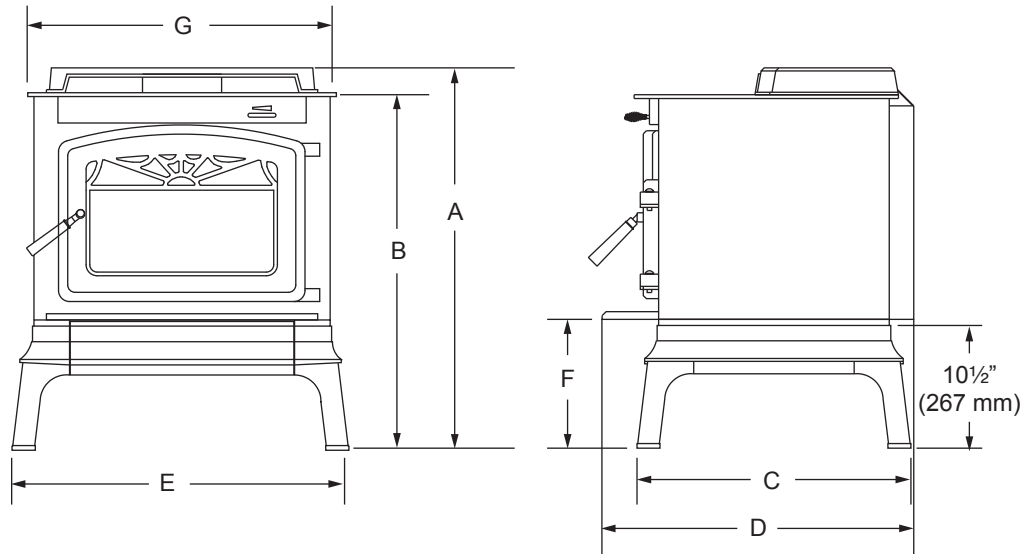

Model	A	B	C	D	E	F	G
WR1000L02	29" 737 mm	26 ³ / ₄ " 679 mm	17 ¹ / ₂ " 445 mm	20 ¹ / ₂ " 521 mm	24 ³ / ₈ " 619 mm	10 ³ / ₄ " 273 mm	23 ³ / ₄ " 603 mm
WR1500L02	30" 762 mm	27 ³ / ₄ " 705 mm	17 ³ / ₄ " 450 mm	22 ¹ / ₄ " 565 mm	28 ³ / ₄ " 730 mm	10 ³ / ₄ " 273 mm	28 ¹ / ₄ " 718 mm
WR2000L02	31" 787 mm	28 ³ / ₄ " 730 mm	21 ⁷ / ₈ " 556 mm	27" 686 mm	26 ¹ / ₂ " 673 mm	10 ³ / ₄ " 273 mm	26 ¹ / ₂ " 667 mm

Proposition 65 Warning: Fuels used in gas, wood-burning or oil fired appliances, and the products of combustion of such fuels, contain chemicals known to the State of California to cause cancer, birth defects and other reproductive harm.
California Health & Safety Code Sec. 25249.6

Installation

Contact your local building inspector prior to installation. A permit may be required in your area.

This Homeowner's Manual describes the installation and operation of the models: WR1000L02, WR1500L02, WR2000L02 non-catalytic wood heater. This heater meets US Environmental Protection Agency's emission limits for wood heaters. Under specific conditions this heater has been shown to deliver heat at the rates shown in Chart

Heat Output Ranges	
Model	Output Range BTU/hr
WR1000L02	10,600 to 26,100
WR1500L02	10,370 to 29,301
WR2000L02	11,800 to 32,300

1. Remove all parts from inside the stove body.
2. Select the proper location for the stove. These appliances must not be installed any closer than the minimum clearance to combustible materials. (Fig. 2) The stove must be installed on a noncombustible surface as shown on Page 7, Figure 4.
3. If noncombustible materials have been installed on the walls, obtain the minimum clearances from either the manufacturer of these materials or the local building inspector's office.
4. Install the refractory bricks. (Fig. 3) Be sure all bricks are in place.
5. Install the stovepipe INSIDE the flue collar on the top of the stove between the stove and chimney.
6. **DO NOT** use a grate to elevate the fire.

Failure to follow the minimum clearance requirements and noncombustible surface requirements may result in an unsafe installation.

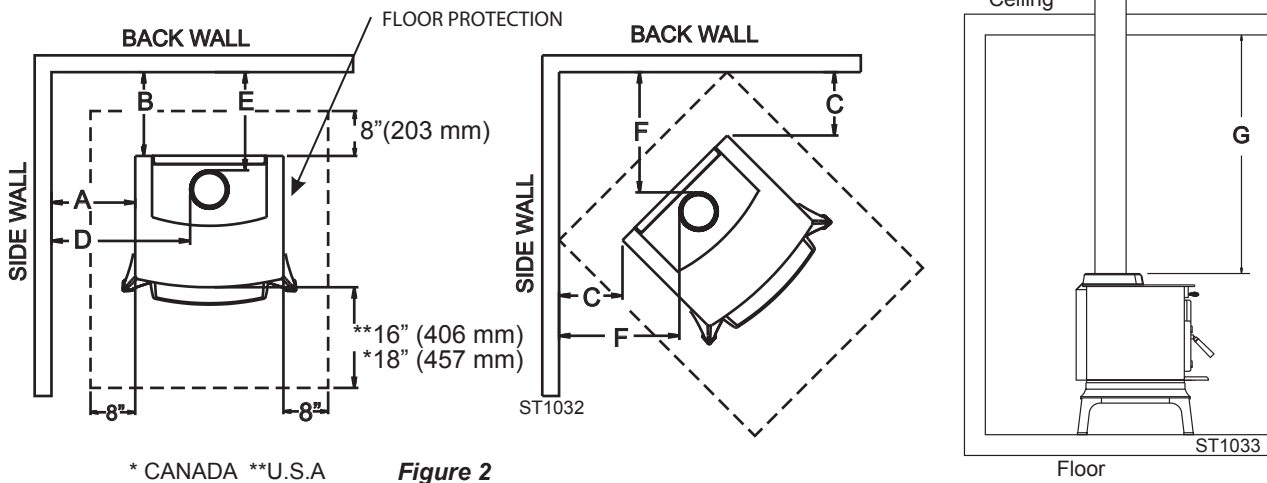

* CANADA **U.S.A

Figure 2
Clearance to Combustible Materials

WR1000 Series Clearances to Combustibles							
	A	B	C	D	E	F	G
Single wall	12"	12½"	7"	19½"	15"	15"	56"
Connector	(305)	(318)	(178)	(405)	(381)	(381)	(1422)
Double wall	8½"	8"	5½"	15½"	10"	13"	56"
Connector	(216)	(203)	(140)	(394)	(254)	(330)	(1422)

WR1500 Series Clearances to Combustibles							
	A	B	C	D	E	F	G
Single wall	11½"	9"	7"	21"	11½"	18"	54½"
Connector	(292)	(229)	(178)	(533)	(292)	(457)	(1384)
Double wall	6"	6"	4"	15"	8"	14"	54½"
Connector	(152)	(152)	(102)	(381)	(203)	(356)	(1384)

WR2000 Series Clearances to Combustibles							
	A	B	C	D	E	F	G
Single wall	15"	10"	9"	24½"	13"	19½"	54"
Connector	(381)	(254)	(229)	(822)	(325)	(495)	(1372)
Double wall	14"	10"	8"	23"	13"	18"	54"
Connector	(356)	(254)	(203)	(584)	(325)	(457)	(1372)

Unit must be placed on a noncombustible floor protection equivalent to 3/8" millboard. Floor protector must have min. R value of .893. Consult your local building authorities for further information.

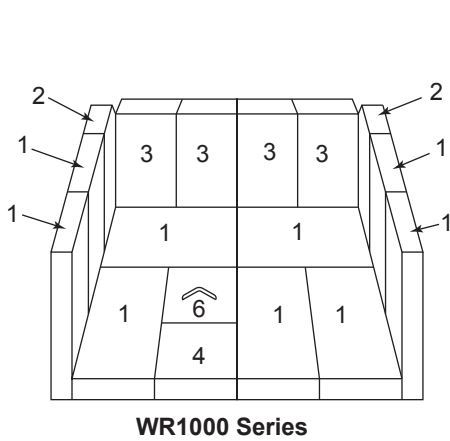

WR1000 Series

Figure 3
Fire Brick Installation

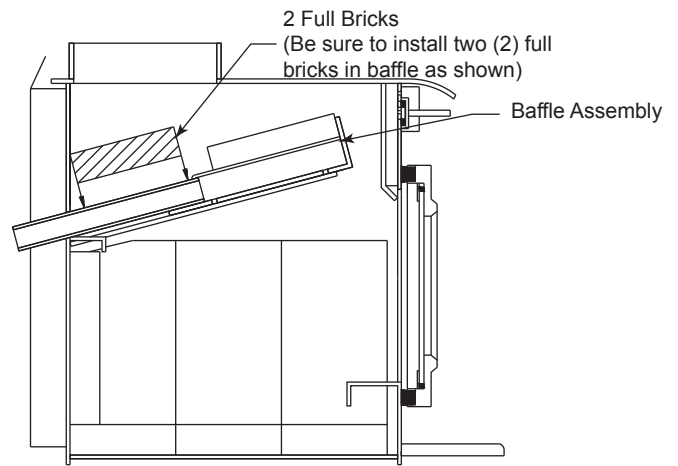

WR1000 and WR1500 Series

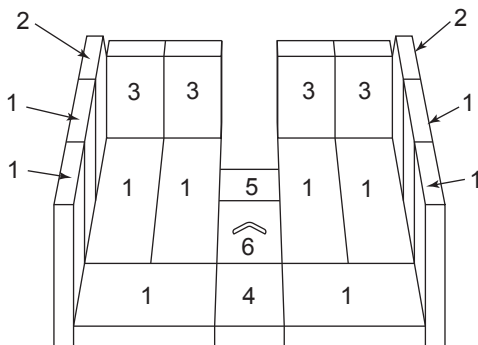

WR1500 Series

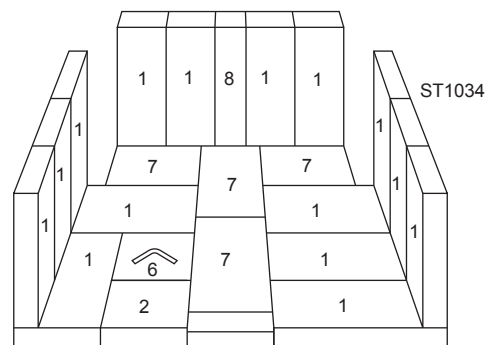

WR2000 Series

Item	Description	Part #	WR1000	WR1500	WR2000
1.	Firebrick Lt 9" x 4 ⁷ / ₁₆ " x 1 ¹ / ₄ " (229 x 113 x 32 mm)	S16040	11	12	15
2.	Firebrick Angle Cut	S16042	2	2	--
3.	Firebrick Lt 7 ¹ / ₄ " x 4 ⁷ / ₁₆ " x 1 ¹ / ₄ " (184 x 113 x 32 mm)	S16043	4	4	--
4.	Firebrick Lt 4 ¹ / ₂ " x 4 ⁷ / ₁₆ " x 1 ¹ / ₄ " (114 x 113 x 32 mm)	S16046	1	1	1
5.	Firebrick Lt 2 ³ / ₄ " x 4 ⁷ / ₁₆ " x 1 ¹ / ₄ " (70 x 113 x 32 mm)	S16224	--	1	--
6.	Brick for Ash Drawer	S16214	1	1	1
7.	Firebrick Lt 7 ³ / ₄ " x 4 ⁷ / ₁₆ " x 1 ¹ / ₄ " (197 x 113 x 32 mm)	S16222	--	--	4
8.	Firebrick Lt 9" x 2 ¹ / ₂ " x 1 ¹ / ₄ " (229 x 64 x 32 mm)	S16216	--	--	1

Floor Protection

Installation on a Concrete Floor

An appliance mounted on a concrete floor does not require floor protection.

Carpeting and any other combustible material shall not cover Floor Protector.

If a combustible surface is applied to the concrete floor, a clearance must be maintained equivalent to the area reserved for the floor protector. (Fig. 4)

Installation on a Combustible Floor

If the appliance is to be installed on a combustible floor or a combustible floor covering, it must be installed on a 3/8" (10 mm) thick noncombustible millboard floor protector or durable equivalent. The pad must be installed beneath the appliance extending 18" (457 mm) in Canada, 16" (406 mm) in the U.S. On any side equipped with a door, and 8" (203 mm) on all other sides. In the US, the pad must cover any horizontal chimney connector runs and extend 2" (51 mm) beyond each side.

A grouted ceramic floor-tile surface installed per local building code considered equivalent.

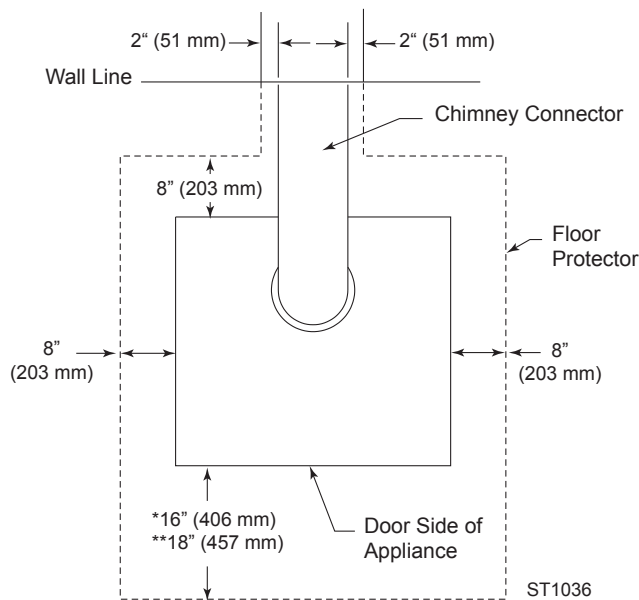
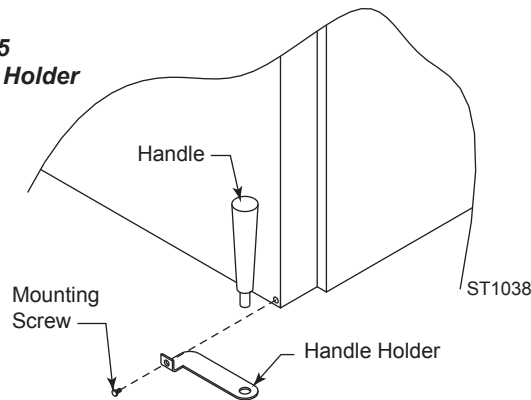

Figure 4
Floor Protector

Attach Handle Holder

Insert screw through handle holder and into lower left side of stove (when facing the front). (Fig.)

Figure 5
Handle Holder



Stove Pipe

1. A clearance of 18" (457 mm) between the stovepipe and combustible materials may be required. Check with authorities having jurisdiction in your area.
2. All pipe sections must be connected with the male end (crimped end) toward the stove.
3. Fasten the stove pipe to the flue collar by the use of three (3) sheet metal screws. Do the same at each additional joint to make the entire installation rigid.
4. Maintain the required diameter flue for the entire installation.
5. If you are connecting the stove to an old masonry flue, be sure to have it inspected for cracks and general condition.
6. It is recommended that no more than two (2) 90° bends be used in the stove pipe installation. More than two (2) 90° bends may decrease the amount of draw and possibly cause smoke spillage.
7. A damper is not required in this installation. Remove damper plate in the chimney or secure in the OPEN position.
8. Single wall flue pipe assemblies must not exceed 10 feet (3 m) in horizontal run.

Chimney

CONTACT YOUR LOCAL BUILDING AUTHORITY FOR APPROVED METHODS OF INSTALLATION.

1. This appliance requires a masonry or pre-manufactured chimney listed to ULC S629 (Canada) and UL 103HT (US) sized correctly.
2. If a masonry chimney is used, it is advisable to have your chimney inspected for cracks and check the general condition before you install your unit. Relining may be required to reduce the flue diameter to the appropriate functional size.
3. To help ensure a good draft, the top of the chimney should be at least 3 feet (914 mm) above the point of penetration through the roof, and be at least 2 feet (610 mm) higher than any point of the roof within 10 feet (3 m).
4. The chimney connector shall not pass through an attic, roof space, closet, concealed space, floor, ceiling, wall or any partition of combustible construction.
5. The minimum overall height of your chimney should be 15 feet (5 m) from the floor. (Fig. 6)
6. Do not use make shift compromises during installation.

Refer to chimney manufacturer's instructions.

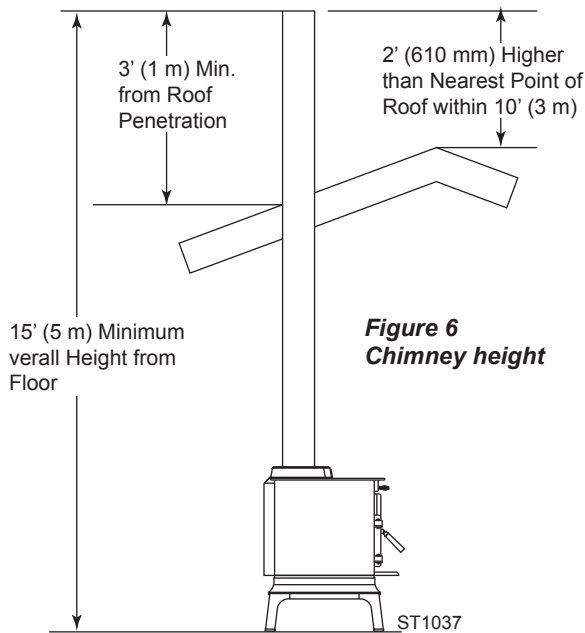

Figure 6
Chimney height

CAUTION: DO NOT open fire-door to a point where it would be in contact with the combustible sidewall.

Optional Fan - An optional heat exchange blower is available for this wood burning appliance. To order please see the local dealer where you purchased your appliance.

Operation

Do not use a grate or elevate fire. Build wood fire directly on hearth. When the stove is used for the first time the solvents in the paint will smoke off.

Wood

This heater is designed to burn natural wood only. Higher efficiency and lower emissions generally result when burning air dried seasoned hardwood, as compared to softwood or to green or freshly cut hardwood.

Only use dry seasoned wood. Green wood, besides burning at only 60 percent of the fuel value of dry wood, deposits creosote on the inside of your stove and along the chimney. This can cause an extreme danger of chimney fire. To be called "seasoned", wood must be dried for a year. Regardless of whether the wood is green or seasoned, it should be stored in a well-sheltered, ventilated area to allow proper drying during the year to come. Wood should be stored beyond recommended clearance from combustibles.

DO NOT BURN:

Treated Wood	Solvents	Trash	Coal
Garbage	Cardboard	Colored Paper	

Instructions for First Burn - Curing the Stove Paint

Your stove has been painted with the highest quality stove paint and has special break-in procedures. The heat generated by the normal operation of the stove, will serve to harden the paint.

Ventilate the house during the first three times the stove is used. The paint on the stove will give off smoke, carbon dioxide and an odor. Without adequate ventilation, concentrations of smoke could irritate you or cause damage to person and/or property. Open doors and windows and use a fan if necessary. After the initial burns the paint will be cured and there should be no more smoke.

Each of the initial burns should be conducted as follows:

1. The first and second burns should be approximately 250° F (120° C) for approximately 20 minutes.
2. The third burn should be between 500° F (260 to 370° C) for at least 45 minutes. The important fact is the paint should be cured slowly. Avoid hot fires during the curing process.

During the curing process the paint will be gummy. Once cured the paint will remain hard.

It is normal to see flat spots on painted surfaces of the stove. The flat spots on the paint surface indicate the hotter surfaces of the stove, and is caused by the heat radiating through the paint. It is also expected that shiny spots caused by friction from the packaging materials, will disappear during the curing of the stove.

SO:

1. Remember to ventilate well.
2. Allow the stove to cure before burning for long periods at high temperatures.
3. Flat spots on the painted surfaces are normal.
4. Shiny spots on the paint surface before burning is normal.
5. Call your dealer if you have any questions.

Building a Fire

Never use gasoline, gasoline-type lantern fuel, kerosene, charcoal lighter fluid or similar liquids to start or 'freshen up' a fire in this heater. Keep all such liquids well away from the heater while it is in use.

1. Open inlet air control fully.
2. Place a small amount of crumpled paper in the stove.
3. Cover the paper with a generous amount of kindling in a teepee fashion and a few small pieces of wood.

4. Ignite the paper and close door. If fire dies down substantially, open door slightly.
5. Add larger pieces of wood as the fire progresses being careful not to overload. Do not fill firebox beyond firebrick area. An ideal coal bed of 1" to 2" should be established to achieve optimum performance.
6. This unit is designed to function most effectively when air is allowed to circulate to all areas of the firebox. An ideal means of achieving this is to rake a slight (1" to 2" wide) trough in the center of the coal bed from front to back prior to loading the fuel.
7. Once fuel has been loaded, close the door and open air inlet control fully until fire is well established (approx. 10 minutes) being careful not to overfire.
8. Readjust air inlet control to desired burn rate. If excessive smoke fills firebox, open air inlet control slightly until flames resume and wood is sufficiently ignited. While a basic rule of thumb is "closed-low", "1/2 way - medium" and "fully open-high", refer to the Inlet Air Control Settings chart.
9. When refueling, adjust air control to the fully open position. When fire brightens, slowly and carefully open the door. This procedure will prevent gases from igniting causing smoke and flame spillage.
10. Add fuel being careful not to overload.

4. Never attempt to clean the glass while unit is hot. If the deposit is not very heavy, normal glass cleaners are adequate with a plain, nonabrasive scouring pad. Heavier deposits may be removed with the use of a readily available oven cleaner.
5. Never put substances which can ignite explosively in the unit since even small explosions in confined areas can blow out the glass.
6. This unit has an airwash system, designed to reduce deposits on glass.

Replace glass only with high temperature Robax Pyroceram of the proper size and thickness.

Gasket Replacement

After extensive use, the sealing material which provides glass and door seal may need to be replaced if it fails to sustain its resilience. Inspect glass and door seal periodically to ensure for proper seal. If gaskets become frayed or worn, replace immediately.

Contact your dealer for approved replacement parts.

The following steps should be followed for glass gasket replacement:

1. Ensure appliance is not in operation and has thoroughly cooled.
2. Remove screw and glass clip.
3. Lift glass out from glass clip.
4. Remove old gasket and clean glass.
5. Replace new gasket starting at the bottom of glass working along edges, being sure to center gasket channel on glass.
6. Trim to length and butt ends together.
7. Replace glass in door, being sure not to over-tighten screw and clip.

The following steps should be followed for door gasket replacement:

1. Ensure appliance is not in operation and has thoroughly cooled.
2. Remove old door gasket and clean channel.
3. Using an approved high temperature gasket cement, apply a thin coat in bottom of channel.
4. Starting at hinge side of door, work into around door unit, and butt and trim to length.
5. Close door and allow three to four hours for cement to set before restarting appliance.

Inlet Air Control Settings				
Desired Burn Setting	Inlet Air Setting	*Approx. BTU Output		
		WR1000 Series	WR1500 Series	WR2000 Series
Low	Closed Fully	10,600	10,370	12,000
Med / Low	1/4 Open	12,118	12,420	13,400
Med / High	3/4 Open	19,413	15,676	17,700
High	Fully Open	26,100	29,301	55,100

*1. Maximum burn times and heat outputs are based on laboratory testing using full loads of seasoned hardwoods, and may vary in individual use depending on how the stove is operated, type and moisture content of fuel, and other factors. Maximum burn times are achieved under different operating conditions than are maximum heat outputs.

2. These values are based on operation in building code conforming homes under typical winter climate conditions in the northeastern US. If your home is of nonstandard construction (i.e. unusually well-insulated, built underground, or if you live in a more temperate climate), these may not apply. Since so many variables affect performance, consult your Windsor Authorized Dealer to determine realistic expectations for your home.

3. Under specific conditions used during EPA emission testing.

Glass Care

The following use and safety tips should be observed.

1. Inspect the glass regularly for cracks and breaks. If you detect a crack or break, extinguish the fire immediately and contact your dealer for replacement.
2. Do not slam door or otherwise impact the glass. When closing doors, make sure that logs or other objects do not protrude and impact the glass.
3. Do not clean the glass with materials which may scratch (or otherwise damage) the glass. Scratches on the glass can develop into cracks or breaks.

Creosote

When wood is burned slowly, it produces tar and other organic vapors. These combine with moisture to form creosote. Creosote vapors condense in the relatively cool chimney flue of a slow-burning fire. As a result, creosote residue accumulates on the flue lining. When ignited, this creosote makes an extremely hot fire. The chimney should be inspected regularly during the heating season to determine if a creosote build-up has accumulated. If this is the case, the creosote should be removed to reduce the risk of chimney fire.

Ways to Prevent and Keep Unit Free of Creosote

1. Burn with air control open for several minutes at numerous intervals throughout the day during the heating season, being careful not to over-fire unit. This removes the slight film of creosote accumulated during low burn periods.
2. Burn stove with draft control wide open for several minutes every time you apply fresh wood. This allows wood to achieve the charcoal stage faster and burns wood vapors which might otherwise be deposited within the system.
3. Burn only seasoned wood. Avoid burning wet or green wood. Seasoned wood has been dried for at least one year.
4. A small hot fire is preferable to a large smouldering one that can deposit creosote within the system.
5. Establish a routine for the fuel, wood burner and firing technique. Check daily for creosote build-up until experience shows how often you need to clean to be safe. Be aware that the hotter the fire, the less creosote is deposited. Weekly cleaning may be necessary in mild weather even though monthly cleaning may be enough in the coldest months. Contact your local municipal authority for information on how to handle a chimney fire. Have a clearly understood plan to handle a chimney fire.

WARNING: Things to remember in case of chimney fire: 1. Close draft control. 2. Call the fire department.

Ash Disposal

This unit features a convenient ash lip for easy removal of ash. During constant use, ashes should be removed every few days, or whenever ashes get to three to four inches deep in the firebox. Remove ashes only when the fire has died down and the ashes have cooled. Even then, expect to find a few hot embers.

Ashes should be placed in a metal container with a tight-fitting lid. The closed container of ashes should be placed on a noncombustible floor, well away from

all combustible materials, pending final disposal. If the ashes are disposed of by burial in soil or otherwise locally dispersed, they should be retained in the closed container until all cinders have thoroughly cooled. Other waste should not be placed in the ash can.

IMPORTANT

Helpful Hints

1. What is the correct way to start a fire?

- a. You will need small pieces of dry wood (kindling) and paper. Use only newspaper or paper that has not been coated or had unknown materials glued or applied to it. Never use coated (typically advertising flyers) or colored paper.
- b. Open the door of the wood stove.
- c. Crumple several pieces of paper and place them in the center of the firebox and directly on to the firebricks of the wood stove. Never use a grate to elevate the fire.
- d. Place small pieces of dry wood kindling) over the paper in a teepee manner. This allows for good air circulation, which is critical for good combustion.
- e. Light the crumpled paper in 2 or 3 locations:

NOTE: It is important to heat the air in the stove-pipe for draft to start.
- f. Fully open the air control of the wood stove and close the door until it is slightly open, allowing for much needed air to be introduced into the fire box. Never leave the door fully open as sparks from the kindling may occur causing injury or property damage. As the fire begins to burn the kindling, some additional kindling may be needed to sustain the fire. **DO NOT** add more paper after the fire has started.
- g. Once the kindling has started to burn, add some of the smaller pieces of seasoned (dry) firewood.

NOTE: Adding large pieces at the early stages will only serve to smother the fire. Continue adding small pieces of seasoned (dry) firewood, keeping the door slightly open until each piece starts to ignite. Remember to always open the door slowly when placing wood into the fire.
- h. Once the wood has started to ignite and the smoke has reduced, close the wood stove door fully. The reduction of smoke is a good indication that the draft in the chimney has started and good combustion is now possible. Larger pieces of seasoned (dry) firewood can now be added when there is sufficient space in the firebox. Adjust the air control setting to desired setting.
- i. **NOTE:** The lower the air control setting the longer the burn time of your firewood.

2. What type of wood is best to use as firewood?

Dry seasoned hardwood should be used. Avoid green unseasoned wood. Green wood, besides burning at only 60 percent of the fuel value of dry seasoned wood, will deposit creosote on the inside of your stove and along the inside of your chimney.

3. What does dry seasoned wood mean, and what is considered hardwood?

Wood that has been dried for a period of one year in a well-ventilated and sheltered area would be considered dry seasoned wood. Hardwoods are generally from slow growth trees (Example: Oak and fir) Softwoods are generally from fast growth trees. (Example: Pine and spruce).

4. Will following the above listed steps for starting a fire result in perfect results all the time?

The quick answer is most of the time. There are many variables that may affect your success rate when starting a fire. Most of those variables and how to deal with them will be learned through experience. Your ability to start a good fire will significantly increase with time and patience. Some of the reasons for poor stove performance will be covered next.

5. Why can't I get the fire lit?

Damp or wet wood and poor draft are the main reasons for poor results in starting a fire. Always use dry seasoned wood for your fire. Even wood dried for two years will be difficult to ignite, if it has become wet.

6. Why is there always a large quantity of thick black smoke present in the firebox?

A large quantity of thick black smoke in the firebox, is a good indication that the draft is poor.

7. Is it normal for soot to cover the glass at the beginning of a fire?

Your stove has been built with an air wash system that will help keep the glass clear when the firebox has reached a good operating temperature and has a good draft. Cold firebox temperature and poor draft cause sooting of the glass. Once the firebox temperature and the draft increases, the soot will burn off.

8. What is draft?

Draft is the ability of the chimney to exhaust draw by-products produced during the normal combustion process.

9. What can cause a poor draft?

The most common factors for poor draft are:

- a. Atmospheric pressure and air supply
- b. Environmental conditions
- c. Cold chimney temperature
- d. Poor chimney installation and maintenance

a. Atmospheric Pressure and Air Supply

Atmospheric pressure affecting the draft from a

chimney can be either outside the home, inside the home or both. Outside the home, a high-pressure day (clear and cool) generally creates a better draft in the chimney than a low-pressure day (overcast and damp). Inside the home, normal household appliances, such as clothes dryers and forced air furnaces compete for air resulting in inadequate amounts of air available to fuel a fire and create a condition known as negative pressure. Under extreme conditions of negative pressure the combustion by-products can be drawn from the chimney and into the house. This condition is commonly referred to as down drafting. There are several factors that impact the amount of air available in the home. Increased amounts of insulation vinyl windows, extra caulking in various places and door seals can all keep heat in but may also make a home too airtight. If you are in doubt about whether or not there is sufficient air in your home for your stove, curtain using those appliances known to consume the air where possible, or open a window or door to allow air to enter the home.

b. Environmental Conditions

High trees, low lying house location such as in a valley, tall buildings or structures surrounding your house and windy conditions can cause poor draft or down drafting.

c. Cold Chimney Temperature

Avoid cold chimney temperatures by burning a hot fire for the first fifteen to forty minutes, being careful not to over fire. If any part of the chimney or parts of the stove start to glow, you are over firing the stove. Where possible, install a temperature gauge on the chimney so temperature drops can be seen.

d. Chimney Installation and Maintenance

Avoid using too many elbows or long horizontal runs. If in doubt, contact a chimney expert and/or chimney manufacturer for help. Clean chimney, rain caps and especially spark arrester regularly, to prevent creosote build up, which will significantly reduce chimney draw and may cause a chimney fire.

10. Should I close or open the air control fully when shutting down the stove?

When shutting down the stove, fully open the air control. This allows the chimney temperatures to remain as high as possible for as long as possible. Cold chimney temperatures create creosote.

NOTE: This instruction is intended as an aid and does not supersede any local, provincial or state requirements. Check with officials or authorities having jurisdiction in your area.

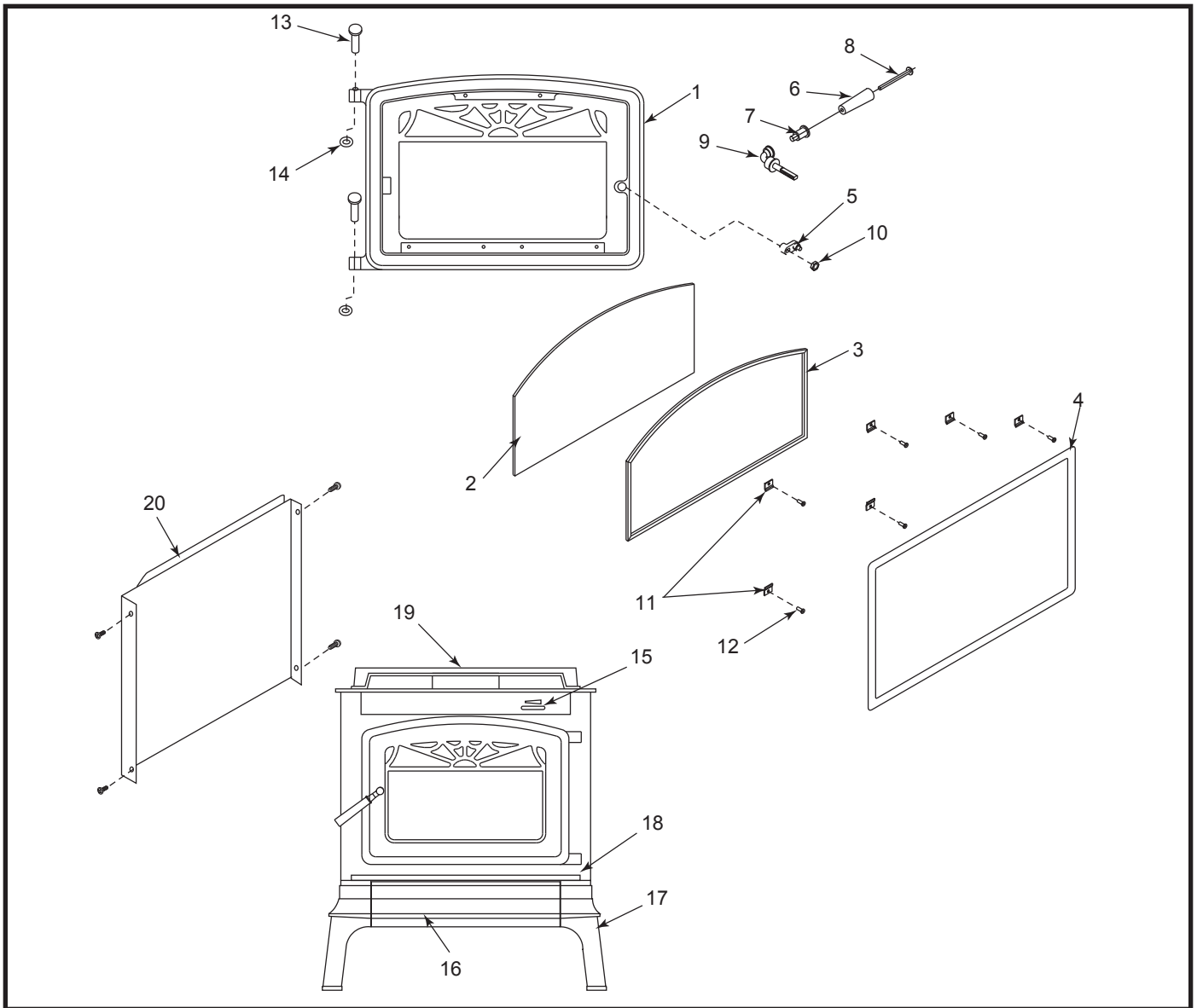

MHSC reserves the right to make changes in design, materials, specifications, prices and discontinue colors and products at any time, without notice.

WR1000 Series, WR1500 Series, WR2000 Series Wood Stoves

Item	Description	Qty.	WR1000	WR1500	WR2000
1.	Door Casting - Black	1	30005132	S12071	S12071
2.	Glass Gasket	1	S31117	S31141	S31141
3.	1/8" (3 mm) Glass Gasket x 6'	1	S15001-6	S15001-6	S15001-6
4.	5/8" (16 mm) Door Gasket x 6'	1	S15011-6	S15011-6	S15011-6
5.	Pawl Assembly	1	30002362	30002362	30002362
6.	Handle - Black	1	1600664	1600664	1600664
7.	Insert - Lifter Handle - Nickel	1	1600650	1600650	1600650
8.	Screw 1/4 x 3 3/8"	1	1201310	1201310	1201310
9.	Handle Assembly	1	5004245	5004245	5004245
10.	Lock Nut	1	1203290	1203290	1203290
11.	Glass Clips	7	S37034	S37034	S37034
12.	Screw #10 x 1/2	7	S11086	S11086	S11086
13.	Hinge Pin	2	S11005	S11005	S11005
14.	3/8 Retaining Ring	2	S11090	S11090	S11090

WR1000 Series, WR1500 Series, WR2000 Series Wood Stoves (continued)

Item	Description	Qty.	WR1000	WR1500	WR2000
15.	1/4" Spring Handle	1	90000070	90000070	90000070
16.	Ash Drawer	1	S31333	S31333	S31336
17.	Leg Casting	2	S25076	S25080	S25084
18.	Ashfender	1	S25077	S25082	S25082
19.	Airmate	1	S25088	S25092	S25093
20.	Removable Rear Heat Shield	1	90000037	90000038	S29265

NOTE: Refer to Page 6 for fire brick replacement.

Limited Lifetime Warranty

Limited Three Year Warranty

MHSC (hereafter referred to as the "company") warrants that your new Windsor brand wood burning plate steel stove or masonry wood insert is free from manufacturing and material defects for a period of three years from the date of sale, subject to the following conditions and limitations.

Limited One Year Warranty

Electrical components such as blowers and speed controls are covered for one year only. Glass door panels are covered for thermal breakage only. To clean glass, use a ceramic glass cleaner or polish. Do not use ammonia-based cleaners. A suitable cleaner is available from your nearest Hearth Products dealer. **DO NOT CLEAN GLASS WHILE HOT AND DO NOT USE ABRASIVE CLEANERS.**

Excluded from Warranty

Brass parts should be cleaned with soap and warm water and immediately dried. Brass parts may also be damaged by external chemicals. Gold and any other plated parts will not be covered under this warranty. Plated surfaces should be cleaned by using denatured alcohol only and rubbed lightly with a lint-free non-abrasive cloth. Excessive rubbing or polishing may remove the plated finish. Discoloration of certain parts is normal and is not a defect, and therefore not covered under warranty.

This warranty will not include or extend to paint, gaskets, baffles or firebrick components, and does not cover any removable firebox components such as brick retainers or stainless steel air tubes.

Extended Limited Lifetime Warranty

The company offers a limited lifetime warranty on the firebox (welds only), castings and ash drawers on any of Windsor wood burning products. The limited lifetime warranty is extended to the original owner only, and is subject to proof of purchase by the original owner and residential use.

1. The new product must be installed and operated at all times in accordance with the installation and operation instructions supplied with the appliance, and installation must be to local and national codes. Any alterations, willful abuse, accident, over firing or misuse will not be covered under warranty. NOTE: Some minor movement of certain parts is normal and is not a defect and therefore, not covered under warranty.
2. The warranty is non-transferable, and is made to the original owner, provided that the purchase was made through an authorized MHSC supplier. The serial number must be supplied along with the Bill of Sale, showing the date of purchase, at the time the claim is submitted.
3. This warranty is limited to the repair or replacement of parts only and is applicable only to those parts found to be defective in material or construction that have been subjected to normal conditions of use and service. All defects must be confirmed by the company or an authorized representative. If requested by the company, defective parts must be shipped back transportation prepaid, to the company. Credits will be issued upon receipt of return of the defective product to the company.
4. The company, at its discretion, can fully discharge all obligation with respect to this warranty by refunding the wholesale price of the defective part(s).

5. Any installation, labor, construction, transportation or other related costs or expenses arising from defective parts, repair, replacement or otherwise of same, will not be covered by this warranty, nor will the company assume responsibility for same. Further, the company will not be responsible for any incidental, indirect or consequent damages, except as provided by law, and in no event shall they exceed the original purchase price.
6. All other warranties - expressed or implied - with respect to the product, its components and accessories, or any obligations /liabilities on the part of the company are hereby expressly excluded.
7. MHSC neither assumes, nor authorizes any third party to assume, on MHSC's behalf, any other liabilities with respect to the sale of this MHSC product.
8. The warranties as outlined within this document do not apply to chimney components or other products made by other manufacturers when used in conjunction with the installation of this product. Improper use or the use of non-approved components may nullify your warranty. If in doubt, contact your nearest authorized MHSC supplier or MHSC Customer Service Department.
9. MHSC will not be responsible for:
 - Down drafts or spillage caused by environmental conditions such as near-by trees, buildings, rooftops, hills, mountains or ineffective chimney design.
 - Inadequate ventilation, excessive offsets or negative air pressure caused by mechanical systems such as furnaces, clothes dryers, fans, etc.
10. This warranty is void if:
 - The appliance has been operated in atmospheres contaminated by chlorine, fluorine, or other damaging chemicals.
 - This appliance has been subjected to prolonged periods of dampness or condensation.
 - The appliance has any damage due to water, or weather damage that is the result of, but not limited to, improper chimney/venting installation.
 - The appliance has been subjected to willful or accidental abuse or misuse.
 - Corrosive driftwood, manufactured logs or other fuels are used other than as outlined in the installation and operating instructions.
 - The appliance is not maintained in good condition, including firebrick and gaskets.

IF WARRANTY SERVICE IS REQUIRED

Contact MHSC Customer Service. Make sure you have your sales receipt and the model/serial number of your MHSC product.

Do not attempt to do any service work yourself, unless pre-approved by MHSC in writing this will void the warranty.

MHSC must authorize service and provide a Warranty Claim Number prior to any warranty related service calls. Without an authorization number, any service work will not be deemed warranty.

NOTE: Some states and provinces do not allow the exclusion or limitation of incidental or consequential damages. The above limitation may not apply to you.

MHSC
149 Cleveland Drive
Paris, KY 40361

KEEP THIS WARRANTY

Serial # _____ Model # _____

Date Purchased _____