

S/M No. : R1B4H0A002

DAEWOO

Service Manual

Microwave Oven

Model: **KOR-1B4H0A**

KOR-1B4H9A04



DAEWOO ELECTRONICS CO., LTD.

[http : //svc.dwe.co.kr](http://svc.dwe.co.kr)

Mar. 2002

PRECAUTIONS TO BE OBSERVED BEFORE AND DURING SERVICING TO AVOID POSSIBLE EXPOSURE TO EXCESSIVE MICROWAVE ENERGY

- (a) Do not operate or allow the oven to be operated with the door open.
- (b) Make the following safety checks on all ovens to be serviced before activating the magnetron or other microwave source, and make repairs if necessary: (1) Interlock operation, (2) Proper door closing, (3) Seal and sealing surfaces (arcing, wear, and other damage), (4) Damage to or loosening of hinges and latches (5) Evidence of dropping or abuse.
- (c) Before turning on power to the microwave oven for any service test or inspection within the microwave generating compartments, check the magnetron, wave guide or transmission line, and cavity for proper alignment, integrity, and connections.
- (d) Any defective or misadjusted components in the interlock, monitor, door seal and microwave generation and transmission systems shall be repaired, replaced, or adjusted by procedures described in this manual before the oven is released to the owner.
- (e) A microwave leakage check to verify compliance with the Federal performance standard should be performed on each oven prior to release to the owner.

TABLE OF CONTENTS

SAFETY AND PRECAUTIONS	3
FOR SAFE OPERATION.....	3
FOR SAFE SERVICE PROCEDURES	3
SPECIFICATIONS	4
EXTERNAL VIEW	5
OUTER DIMENSION	5
FEATURE DIAGRAM.....	6
CONTROL PANEL.....	7
INSTALLATION	8
OPERATIONS AND FUNCTIONS	9
DISASSEMBLY AND ASSEMBLY	10
INTERLOCK MECHANISM AND ADJUSTMENT	17
TROUBLE SHOOTING GUIDE	18
MESUREMENT AND TEST	22
MEASUREMENT OF THE MICROWAVE POWER OUTPUT.....	22
MICROWAVE RADIATION TEST	23
COMPONENT TEST PROCEDURE	24
WIRING DIAGRAM	25
PRINTED CIRCUIT BOARD	27
CIRCUIT CHECK PROCEDURE.....	27
PCB CIRCUIT DIAGRAM	30
P.C.B. LOCATION NO.	31
EXPLODED VIEW AND PARTS LIST	32
DOOR ASSEMBLY	32
CONTROL PANEL ASSEMBLY	32
TOTAL ASSEMBLY	32

SAFETY AND PRECAUTIONS

CAUTION : This Device is to be Serviced Only by Properly Qualified Service Personnel. Consult the Service Manual for Proper Service Procedures to Assure Continued Safety Operation and for Precautions to be Taken to Avoid Possible Exposure to Excessive Microwave Energy.

1. FOR SAFE OPERATION

Damage that allows the microwave energy (that cooks or heats the food) to escape will result in poor cooking and may cause serious bodily injury to the operator.

IF ANY OF THE FOLLOWING CONDITIONS EXIST, OPERATOR MUST NOT USE THE APPLIANCE.

(Only a trained service personnel should make repairs.)

- 1) A broken door hinge.
- 2) A broken door viewing screen.
- 3) A broken front panel, oven cavity.
- 4) A loosened door lock.
- 5) A broken door lock.

The door gasket plate and oven cavity surface should be kept clean.

No grease, soil or spatter should be allowed to build up on these surfaces or inside the oven.

DO NOT ATTEMPT TO OPERATE THIS APPLIANCE WITH THE DOOR OPEN. The microwave oven has concealed switches to make sure the power is turned off when the door is opened. Do not attempt to defeat them.

DO NOT ATTEMPT TO SERVICE THIS APPLIANCE UNTIL YOU HAVE READ THIS SERVICE MANUAL.

2. FOR SAFE SERVICE PROCEDURES

- 1) If the oven is operative prior to servicing, a microwave emission check should be performed prior to servicing the oven.
- 2) If any certified oven unit is found to servicing, a microwave emission check should be performed prior to servicing the oven.
 - (a) inform the manufacturer, importer or assembler,
 - (b) repair the unit at no cost to the owner,
 - (c) attempt to ascertain the cause of the excessive leakage,
 - (d) tell the owner of the unit not to use the unit until the oven has been brought into compliance.
- 3) If the oven operates with the door open, the service person should tell the user not to operate the oven and contact the manufacturer and CDRH immediately.

CAUTION

MICROWAVE RADIATION

PERSONNEL SHOULD NOT BE EXPOSED TO THE MICROWAVE ENERGY WHICH MAY RADIATE FROM THE MAGNETRON OR OTHER MICROWAVE GENERATING DEVICE IF IT IS IMPROPERLY USED OR CONNECTED. ALL INPUT AND OUTPUT MICROWAVE CONNECTIONS, WAVEGUIDES FLANGES AND GASKETS MUST BE SECURED. NEVER OPERATE THE DEVICE WITHOUT A MICROWAVE ENERGY ABSORBING LOAD ATTACHED. NEVER LOOK INTO AN OPEN WAVEGUIDE OR ANTENNA WHILE THE DEVICE IS ENERGIZED.

SPECIFICATIONS

MODEL		KOR-1B4H0A	KOR-1B4H9A04
POWER SUPPLY		120V~60HZ, SINGLE PHASE WITH EARTHING	
POWER CONSUMPTION	MICROWAVE	1500 W	1400 W
	GRILL		
	COMBINATION		
MICROWAVE ENERGY OUTPUT		1100 W	1000W
MICROWAVE FREQUENCY		2450MHz	
OUTSIDE DIMENSIONS (W X H X D)		560X344X471mm (22.0X13.5X18.5 in.)	
CAVITY DIMENSIONS (W X H X D)		369X246X394mm (14.5X9.7X15.5 in.)	
NET WEIGHT		APPROX. 16.7kg	
TIMER		99min. 99sec.	
FUNCTION SELECTIONS		MICROWAVE	
POWER SELECTIONS		10 LEVELS	
CAVITY VOLUME		1.3 Cu. Ft	

* Specifications are subject to change without notice.

EXTERNAL VIEW

1. OUTER DIMENSION

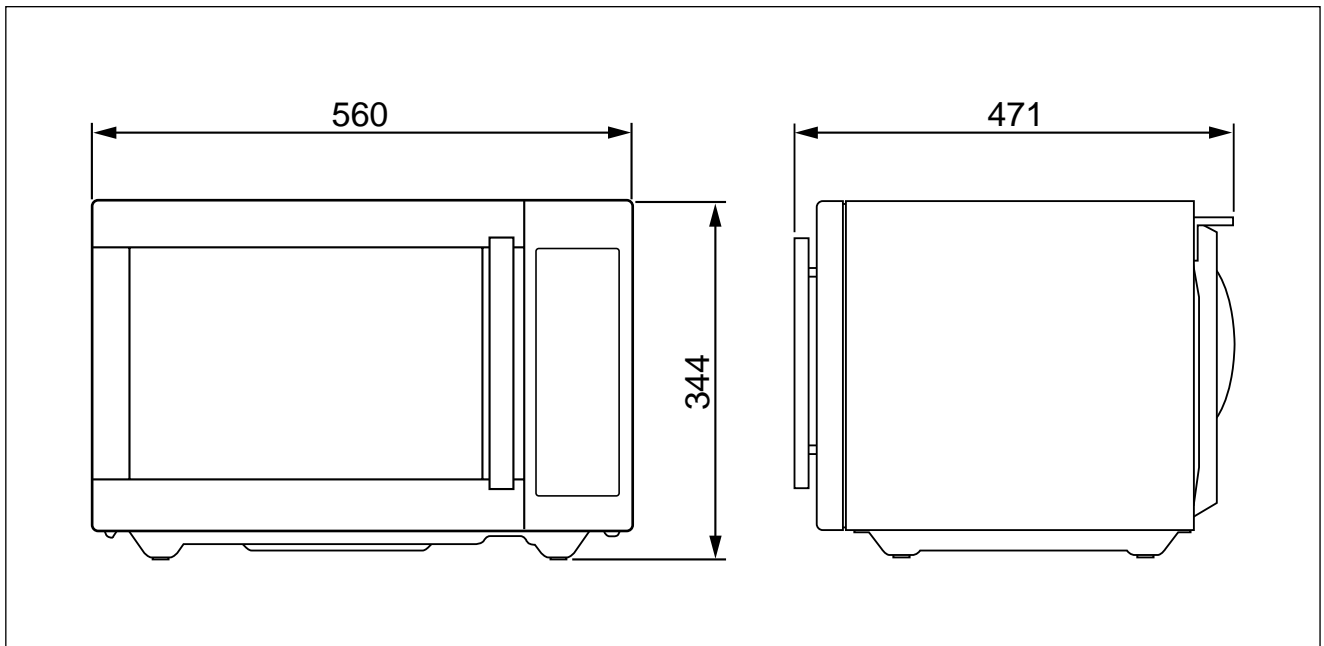

2. FEATURE DIAGRAM

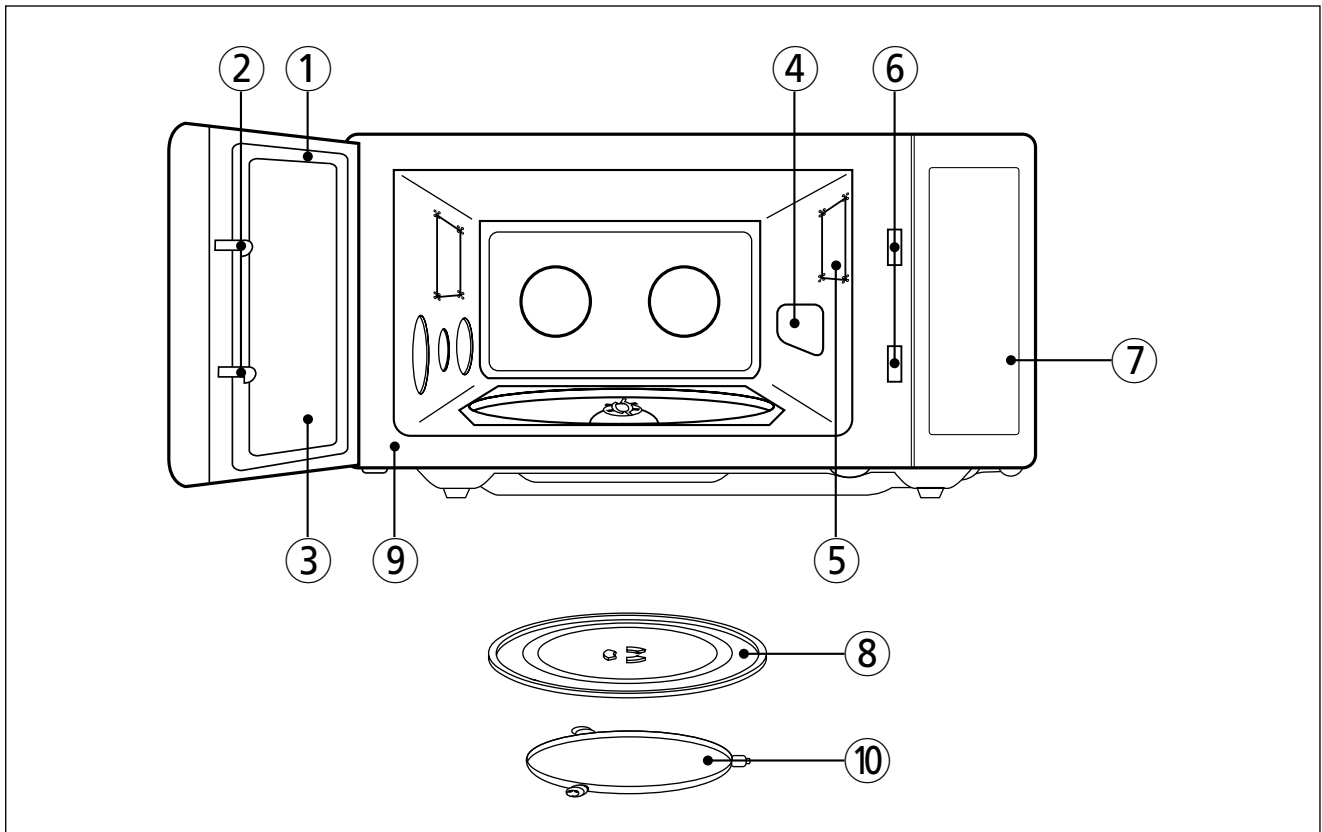

1. DOOR SEAL

Door seal maintains the microwave within the oven cavity and prevents microwave leakage.

2. DOOR HOOK

When door is closed, it will automatically lock shut. If door is opened while oven is operating, magnetron tube will immediately stop operating.

3. DOOR SCREEN

Allows viewing of food. Microwave cannot pass through perforations in screen.

4. SPATTER SHIELD

Protects the microwave outlet from splashes of cooking foods.

5. OVEN LAMP

Automatically turns on during oven operating.

6. SAFETY INTERLOCK SYSTEM

7. CONTROL PANEL

8. GLASS COOKING TRAY

Made of special heat resistant glass. The tray must always be in proper position before operating. Do not cook food directly on the tray.

9. OVEN FRONT PLATE

10. ROLLER GUIDE

Supports the glass cooking tray.

3. CONTROL PANEL

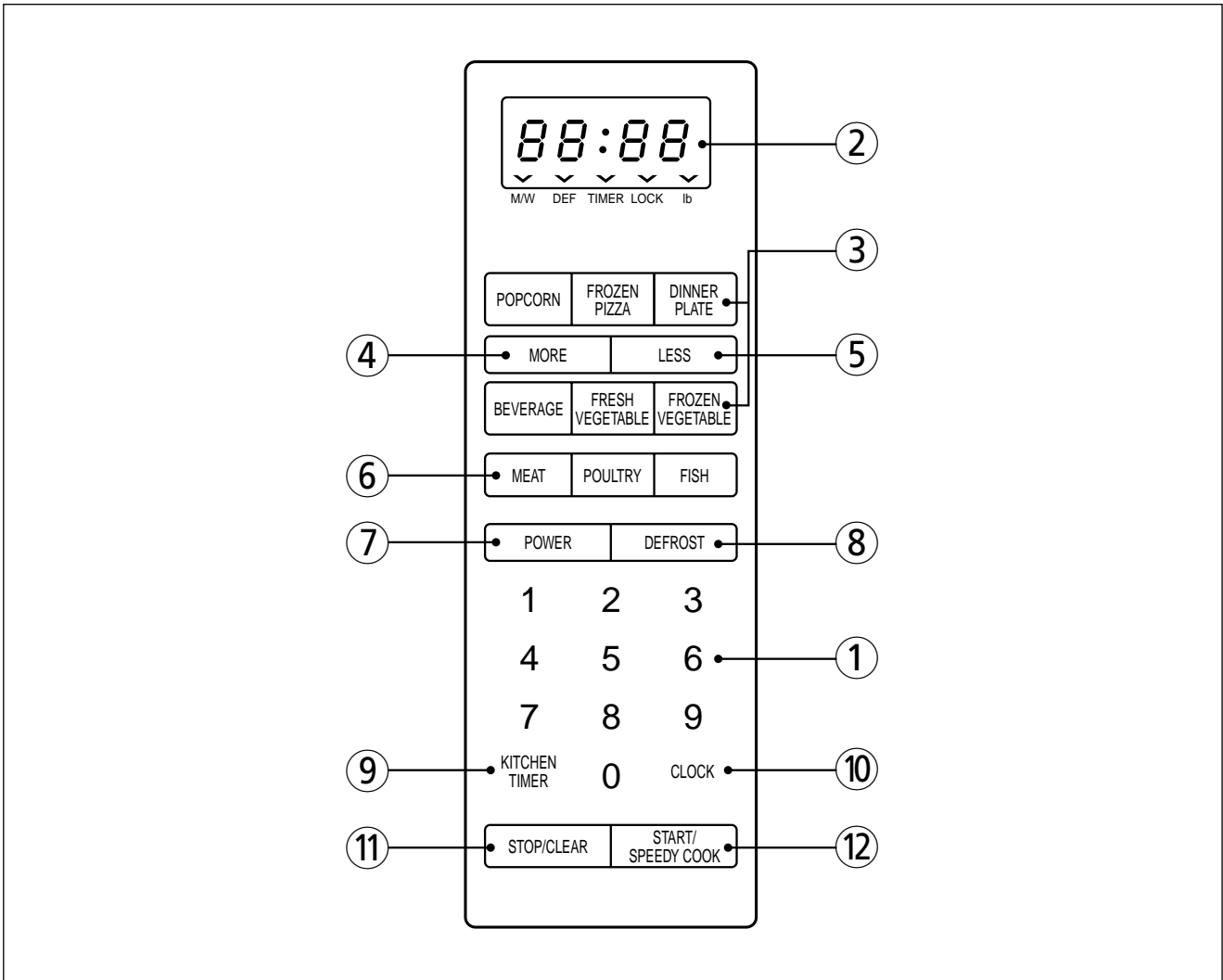

1. **Time set pad** - Used to set the cooking time and the present time.
2. **Display** - Cooking time, power level, indicators and present time are displayed.
3. **One touch** - Used to cook or reheat specific quantities of food.
4. **More** - Used to add time to cooking.
5. **Less** - Used to remove time from cooking.
6. **Auto Defrost** - Used to defrost foods.(for weight)
7. **Power** - Used to set power level.
8. **Defrost** - Used to defrost foods.(for time)
9. **Kitchen Timer** - Used as a minute timer, delay cooking, hold setting after cooking.
10. **Clock** - Used to set clock.
11. **Stop/Clear** - Used to stop the oven operation or to delete the cooking data.
12. **Start/Easy cook** - Used to start the oven and also used to set a reheat time.

INSTALLATION

1. Steady, flat location.

This microwave oven should be set on a steady, flat surface.

2. Leave space behind and side.

All air vents should be kept a clearance. If all vents are covered during operation, the oven may be overheated and, eventually, cause oven failure.

3. Away from radio, and TV sets

Poor television reception and radio interference may result if the oven is located close to a TV, radio, antenna, or feeder and so on. Position the oven as far from them as possible.

4. Away from heating appliances and water taps

Keep the oven away from hot air, steam or splash when choosing a place to position it, or the insulation might be adversely affected and breakdowns occur.

5. Power supply

- Check your local power source.

This microwave oven requires a current of approximately 15 amperes, 120Volts, 60Hz grounded outlet.

1. A short power-supply cord is provided to reduce the risks resulting from becoming entangled in or tripping over a longer cord.
2. Longer cord sets or extension cords are available and may be used if care is exercised in their use.
3. If a long cord or extension cord is used:
 - 1) The marked electrical rating of the cord set or extension cord should be at least as great as the electrical rating of the appliance.
 - 2) The extension cord must be a grounding type 3-wire cord.
 - 3) The longer cord should be arranged so that it will not drape over the counter top or tabletop where it can be pulled on by children or tripped over unintentionally.

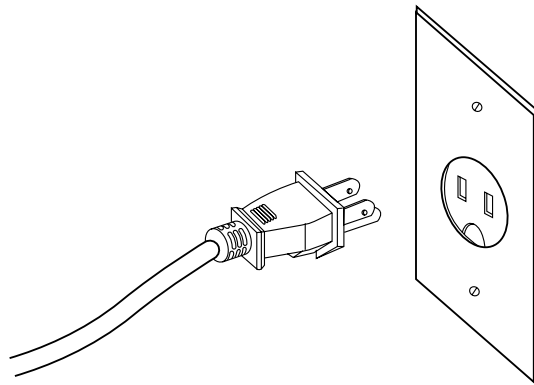

6. Examine the oven after unpacking for any damage such as:

A misaligned door, broken door or a dent in cavity.

If any of the above are visible, DO NOT INSTALL, and notify dealer immediately.

OPERATIONS AND FUNCTIONS

1. Connect the main lead to an electrical outlet.
2. After placing the food in a suitable container, open the oven door and put it on the glass tray. The glass tray must always be in place during cooking.
3. Close the door securely.
4. The oven door can be opened at any time during operation by touching the door release button on the control panel.
The oven will automatically shut off. To restart the oven, close the door and then touch START.
5. Each time a pad is touched, a BEEP will sound to acknowledge the touch.
6. The oven automatically cook on full power unless set to a lower power level.
7. The display will show : 0 when the oven is plugged in.
8. Time clock returns to the present time when the cooking time ends.
9. When the STOP/CLEAR pad is touched during the oven operation, the oven stops cooking and all information retained.
To erase all information (except the present time), touch the STOP/CLEAR pad once more. If the oven door is opened during the oven operation, all information is retained.
10. If the START pad is touched and the oven does not operate, check the area between the door and door is closed securely. The oven will not start cooking until the door is completely closed or the program has been reset.

Make sure the oven is properly installed and plugged into the electrical outlet.

Wattage output chart

The power level is set by touching the POWER pad. The chart shows the display, the power level and the percentage

Touch POWER pad.	Power level(Display)	Approximate Percentage of Power
Once	P-HI	100%
Twice	P-90	90%
3 times	P-80	80%
4 times	P-70	70%
5 times	P-60	60%
6 times	P-50	50%
7 times	P-40	40%
8 times	P-30	30%
9 times	P-20	20%
10 times	P-10	10%
11 times	P-00	0%

DISASSEMBLY AND ASSEMBLY

- Cautions to be observed when trouble shooting.

Unlike many other appliances, the microwave oven is high-voltage, high-current equipment. It is completely safe during normal operation. However, carelessness in servicing the oven can result in an electric shock or possible danger from a short circuit. You are asked to observe the following precautions carefully.

1. Always remove the power plug from the outlet before servicing.
2. Use an insulated screwdriver and wear rubber gloves when servicing the high voltage side.
3. Discharge the high voltage capacitor before touching any oven components or wiring.

(1) Check the grounding.

Do not operate on a two-wire extension cord.

The microwave oven is designed to be used while grounded.

It is imperative, therefore, to make sure it is grounded properly before beginning repair work.

(2) Warning about the electric charge in the high voltage capacitor.

For about 30 seconds after the operation has stopped, electric charge remains in the high voltage capacitor.

When replacing or checking parts, short between oven chassis and the negative high terminal of the high voltage capacitor by using a properly insulated screwdriver to discharge.

4. When the 20A fuse is blown due to the operation of the monitor switch; replace primary interlock switch, secondary interlock switch and interlock monitor switch.
5. After repair or replacement of parts, make sure that the screws are properly tightened, and all electrical connections are tightened.
6. Do not operate without cabinet.

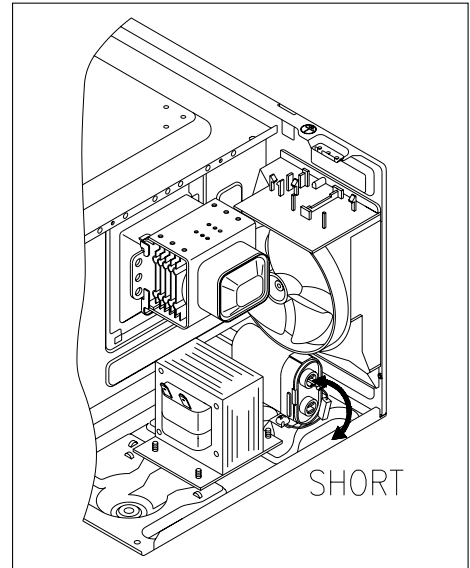

CAUTION : Service personnel should remove their watches whenever working close to or replacing the magnetron.

WARNING : When servicing the appliance, take care when touching or replacing high potential parts because of electrical shock or exposing microwave. These parts are as follows - HV Transformer, Magnetron, HV Capacitor.

1. To remove cabinet

- 1) Remove three screws on cabinet back.
- 2) Push the cabinet backward.

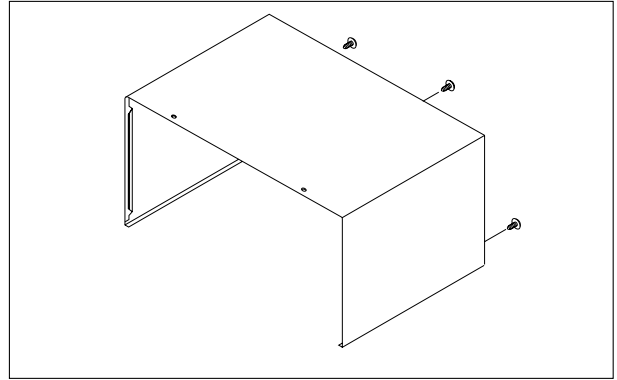

2. To remove door assembly

- 1) Remove two screws which secure the stopper hinge top.
- 2) Remove the door assembly from top plate of cavity.
- 3) Reverse the above for reassembly.

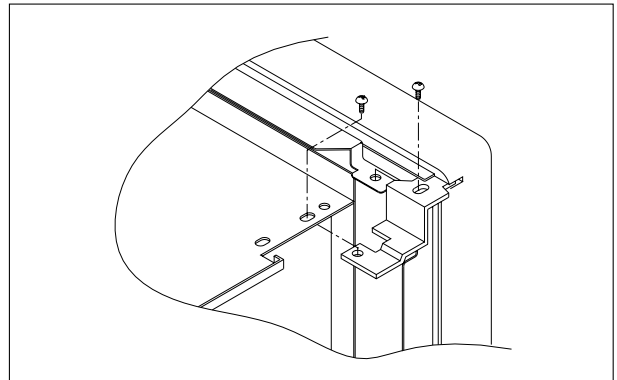

NOTE : After replacing the door assembly, perform a check of correct alignment with the hinge and cavity front plate.

3. To remove door parts.

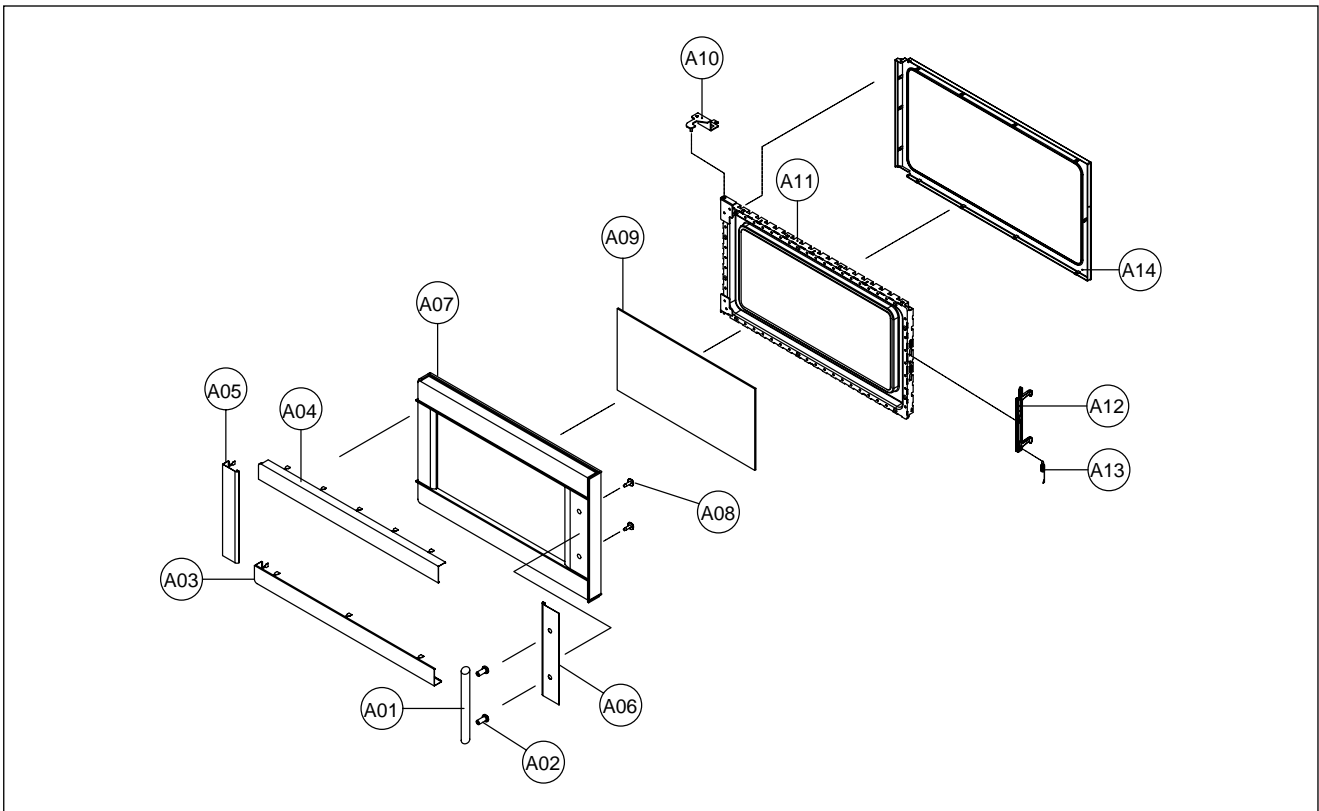

REF NO.	PART CODE	PART NAME	DESCRIPTION	Q'TY	REMARK
A01	3512604200	HANDLE DOOR	ALUMINUM	1	
A02	3515307400	SUPPORTER HANDLE	KOC-1B4K0S	2	
A03	3511605510	DECORATOR DOOR *U	STS304 T0.5	1	
A04	3511605400	DECORATOR DOOR *T	STS304 T0.5	1	
A05	3511605700	DECORATOR DOOR *L	STS304 T0.5	1	
A06	3511605600	DECORATOR DOOR *R	STS304 T0.5	1	
A07	3512204750	FRAME DOOR	ABS	1	
A08	7001503511	SCREW MACHINE	PAN 5X35 MFZN	2	
A09	3517004090	BARRIER-SCREEN *O	TEMP GLASS T3.2	1	
A10	3515204900	STOPPER HINGE *T AS	KOC-1B4K0S	1	
A11	3516602100	DOOR-PLATE	SBHG-1A T0.7	1	
A12	3513101200	HOOK	POM	1	
A13	3515101800	SPRING HOOK	PW1	1	
A14	3512302310	GASKET DOOR	PP	1	

- (1) Remove the gasket door(A14) from door plate.
- (2) Remove two screws(A08) from door plate.
- (3) Remove the door handle (A01) and handle supporter (A02) from door plate.
- (4) Remove the four door decorators (A03~A06) from door frame.
- (5) Remove the door frame (A07) from door plate.
- (6) Remove the stopper hinge top(A10) from door plate.
- (7) Remove the spring(A13) and the hook(A12).
- (8) Remove the barrier screen outer(A09) from door frame.
- (9) Reverse the above steps for reassembly.

4. Method to reduce the gap between the door seal and the oven front surface.

(1) To reduce gap located on part 'A'.

- Loosen two screws on stopper hinge top, and then push the door to contact the door seal to oven front surface.
- Tighten two screws.

(2) To reduce gap located on part 'B'.

- Loosen two screws on stopper hinge under, and then push the door to contact the door seal to oven front surface.
- Tighten two screws.

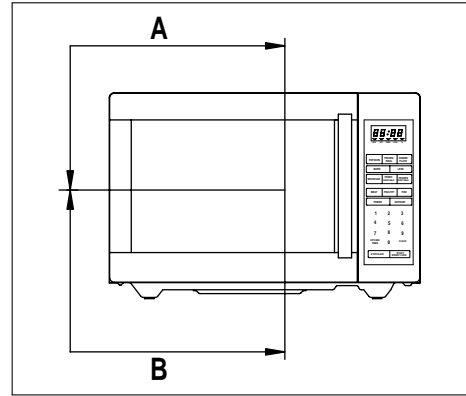

NOTE : A small gap may be acceptable if the microwave leakage does not exceed $4\text{mW}/\text{cm}^2$.

5. To remove control panel parts.

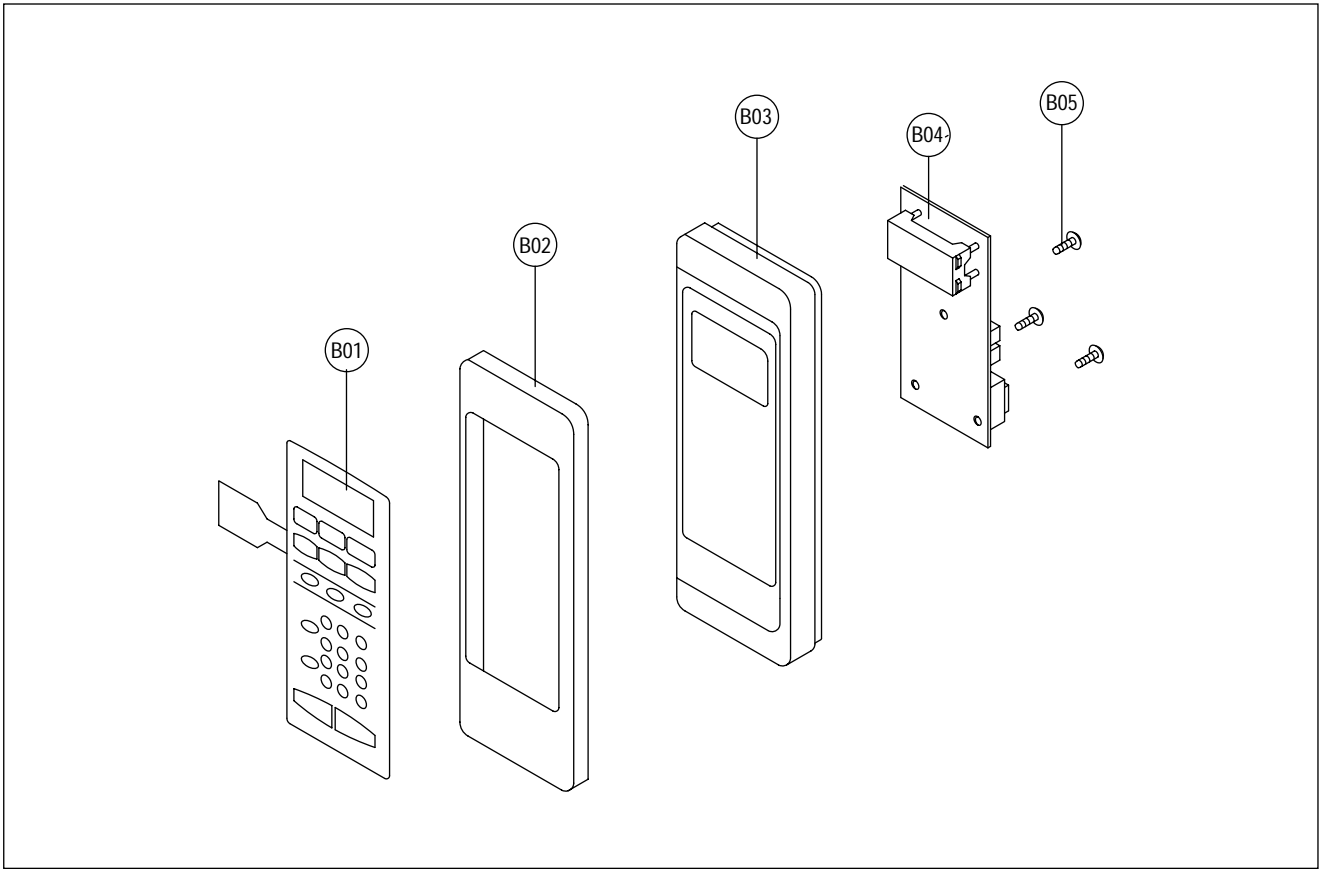

REF NO.	PART CODE	PART NAME	DESCRIPTION	Q'TY	REMARK
B01	3518523400	SWITCH MEMBRANE	KOR-1B4H0A	1	
B02	3511607600	DECORATOR C-PANEL	STS430 HL T0.5	1	
B03	3516727000	CONTROL PANEL	ABS AF-348, VT-0826	1	
B04	3514326500	PCB AS	KOR-1B4H0A	1	
B05	7122401211	SCREW TAPPING	T2S TRS 4X12 MFZN	4	

- (1) Remove the screw which secure the control panel, push up two snap fits and draw forward the control panel assembly.
- (2) Remove four screws which secure the PCB assembly to control panel.
- (3) Disconnect membrane tail from the connector of the PCB assembly.
- (4) Detach membrane from the control panel.
- (5) Pull out the decorator c-panel from the control panel.
- (6) Reverse the above steps for reassembly.

6. To remove high voltage capacitor.

- 1) Remove a screw which secure the grounding ring terminal of the H.V. diode and the capacitor holder.
- 2) Remove the H.V. diode from the capacitor holder.
- 3) Reverse the above steps for reassembly.

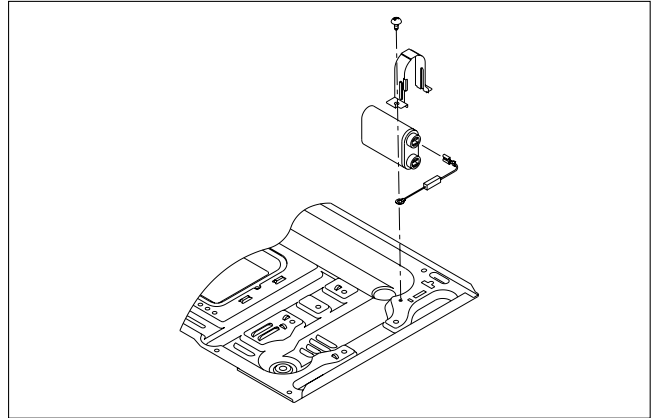

◆ High voltage circuit wiring

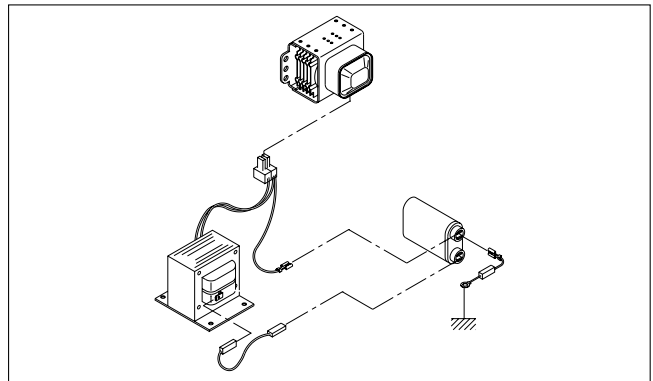

7. To remove magnetron.

- 1) Remove a screw which secure the magnetron.
- 2) Remove the magnetron.
- 3) Reverse the above steps for reassembly.

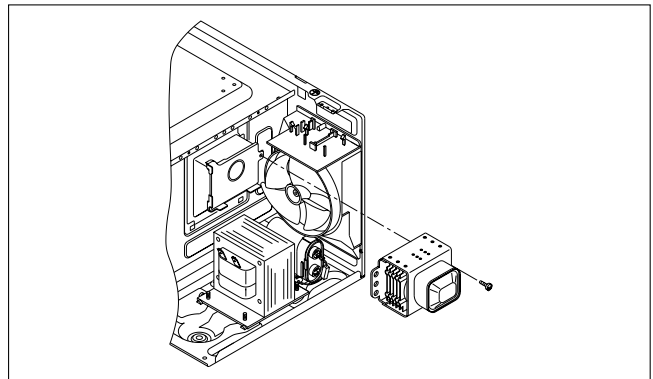

NOTE : Never install the magnetron without the metallic gasket plate which is packed with each magnetron to prevent microwave leakage. Whenever repair work is carried out on magnetron, check the microwave leakage. It shall not exceed $4\text{mW}/\text{cm}^2$ for a fully assembled oven with door normally closed.

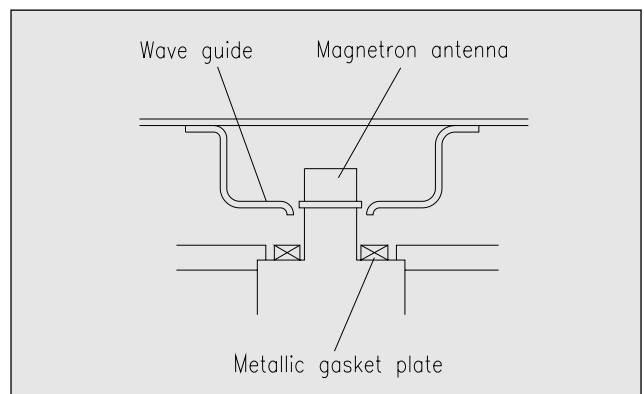
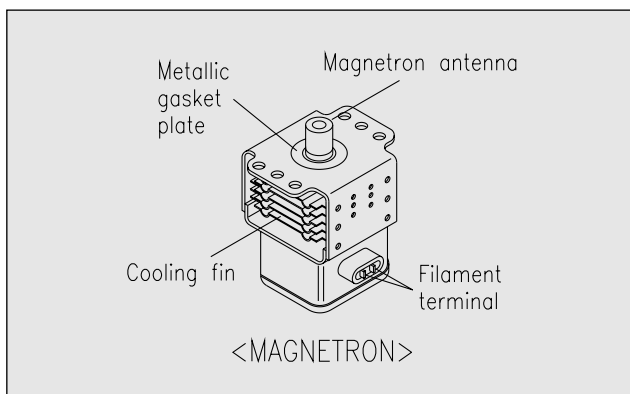

8. To remove wind guide assembly.

- 1) Remove a screw which secure the wind guide assembly.
- 2) Draw forward the wind guide assembly.
- 3) Pull the fan from the motor shaft.
- 4) Remove two screws which secure the motor shaded pole.
- 5) Remove the motor shaded pole.
- 6) Reverse the above steps for reassembly.

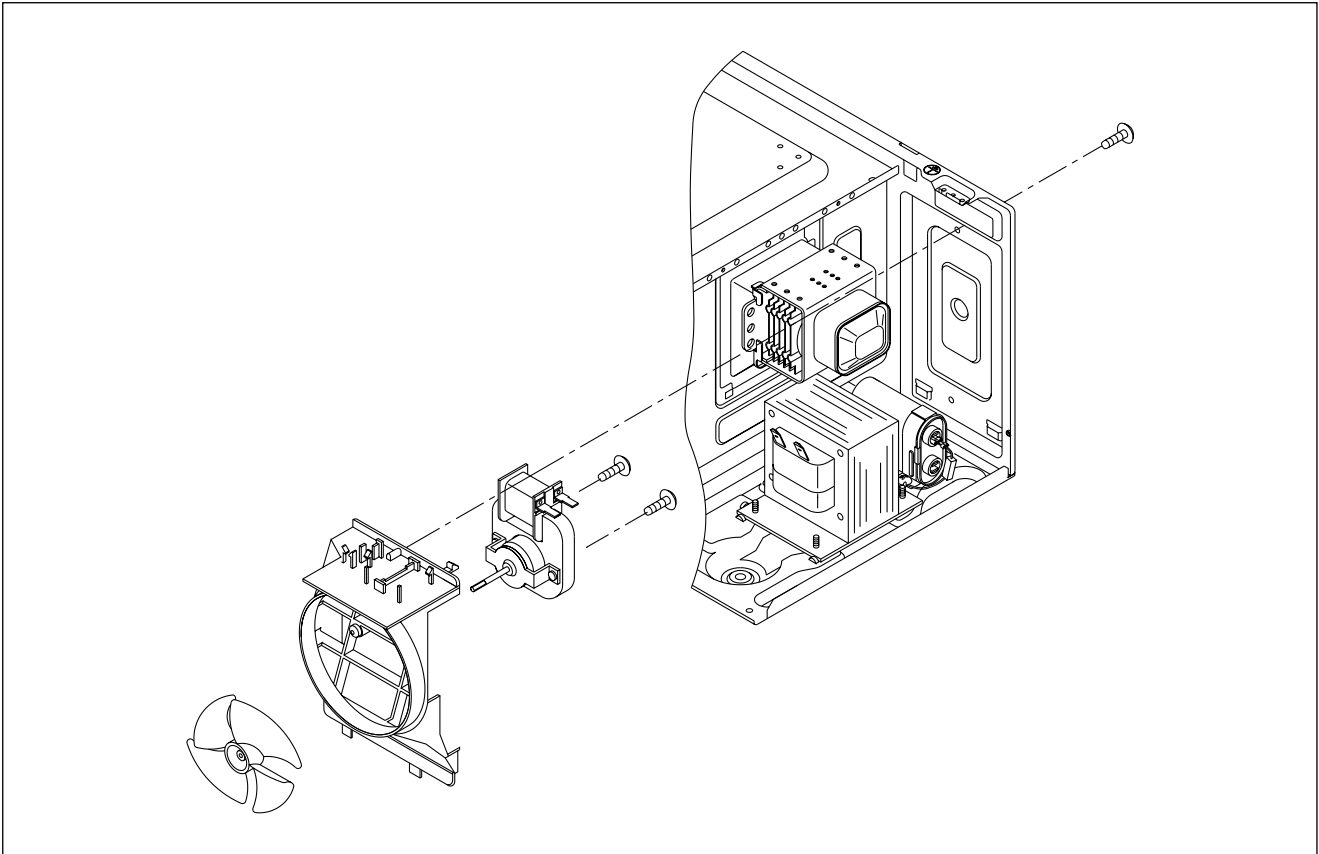

9. To remove H.V.transformer.

- 1) Remove four screws holding the H.V.transformer.
- 2) Remove the H.V.transformer.
- 3) Reverse the above steps for reassembly.

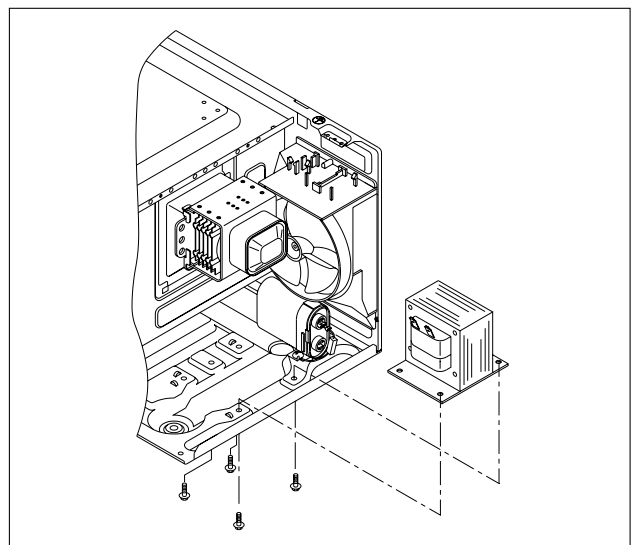

INTERLOCK MECHANISM AND ADJUSTMENT

The door lock mechanism is a device which has been specially designed to completely eliminate microwave radiation when the door is opened during operation, and thus to perfectly prevent the danger resulting from the leakage of microwave.

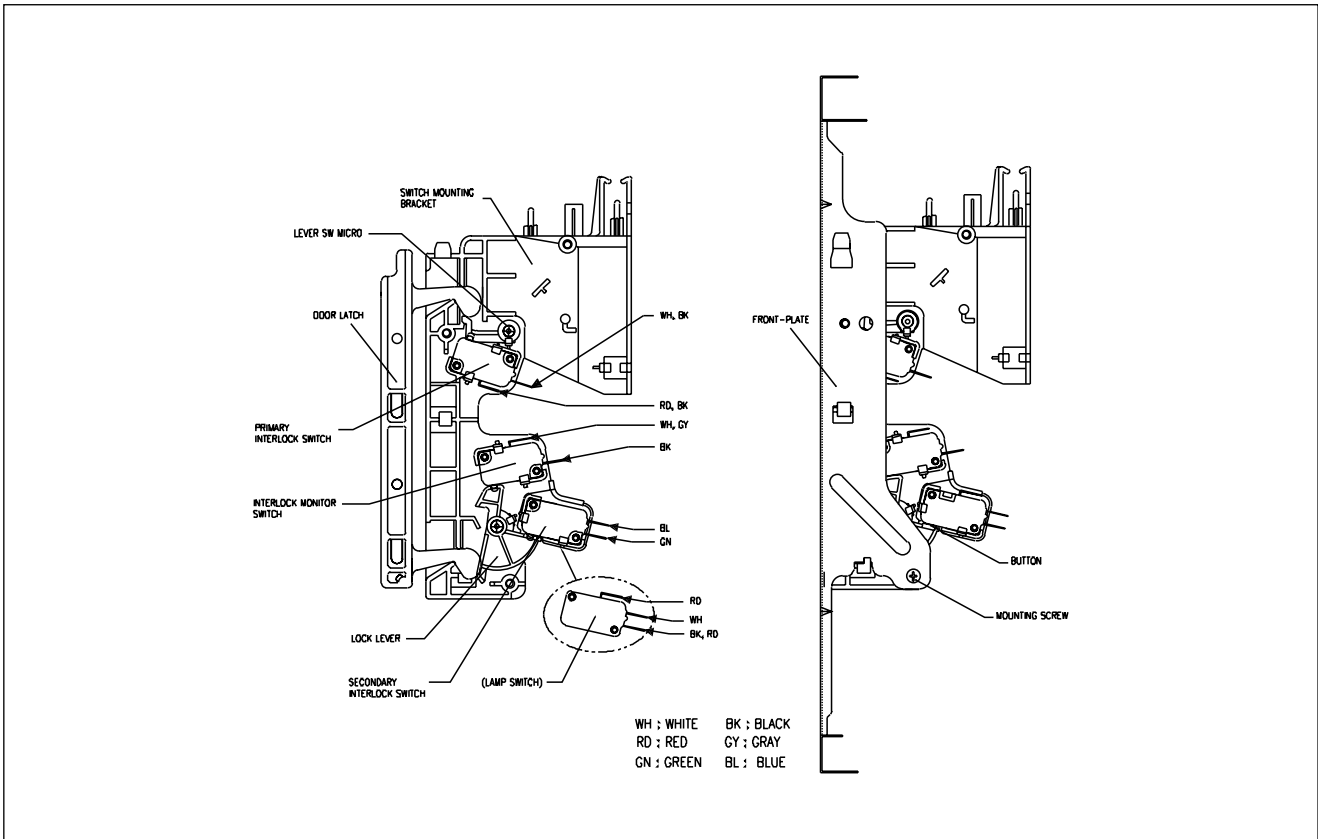

(1) Primary interlock switch

When the door is closed, the hook locks the oven door. If the door is not closed properly, the oven will not operate.

When the door is closed, the hook pushes the button of the microswitch. Then the button of the primary interlock switch bring it under ON condition.

(2) Secondary interlock switch and interlock monitor switch

When the door is closed, the hook pushes the lock lever downward. The lock lever presses the button of the interlock monitor switch to bring it under NO condition. The lock lever presses the button of the secondary interlock switch to bring it under ON condition.

ADJUSTMENT :

Interlock monitor switch

When the door is closed, the interlock monitor switch should be changed (NO condition) before other switches are closed.
When the door is opened, the interlock monitor switch should be changed (NC condition) after other switches are opened.

(3) Adjustment steps

- Loosen the one mounting screw.
- Adjust interlock switch assembly position.
- Make sure that lock lever moves smoothly after adjustment is completed.
- Tighten completely two mounting screws.

NOTE :

Microwave emission test should be performed after adjusting interlock mechanism.
If the microwave emission exceed $4\text{mW}/\text{cm}^2$, readjust interlock mechanism.

TROUBLE SHOOTING GUIDE

Following the procedure below to check if the oven is defective or not.

- 1) Check grounding before trouble checking.
- 2) Be careful of the high voltage circuit.
- 3) Discharge the high voltage capacitor.
- 4) When checking the continuity of the switches, fuse or high voltage transformer, disconnect one load wire from these parts and check continuity with the AC plug removed. To do otherwise may result in a false reading or damage to your meter.

NOTE : When electric parts are checked, be sure the power cord is not inserted the wall outlet.
Check wire harness, wiring and connection of the terminals and power cord before check the parts listed below.

(TROUBLE 1) Oven does not operate at all : any inputs can not be accepted.

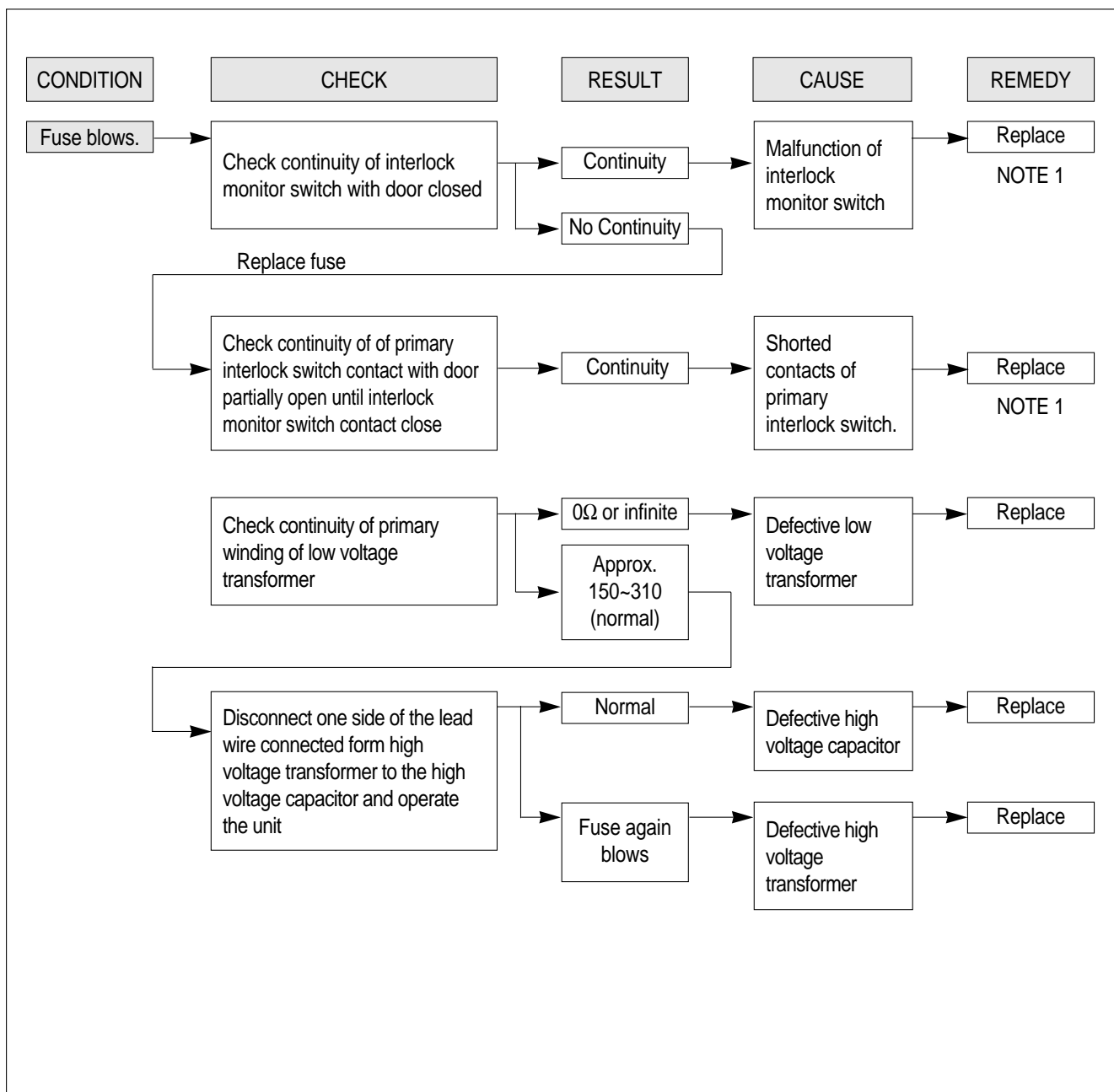

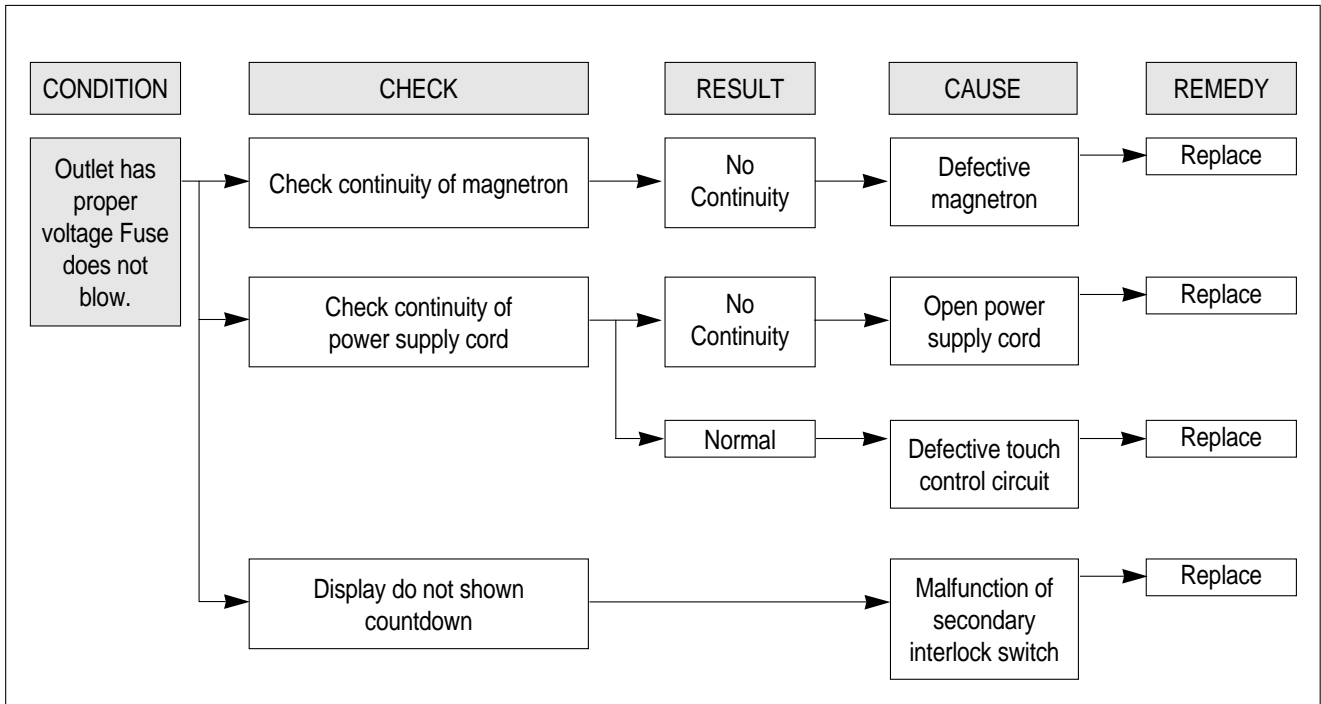

NOTE 1
All these switches must be replaced at the same time, please refer to "Interlock Mechanism And Adjustment".

(TROUBLE 2) Display shows all figures selected, but oven does not start cooking, even though desired program and time are set and start pad is tapped.

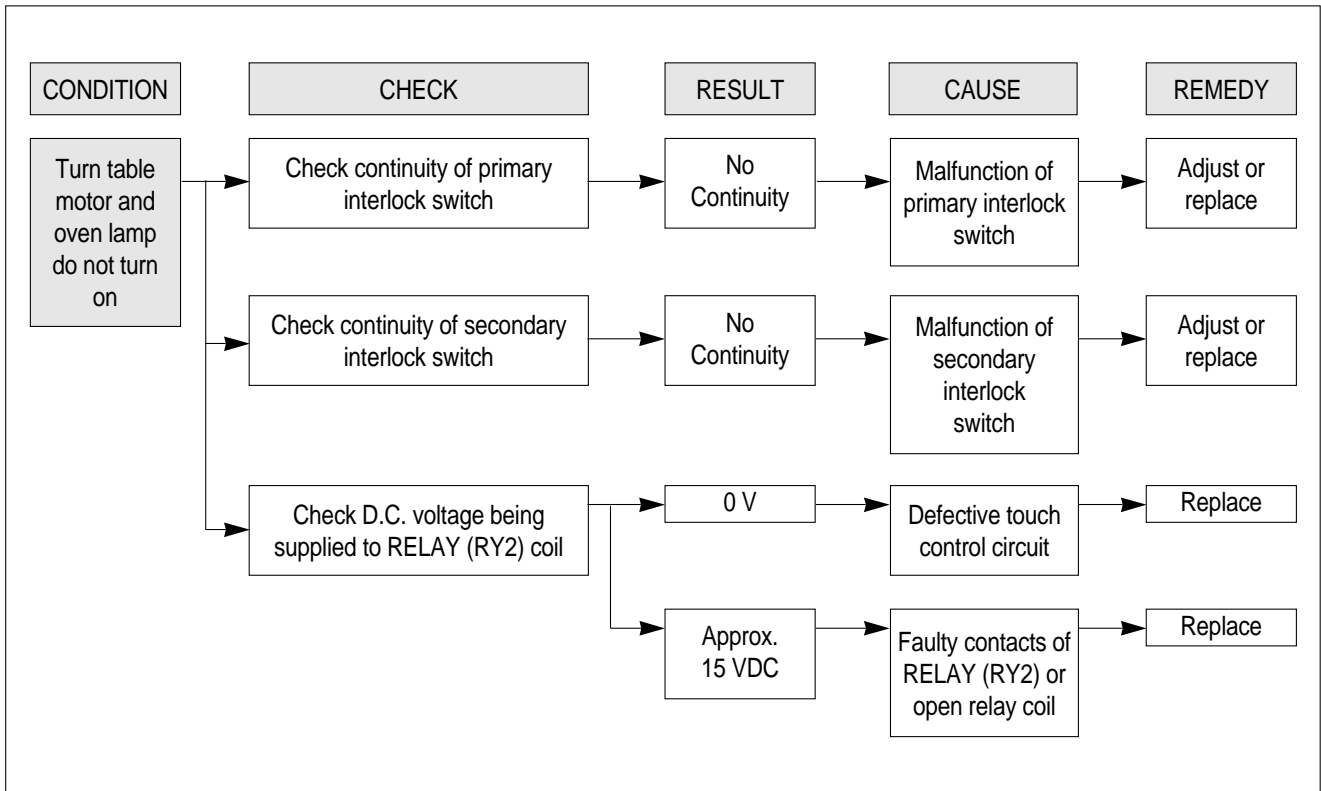

(TROUBLE 3) No microwave oscillation even though fan motor rotates.

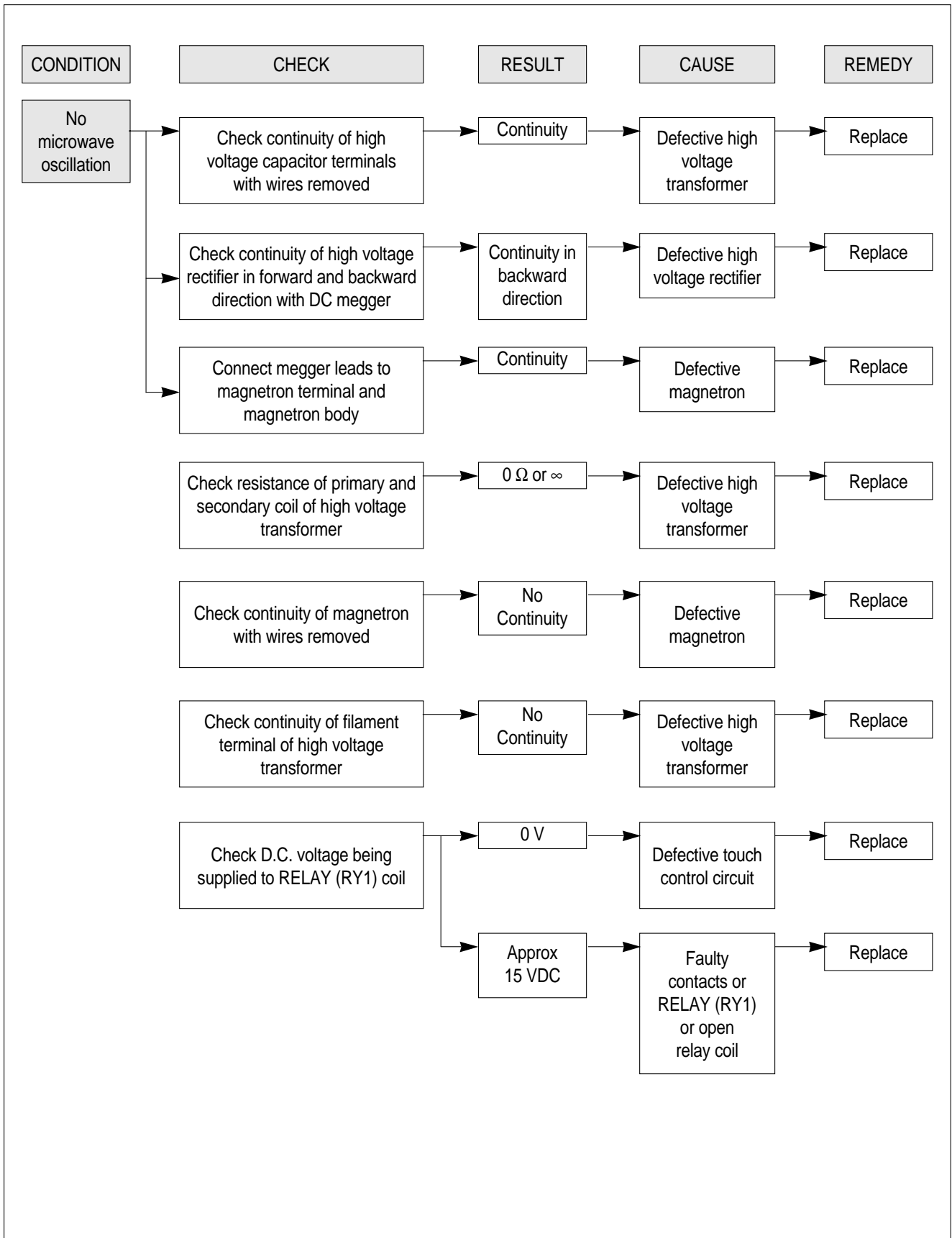

(TROUBLE 4) The following visual conditions indicate a probable defective touch control circuit or membrane switch assembly

1. Incomplete segments,
 - 1) Segments missing.
 - 2) Partical segments missing.
 - 3) Digit flickering other than normal display slight flickering.
 - 4) " :0" does not display when power is on.
2. A distinct change in the display is not on when they should be.
3. One or more digits in the display are not on when they should be.
4. Display indicates a number different from one touched.
5. Specific numbers (for example 2 or 3) will not display when the panel is touched.
6. Display does not count down or up with time cooking or clock operation.
7. Oven is programmable and cooks normally but no display shows.
8. Display obviously jumps in time while counting down.
9. Display counts down noticeable too fast while cooking.
10. Display does not show the time of day when clear pad is touched.
11. Oven lamp and turntable motor do not stop although cooking is finished. Check if the RELAY 2 contacts close if they are close, replace touch control circuit.

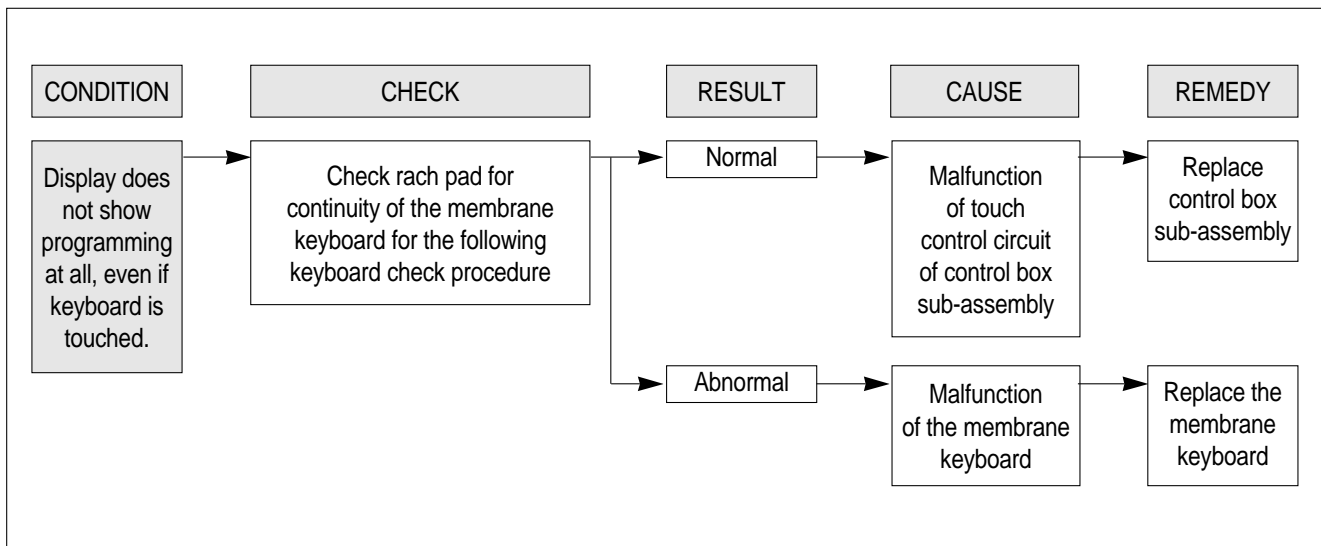
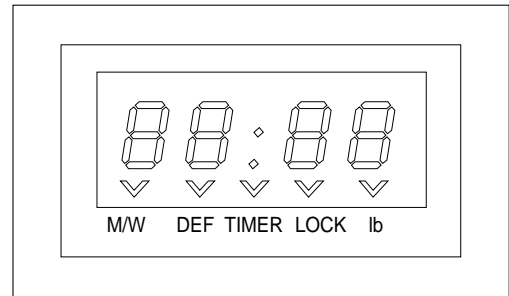

NOTE
 Before following the particular steps listed above in the trouble shooting guide for the membrane keyboard's failure, please check for the continuity of each wire-harness between the membrane keyboard and P.C.B. assembly.

MEASUREMENT AND TEST

1. MEASUREMENT OF THE MICROWAVE POWER OUTPUT

Microwave output power can be checked by indirectly measuring the temperature rise of a certain amount of water exposed to the microwave as directed below.

PROCEDURE

- Microwave power output measurement is made with the microwave oven supplied at rated voltage and operated at its maximum microwave power setting with a load of 100 ± 5 cc of potable water.
- The water is contained in a cylindrical borosilicate glass vessel having a maximum material thickness of 3 mm and an outside diameter of approximately 190 mm.
- The oven and the empty vessel are at ambient temperature prior to the start of the test. The initial temperature of the water is $10 \pm 2^\circ\text{C}$ ($50 \pm 3.6^\circ\text{F}$). It is measured immediately before the water is added to the vessel. After addition of the water to the vessel, the load is immediately placed on the center of the shelf, which is in the lowest normal position.
- Microwave power is switched on.
- Heating time should be exactly A seconds.
(Refer to table as following)
Heating time is measured while the microwave generator is operating at full power. The filament heat-up time for magnetron is not included.
- The initial and final temperature of water is selected so that the maximum difference between the ambient and final water temperature is 5K.
- The microwave power output P in watts is calculated from the following formula:

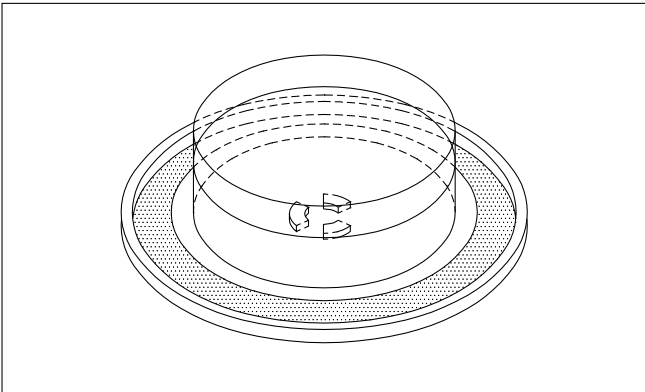

$$P = 4187 \times \Delta T / t$$

- ΔT is difference between initial and final temperature.
 - t is the heating time.
- The power measured be B (Refer to SPECIFICATIONS) $W \pm 10.0 \%$.

CAUTION

- Water load should be measured exactly to 1 liter.
- Input power voltage should be exactly specified voltage (Refer to SPECIFICATIONS).
- Ambient temperature should be $20 \pm 2^\circ\text{C}$ ($68 \pm 3.6^\circ\text{F}$)

* Heating time for power output:

A (second)	70	64	60	56	52	49	47	44	42	40	38
B (W)	600	650	700	750	800	850	900	950	1000	1050	1100

2. MICROWAVE RADIATION TEST

CAUTION

1. Make sure to check the microwave leakage before and after repair of adjustment.
2. Always start measuring of an unknown field to assure safety for operating personnel from microwave energy.
3. Do not place your hands into any suspected microwave radiation field unless the safe density level is known.
4. Care should be taken not to place the eyes in direct line with the source of microwave energy.
5. Slowly approach the unit under test until the radiometer reads an appreciable microwave leakage from the unit under the test.

PROCEDURE

1. Prepare Microwave Energy Survey Meter, 600cc glass beaker, and glass thermometer 100°C (212°F).
2. Pour 275cc \pm 15cc of tap water initially at 20 \pm 5°C (68 \pm 9°F) in the 600 cc glass beaker with an inside diameter of approx. 95 mm(3.5 in.).
3. Place it at the center of the tray and set it in a cavity.
4. Close the door and operate the oven.
5. Measure the leakage by using Microwave Energy Survey Meter with dual ranges, set to 2450MHz.
 - 1) Measured radiation leakage must not exceed the value prescribed below. Leakage for a fully assembled oven with door normally closed must be less than 4mW/cm².
 - 2) When measuring the leakage, always use the 5 cm (2 in.) space cone with probe. Hold the probe perpendicular to the cabinet and door. Place the space cone of the probe on the door, cabinet, door seem, door viewing screen, the exhaust air vents and the suction air vents.
 - 3) Measuring should be in a counter-clockwise direction at a rate of 1 in./sec. If the leakage of the cabinet door seem is unknown, move the probe more slowly.
 - 4) When measuring near a corner of the door, keep the probe perpendicular to the areas making sure the probe end at the base of the cone does not get closer than 2 in. from any metal. If it does not, erroneous reading may result.

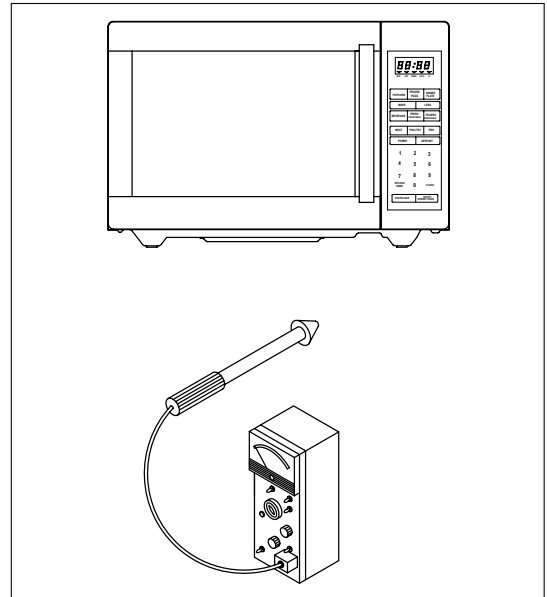

3. COMPONENT TEST PROCEDURE

- High voltage is present at the high voltage terminal of the high voltage transformer during any cooking cycle.
- It is neither necessary nor advisable to attempt measurement of the high voltage.
- Before touching any oven components or wiring, always unplug the oven from its power source and discharge the capacitor.

1. High voltage transformer

- 1) Remove connections from the transformer terminals and check continuity.
- 2) Normal readings should be as follows :
 - Secondary winding ... Approx. $110\ \Omega \pm 10\%$ ($100\ \Omega \pm 10\% \div \text{KOR-1B4H9A04}$)
 - Filament winding ... Approx. $0\ \Omega$
 - Primary winding ... Approx. $1\ \Omega$

2. High voltage capacitor

- 1) Check continuity of capacitor with meter on the highest OHM scale.
- 2) A normal capacitor will show continuity for a short time, and then indicate $10\text{M}\Omega$ once the capacitor charged.
- 3) A shorted capacitor will show continuous continuity.
- 4) An open capacitor will show constant $10\text{M}\Omega$.
- 5) Resistance between each terminal and chassis should be infinite.

3. High voltage diode

- 1) Isolate the diode from the circuit by disconnecting the leads.
- 2) With the ohmmeter set on the highest resistance scale measure the resistance across the diode terminals.
 - Reverse the meter leads and again observe the resistance reading. Meter with 6V, 9V or higher voltage batteries should be used to check the front-back resistance of the diode, otherwise an infinite resistance may be read in both directions. A normal diode's resistance will be infinite in one direction and several hundred k Ω in the other direction.

4. Magnetron

For complete magnetron diagnosis, refer to "Measurement of the Microwave Power Output." Continuity checks can only indicate an open filament or a shorted magnetron. To diagnose for an open filament or a shorted magnetron,

- 1) Isolate magnetron from the circuit by disconnecting the leads.
- 2) A continuity check across magnetron filament terminals should indicate $0.1\ \Omega$ or less.
- 3) A continuity check between each filament terminal and magnetron case should read open.

5. Fuse

If the fuse in the primary and monitor switch circuit is blown when the door is opened, check the primary and monitor switch before replacing the blown fuse. In case the fuse is blown by an improper switch operation, replace the defective switch and fuse at the same time. Replace just the fuse if the switches operate normally.

KOR-1B4H9A04

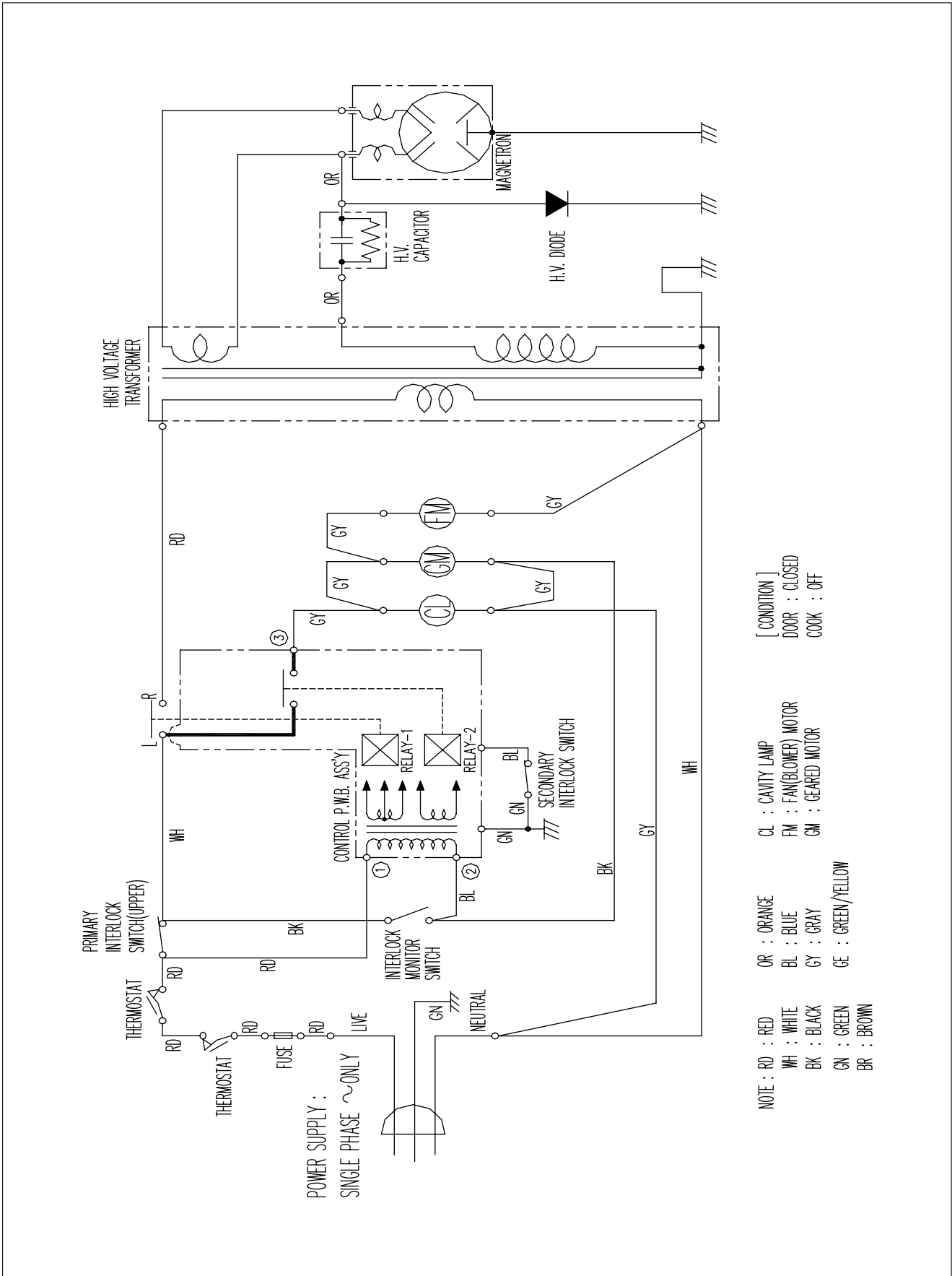

PRINTED CIRCUIT BOARD

1. CIRCUIT CHECK PROCEDURE

1. Low voltage transformer check

The low voltage transformer is located on the P.C.B.

Measuring condition: Input voltage: 120V / Frequency: 60Hz

Terminal Voltage	LOAD	NO LOAD
4-7	AC 12.6 V	AC 14.7 V

NOTE

1. Refer to Circuit Diagram (point 4).
2. Secondary side voltage of the low voltage transformer changes in proportion to fluctuation of power source voltage.
3. The allowable tolerance of the secondary voltage is within $\pm 5\%$ of nominal voltage.

2. Voltage Check

- Key check point

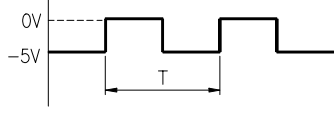
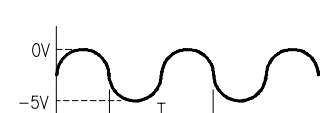
NO	CHECK POINT	REMARK
1	IC1 PIN 2, 21, 30, 34	-5VDC
2	IC1 PIN 35	 <p>T : 16.67ms(60Hz)</p>
3	IC1 PIN 31 OR 32	 <p>T : 250 ns(4MHz)</p>

- Check method

NO	MEASURE POINT	WAVE FORM	REMEDY	REMARK
1	MP1	DC -5V \pm 0.25V	Replace VL1, EC1	NO LOAD
2	MP2	DC -12V \pm 2.0V	Replace EC2, D12,13,14	NO LOAD

NOTE

Each measure point must be measured with GND points.

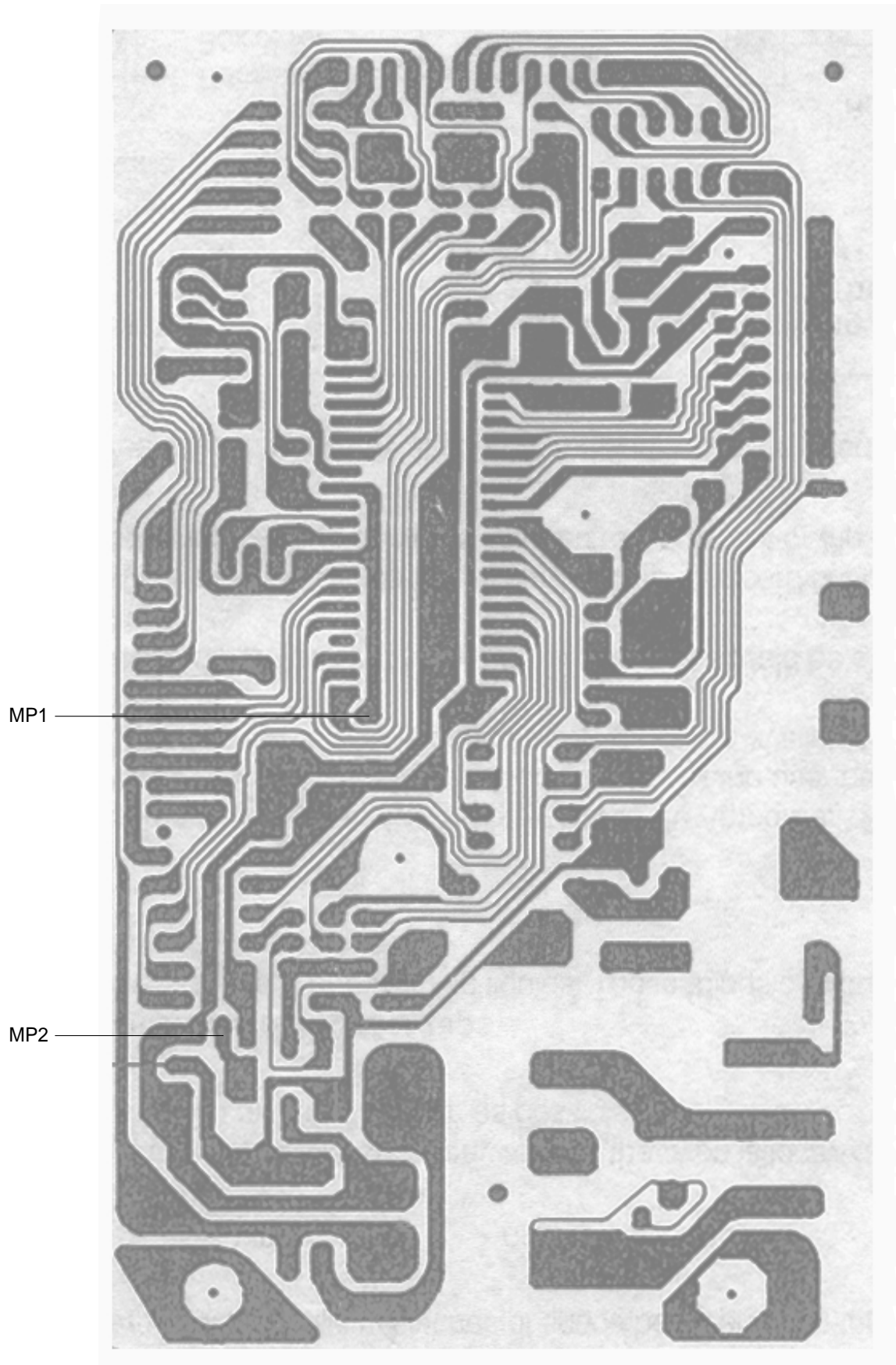

Mesure point

3. When there is no microwave oscillation

- 1) When touching **START** pad, oven lamp does not turn on.
 Fan motor do not rotate, but cook indicator in display comes on.
 * Cause : **RELAY 2** does not operate. → refer to Circuit Diagram (point 3)
 - Check method

STATE \ POINT	A	B
RELAY 2 ON	-5VDC	GND
RELAY 2 OFF	GND	-12VDC

- 2) When touching **START** pad, oven lamp turns on.
 Fan motor and turntable rotate and cook indicator in display comes on.
 * Cause : **RELAY 1** does not operate. → refer to Circuit Diagram (point 2)
 - Check method

STATE \ POINT	A	B
RELAY 1 ON	-5VDC	GND
RELAY 1 OFF	GND	-12VDC

4. When the door is opened during operation the count down timer does not stop.

- refer to Circuit Diagram (point 1)
 - Check method

STATE \ POINT	A	B
1) DOOR OPEN	OPEN	-5VDC
2) DOOR CLOSED	CLOSE	GND

CHECK NO	HETHOD	REMEDY
1	Check the stage(ON, OFF) of the secondary interlock switch by resistance measurement.	Replace door open monitor switch.

5. When the digital clock does not operate properly.

- refer to Circuit Diagram (point 5)

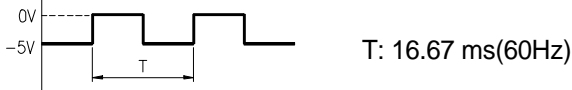
POINT	WAVE FORM
A	

- * If clock does not keep exact time, you must check resistor R15,16, zener diode ZD1.

2. P.C.B. CIRCUIT DIAGRAM

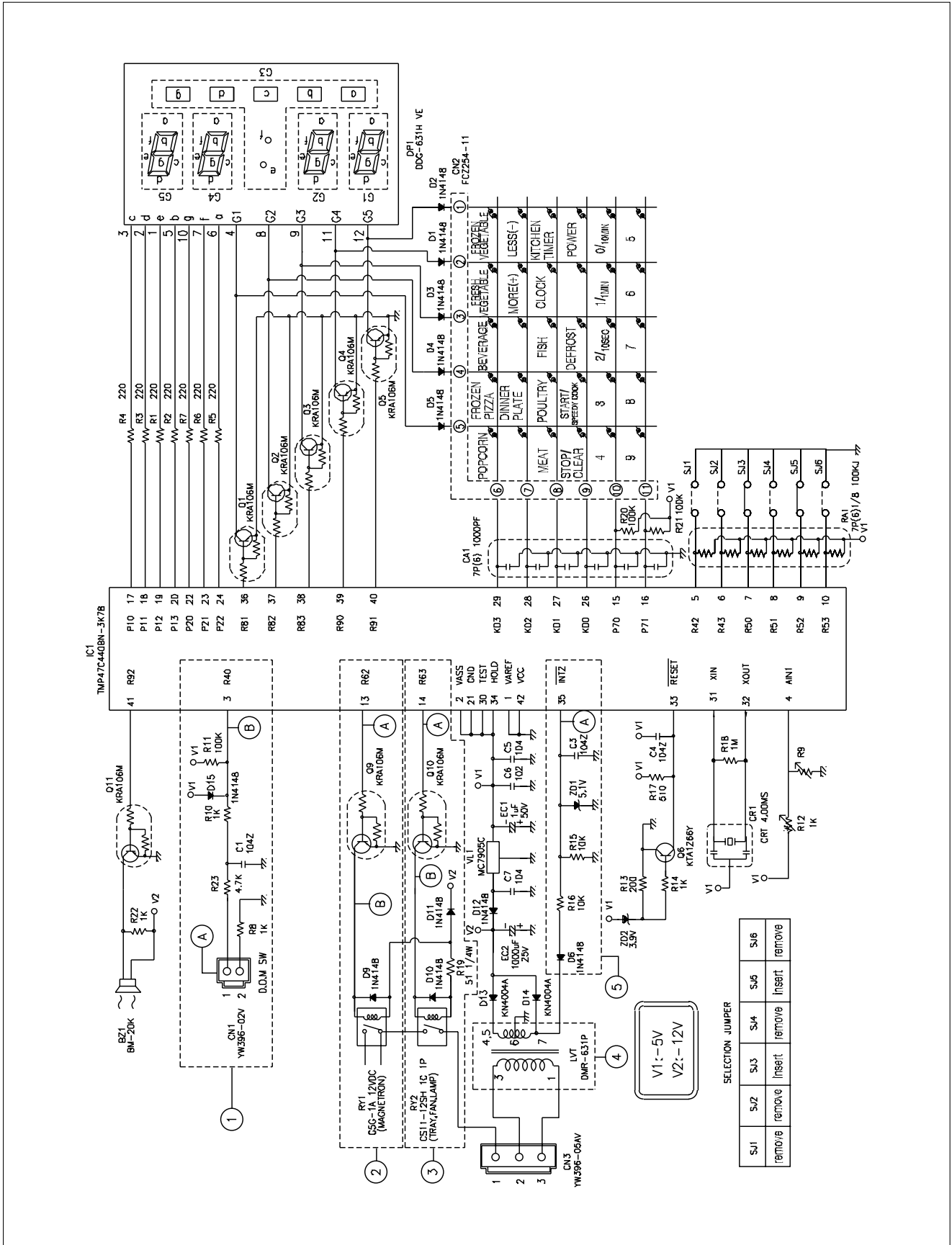

3. P.C.B. LOCATION NO.

NO	NAME	SYMBOL	SPECIFICATION	PART CODE	Q'TY
1	BUZZER	BZ1	BM-20K	3515600100	1
2	C ARRAY	CA1	7P(6) 102 M 50V	CN6XB-102M	1
3	CAPACITOR ELEC	EC1	50V RS 1 μ F	CEXE1H109V	1
4	CPAPCITOR ELEC	EC2	25V RSS 1000 μ F	CXF1E102V	1
5	CONNECTOR WAFER	CN1	YW396-02AV	3519150520	1
6	CONNECTOR WAFER	CN3	YW396-05AV	3519150510	1
7	CONNECTOR WAFER	CN2	FCZ 254-11	441M367160	1
8	DIODE RECTIFY	D1~6, 9~12,15	1N4148	DZN4148---	11
9	DIODE RECTIFY	D13, 14	1N4004A	DZN4004A--	2
10	DIODE ZENER	ZD1	UZ-5.1BSB	DZUZ5R1BSB	1
11	DIODE ZENER	ZD2	UZ-3.9BSB	DZUZ3R9BSB	1
12	LED DISPLAY	DP1	DDG-631H	DDD631H01	1
13	PCB MAIN	M158	81.5X139.9	3514315410	1
14	R ARRAY	RA1	7P(6) 1/8 100K J	RA-87X104J	1
15	RESISTOR	R1~R7	1/6W 220 5%	RD-AZ221J-	7
16	RESISTOR	R8, 10, 12, 14, 22	1/6W 1K 5%	RD-AZ102J-	5
17	RESISTOR	R11, 20, 21	1/6W 100K 5%	RD-AZ104J-	3
18	RESISTOR	R13	1/6W 200 5%	RD-AZ201J-	1
19	RESISTOR	R15~16	1/6W 10K 5%	RD-AZ103J-	3
20	RESISTOR	R17	1/6W 510 5%	RD-AZ511J-	1
21	RESISTOR	R18	1/6W 1M 5%	RD-AZ105J-	1
22	RESISTOR	R19	1/4W 51 5%	RD-4Z510J-	1
23	REGULATOR	VL1	MC7905C	1MC7905C--	1
24	TRANSISTOR	Q1~5, 9~11	KRA-106M	TZRA106M--	8
25	TRANSISTOR	Q6	KTA-1266Y	TZTA1266Y-	1
26	TRANS POWER	LVT1	DMR-631P	5EPU035302	1
27	WIRE COPPER	J1-3,5-8,10-12,17-21	1/0.52 TIN COATING	85801052GY	15
28	WIRE COPPER	SJ3, 5	1/0.52 TIN COATING	85801052GY	2
29	IC MICOM	IC1	TMP47C440BN	13GS1B4H00	1
30	RESONATOR CERA	CR1	KBR-4.0MSTF	5PKBR40MKS	1
31	SW RELAY	RY1	G5G-1A DC 12V	5SC0101121	2
32	SW RELAY	RY2	CS11-12SH 1C 1P	5SC0101128	1
33	CAPACITOR CERA	C6	102 50V Z AXIAL	CCZB1H102K	1
34	CAPACITOR CERA	C1, C3~C5, C7	104 50V Z AXIAL	CCZF1H104Z	5

EXPLODED VIEW AND PARTS LIST

1. DOOR ASSEMBLY

Refer to Disassembly and assembly

2. CONTROL PANEL ASSEMBLY

Refer to Disassembly and assembly

3. TOTAL ASSEMBLY

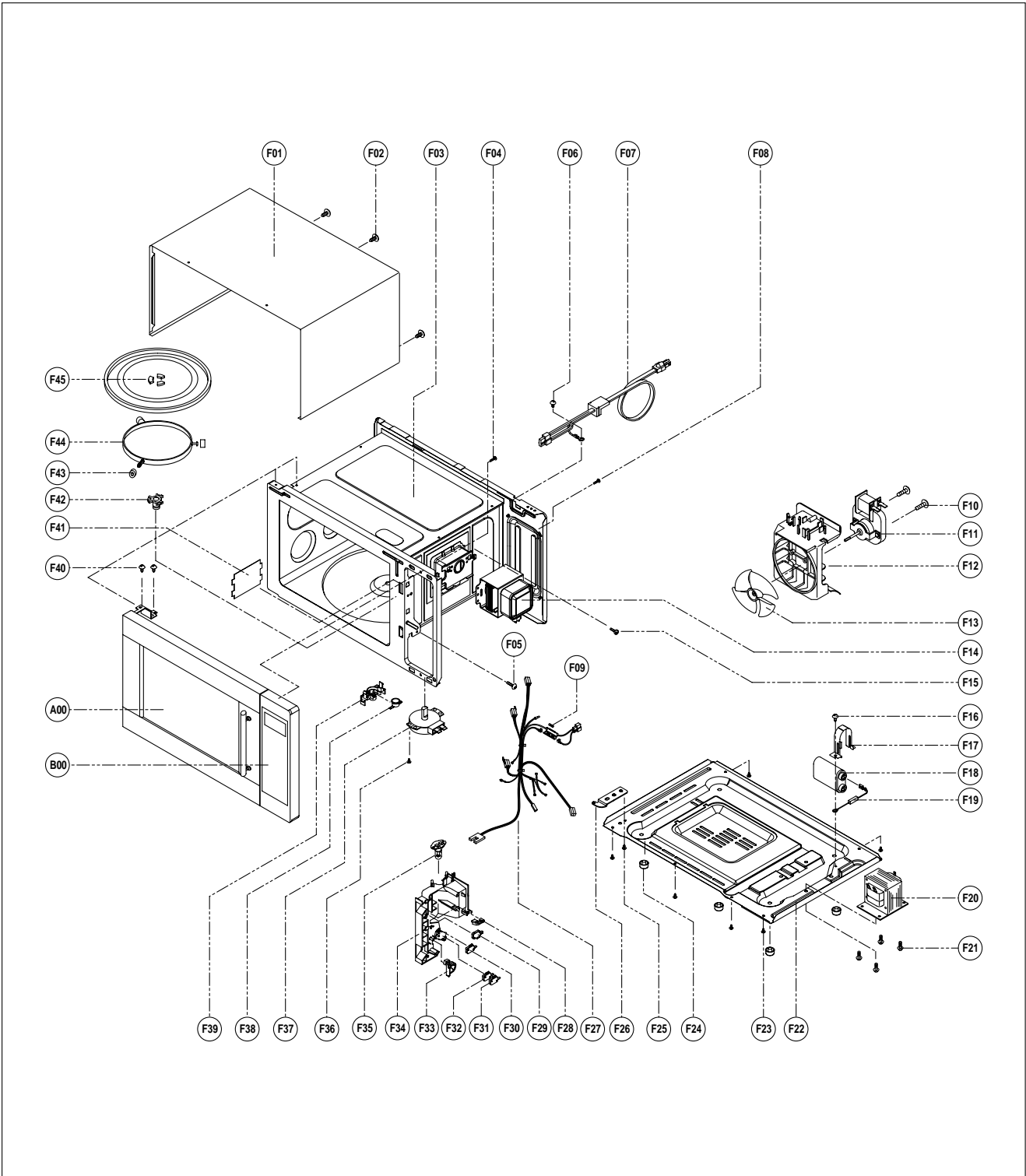

REF NO	PART CODE	PART NAME	DESCRIPTION	Q'TY
A00	3511716000	DOOR AS	KOR-1B4H0A	1
B00	3516727200	CONTROL PANEL AS	KOR-1B4H0A	1
F01	3510806800	CABINET	STS430 T0.5 HL (KOR-1B4H9A04)	1
	3510806810	CABINET	SECC (KOR-1B4H9A04)	
F02	3516004100	SPECIAL SCREW	T1 TRS LR4 POLE 4X10 MFZN	4
F03	3516114400	CAVITY AS	KOR-1B4H0A	1
	3516114410	CAVITY AS	KOR-1B4H9A04	
F04	7122401211	SCREW TAPPING	T2S TRS 4*12 MFZN	1
F05	7122401211	SCREW TAPPING	T2S TRS 4*12 MFZN	1
F06	7122401011	SCREW TAPPING	T2S TRS 4*10 MFZN	1
F07	35113UANT5	CORD POWER AS	3X14 AWG 60X60 120-RTML (KOR-1B4H0A)	1
	35113TENM5	CORD POWER AS	3X16 AWG 70X70 100-RTML (KOR-1B4H9A04)	
F08	7122401211	SCREW TAPPING	T2S TRS 4*12 MFZN	1
F09		FUSE		1
F10	7121403011	SCREW TAPPING	T2S PAN 4X30 MFZN	2
F11	3963822200	MOTOR SHADED POLE	120V 30W OEM-15DWX1-B07	1
F12	3512515300	GUIDE WIND	PP	1
F13	3511800100	FAN	PP GF 20	1
F14	3518003500	MAGNETRON	RM259(JF) (KOR-1B4H0A)	1
	3518002900	MAGNETRON	2M218 (KOR-1B4H9A04)	
F15	3516003800	SPECIAL SCREW	T2 FLANGE 5X8 MFZN	1
F16	7272400811	SCREW TAPTITE	TT3 TRS 4X8 MFZN	1
F17	3513003200	HOLDER HV CAPACITOR	SECC T0.6	1
F18	3518302300	CAPACITOR HV	2100VAC 1.10μF #187 (KOR-1B4H0A)	1
	3518302200	CAPACITOR HV	2100VAC 0.9μF (KOR-1B4H9A04)	
F19	3518400110	DIODE HV	HVR-1X-70B 12KV #187 (KOR-1B4H0A)	1
	3518400400	DIODE HV	HVR-1X-3AB (KOR-1B4H9A04)	
F20	3518118600	TRANS HV	DW-R11A0-1BT (KOR-1B4H0A)	1
	3518118610	TRANS HV	DW-R10A0-1BT (KOR-1B4H9A04)	
F21	3516003700	SPECIAL SCREW	T2 FLANGE 5X8 MFZN	4
F22	3510313520	BASE	SBHG T0.8	1
F23	7112401011	SCREW TAPPING	T1 TRS 4X10 MFZN	6
F24	3512101400	FOOT	DASF-310	4
F25	7272400811	SCREW TAPTITE	TT3 TRS4X8 MFZN	1
F26	3515202800	STOPPER HINGE *U	KOR-121M0A	1
F27	3512717400	HARNESS MAIN	KOR-131G0A	1
	3512719010	HARNESS MAIN	KOR-1B4H9A04	

REF NO	PART CODE	PART NAME	DESCRIPTION	Q'TY
F28	3513702100	LEVER SW MICRO	POM	1
F29	4415A17352	SW MICRO	VP-533A-OF SPNO #187 200G	1
F30	4415A66600	SW MICRO	VP-532A-OF/SPNO #187 200G	1
F31	4415A17352	SW MICRO	VP-533A-OF SPNO #187 200G	1
F32	4415A66910	SW MICRO	VP-531A-OF/SZ,-V16-FA-61	1
F33	3513700800	LEVER LOCK	POM	1
F34	3513816000	LOCK	PP	1
F35	3513601500	LAMP	BL 120V 25W T25 C5A H187	1
F36	7121400611	SCREW TAPPING	T2S PAN 4X6 MFZN	1
F37	3966820200	MOTOR SYNCRO	120V 2W GM-16-12F17	1
F38	3518905600	THERMOSTAT	OFF:80 ON:50 H #187 NR	1
F39	3513003400	HOLDER THERMOSTAT	PP(NATURAL)	1
F40	7272400811	SCREW TAPTITE	TT3 TRS 4X8 MFZN	2
F41	3511408300	COVER WAVE GUIDE	MICA T0.35	1
F42	3517402000	COUPLER	QUESTRA	1
F43	3514700710	ROLLER	TEFLON	3
F44	3512517200	GUIDE ROLLER	PP	
F45	3517207600	TRAY	DIA:340 1300G	1
F46	3518902900	THERMOSTAT	OFF:144°C #187V (Only KOR-1B4H9A04)	1
F47	7121300611	SCREW TAPPING	T2S PAN 3X6 (Only KOR-1B4H9A04)	2

DAEWOO

DAEWOO ELECTRONICS CO., LTD.
686, AHYEON-DONG MAPO-GU SEOUL, KOREA
C.P.O. BOX 8003 SEOUL, KOREA
TELEX: DWELEC K28177-8
CABLE: "DAEWOOELEC"

PRINTED DATE: Mar, 2002

S/M NO. : R1B4H0A002