

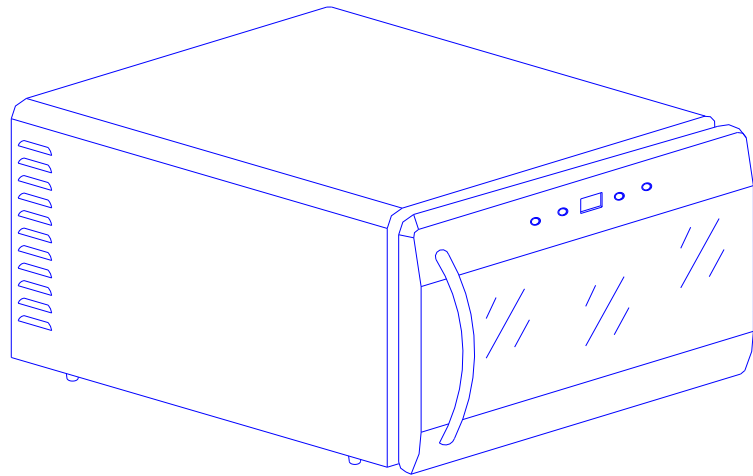

## **8 BOTTLE COUNTERTOP WINE COOLER INSTRUCTION MANUAL**

**Model No.: MCWC8DCT3**



**To ensure proper use of this appliance and your safety, please read the following instructions completely before operating this appliance.**

# TABLE OF CONTENTS

---

NAMES OF THE PARTS.....	2
SPECIFICATIONS.....	2
IMPORTANT SAFETY INSTRUCTIONS.....	3
INSTALLATION INSTRUCTIONS	
BEFORE USING YOUR WINE COOLER.....	3
INSTALLING YOUR WINE COOLER .....	3
ELECTRICAL CONNECTION.....	4
OPERATING YOUR WINE COOLER	
TEMPERATURE CONTROL.....	5
CARE AND MAINTENANCE	
CLEANING YOUR WINE COOLER.....	6
VACATION TIME.....	6
MOVING YOUR WINE COOLER.....	6
ENERGY SAVING TIPS.....	6
TROUBLESHOOTING GUIDE.....	7
WINE COOLER WARRANTY.....	8

# NAMES OF THE PARTS

---

## MODEL NO. MCWC8DCT3

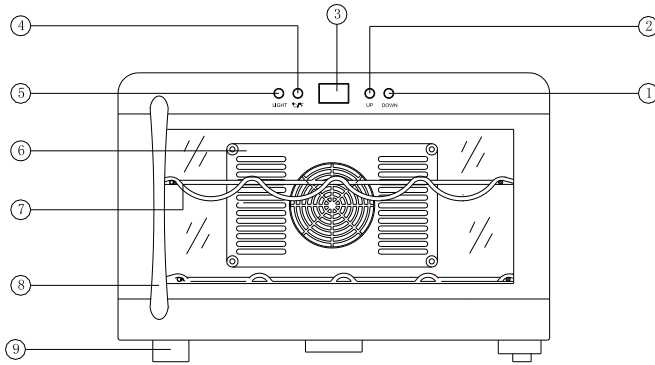

1. Temp. -
2. Temp. +
3. LCD DISPLAY
4. "°C/°F" SWITCH
5. INTERIOR LIGHT BUTTON
6. FAN MASK
7. SHELF
8. HANDLE
9. FOOT

# SPECIFICATIONS – Model # MCWC8DCT3

---

Product Description	Magic Chef 8 Bottle Countertop Wine cooler		
Model No.	MCWC8DCT3		
Unit Dimensions ( inches )	Width	Height	Depth
	16.5"	11.2"	20.7"
Net Weight ( lbs)	22lbs		

# IMPORTANT SAFETY INSTRUCTIONS

<b>⚡ WARNING ⚡</b>	To reduce the risk of fire, electrical shock, or injury when using your wine cooler, follow these basic precautions:
<ul style="list-style-type: none"><li>• Read all instructions before using the wine cooler.</li><li>• Never clean wine cooler parts with flammable fluids. The fumes can create a fire hazard or explosion.</li><li>• Do not store or use gasoline or any other flammable vapors and liquids in the vicinity of this or any other wine cooler. The fumes can create a fire hazard or an explosion.</li></ul> <p style="text-align: center;">-Save these instructions-</p>	

## INSTALLATION INSTRUCTIONS

### Before Using Your Wine cooler

- Remove the exterior and interior packing.
- Clean the interior surface with lukewarm water using a soft cloth. (Cleaning instruction on page 6)

### Installing Your Wine cooler

- This appliance is designed to be free standing only, and should not be recessed or built-in.
- Allow 5 inches of space between the back and sides of the wine cooler, which allows the proper air ventilation. Adjust the feet to keep the wine cooler level.
- Locate the wine cooler away from direct sunlight and sources of heat (stove, heater, radiator, etc.). Direct sunlight may affect the acrylic coating and heat sources may increase electrical consumption. Ambient temperature below 46°F (8°C) or above 86°F (30°C) will hinder the performance of this appliance. It is recommended to be used with ambient temperature between 60°F (15°C) to 83°F (28°C). **This unit is not designed for use in a garage or any other outside installation.**
- Avoid locating the wine cooler in moist areas.
- Plug the wine cooler into dedicated, properly installed-grounded wall outlet. Do not under any circumstances cut or remove the third (ground) prong from the power cord. Any questions concerning power and/or grounding should be directed toward a certified electrician or an authorized service center. **This unit is not designed to be installed in an RV or used with an inverter.**
- After plugging the appliance into a wall outlet, turn the unit on and allow the unit to cool down for 3 ~ 4 hours under before placing wine bottles in the wine cooler.

## Electrical Connection

### **⚡WARNING⚡**

Improper use of the grounded plug can result in the risk of electrical shock. If the power cord is damaged, have it replaced by an authorized service center.

This wine cooler should be properly grounded for your safety. The power cord of this wine cooler is equipped with a three-prong plug which mates with standard three prong wall outlets to minimize the possibility of electrical shock.

Do not, under any circumstances, cut or remove the third ground prong from the power cord supplied.

This wine cooler requires a standard 100-120 Volt A.C. /60Hz electrical outlet with three-prong ground.

This wine cooler is not designed to be used with an inverter.

The cord should be secured behind the wine cooler and not left exposed or dangling to prevent accidental injury.

Never unplug the wine cooler by pulling the power cord. Always grip the plug firmly and pull straight out from the receptacle.

Do not use an extension cord with this appliance. If the power cord is too short, have a qualified electrician or service technician install an outlet near the appliance. Use of an extension cord can negatively affect the performance of the unit.

If any problems with the appliance persist, please contact our Customer Service Dept. to consult with a representative at **888 775-0202** or visit our website to request warranty service at **[www.mcappliance.com](http://www.mcappliance.com)**.

# OPERATING YOUR WINE COOLER

## Temperature Control

- The LCD display will show the actual temperature of the inside cabinet.
- The interior temperature can be set to between 8°C (46°F) and 18°C (64°F) on the control panel.
- Press the up button to increase the temperature of inside the wine cooler.  
Press the down button to decrease the temperature of inside the wine cooler.
- Keep pressing the up/down buttons until the desired temperature is displayed. The LCD display will flash and show the desired temperature for several seconds. After a few seconds, the display will stop flashing and the readout will show the actual temperature of the inside cabinet.
- While the wine cooler is working to achieve the desired set temperature, the LCD display will show the actual temperature of inside cabinet.

**NOTE:** There may be a small temperature difference ( $\pm 2^{\circ}\text{C}$  between the LCD display and the actual temperature of inside cabinet)

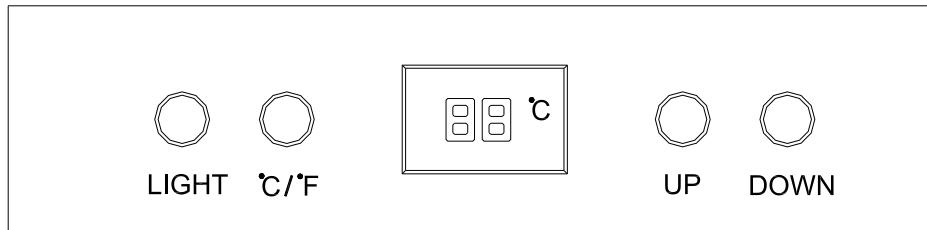

- **NOTE:**
  - If the unit is unplugged, loses power; you must wait 3 to 5 minutes before restarting the unit. If you attempt to restart before this time delay, the wine cooler may not start.
  - If there are no items inside the wine cooler, it may take approximately 3 ~ 4 hours to reach the desired temperature setting.
  - The wine cooler is designed to fit eight standard unopened wine bottles. Bottles of different sizes or opened bottles may need to be positioned at different angles and therefore affect the storage capacity of the wine cooler.

# CARE AND MAINTENANCE

## Cleaning Your Wine cooler

- Upon installation of your new appliance, it is recommended that it be cleaned thoroughly.
- Turn off the wine cooler first and then unplug the unit from the wall outlet.
- Remove all contents.
- Wash the inside with a damp warm cloth soaked in lukewarm water and baking soda solution. The solution should be about 2 tablespoons of baking soda to a quart of water.
- Be sure to keep the door gasket (seal) clean to keep the unit running efficiently.
- The outside of the wine cooler should be cleaned with mild detergent and warm water.
- Dry the interior and exterior with a soft cloth.
- Dust or anything else blocking the vent may hinder the cooling efficiency of the wine cooler. Vacuum the vent if necessary.

## Vacation Time

- Turn off the wine cooler first and then unplug the unit from the wall outlet.
- Remove all the contents.
- Clean the wine cooler.
- Leave the lid open slightly to avoid possible formation of condensation, mold, or odors.
- **Short vacations:** Leave the wine cooler operating during vacations of less than three weeks.
- **Long vacations:** If the appliance will not be used for several months, remove all content and unplug the power cord. Clean and dry the interior thoroughly. To prevent odor and mold growth, leave the door open slightly: blocking it open if necessary.

## Moving Your Wine cooler

- Turn off the wine cooler first and then unplug the unit from the wall outlet.
- Remove all the contents.
- Securely tape down all loose items inside your wine cooler.
- Tape the doors shut.

## Energy Saving Tips

- The wine cooler should be located in the coolest area of the room, away from heat producing appliances or heating ducts, and out of the direct sunlight.
- Ensure that door is closed when the wine cooler is turned on.

# TROUBLESHOOTING GUIDE

---

You can solve many common wine cooler problems easily, saving you the cost of a possible service call. Try the suggestions below to see if you can solve the problem before calling for service.

PROBLEM	POSSIBLE CAUSE
Wine cooler does not operate.	Not plugged in. The circuit breaker tripped or a blown fuse.
Temperature inside the wine cooler is too warm.	Temperature control is set too warm. Turn the control to a cooler setting and allow several hours for the temperature to stabilize. Door is kept open too long or is opened too frequently. Warm air enters the wine cooler every time the door is opened. Open the door less often. The door is not closed completely. The door gasket does not seal properly. The wine cooler has recently been disconnected for a period of time. 4 hours are required for the wine cooler to cool down completely.
Temperature inside the wine cooler is too cold.	Temperature control is set too cold. Turn the control to a warmer setting and allow several hours for the temperature to stabilize.
Vibrations.	Check to assure that the wine cooler is on a level surface. The wine cooler is touching the wall. Re-level the wine cooler and move it from the wall. If continued vibration occurs, turn off the wine cooler and unplug the power plug. Contact Customer Service Dept. for further assistance.
Moisture forms on inside wine cooler walls.	Door is slightly open. Door is kept open too long, or is opened too frequently. Open the door less often. The door is not sealed properly.
Moisture forms on outside of wine cooler.	Door is slightly open, causing cold air from inside the wine cooler to meet warm moist air from outside.
The door will not close properly.	The wine cooler is not on a level surface. The gasket is dirty.





## Wine cooler Warranty

**MC Appliance Corporation** warrants each new Wine cooler to be free from defects in material and workmanship and agrees to remedy any such defect or to furnish a new part(s) (at the company's option) for any part(s) of the unit that has failed during the warranty period. Parts and labor expenses are covered on this unit for a period of one year after the date of purchase. **A copy of the dated sales receipt / invoice is required to receive warranty service or a refund.**

**This warranty covers appliances in use within the continental United States, Puerto Rico and Hawaii. The warranty does not cover the following:**

- Damages due to shipping damage or improper installation.
- Damages due to misuse or abuse.
- Content losses due to failure of the unit.
- Inside components such as door panels, door shelves, racks, light bulbs, etc.
- Punctures to the evaporator system due to improper defrosting of the unit.
- Repairs performed by unauthorized service agents.
- Service calls that do not involve defects in material and workmanship such as instruction on proper use of the product, door reversal or improper installation.
- Replacement or resetting of house fuses or circuit breakers.
- Failure of this product if used for other than for its intended purpose.
- Disposal costs for any failed unit not returned to our factory.
- Any delivery costs incurred as the result of a unit that fails to perform as specified.

**This warranty is in lieu of all warranties expressed or implied and no representative or person is authorized to assume for us any other liability in connection with the sale of this product. Under no circumstances is the consumer permitted to return this unit to the factory without prior written consent from **MC Appliance Corporation.****

Model	Parts	Labor	Type of Service
<b>MCWC8DCT3</b>	One-Year	One-Year	Carry-In

For Service or Assistance please call **888 775-0202**. Or visit us on the web at **[www.mcappliance.com](http://www.mcappliance.com)** to request warranty service.