

TO THE INSTALLER: PLEASE LEAVE THIS INSTRUCTION BOOK WITH THE UNIT.

TO THE CONSUMER: PLEASE READ AND KEEP THIS BOOK FOR FUTURE REFERENCE.

Use & Care

G U I D E

One Speed Automatic Washer

A Note to You.....	2
Washer Safety.....	3
Parts and Features.....	4
Using Your Washer.....	5
Starting your washer	5
Loading.....	6
Selecting a cycle, time and temperature	7
Adding liquid chlorine bleach	8
Adding liquid fabric softener.....	8
Rinse/drain and spin	8
Self-cleaning lint filter	9
Understanding normal washer sounds	9
Understanding what happens in each cycle.....	10
Caring For Your Washer	11
Troubleshooting	12
Assistance or Service.....	15
Warranty	20

1-800-447-6737
Call us with questions or comments.



Home Appliances

www.roper.com

In Canada

www.RoperAppliances.com/canada

A NOTE TO YOU

Thank you for buying a ROPER® appliance.

Your ROPER appliance gives you all the functionality of name brand appliances at a value price. To ensure that you enjoy years of trouble-free operation, we developed this Use and Care Guide. It is full of valuable information about how to operate and maintain your appliance properly and safely. Please read it carefully.

Also, please complete and mail the **Product Registration Card** provided with your appliance. The card helps us notify you about any new information on your appliance.

Please record your model's information.

Whenever you call to request service for your appliance, you need to know your complete model number and serial number. You can find this information on the model and serial number label/plate (see the diagram in the "Parts and Features" section).

Please also record the purchase date of your appliance and your dealer's name, address, and telephone number.

Model Number _____

Serial Number _____

Purchase Date _____

Dealer Name _____

Dealer Address _____

Dealer Phone _____

Keep this book and the sales slip together in a safe place for future reference.

Our Consumer Assistance Center number is toll-free.

1-800-447-6737

WASHER SAFETY

Your safety and the safety of others is very important.

We have provided many important safety messages in this manual and on your appliance. Always read and obey all safety messages.



This is the safety alert symbol.

This symbol alerts you to hazards that can kill or hurt you and others.

All safety messages will be preceded by the safety alert symbol and the word "DANGER" or "WARNING." These words mean:

⚠ DANGER

You will be killed or seriously injured if you don't follow instructions.

⚠ WARNING

You can be killed or seriously injured if you don't follow instructions.

All safety messages will identify the hazard, tell you how to reduce the chance of injury, and tell you what can happen if the instructions are not followed.

IMPORTANT SAFETY INSTRUCTIONS

WARNING: To reduce the risk of fire, electric shock, or injury to persons when using the washer, follow basic precautions, including the following:

- Read all instructions before using the washer.
- Do not wash articles that have been previously cleaned in, washed in, soaked in, or spotted with gasoline, dry-cleaning solvents, other flammable, or explosive substances as they give off vapors that could ignite or explode.
- Do not add gasoline, dry-cleaning solvents, or other flammable, or explosive substances to the wash water. These substances give off vapors that could ignite or explode.
- Under certain conditions, hydrogen gas may be produced in a hot water system that has not been used for 2 weeks or more. **HYDROGEN GAS IS EXPLOSIVE.** If the hot water system has not been used for such a period, before using the washing machine, turn on all hot water faucets and let the water flow from each for several minutes. This will release any accumulated hydrogen gas. As the gas is flammable, do not smoke or use an open flame during this time.
- Do not allow children to play on or in the washer. Close supervision of children is necessary when the washer is used near children.
- Before the washer is removed from service or discarded, remove the lid.
- Do not reach into the washer if the tub or agitator is moving.
- Do not install or store the washer where it will be exposed to the weather.
- Do not tamper with controls.
- Do not repair or replace any part of the washer or attempt any servicing unless specifically recommended in this Use and Care Guide or in published user-repair instructions that you understand and have the skills to carry out.
- See Installation Instructions for grounding requirements.

SAVE THESE INSTRUCTIONS

PARTS AND FEATURES

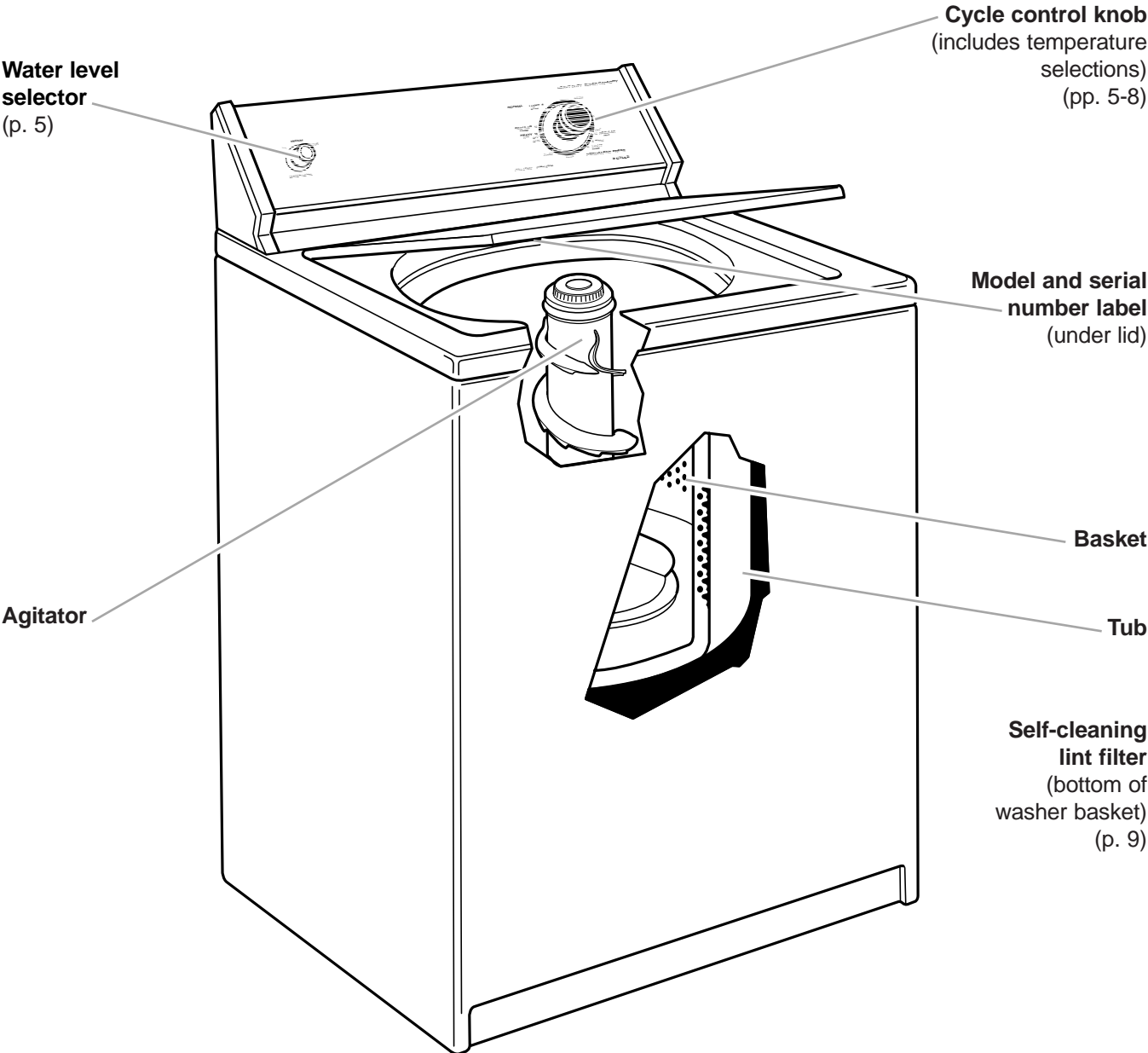

USING YOUR WASHER

STARTING YOUR WASHER

⚠️ WARNING



Fire Hazard

Never place items in the washer that are dampened with gasoline or other flammable fluids.

No washer can completely remove oil.

Do not dry anything that has ever had any type of oil on it (including cooking oils).

Doing so can result in death, explosion, or fire.

⚠️ WARNING



Electrical Shock Hazard

Plug into a grounded 3 prong outlet.

Do not remove ground prong.

Do not use an adapter.

Do not use an extension cord.

Failure to follow these instructions can result in death, fire, or electrical shock.

1. Measure detergent and pour it into the washer. If desired, add powdered or liquid color-safe bleach.
2. Drop a sorted load of clothes loosely into your washer.
 - Load evenly to maintain washer balance.
 - Mix large and small items. See the "Loading" section.
3. Close the washer lid.
4. Turn the Water Level selector to the correct setting for your wash load and the type of fabric being washed.
 - Choose a water level that allows the load to move freely. See "Loading" later in this section.
 - Change the setting after the water has started filling by turning the selector to a different setting.

5. Push in the Cycle Control knob and turn it clockwise to the desired wash cycle. See "Selecting a cycle, time and temperature" later in this section.

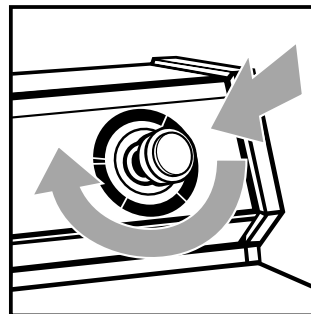

6. Pull out the Cycle Control knob to start the washer.

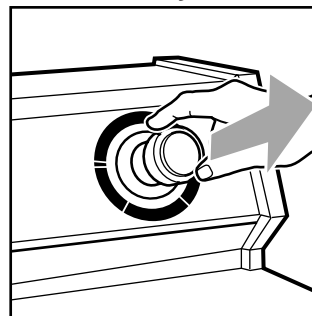

continued on next page

STARTING YOUR WASHER (CONT.)

7. (OPTIONAL STEP) If desired, add measured liquid chlorine bleach after the washer starts agitating. See “Adding Liquid Chlorine Bleach” later in this section.

8. (OPTIONAL STEP) If desired, add measured liquid fabric softener to the rinse water. See “Adding Liquid Fabric Softener” later in this section.

NOTE: To **stop** the washer at any time, push in the Cycle Control knob. To **restart** the washer, close the lid (if open) and pull out the Cycle Control knob.

LOADING

Loading suggestions

For these suggested full-sized loads, set the Load Size selector to the highest water level setting.

EXTRA LARGE CAPACITY WASHERS

Heavy Work Clothes	Permanent Press	Mixed Load	Towels
2 pair pants 3 shirts 3 pair jeans 1 coverall	1 double sheet 1 tablecloth 1 dress 1 blouse 2 slacks	2 double or 1 king size sheet(s) 4 pillowcases 6 T-shirts 6 pair shorts 2 shirts 2 blouses 6 handkerchiefs	8 bath towels 8 hand towels 10 wash cloths 1 bath mat
Knits 2 slacks 2 blouses 4 shirts 4 tops 2 dresses	3 shirts 2 pillowcases		Delicates 2 camisoles 4 slips 4 panties 2 bras 2 nighties

SUPER CAPACITY WASHERS

Heavy Work Clothes	Delicates	Towels	Mixed Load
3 pair pants 3 shirts 4 pair jeans 1 coverall 1 overall	3 camisoles 1 quilted robe 4 slips 4 panties 2 bras 2 nighties 1 baby's dress	10 bath towels 10 hand towels 14 wash cloths 1 bath mat	3 double sheets 4 pillowcases 8 T-shirts 6 pair shorts 2 shirts 2 blouses 8 handkerchiefs

SELECTING A CYCLE, TIME AND TEMPERATURE

This section describes the available wash cycles and will help you make the best cycle selections for your wash loads. Each cycle is designed for different types of fabric and soil levels.

- The washer pauses briefly throughout each cycle. These pauses are normal. Refer to “Understanding normal washer sounds” to learn more about the sounds you may hear during a wash cycle.
- Refer to “Understanding what happens in each cycle” later in this section to learn what happens during a wash cycle.

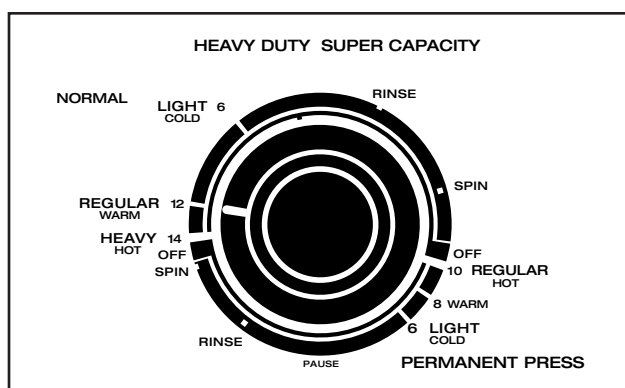

NOTE: This manual covers several different models. The washer you purchased may not have all of the cycles described.

Normal cycle

The Normal cycle includes Light, Regular, and Heavy settings.

- **Heavy** features hot water and longer spins to shorten drying time. Select this 14 minute cycle to clean large loads of sturdily constructed fabrics that are heavily soiled.
- **Regular** features warm water and longer spins to shorten drying time. Use this 12 minute cycle to clean cotton and linen fabrics that are moderately to heavily soiled.
- **Light** features a brief wash with cold water followed by the spin. Use this 6 minute cycle for cleaning delicate items and washable knits that are lightly to moderately soiled.

Permanent Press cycle

The Permanent Press cycle includes Regular and Light settings.

- **Regular** features warm water (8 minutes) or hot water (10 minutes), a cool-down rinse, and shorter spins to reduce wrinkling. Select this cycle for cleaning permanent press and some synthetic fabrics that are moderately or heavily soiled.
- **Light** features cold water, a cool-down rinse, and shorter spins to reduce wrinkling. Select this cycle for cleaning permanent press and some synthetic fabrics that are lightly soiled.

Cycle options

You may select a different wash time by first selecting the water temperature (Hot, Warm, or Cold) and then turning to the new wash time. For example, for 14 minutes of wash time with cold water:

1. Push in the Cycle Control knob and turn it clockwise to Cold.
2. Pull out the Cycle Control knob and allow your washer to fill.
3. When your washer has filled, push in and turn the Cycle Control knob to Heavy.
4. Pull out the Cycle Control knob.

ADDING LIQUID CHLORINE BLEACH

Always measure liquid chlorine bleach. Do not guess. Never use more than 1 cup (250 mL) for a full load. Follow manufacturer's directions for safe use. Use a cup with a pouring spout to avoid spilling.

1. Let the washer fill and begin agitating the load.
2. Add bleach to the wash cycle so it can be removed in the rinse cycle. Pour bleach around the agitator, not directly on the load.

- Follow directions on care labels. Do not use chlorine bleach on wool, silk, spandex, acetates, or some flame-retardant fabrics.
- When soaking with chlorine bleach, add detergent to soak water.

NOTE: Undiluted bleach will damage any fabric it touches. The damage appears as rips, holes, tears, or color loss and may not show up until several washings later.

ADDING LIQUID FABRIC SOFTENER

- Always dilute fabric softener with ½ to 1 cup (125 to 250 mL) warm water. Undiluted fabric softener can stain fabrics.
- Add diluted fabric softener only in the final rinse.
- Fabric softener should not be mixed with other laundry products because greasy stains may form. If stains form, remove them by wetting the stain and rubbing with liquid detergent or a bar of soap. Rewash the stained item.

- Too much fabric softener can make some items (diapers and towels) nonabsorbent. If this happens, use less fabric softener or do not use it every time.

RINSE/DRAIN AND SPIN

Rinse and Spin feature

When using extra detergent for heavily soiled clothes, or washing special-care items, you may find an extra rinse and spin is needed.

- For an additional rinse and spin, push in the Cycle Control knob and turn it clockwise to any of the Rinse settings. The washer fills to the selected load size, agitates, drains, and spins.

Drain and Spin feature

A drain and spin may help shorten drying times for some heavy fabrics or special-care items by removing excess water.

- For a drain and spin, push in the Cycle Control knob and turn it clockwise to any of the Spin settings. Then pull out the Cycle Control knob. The washer drains, then spins.

SELF-CLEANING LINT FILTER

Your washer has a self-cleaning lint filter at the bottom of the basket. Wash and rinse water flow over the filter during agitation, separating the lint from the water. The lint spins out of the system during the spin part of the cycle.

If your washer drains into a tub, remove any lint collected in the tub or strainer.

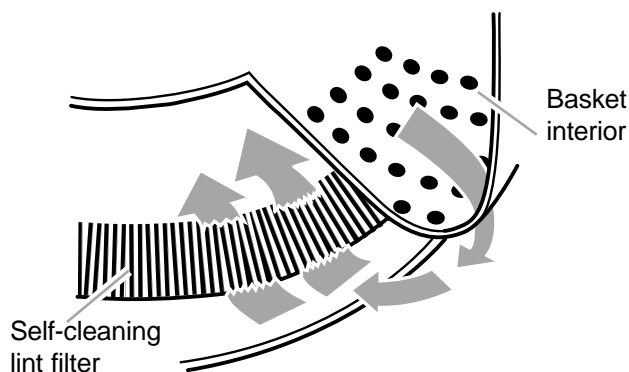

UNDERSTANDING NORMAL WASHER SOUNDS

Your new washer may make sounds your old one didn't. Because the sounds may be unfamiliar, you may be concerned about them. Don't be; most of them are normal.

The following describes some of the sounds you may hear and what causes them.

During drain

If water is drained quickly from your washer (depending on your installation), you may hear air being pulled through the pump during the end of draining.

After drain and before spin

When the cycle changes from draining to spinning, you may hear gears engaging.





UNDERSTANDING WHAT HAPPENS IN EACH CYCLE

When the Cycle Control knob is set to a number and pulled out, the washer fills (to the selected water level) before agitation and timing start. The washer begins agitating immediately after filling; agitation occurs with the washer lid up or down.







After agitation starts, the Cycle Control knob turns clockwise until it points to an Off area and the cycle ends.

NOTE: The washer pauses briefly throughout each cycle. These pauses are normal for washer operation.

Sequence of cycles

WASH	
	Fill ↓
	Wash selected time ↓
	Drain* No agitation ↓
	Spin ↓

*The Permanent Press cycle partially drains, fills, agitates briefly, and drains.

RINSE	
	Fill ↓
	Rinse ↓
	Drain-No agitation ↓
	Spin-Spray rinse ↓
	Spin ↓
	Off

CARING FOR YOUR WASHER

CLEANING YOUR WASHER

Cleaning the exterior

Use a soft, damp cloth or sponge to wipe up any spills such as detergent or bleach. Occasionally wipe the outside of your washer to keep it looking new.



Cleaning the interior

Clean your washer interior by mixing 1 cup (250 mL) of chlorine bleach and 2 cups (500 mL) of detergent. Pour this into your washer and run it through a complete cycle using hot water. Repeat this process if necessary.

NOTE: Remove any hard water deposits using only cleaners labeled as washer safe.

WINTER STORAGE, MOVING, VACATION CARE

Install and store your washer where it will not freeze. Because some water may stay in the hoses, freezing can damage your washer. If storing or moving your washer during freezing weather, winterize it.

To winterize washer:

1. Shut off both water faucets.
2. Disconnect and drain water inlet hoses.
3. Put 1 quart (1 L) of R.V.-type antifreeze in the basket.
4. Run washer on a drain and spin setting (see the "Drain and spin feature" section) for about 30 seconds to mix the antifreeze and water.
5. Unplug washer or disconnect power.

To use washer again:

1. Flush water pipes and hoses.
2. Reconnect water inlet hoses.
3. Turn on both water faucets.
4. Plug in washer or reconnect power.
5. Run the washer through a complete cycle with 1 cup (250 mL) of detergent to clean out anti-freeze.

Non-use or vacation care:

Operate your washer only when you are at home. If you will be on vacation or not using your washer for an extended period of time, you should:

- Unplug the power supply cord or turn off electrical power to the washer.
- Turn off the water supply to the washer. This helps avoid accidental flooding (due to a water pressure surge) while you are away.

INLET HOSES

Replace inlet hoses after 5 years of use to reduce the risk of hose failure. Inspect and replace inlet hoses if bulges, kinks, cuts, wear, or leaks are found.

When replacing your inlet hoses, mark the date of replacement on the label with a permanent marker.

TROUBLESHOOTING

COMMON WASHING PROBLEMS

Problem...	Cause...	Solution ...
Washer leaks NOTE: After checking these, check household plumbing.	<ul style="list-style-type: none"> ● Fill hoses not tight. ● Fill hose washers not properly seated. ● Drain hose clamp not properly installed or is off. ● Drain is clogged. ● Tub moved forward during unloading, causing water to deflect off tub ring. ● Unit not level, causing water to deflect off tub ring. ● Fill or spray rinses are deflecting off load. Washer is overloaded or load is unbalanced. 	<ul style="list-style-type: none"> ● Tighten hoses. See Installation Instructions. ● Reseat (reposition) washers. See Installation Instructions. ● Clamp drain hose. ● Unclog drain. Sink and standpipe must be able to handle 17 gallons (65 L) of water per minute. ● Ensure tub is centered before starting washer. ● Ensure front feet are installed and nuts are tightened. Level washer. ● Redistribute the load, or reduce load size.
Washer won't drain/spin	<ul style="list-style-type: none"> ● Drain hose is clogged. ● Lid is open. ● End of drain hose more than 72 inches (191 cm) above floor. ● Too much detergent – excessive sudsing. ● Low voltage or using an extension cord. 	<ul style="list-style-type: none"> ● Unclog hose. See Installation Instructions for proper installation of drain hose. ● Close the lid. ● Lower drain hose. ● Use less detergent. ● Check electrical source or call electrician. Do not use extension cords.
Wet loads	<ul style="list-style-type: none"> ● Wrong cycle for load being washed. ● Cold rinses. 	<ul style="list-style-type: none"> ● Choose a cycle with a higher spin speed. ● Cold rinses leave loads wetter than warm rinses. This is normal.
Washer continues to fill/drain or cycle stuck NOTE: Washer pauses briefly throughout each cycle. This is normal.	<ul style="list-style-type: none"> ● Top of drain hose is lower than water level in washer. ● Drain hose fits too tightly into standpipe. ● Drain hose taped into standpipe. 	<ul style="list-style-type: none"> ● Raise the drain hose. It must be higher for proper operation. ● Adjust drain hose for loose yet secure fit. See Installation Instructions. ● Do not seal off drain hose with tape. The hose needs an air gap.
Washer makes noise	<ul style="list-style-type: none"> ● Load is unbalanced. ● Washer is not level. ● Nuts on front feet not tight. ● Yellow shipping strap with cotter pins not completely removed. ● Gears engaging after drain and before spin. 	<ul style="list-style-type: none"> ● Redistribute load. ● Level washer. Reset rear leveling legs. See Installation Instructions. ● Tighten nuts. ● See Installation Instructions. ● This is normal.

COMMON WASHING PROBLEMS (CONT.)

Problem...	Cause...	Solution...
Won't fill/rinse/agitate or wrong temperature	<ul style="list-style-type: none"> ● Power cord not plugged in. ● Timer (Cycle Control knob) dial is not lined up. ● Water inlet valve screens are plugged. ● Water is turned off. ● Hot and cold hoses are reversed. ● Inlet hose is kinked. 	<ul style="list-style-type: none"> ● Plug in power cord. ● Turn timer knob to the right slightly and pull to start. ● Clean screens. ● Turn on water. ● Reverse hoses. ● Straighten hose.
Washer stops	<ul style="list-style-type: none"> ● Power cord not plugged in. ● No power at plug. ● Fuse blown or circuit breaker open. ● Using an extension cord. ● Timer dial is not lined up. ● Timer knob not pulled out. ● Machine is overloaded. 	<ul style="list-style-type: none"> ● Plug in power cord. ● Check electrical source or call electrician. ● Replace fuse or reset circuit breaker. If problem continues, call electrician. ● Do not use extension cords. ● Turn timer to the right slightly and pull to start. ● Set and pull out knob. ● Wash smaller loads.
Water level seems too low or washer not completely filling	<ul style="list-style-type: none"> ● The top of the agitator is much higher than the highest water level. This creates a perception of the washer not being full. 	<ul style="list-style-type: none"> ● This is normal.
Washer tub is crooked	<ul style="list-style-type: none"> ● Tub is pulled forward when unloading. ● Tub moves. ● Unit not level. 	<ul style="list-style-type: none"> ● Push tub to center before starting. ● This is normal. ● Ensure front feet are installed and nuts tightened. Level washer. Reset rear leveling legs. See Installation Instructions.
Residue or lint on load	<ul style="list-style-type: none"> ● Improper sorting. ● Overloading. ● Paper or tissue in pockets. ● Not enough detergent. ● Detergent not dissolving. ● Wash water colder than 70°F (21°C). 	<ul style="list-style-type: none"> ● Sort lint givers (towels, chenille) from lint takers (corduroy, synthetics). Also sort by color. ● Lint can be trapped in load if overloaded. Wash smaller loads. ● Clean out pockets before washing. ● Use enough detergent to hold lint in water. ● Use wash water warmer than 70°F (21°C). ● Use wash water warmer than 70°F (21°C).

continued on next page

COMMON WASHING PROBLEMS (CONT.)

Problem...	Cause...	Solution...
Tearing	<ul style="list-style-type: none"> ● Overloading. Improper use of washer. ● Improper use of chlorine bleach. ● Sharp items not removed from pockets; fasteners not fastened. ● Items damaged before washing. 	<ul style="list-style-type: none"> ● Loads should move freely during wash. Wash smaller loads. ● Do not pour chlorine bleach directly on load. Wipe up bleach spills. Undiluted bleach will damage fabrics. ● Clean out pockets before washing. Zip zippers before washing. ● Mend rips and broken threads in seams before washing.
Stains on load	<ul style="list-style-type: none"> ● Improper use of fabric softener. ● Iron (rust) in water. ● Not enough detergent used, causing soil to be redeposited. ● Dye transfer due to not sorting loads properly. ● Dye transfer due to not unloading washer promptly. 	<ul style="list-style-type: none"> ● Dilute fabric softener and add to rinse portion of cycle only. Do not drip fabric softener on clothes. ● Install an iron filter. ● Use enough detergent to remove soil and hold it in suspension. ● Sort dark clothing from whites and lights. ● Unload the washer as soon as it stops.
Load is wrinkled	<ul style="list-style-type: none"> ● Not removing load promptly. ● Wrong cycle for fabrics being washed. ● Overloading. ● Wash water not warm enough to relax wrinkles. Using warm rinses. ● Hoses reversed. 	<ul style="list-style-type: none"> ● Unload the washer as soon as it stops. ● Use the Permanent Press cycle to reduce wrinkling. ● Loads should move freely during wash. Wash smaller loads. ● If safe for fabric, use warm or hot wash water. Use cold rinse water. ● Reverse hoses.
Load is tangled/twisted	<ul style="list-style-type: none"> ● Overloading. ● Clothes wrapped around agitator. 	<ul style="list-style-type: none"> ● Loads should move freely during wash. Wash smaller loads. ● Do not wrap items around agitator.
Gray whites, dingy colors	<ul style="list-style-type: none"> ● Dye transfer. ● Wash temperature too low. ● Not enough detergent. ● Hard water. 	<ul style="list-style-type: none"> ● Sort dark clothes from whites and lights. ● Use hot or warm washes, if safe for fabric. Hot water should be at least 111°F (44°C) to clean heavy or greasy soils. ● Use more detergent for washing heavy soils in cold or hard water. ● Use more detergent when washing in hard water.

ASSISTANCE OR SERVICE

IF YOU NEED ASSISTANCE OR SERVICE IN THE U.S.A.

Call our Consumer Assistance Center toll free at 1-800-447-6737. Our consultants are available to assist you.



When calling:

Please know the purchase date, and the complete model and serial number of your appliance (see "A Note to You" section). This information will help us better respond to your request.

Our consultants provide assistance with:

- Features and specifications on our full line of appliances
- Installation information
- Use and maintenance procedures

- Accessory and repair parts sales
- Specialized customer assistance (Spanish speaking, hearing impaired, limited vision, etc.)
- Referrals to local dealers, service companies, and repair parts distributors.

To locate the designated service company in your area, you can also look in your telephone directory Yellow Pages.

IF YOU NEED REPLACEMENT PARTS

If you need to order replacement parts, we recommend that you only use FSP® factory specified parts. These parts will fit right and work right, because they are made to the same exacting specifications used to build every new ROPER® appliance.

To locate FSP replacement parts in your area, call our Consumer Assistance Center telephone number or your nearest designated service center.

FOR FURTHER ASSISTANCE

If you need further assistance, you can write to us with any questions or concerns at:

Roper Brand Home Appliances
Consumer Assistance Center
c/o Correspondence Dept.
2000 North M-63
Benton Harbor, MI 49022-2692

Please include a daytime phone number in your correspondence.

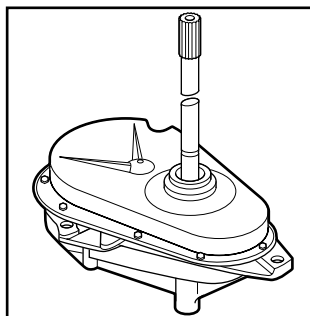

Gearcase assembly covered by your warranty.

IF YOU NEED ASSISTANCE OR SERVICE IN CANADA

1. If the problem is not due to one of the items listed in "Troubleshooting"*

Contact the dealer from whom you purchased your appliance, or call the Inglis Limited Consumer Relations Department toll free, **8:30 a.m. – 6 p.m. (EST)**, at **1-800-461-5681**.



2. If you need service* ...

Contact Inglis Limited from anywhere in Canada at **1-800-807-6777**.

* When asking for assistance or service, please provide a detailed description of the problem, your appliance's complete model and serial numbers, and the purchase date. (See the "A Note to You" section.) This information will help us respond properly to your request.

IF YOU NEED REPLACEMENT PARTS

If you need to order replacement parts, we recommend that you only use FSP® factory specified parts. These parts will fit right and work right, because they are made to the same exacting specifications used to build every new Roper® appliance.

To locate FSP factory specified replacement parts in your area, call our Consumer Relations Department or your nearest designated service center.

FOR FURTHER ASSISTANCE

If you need further assistance, you can write to Inglis Limited with any questions or concerns at:

Consumer Relations Department
Inglis Limited
1901 Minnesota Court
Mississauga, Ontario L5N 3A7

Please include a daytime phone number in your correspondence.

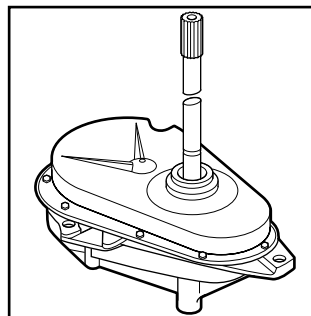

Gearcase assembly covered by your warranty.

ROPER[®] AUTOMATIC WASHER WARRANTY (U.S.A.)

LENGTH OF WARRANTY	WHIRLPOOL CORPORATION WILL PAY FOR
FULL ONE-YEAR WARRANTY FROM DATE OF PURCHASE	FSP [®] replacement parts and repair labor to correct defects in materials or workmanship. Service must be provided by a Roper designated service company.
LIMITED 2ND-5TH YEAR WARRANTY FROM DATE OF PURCHASE	FSP replacement parts for any part of the gearcase assembly if defective in materials or workmanship.
WHIRLPOOL CORPORATION WILL NOT PAY FOR	
<p>A. Service calls to correct the installation of your washer, to instruct you how to use your washer, or to replace house fuses or correct house wiring and plumbing.</p> <p>B. Repairs when your washer is used in other than normal, single-family household use.</p> <p>C. Pickup and delivery. Your washer is designed to be repaired in the home.</p> <p>D. Damage resulting from accident, alteration, misuse, abuse, fire, flood, acts of God, improper installation, or installation not in accordance with local electrical and plumbing codes.</p> <p>E. Replacement parts or repair labor costs for units operated outside the United States.</p> <p>F. Any labor costs during the limited warranty.</p> <p>G. Repairs to parts or systems resulting from unauthorized modifications made to the appliance.</p>	

6/99

THIS ROPER APPLIANCE IS WARRANTED BY WHIRLPOOL CORPORATION. WHIRLPOOL CORPORATION SHALL NOT BE LIABLE FOR INCIDENTAL OR CONSEQUENTIAL DAMAGES. Some states do not allow the exclusion or limitation of incidental or consequential damages, so this exclusion or limitation may not apply to you. This warranty gives you specific legal rights, and you may also have other rights which vary from state to state.

Outside the United States, a different warranty may apply. For details, please contact your authorized Roper dealer.

If you need service, first see the "Troubleshooting" section of this book. After checking "Troubleshooting," additional help can be found by checking the "Assistance or Service" section.

For warranty information in Canada:

Please contact your authorized Roper dealer or call the Consumer Relations Department at **1-800-461-5681** (toll free) between 8:30 a.m. and 6 p.m. EST from anywhere in Canada.

For assistance or service in Canada:

If you need assistance or service in Canada, first see the "Troubleshooting" section of this book. After checking "Troubleshooting," additional help can be found by checking the "Assistance or Service" section.