

This Owner's Manual is provided and hosted by [Appliance Factory Parts](#).



# SUBZERO 700TFI-2 Owner's Manual

[Shop genuine replacement parts for SUBZERO  
700TFI-2](#)



[Find Your SUBZERO Refrigerator Parts - Select From 117 Models](#)

----- Manual continues below -----

**700TF/I-2 & 700TF/I-2V DOOR & DRAWER VIEW PARTS LIST**

<u>Ref #</u>	<u>Part #</u>	<u>Description</u>
1	4202011	Door Assy, RH ( <i>Hinges &amp; Shelves not include</i> )
	4202012	Door Assy, LH ( <i>Hinges &amp; Shelves not include</i> )
2	3211510	Door Gasket
3	0183610	Door Panel Brkt-Handle Side
4	6200720	Screw, #8-18 x 1/2 PH Truss HD
5	0183600	Door Panel Brkt-Hinge Side
6	6201500	Screw, #10X3/4 Drill PH Hex Was
7	3421490	Panel Bracket Cover
8	4181270	Door Shelf Assembly
9	0183580	Drawer Panel Bracket-Upper
10	0183590	Drawer Panel Bracket-Lower
11	4131720	Upper Drawer Front Assembly
12	3211520	Upper Drawer Gasket
13	3211560	Seal, Tub White 37-5/8"
14	3211540	Lower Drawer Gasket
15	4131750	Lower Drawer Front Assy
16	6200110	Screw, #10-12 x 5/8" Truss SS
17	3414020	Divider, Top Drawer
18	3414000	Tub, Upr Drawer
19	3414010	Tub, Lwr Drawer
20	4134410	Drawer Assy, Top
21	4134420	Drawer Assy, Bottom w/IM
22	3414030	Divider, Bottom Drawer
23	6200710	Screw, #8-18 x 3/8" Fillister HD
24	3511040	3" Wire Pull (with IM only)
25	6200080	Screw, #8-15 x 1/2" Truss HD (with IM only)
	3550400	Hole Plug (w/o IM only)
26	3412420	Filler Plate, Drawer Tub Lower (w/o IM only)

**NOTE:** Door/Drawer panels on this model are a sales accessory. For part numbers of complete door panel sets or components of the door panel sets, contact the factory.

**700TF/I-2 & 700TF/I-2V DOOR & DRAWER VIEW**

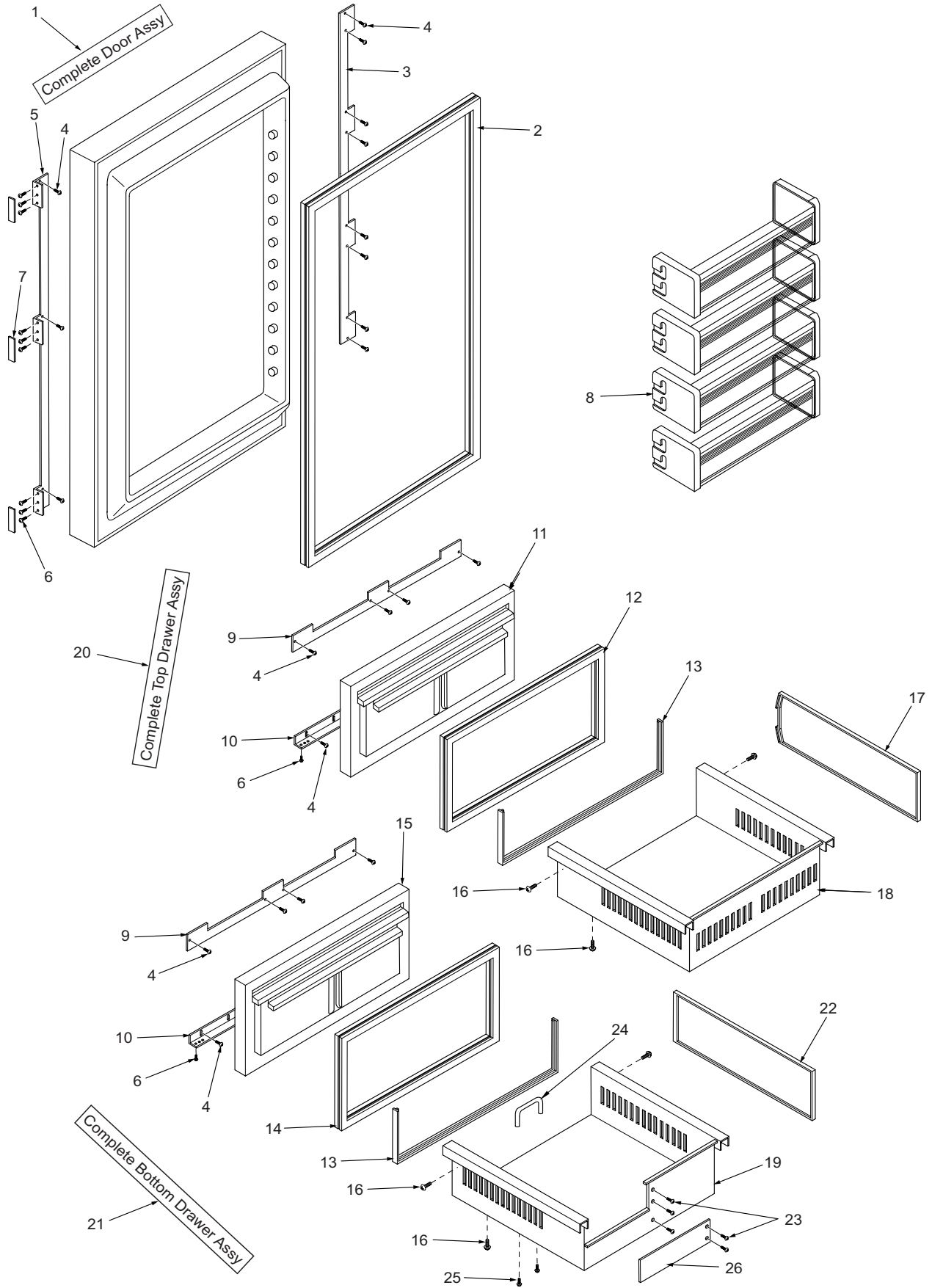



**700TF/I-2 & 700TF/I-2V COSMETIC VIEW PARTS LIST**

<u>Ref #</u>	<u>Part #</u>	<u>Description</u>	<u>Ref #</u>	<u>Part #</u>	<u>Description</u>
1	6200010	Screw, #10-12 x 3/4" Pan HD	22	0167661	Kickplate Bracket - RS
2	0212470	Box, Ref Switch		0167662	Kickplate Bracket - LS
3	3450920	Bracket, Switch Mounting		6200780	Screw, #10-24 x 1/2" PH Hex Wash
4	6200210	Screw, #8-32 x 1/2" Flat Head	23	6200050	Screw, #10-12 x 1/2" Pan HD
5	3516010	Molding, Side	24	3530430	Kickplate/Grille
6	3421510	Bracket, Unit to Cabinet	25	6201120	Screw, #8-18 x 1.75 Truss SS
7	6200720	Screw, Tap, #8 x 1/2" PH FL HD	26	6201330	Screw, #8 PH-Pan Head 1"
8	3520420	Insert / Diffuser Stand-off	27	0168880	Pan, Drain
9	4161140	Light Diffuser Assy	28	4134410	Drawer Assy, Top
10	3516451	Molding, Top RH	29	4134420	Drawer Assy, Bottom w/IM
	3516452	Molding, Top LH	30	0234680	Cover, Heat Exchanger
11	3602320	Shelf, Glass Cantilever	31	3412080	Ice Bucket
12	3602270	Shelf Ladder, Left	32	3511040	3" Wire Pull (with IM only)
13	6200710	Screw, #8-18 x 3/8" Fillister HD	33	6200080	Screw, #8-15 x 1/2" (with IM only)
14	3602280	Shelf Ladder, Right		3550400	Hole Plug (w/o IM only)
15	6201270	Screw, #8-18 x 5/8" PH PN SS-Gnd	34	3412420	Filler Plate, Drawer (w/o IM only)
16	3541020	Drawer Closer	35	6200710	Screw, #8-18 x 3/8" Fillister HD
17	6200110	Screw, #10-12 x 5/8" Truss SS	36	4181330	Lower Glass Tray
18	3550720	White Thread Pin	37	4161310	Cold Plate Assy, Lower
19	4134430	Drawer Assy, Slide-RH	38	0260350	Enclosure, Switch
20	6201140	Screw, 1/4-20 x 1/2" Sems But HD	39	4281130	Cold Plate Assy, Upr
21	4134440	Drawer Assy, Slide-LH	40	4152070	Trim Assy, Top

**NOT PICTURED**

3580170	Nameplate
3754220	Door Panel Drilling Template
3421460	Bracket-Unit to Unit

**700TF/I-2 & 700TF/I-2V COSMETIC VIEW**

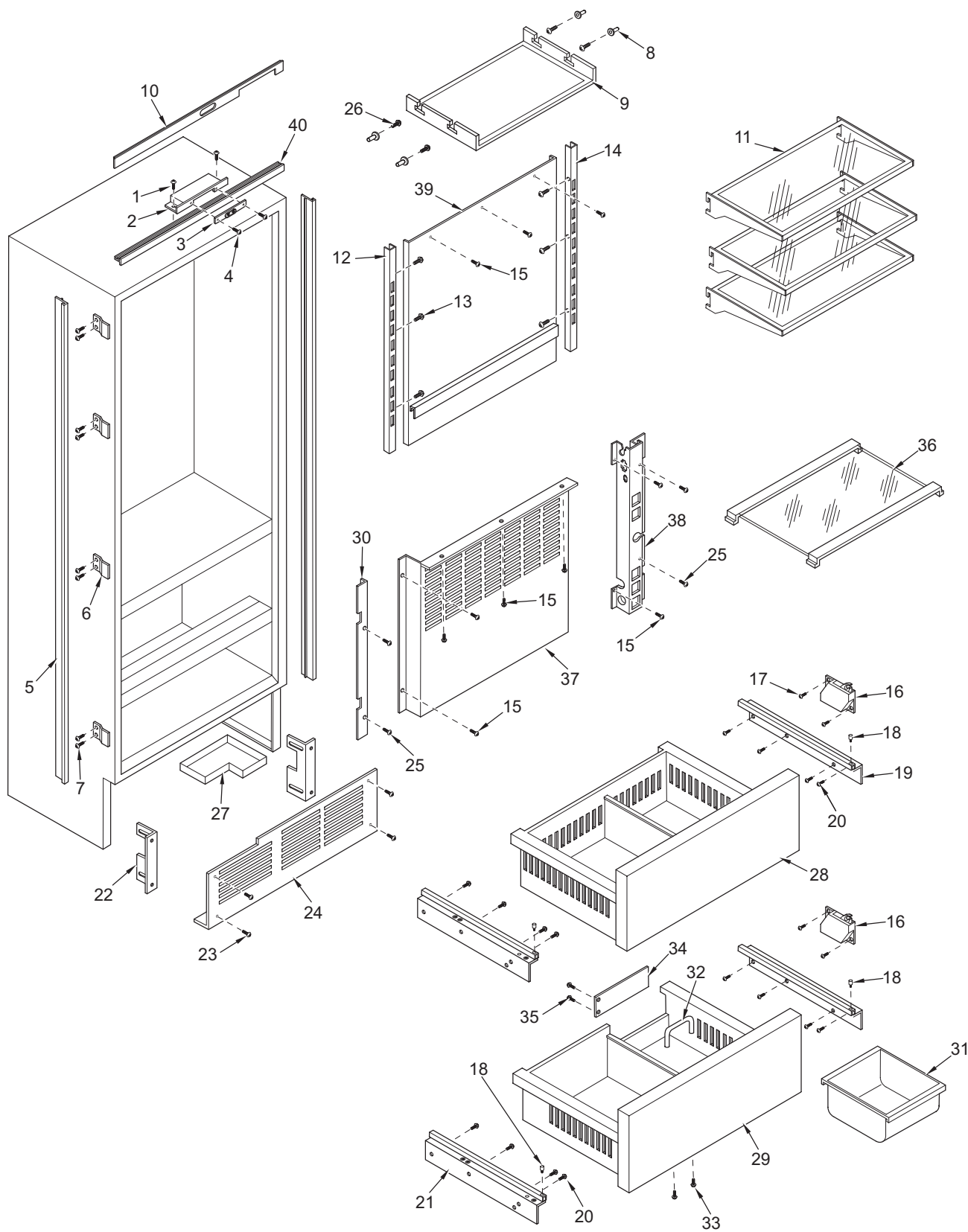



700TF/I-2 & 700TF/I-2V MECHANICAL VIEW PARTS LIST

Ref #	Part #	Description	Ref #	Part #	Description
1	6200010	Screw, #10-12 x 3/4" Pan HD	48	6201270	Screw, #8-18 x 5/8" PH PN SS-Gnd
2	0212470	Box, Ref Switch	49	4203320	Pckg, Cntrl Board (See SN Breaks)
3	3450920	Bracket, Switch Mounting		4203520	Pckg, Cntrl Board (See SN Breaks)
4	6200210	Screw, #8-32 x 1/2" Flat Head		4203790	Pckg, Cntrl Board (See SN Breaks)
5	3060030	Light Switch, N/C		4324860	Wire Hrns,Cntl Brd (See SN Breaks)
6	3060020	Fan Switch, N/O	50	4152050	Cover Assy, Control
7	3541050	Hinge Cover	51	6201270	Screw, #8-18 x 5/8" PH PN SS-Gnd
8	3541031	Hinge Assy, TOP - RH	52	3060140	SPST Light Switch
	3541032	Hinge Assy, TOP - LH	53	3060130	SPST Fan/Icemaker Switch
	3541041	Hinge Assy, MDL - RH	54	4324890	Heater Assy, Defrost
	3541042	Hinge Assy, MDL - LH	55	1801100	Heater Clip
9	6201140	Screw, 1/4-20 x 1/2" Sems But HD	56	3070150	Heater, Drain Trough
10	6200780	Screw, #10-24 x 1/2" PH Hex Wash	57	0234620	Bracket, Heater
11	3050010	Light Socket, 3/4 Sngl (See SN Breaks)	58	2600617	Plastic Water Line
	3050220	Skt,Light Int Base Sngl(See SN Breaks)	59	3520030	Icemaker Nylon Nut, 1/4"
12	3030060	Light Bulb, 25 Watt	60	3520050	Brass Insert, Solenoid
13	4134430	Drawer Assy, Slide-RH	61	4202790	Water Valve
14	3550720	White Thread Pin	62	6200780	Screw, #10-24 x 1/2" PH Hex Wash
15	6201140	Screw, 1/4-20 x 1/2" Sems But HD	63	2604194	Tube, Water Line
16	4134440	Drawer Assy, Slide-LH	64	6120450	Locking Cable Tie 9.7" BLK
17	3541020	Drawer Closer	65	3013820	Fill Tube Heater
18	6200110	Screw, #10-12 x 5/8" Truss SS	66	1607600	Water Inlet Tube
19	4324800	Retractor Assy, Power Cord	67	6220470	Fill Tube Clamp
20	NA	See 4202000	68	2605405	Fill Tube Extension
21	3421500	Adjusting Rod	69	4200520	Modular Icemaker
22	NA	NA	70	0167700	Bracket, Icemaker
23	4202000	Rear Leveler Assembly		6120360	Snap-in Wire Clip (Not Shown)
24	3570060	Bolt, Leveler 3/8-16	71	6201000	Screw #8-32X3/8 Thread Forming
25	4281310	Shroud Assy, Cond Fan	72	6220220	Screw Grommet, 1/32 x 3/8" SQ
	3220370	Grommet, 1/4" X 3/16" (Not Shown)	73	6120280	Clamp, Tube Nylon 3/16"
26	6200010	Screw, #10-12 x 3/4" Pan HD	74	6200140	Screw, #8-15 x 3/8" Truss HD
27	3220360	Grommet, Mtg Brkt	75	3140300	Icemaker Control Arm
28	6201000	Screw #8-32X3/8 Thread Forming	76	3421070	Rod, Connecting
29	0167430	Cond Fan Mtg Brkt (3 Required)	77	3082090	Defrost Terminator
30	4200740	Motor Pkg, Cond Fan	78	4200160	Fre Fan Motor
31	3150320	Fan Blade, Cond -5 prop, 7"	79	3150570	Fan Blade (See SN Breaks)
32	6150410	Nut, 1/4-20		3150640	Fan Blade (See SN Breaks)
33	6201010	Screw, #8-15 x 2" Pan Head	80	4162610	Control Panel Assy
34	3030030	Light Bulb, 40 Watt	81	0260350	Enclosure, Switch
35	3050180	Light Socket, Dbl (See SN Breaks)		4161290	Switch Enclsr Assy (700TFI-2, 700TFI-2V)
	3050250	Skt, Light M Base Dbl (See SN Breaks)		4161770	Switch Enclsr Assy (700TF-2, 700TF-2V)
36	6201270	Screw, #8-18 x 5/8" PH PN SS-Gnd	82	3520370	Compression Sleeve
37	4281140	Shroud Assy, Fan (See SN Breaks)	83	3520380	Compression Nut
	4230540	Shroud Assy, Fan (See SN Breaks)	84	3450290	Angle Bracket
38	6220540	Screw Grommet/Stand-off, 1.375	85	4203780	Motor Pkg, Cond. Fan, Slow Speed
39	3082140	Light Terminator	86	4281430	Shroud Assy, Cond Fan
40	6180010	Pop Rivet, 1/8"	87	6201440	Screw, #8-32 X 1-3/4 Phil Hd
41	3014350	Thermistor	88	3210340	Neoprene Silencer, 7/8"
42	6201470	Screw, #8-32X3/4 SS	89	6201450	Nut, #8-32
43	6150850	Wellnut, #8-32	90	4203770	Box, Control, VS Compressor
44	0260370	Bracket, Fan	91	6150410	Nut, 1/4-20
45	6110270	Bolt, #10-32 x 1/4" RD HD	92	6240040	Flat Washer, 1/4"
46	6160240	Nylon Spacer			
47	6200720	Screw, Tap, #8 x 1/2" PH FL HD			

**NOT PICTURED**

0167550 Anti-Tip Bracket

**700TF/I-2 & 700TF/I-2V MECHANICAL VIEW**

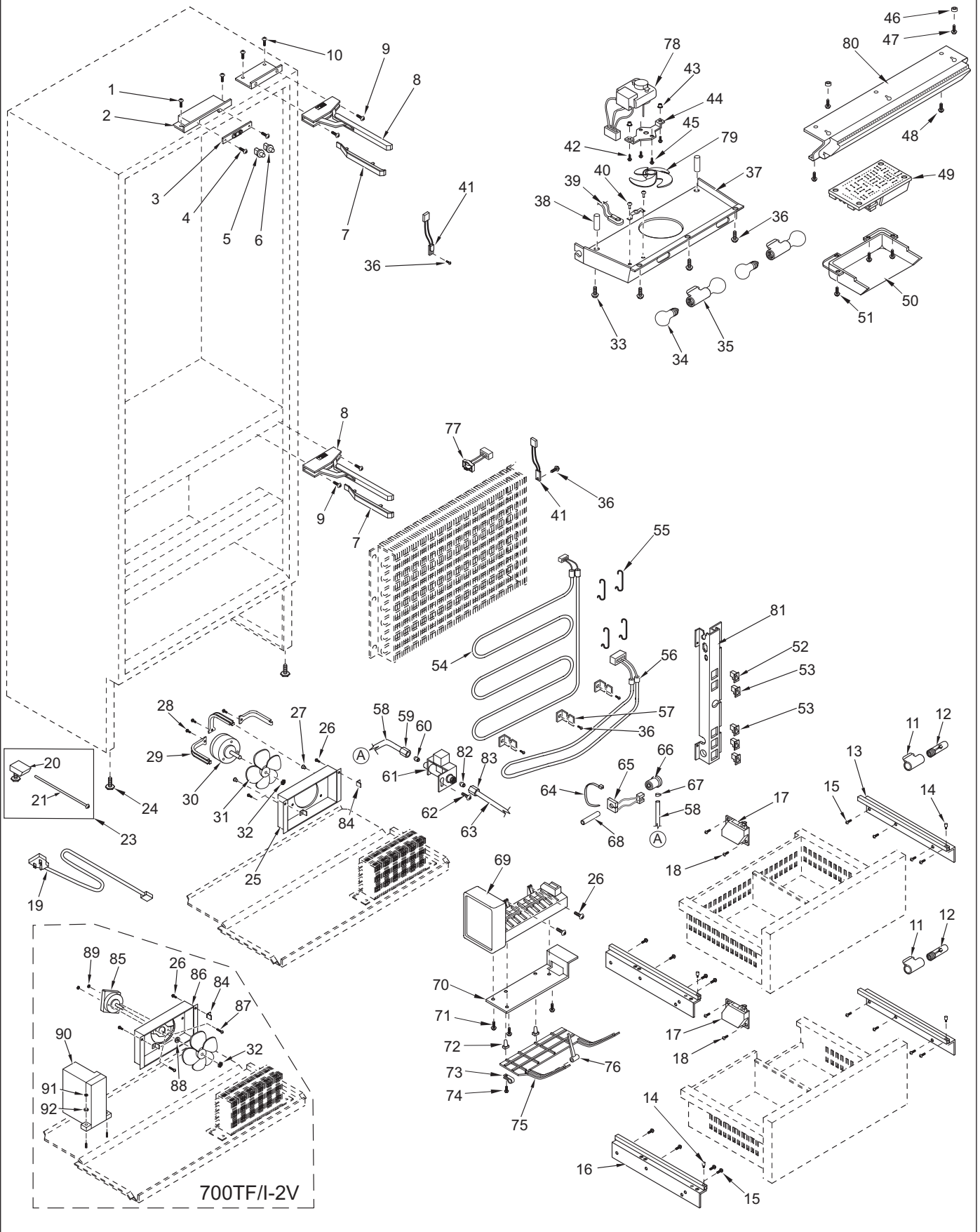

**700TF/I-2 & 700TF/I-2V SEALED SYSTEM VIEW PARTS LIST**

<u>Ref #</u>	<u>Part #</u>	<u>Description</u>
1	4202250	Compressor, Freezer (DA73) for 700TF/I-2
	4203760	Comp, Variable Speed (EMB VEGT-7) for 700TF/I-2V
	3111350	Relay (For RG108 Comp)
	3111420	Overload (For RG108 Comp)
	3111133	Capacitor (For RG108 Comp)
	3111041	Relay (For DA 73 Comp)
	3111430	Overload (For DA 73 Comp)
	3111070	Capacitor (For DA 73 Comp)
	3111212	Relay (For EGU80HLC Comp)
	3111620	Overload (For EGU80HLC Comp)
	3111270	Capacitor (For EGU80HLC Comp)
	4323520	Wire Harness, Run Capacitor (For RG108 Comp)
	0167620	Capacitor Mount Bracket
2	4251510	Heat Exchanger, Fre
3	6150220	Nut, 5/16-18 Hex Zinc
4	6240090	Lock Washer, 5/16"
5	6240050	Flat Washer, 5/16"
6	6160070	Sleeve, 5/16 x 7/16 x 7/8"
7	3150170	Rubber Grommet, Large, 15/16"
8	4311110	Unit Tray Assembly
9	3120400	Condenser
10	6150080	Nut-Flat, #10-24
11	6110020	Bolt, #10-24 x 3/8" Truss HD
12	3130540	Evaporator, Freezer
13	6201270	Screw, #8-18 x 5/8" PH PN SS-Gnd
14	3014230	Filter-Drier, High Side
15	0260340	Bracket, Drier

**NOTE:** For 700TF/I-2V Compressor Controller, see Mechanical View

**700TF/I-2 & 700TF/I-2V SEALED SYSTEM VIEW**

