

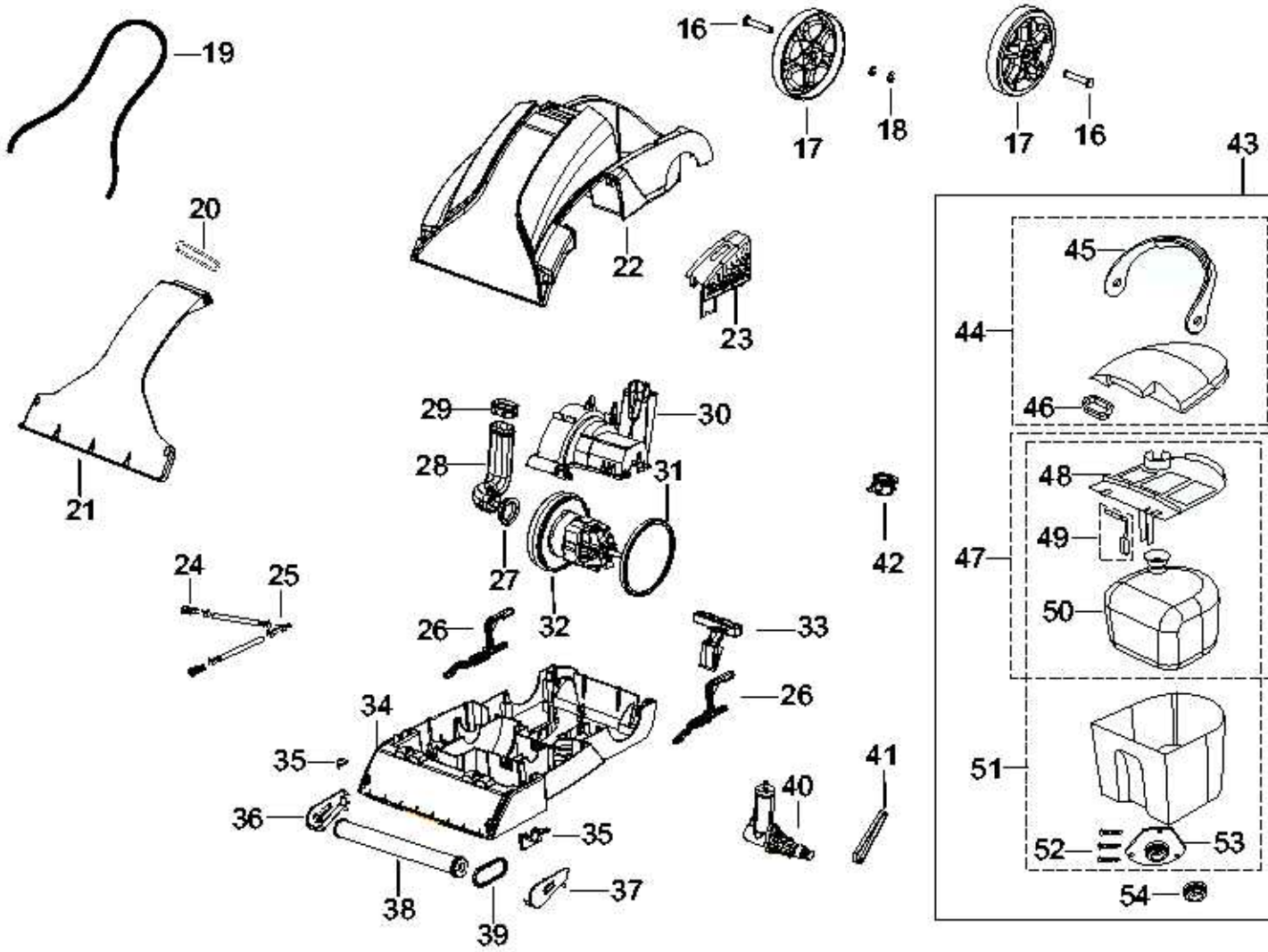

Upright Deep Cleaner

Model 1694-3

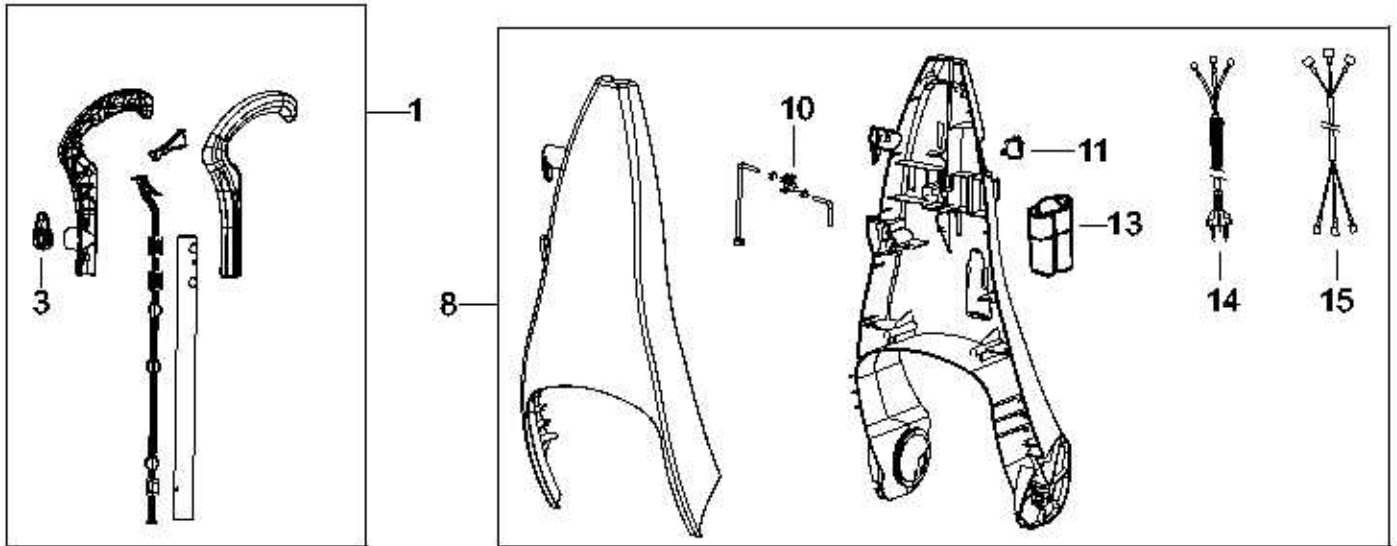

UPRIGHT DEEP CLEANER
POWERSTEAMER MODEL 1694-3



KEY	PART NO	DESCRIPTION	KEY	PART NO	DESCRIPTION
1	5556203	HANDLE & GRIP ASSY JAVA BEAN	40	2107181	PUMP
3	2106379	CORD WRAP, JAVA BEAN	41	2150628	PUMP BELT
8	2155102	LOWER HANDLE COMP, JAVA BEAN	42	2140710	AUTOLOAD RECEIVER
10	2109592	VALVE ASSY W/ VINYL TUBE	43	0159043	TANK ASSY W/ LINT SCN
11	5559125	SWITCH ROCKER, RED	44	0154439	TANK LID W/ SCN, GASKET, & HANDLE
13	2133010	MEASURING CUP	45	2034435	TANK HANDLE
14	2102836	CORDSET	46	2133501	LINT SCREEN, RED
15	2104446	HARNES W/ INS TERMINALS	47	2140213	BAFFLE & BLADDER ASSY
16	2100170	AXLE	48	2130213	BAFFLE & FLOAT ASSY
17	2139754	WHEEL	49	2140325	FLOAT ASSY
18	2106215	AXLE E-RING	50	2100315	BLADDER
19	2103418	GASKET EXTRUDED .136" x 32"	51	2149045	TANK BOTTOM W/ AUTOLOAD
20	2104052	TANK INTERFACE SEAL	52	2807075	SCREW #6 x 1/2
21	2149872	WINDOW NOZZLE	53	2107041	AUTO LOAD ASSY
22	2134942	MAIN HOUSING, JAVA BEAN	54	2106241	OVERSEAL FOR AUTOLOAD
23	2132901	BELT COVER, JAVA BEAN			
24	2106107	SPRAY TIP	xx	2102485	CLAMP LARGE
25	2102602	T - CONNECTOR	xx	2102490	CLAMP SMALL
26	2000010	LEVER ELEVATOR LEFT & RIGHT	xx	2102602	CONNECTOR T
27	2104051	MOTOR INTAKE GASKET	xx	2139438	TUBE VINYL 20"
28	2103161	MOTOR DUCT	xx	2139449	TUBE VINYL 7.5"
29	2104050	DUCT GASKET	xx	2158001	T ASSY ODD BARB
30	2132984	MOTOR COVER	xx	2806301	HANDLE SCREW
31	2104056	MOTOR GASKET	xx	5557030	SCREW #8 x 3/4 6-PACK
32	0175972	MOTOR	xx	2102516	USER'S GUIDE
33	5559102	PEDAL - HANDLE RELEASE			
34	2130448	BASE W/ STATIONARY BRUSH			
35	5556206	ARM RETAINER RT & LT			
36	5559121	PIVOT ARM - RIGHT			
37	5559118	PIVOT ARM - LEFT			
38	2101174	BRUSH - 2 ROW			
39	0150621	BRUSH BELT			

JAVA BEAN = 1694-3