

INSTRUCTION MANUAL

FOR MODELS MobileMAX II & MobileMAX III High Performance Mobile Evaporative Coolers

1. *Safety Instructions*
2. *Assembly*
3. *Features*
4. *Operation*
5. *Maintenance*
6. *Replacement Parts*
7. *Troubleshooting*



***Read this manual before
operating the product***

WARNING: The warnings and safety instructions in this manual MUST be followed to reduce the risk of fire, electric shock, or injury, and to provide reasonable safety and efficiency in using this cooler.

The operator is responsible for following the warnings and instructions in this manual and on the cooler. Read the entire manual before using the cooler.

Restrict the use of this cooler to persons who read, understand, and follow the warnings and instructions in this manual and on the cooler. Never allow children to operate this cooler.

Failure to observe these warnings and instructions will void manufacturer's warranties and discharge manufacturer of all liability.

CAUTION:

Always disconnect the cooler from the power supply before commencing maintenance procedures.

During maintenance procedures : NEVER use a naked flame for any inspection or cleaning purposes as a fire could be caused as a result of a flame coming into contact with the cooler's structure.

Avoid Dangerous Situations: Protect the cooler from all sources of ignitions because polymers and filter pads will burn.

NEVER use a water hose to squirt the cooler's interior for cleaning as residual water could damage electrical components and create the risk of fire and/or electric shock to the user after re-assembly

Installation, Repair and Operation

• All installation and repair work must conform to local electrical, water supply, environmental codes, rules and regulations, and applicable national standards.

Ensure compliance with local regulations.

• Installation and repair work must be done by a licensed and qualified electrician and/or a qualified experienced heating, ventilation, air conditioning technician. All installation and repairs must be made with factory authorized parts only.

• Use only approved replacement parts for all electrical components. If in doubt about what replacement parts to use, **do not guess**, contact Convair Cooler Corporation.

Use of wrong replacement parts creates risk of severe electric shock and fire, which may result in serious property damage, personal injury or death.

• **Use only thermal overload protected pumps!** Water pumps may seize up and overheat, creating a fire risk. Pumps that have thermal overload protection are designed to shut off electricity to the pump if the pump seizes and overheats.

• **Use only water pumps with three pronged grounded plugs!** Use of ungrounded plugs creates risk of severe electrical shock and fire. Never use pumps with bare ended wires.

Water pump must be replaced with authorized pump models (See Appendix 1).

• **Use only evaporative cooler motors with thermal overload protection!** Evaporative cooler motors may seize up and overheat, creating a fire risk. Motors with thermal overload protection are designed to shut off the motor if motor seizes and See Appendix 1 for authorised replacement fan motors.

The following safety requirements should be met to ensure safe and reliable operation of your new cooler:

• **This cooler is not flame retardant. Polymers will burn if ignited, protect cooler from all sources of ignition (flame / electrical shorts).**

• Disconnect electrical power before servicing, cleaning or performing maintenance on the cooler. Turn OFF the isolating switch inside the cooler before installing, servicing, cleaning or performing maintenance on the cooler.

• Use only a voltage supply as shown on the name plate of the motor.

• Before servicing the equipment make certain children, people and animals are a minimum of 30ft. (10m) away from the work area.

• **Dress safely !**, Jewellery, loose clothing, clothing with loosely hanging straps, ties, tassels, etc., can be caught in moving parts.

• Keep loose hair, fingers and all other parts of the body away from openings and moving parts.

• Check the cooler before operation. Look for worn, loose, missing or damaged parts. Do not use the cooler until it is in proper working order.

- Avoid dangerous situations. Do not use in the presence of flammable liquids or gases to avoid creating a fire or explosion and/or causing damage to this cooler.
- Avoid any body contact with any grounded conductor, such as a metal pipe to avoid possibility of electric shock.
- Ground Fault Circuit Interrupter (GFCI) protection should be provided on the circuit used for this cooler. Receptacles are available having built-in GFCI protection and may be used for this measure of safety.
- Never drain the air cooler onto the floor. Connect a hose from the drain fitting to a drain or gutter. Water residue could stain or cause you to slip.
- Always use the correct tools.

This column is intentionally left blank

Removal & Replacement of Pad Frames

Each pad frame is clipped into the cooler and is removable by use of a medium screwdriver inserted into slots at the base of the sides and levered downwards (see Fig. 1 ,page 4). The side will then slide down and out of the cooler cabinet.

To replace the pad frame, ensure that it is the right way up, i.e. with the water channel upwards.

Then fit the side in and up at the top and then in at the bottom. Use the screwdriver again, and insert it between the bottom of the side and the pan/tank wall at the center, and lever upwards, until the side locks into place.

Fitting the Wheels

Two wheels and two castors (with brakes) are supplied with each MobileMAX. They are packed inside the cooler.

1. Remove the rear pad frame .
2. Remove the package of castors, wheels and fasteners from inside the cooler.
3. Carefully roll the cooler onto one side, onto a piece of carpet or cardboard so as not to damage the cooler.
4. Fit the two fixed wheels to the front of the mobile tank using the screws provided (screw type). It is not necessary to drill holes for these screws. **DO NOT OVERTIGHTEN.**

WARNING:
The plastic covering this cooler can be a safety hazard
Please dispose of thoughtfully.

Warning :
Check to be sure that the voltage rating of the cooler components is compatible with your electrical voltage system

5. Fit the two steering castors to the rear of the mobile tank, etc.

6. Place the mobile tank on its wheels on the floor.

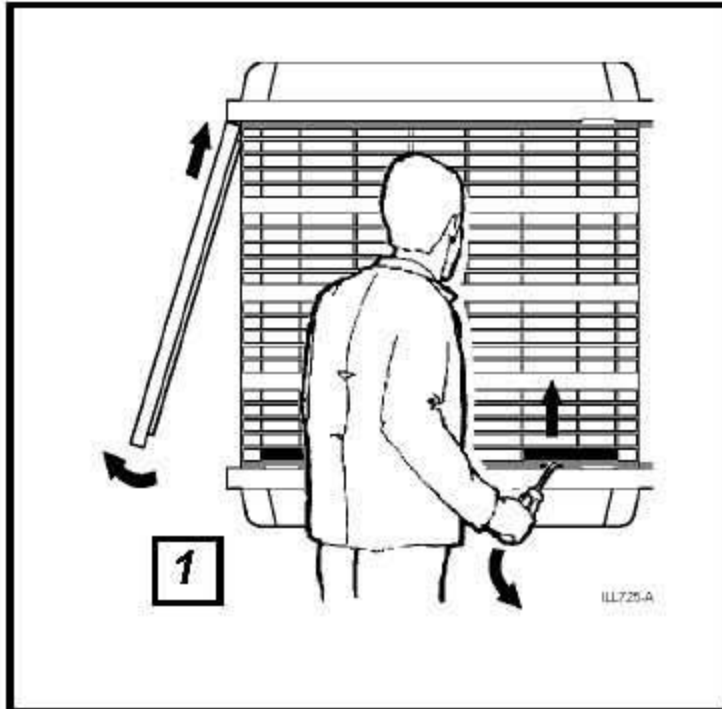

Section 3 - FEATURES

2 Speed Control

- Pump on and off
- Fan on and off
- Fan speed high and low

Adjustable Air Direction Louvres

- Left / right
- Up / down

Large Capacity Mobile Water Tank

- Front wheels
- Rear castors

Water Connections

- Float valve connection
- Manual filling funnel
- Tank drain fitting
- Water level indicator
- Plug
- Optional water connection

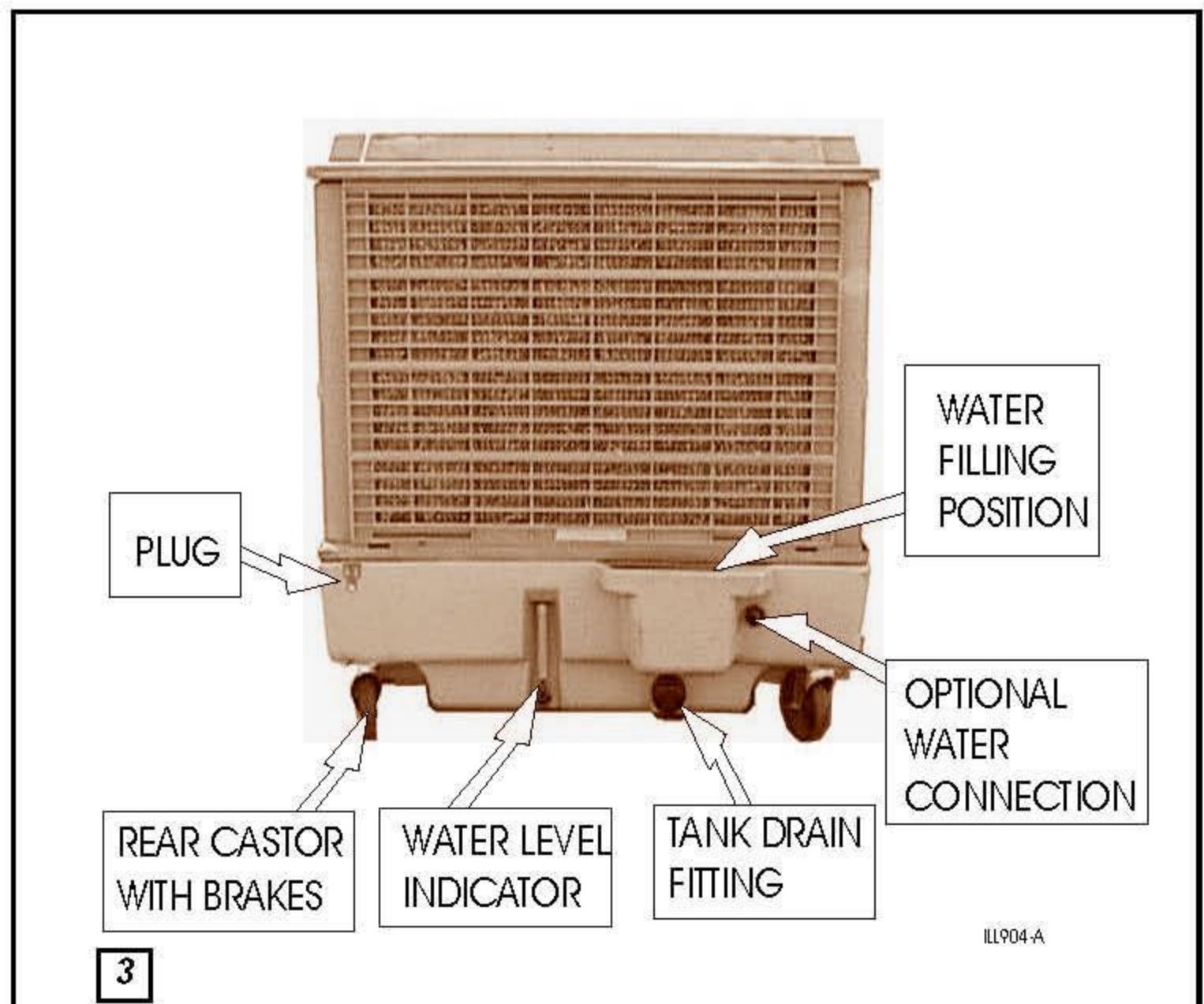



Section 4 - OPERATION & Section 5 - MAINTENANCE

Location & Orientation

When choosing a location for the cooler, maintain a safe distance from flame or other possible sources of ignition and ensure compliance with local regulations.

Using your Cooler

To operate effectively, evaporative air coolers always need to function on 100% fresh outside air. Always locate the cooler where it will receive a plentiful supply of fresh air and not in an area where it may be starved for air or where the air is polluted.

Open or provide exhaust outlets in the building you are cooling. Such outlets may be provided by the opening of doors and/or windows. Locate the cooler close to an opening but blowing into an area to be cooled.

If the design of your building does not allow such easy exhaust provisions, then you must install mechanical ventilation, such as an exhaust fan which can extract approximately 80% of the air that the cooler is discharging.

Generally, the higher the ambient relative humidity, the higher the air quantity required from the cooler. You should therefore control the speed of your cooler accordingly. On very dry days the cooler will give maximum cooling and this will decrease as the humidity increases.

Never allow cooler air to be discharged into a closed space, it must always be allowed to exhaust out.

You can keep your building cool for about 1/4 of the cost of refrigerated air conditioning.

The outlet grille for your Convair MobileMax has four way adjustable direction louvres.

Keep louvres as wide open as possible for maximum effect.

Cooler Operating Instructions

- Fill the tank, or if connected via a hose, turn on the water supply at the source.
- The Cooler's tank may be filled by bucket, hand-held hose or automatically via the float valve by connecting a high pressure hose.
- For extended pad life and effective cooling your Convair MobileMax needs a continuous supply of good quality water.
- Turn on the electrical power at the source.
- Wait ten (10) minutes for the water to fill the cooler pan/tank.
- Watch the water level indicator, do not overfill the tank at any time.
- Using the switch on the front of the cooler, turn on the pump only to properly wet the pads. Run for five (5) minutes.
- Select LOW fan speed at the fan switch.
- At times when the outside humidity is high, you may feel more comfortable by turning off the pump and running the fan only.
This will not cause any damage to the pump. High speed - no pump for high humidity, low speed - pump on low humidity.
- Ensure there are exhaust openings in the building.

Section 5 Maintenance

Allow for adequate access around the cooler when performing maintenance.

Provision must be made for access to electricity and water supplies.

Never force parts together, all parts are designed to fit together easily without undue force.

Pre-Season Maintenance

- Turn off the electric power supply.
- Turn off the water supply.
- Remove the pad frames.
- Fit new pads if necessary. The frequency of replacement depends on the condition of the environment and the water.

The pads supplied have been selected to give the highest possible cooling performance. Do not use alternatives. The manufacturer is not responsible for the performance of the cooler when alternative pads are used.

When replacing the pads, ensure the material is evenly distributed across the entire frame to a thickness of about 2". Regular "thin" pads will reduce the cooling efficiency of the cooler. Particular attention must be given to the corners of the pad frames. Avoid gaps and holes in the pad.

Daily Maintenance

- Drain the water from the tank and refill with fresh water

- If the pads are reused they can be easily cleaned by squirting them with a hose. Do not use excess pressure. This may create holes in the pad.
- Remove the pad from the pad frame, clean, and evenly redistribute the wood wool over the pad. Re-assemble the pad frame
- Inspect the pump and check that it will freely rotate by hand. If it is jammed with salt build-up, then remove it and clean it thoroughly. After cleaning the pump replace it into the cooler, making sure that it is securely in place.
- Check belt tension and adjust if necessary.
- Lubricate motor bearings (if oiler fitted) - only lightly.
- Replace the pad frames.
- Refill the tank.
- Restore electrical power supply and follow Operating Instructions.

In-Season Maintenance

DAILY:

- Drain the water from the tank and refill with fresh water.

MONTHLY:

- Turn off the electrical power supply.
- Remove the pad frames.
- Inspect the pads and clean or replace the material as required (see Pre-Season Maintenance).
- Check the water level and adjust the float if necessary.
- Check the pump operation.
- Clean the tank.
- Replace the pad frames.
- Restore electrical power supply and follow Operating Instructions.
- Check that the wood-wool is evenly distributed, and that there is no gaps.

End Season Maintenance

- Turn off electrical power supply.
- Turn off water supply if connected.
- Remove the pad frames. Hose them down carefully, do not use excess pressure as this may create holes in the pad material (see Pre-Season Maintenance).
- Remove and clean the special patented water "spreader plates" located under the top panel of the cooler, above each pad frame (see Fig. 12, page 10, item 43). When replacing them, ensure the spreader is correctly locating in the notches under the top panel, halfway along the side.

It should not be necessary to remove the spreader from the hoses, simply clean them at the cooler.

- Drain all the water from the cooler.
- Clean the bottom pan/tank thoroughly.
- Disconnect the water supply line. Leave disconnected until next season to prevent freezing and splitting.
- Replace the pad frames.
- Cover the cooler for the winter or store indoors.

Motor Power (Amps)

Your cooler is fitted with an adjustable motor pulley (sheave) to enable the cooler to provide maximum cooling. The adjustment of the pulley must be done by a trained, licensed technician using a clip on ammeter Maximum amps should not exceed the motor nameplate amps.

Install all pad frames, except the one on the motor side.

Set the cooler running at highest speed for approximately ten (10) minutes or until the motor has reached its normal operating temperature. **Motor load must be checked without the water pump running.**

Locate the motor current test wire in the terminal box. Measure the motor current using a clip-on ammeter (see Fig. 4, page 7). This should be done by a trained, licensed technician. Check the measured amps against the motor's nameplate rating.

If the measured amps are less than the nameplate amps the adjustable pulley may be altered to increase the fan speed, thereby delivering the full cooler capability to your installation. The measured amps should be equal or very close to the motor's nameplate amps (see heading Pulley [Sheave] Adjustment below).

If the measured amps are greater than the nameplate amps the fan must be slowed by adjusting the same pulley in the opposite direction. Failure to do this will overheat the motor which may result in a fire. Replace all covers when adjustments are complete.

Motor Pulley (Sheave) Adjustment

This adjustment is made with the cooler switched off. **Never attempt this adjustment with the cooler operating.**

Remove the drive belt.

To **increase** the fan speed and therefore increase the motor amps, the two halves of the motor pulley (sheave) must be closer together, i.e. turn the outer half **clockwise**. To decrease the fan speed and therefore decrease the motor amps, the two halves of the motor pulley must be further apart, i.e. turn the outer half **counter clockwise**.

The inner half of the motor pulley can be moved in or out by loosening the Allen screw. The outer half of the sheave is on a large thread and can be moved in or out in the desired direction.

If an adjustment is made, to the inner pulley half, tighten the Allen screw before replacing the belt and checking the amps.

Small adjustments should be made each time as you approach the desired setting (see Belt Tension).

Belt Tension

Belt tension is important. Tight belts will get excessive belt and bearing wear, and loose belts will slip with accompanying noise and loss of cooler performance.

To make the adjustment, loosen the locking nuts on the two adjusting bolts. Screw the bolts in or out as required to tighten or loosen the belt tension. When the adjustment is correct, tighten the locking nuts again.

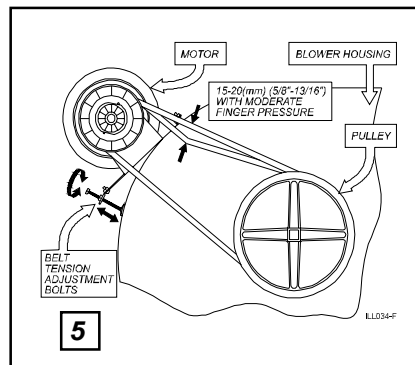
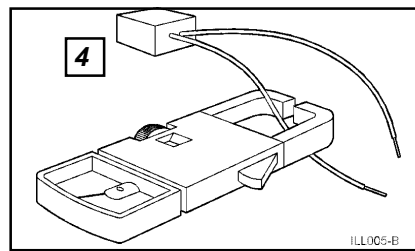

Water Pump

Water pump replacement note: This cooler is equipped with special safety circuits which constantly monitor the condition of the water pump motor. Should a fault develop in the pump motor the power supply to the cooler will be automatically turned off and the cooler will not run.

To ensure correct operation of this safety feature it is essential that only factory authorized replacement water pumps are used (see Appendix 1, page 15).

In addition to the integrated safety circuits, factory authorized pumps are equipped with thermal overload protection. Pumps that have thermal overload protection are designed to shut off the pump if the motor overheats.

Section 6 Replacement Parts

Factory Authorized Fan Motors

Replacement motors should have the same rating as the original motor. Only Factory Authorized Motors should be used. These are listed in Appendix 1, page 15.

Ensure that the replacement motor has thermal overload protection to avoid any risk of motor seizure, overheating and fire.

It is essential that the fan motor is in good order and is maintained in strict accordance with its manufacturer's recommendations. Never use motors which exhibit signs of mechanical or electrical malfunction.

Motor Connection (non Seeley motors)

The new cooler is supplied with a special motor cord . If replacing motor, remove cord from old motor and connect to new motor as follows:

- green / green-yellow - to motor grounding screw
- black - high speed
- red / brown - low speed
- white / blue - common / neutral.

WARNING:

Take care to ensure correct connection of fan motor. Incorrect connection can create a risk of electric shock or fire. Replace the electrical connection cover. Place the motor into the cradle so that the motor shaft protrudes at the same side as the fan pulley; fit the clamps (with the heads of the screws facing you) and tighten securely.

When placing the motor in the cradle, rotate it so that the vent holes are positioned in accordance with the motor manufacturer's recommendations. Ensure the cord is not stressed in any way. Take the adjustable aluminium motor pulley and slide it onto the motor shaft with the adjustable side of the pulley towards the end of the shaft, making sure that the Allen screw will tighten down onto the "flat" on the motor shaft. Now align the motor and fan pulleys. It is essential that the pulleys are correctly aligned. Poor alignment will cause excessive belt, pulley and bearing wear. The correct alignment of the pulleys and the tightening of the motor pulley (sheave) onto the "flat" of the shaft is most important to ensure successful transmission of the motor power (torque) to the fan and prevent slipping.

Electrical Installation

Wiring must comply with local codes and regulations and should only be carried out by a trained, licensed technician.

Wiring must be rated to carry at least the nameplate current

(amperes) of the fan motor and must be protected by a suitable fuse or circuit breaker. The main junction box is factory sealed, **do not attempt to open this junction box**, there are no field terminations or serviceable parts within.

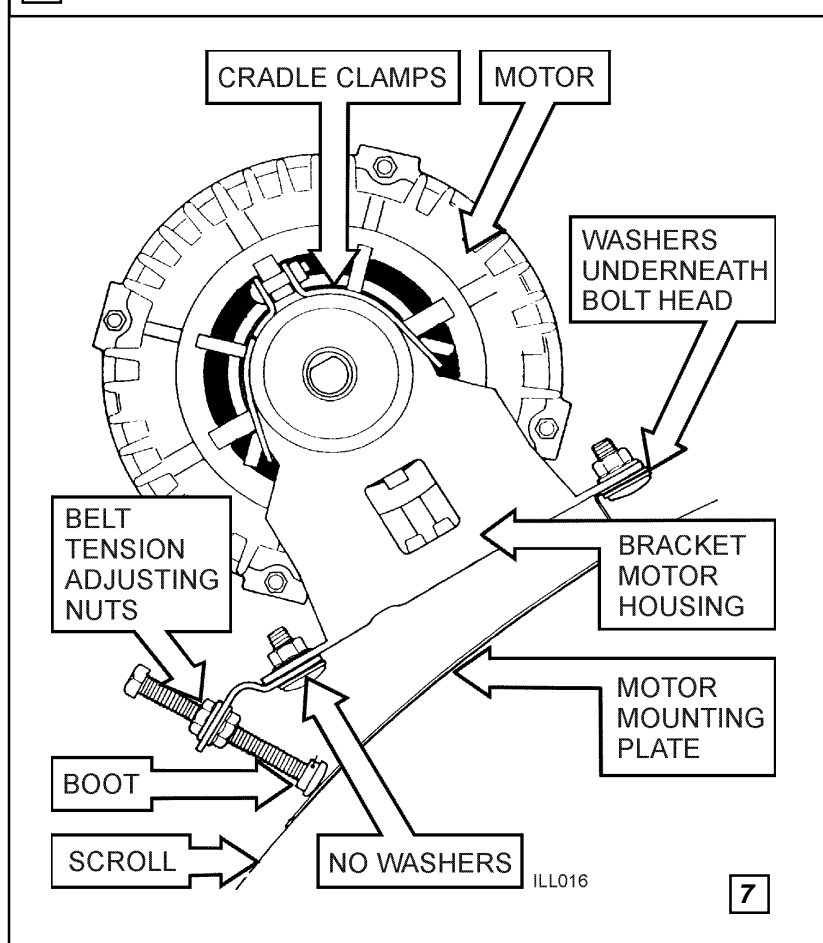
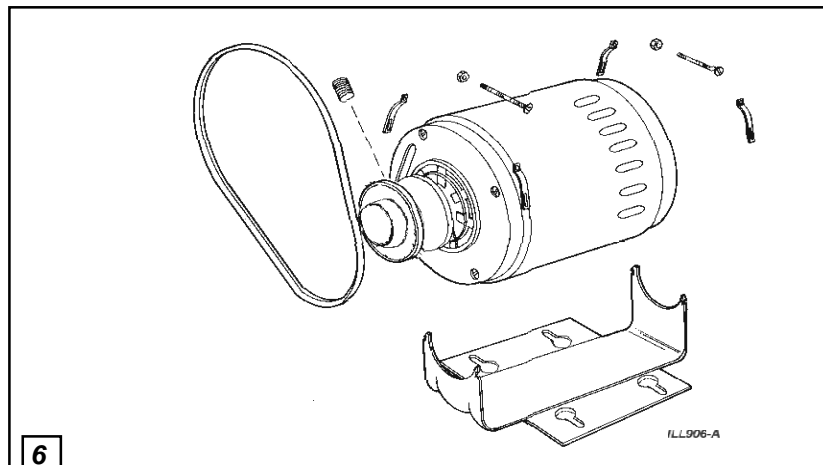

Ensure all electrical connections are tight. Loose connections cause overheating which can result in machine malfunction or fires.

The main junction box includes plug receptacles for the fire protection system, fan motor and water pump (see Fig. 14, page 15).

Note: The cord to the fire protection system must be plugged in before the cooler will operate. Any attempt to tamper with, or disable the fire protection system will render the cooler inoperative.

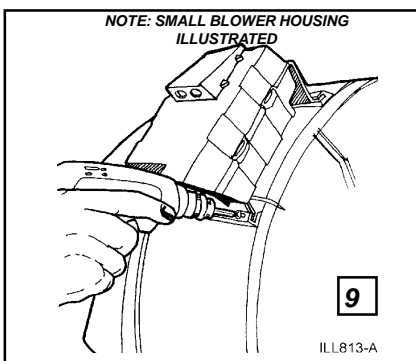
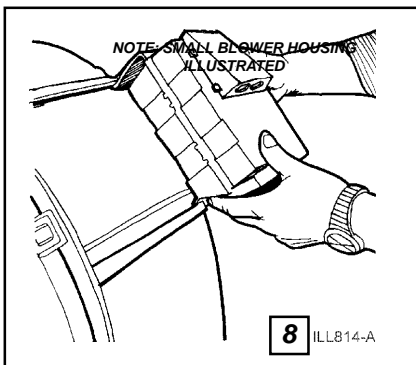

WARNING:
High voltage inside. Only use the screws supplied to replace the lid covering the external terminals.

Fan Bearing Replacement

Sometimes a fan shaft bearing will fail and must be replaced in the field. Before removal of the bearings, ensure you have a Bearing Kit (Part No. 800523).

The following procedure should be adhered to (see Fig. 27, and parts list):

To Remove Bearings

- Ensure electric power is disconnected.
- Remove belt.
- Remove small black plastic pin in pulley (use screwdriver as lever).
- Remove pulley. As you begin to extract the pulley depress the two bearing mount clips together (located inside the pulley boss) to allow it to slide along the shaft.
- Remove the black plastic bearing lock covering the bearing hub. (Use home-made tool from 3" diameter plastic pipe with notches cut to engage the cap), twisting it counter clockwise to remove.
- Use same tool to remove lock on other side of fan.
- Place a flat screwdriver across the corner of the bearing mount. Hit the screwdriver with a hammer until the bearing mount cracks. Once the part has cracked pull it from the bearing with a pair of pliers.
- Remove the bearing and its rubber resilient mount.

To Replace Bearings

- Fit new bearing/s over plastic square-to-round bearing mounts.
- Fit the rubber resilient mounts over the bearing/s.
- Clean the shaft and use a lubricant on the shaft for re-assembly
- Push the bearing assembly back up to its housing
- Ensure bearing clips are in place.
- Engage the bearing lock into its housing and twist it clockwise to lock.
- Push the pulley back onto the shaft, making sure the small hole in the pulley lines up with the small hole in the shaft. Insert clip
- Push the drive end bearing assembly hard up to its housing.
- Engage the bearing lock into the housing and twist it clockwise to lock.
- Using a block of wood and hammer, carefully drift the **non-drive** bearing assembly back on the shaft and into its housing until the plastic locator tap pops into its locating hole in the shaft.
- Replace the bearing lock (see previous instructions).
- Carefully centre the fan on the shaft and replace the plastic pins in the shaft either side of the fan.

Exploded Diagrams

Bearing

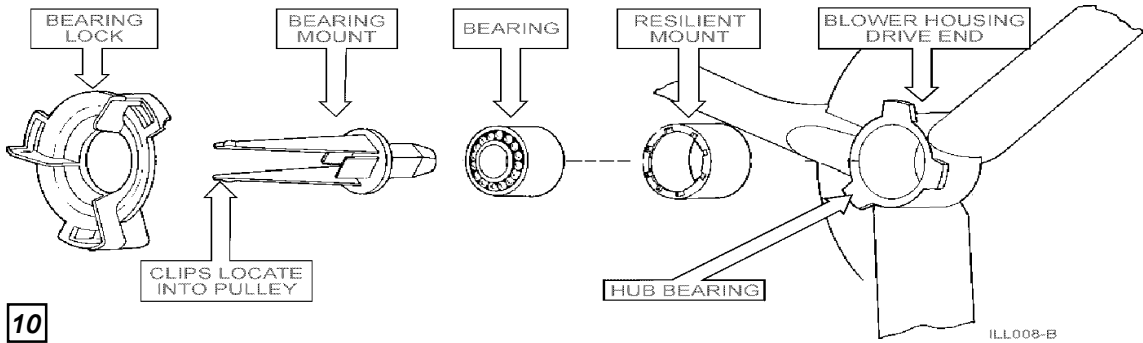

Drive System

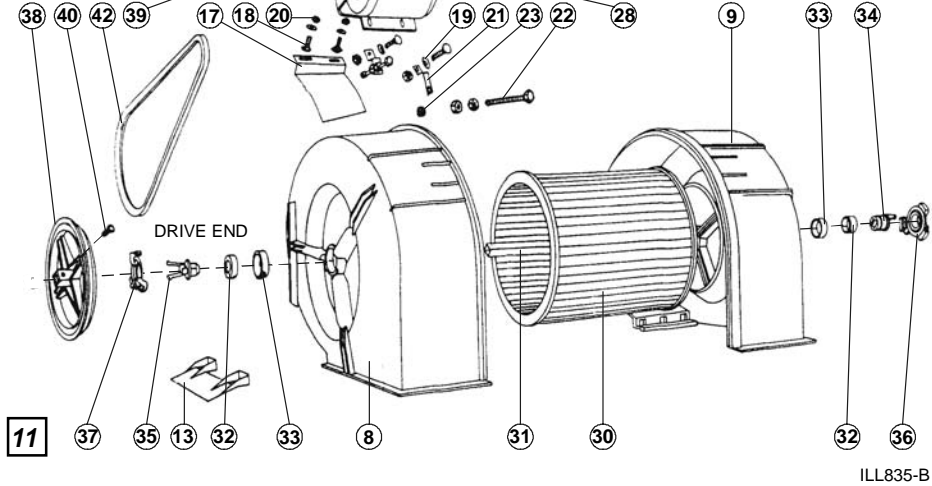

Unit

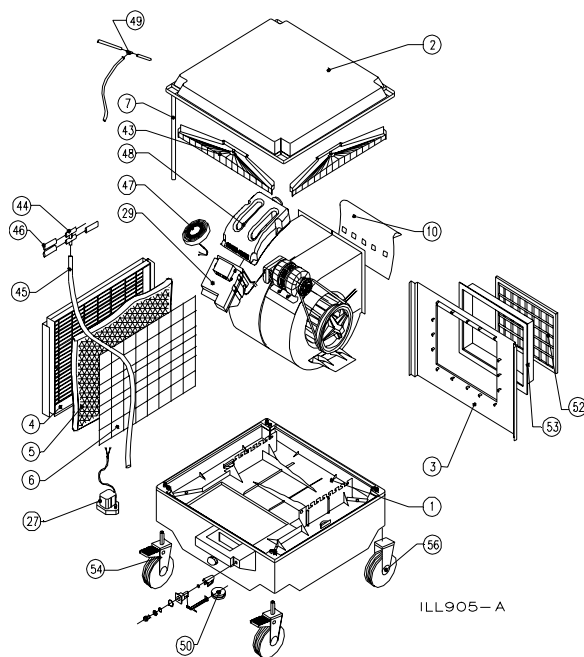

Section 6 - REPLACEMENT PARTS

ITEM	DESCRIPTION	QTY	ITEM	DESCRIPTION	QTY
1	PAN/TANK	1	30	FAN CENTRIFUGAL	1
2	LID	1	31	SHAFT (FAN)	1
3	PANEL FRONT	1	32	BEARING	2
4	PAD FRAME	3	33	MOUNT RESILIENT BEARING	2
5	PAD ASSEMBLY	3	34	MOUNT BEARING (NON DRIVE END)	1
6	WIRE ASSEMBLY	3	35	MOUNT BEARING (DRIVE END)	1
7	POST CORNER	4	36	LOCK BEARING (NON DRIVE END)	1
8	SCROLL L/H (MOTOR)	1	37	LOCK BEARING (DRIVE END)	1
9	SCROLL R/H	1	38	PULLEY FAN (205 or 225)	1
10	PLATE CUTOFF	1	39	PULLEY MOTOR ADJUSTABLE	1
13	BAFFLE	2	40	PIN BLACK PLASTIC	3
15	SEALING TAPE		42	V-BELT	1
17	PLATE MOTOR MOUNT	1	43	SPREADER	3
18	BOLT CUP HEAD	4	44	4 WAY DISTRIBUTOR	1
19	WASHER M10 x 21 x 1.6ZP	2	45	PVC TUBE 3/4" (ID)	
20	NUT WHIZ M8ZN	8	46	PVC TUBE 1/2" (ID)	
21	BRACKET MOTOR MOUNT ADJUSTING	2	47	FIRE DETECTOR (if used)	1
22	BOLT	2	48	BOTTLE (RESERVOIR)	1
23	BOOT	2	49	SPRINKLER AND TEE-PIECE ASSY	1
24	RIVETS & WASHERS (FOR PLATE MOTOR MOUNT, NOT ILLUSTRATED)		50	FLOAT VALVE ASSEMBLY	1
25	PLUG HOLE TRANSITION		51	NUT	1
27	PUMP MOTOR	1	52	GRILLE	1
28	MOTOR	1	53	GRILLE MOUNT	1
29	JUNCTION/TERMINAL BOX	1	54	CASTOR (LOCKING)	2
			55	SCREW M8 x 75 (NOT ILLUSTRATED)	
			56	CASTOR WHEELS	2

This is a list of some common service problems, with probable causes and suggested remedies.

PROBLEM	PROBABLE CAUSE	SUGGESTED REMEDY
Inadequate cooling	<i>Insufficient fresh air.</i>	<i>Ensure cooler is located adjacent to a door or adequate fresh air supply.</i>
	<i>Insufficient air discharge openings or inadequate exhaust from area being cooled, causing high humidity and discomfort.</i>	<i>Make sure there is adequate provision for exhausting air from area being cooled (open windows and/or doors).</i>
	<i>Undersized cooler.</i>	<i>Replace with larger cooler or additional coolers.</i>
	<i>Clogged or dirty filter pads.</i>	<i>Clean or replace pads.</i>
	<i>Dry pads or lack of water while cooler is in operation.</i>	<i>Check water distribution system for possible obstruction in tubing. Check Pump.</i>
	<i>Excessive Ambient Humidity (see also item above re: inadequate exhaust).</i>	<i>On days during the summer when the ambient humidity is high, the cooler will not reduce temperature as much as on drier days. There is no remedy except to shut off the pump.</i>
	<i>Fan turning backwards.</i>	<i>Reconnect motor for correct rotation.</i>
	<i>Fan running too slow.</i>	<i>Check motor amps. If below name plate amperage, re-adjust motor (sheave) pulley to increase fan speed.</i>
	<i>Belt slipping.</i>	<i>Tighten belt by re-adjusting position of motor. Replace belt if worn.</i>
	<i>Faulty water pump.</i> <i>NOTE: This cooler is equipped with an electronic safety system which continuously monitors the condition of the water pump. This safety system will automatically turn the isolating switch to OFF position when a water pump defect is detected.</i>	<i>Replace the water pump and reset the isolating switch to ON position.</i>

This is a list of some common service problems, with probable causes and suggested remedies.

PROBLEM	PROBABLE CAUSE	SUGGESTED REMEDY
Fan fails to start (cont.)	<i>Circuit breaker tripped or fuse blown.</i>	<i>Reset circuit breaker or replace fuse. See procedure Section 1 - Safety.</i>
	<i>Loose electrical connections.</i>	<i>Check all electrical connections.</i>
	<i>Defective control switch.</i>	<i>Replace.</i>
	<i>Motor burned out.</i>	<i>Replace.</i>
	<i>Belt or pulley loose.</i>	<i>Tighten belt and pulleys.</i>
	<i>Belt broken or missing.</i>	<i>Install new belt.</i>
	<i>Belts too tight.</i>	<i>Adjust belt tension.</i>
	<i>Wrong setting of adjustable motor pulley (sheave) causing motor overload.</i>	<i>Adjust pulley (sheave) so motor amperes do not exceed full load amperes shown on motor nameplate (see earlier instruction in this manual).</i>
	<i>Low system voltage.</i>	<i>Consult with Electrical Authority if voltage is low.</i>
Belt Slipping or wearing excessively	<i>Incorrect motor, motor has been changed and wrong size fitted.</i>	<i>Fit correct size motor.</i>
	<i>Belt loose.</i>	<i>Tighten belt.</i>
	<i>Pulleys out of line.</i>	<i>Align pulleys.</i>
	<i>Moisture getting on belt.</i>	<i>Stop any water leaks.</i>
	<i>Worn belts.</i>	<i>Replace belts.</i>
	<i>Worn or imperfect pulleys.</i>	<i>Replace pulleys.</i>
	Pump fails to operate	<i>Pump motor failure.</i>
<i>Incorrect wiring of pump motor and control switch.</i>		<i>Correct wrong electrical connection.</i>
<i>Loose electrical connections.</i>		<i>Tighten electrical connections.</i>
<i>Pump control switch faulty.</i>		<i>Replace pump control switch.</i>

This is a list of some common service problems, with probable causes and suggested remedies.

PROBLEM	PROBABLE CAUSE	SUGGESTED REMEDY
Pump fails to operate (cont.)	<i>Insufficient water in pan/tank.</i>	<i>Refill water tank.</i>
	<i>Pump strainer blocked.</i>	<i>Clean strainer.</i>
	<i>Blocked water tubing.</i>	<i>Clean the tubing.</i>
	<i>Foreign material lodged in the "water spreader/s".</i>	<i>Remove spreader/s and clean out foreign material.</i>
Noisy Air Cooler	<i>Fan out of balance due to dirt, etc.</i>	<i>Clean fan.</i>
	<i>Cooler delivering more air than needed.</i>	<i>Adjust motor pulley (sheave) to slow down fan.</i>
	<i>Belt "squealing".</i>	<i>Tighten belt by adjusting motor. Apply belt dressing to belt. In some cases it may be necessary to replace belt or pulley.</i>
Water being thrown into room	<i>Loose water tubing connections.</i>	<i>Tighten all connections.</i>
	<i>Break in water tubing.</i>	<i>Replace any cracked or broken tubing.</i>
	<i>Pads not properly installed in pad frames.</i>	<i>Make sure pads are properly installed.</i>
	<i>Incorrect or damaged pads fitted.</i>	<i>Replace with the manufacturer's recommended pads.</i>
Overflow of water	<i>Float valve not sealing properly.</i>	<i>Clean or replace valve washer.</i>
Unpleasant Odour	<i>New cooler pads.</i>	<i>Run pump continuously for a while to flush the pads.</i>
	<i>Cooler located near source of unpleasant odor.</i>	<i>Remove source of odor or place a barrier between cooler and source of odor.</i>
	<i>Algae in pan/tank water.</i>	<i>Drain pan/tank and clean thoroughly. Fill with fresh water. Install new pads.</i>
	<i>Pads remain wet after shut down.</i>	<i>Allow fan to run for about ten (10) minutes after pump is shut off to dry out pads.</i>
Rapid formation of white deposits on Pads and Louvres	<i>High mineral content of supply water.</i>	<i>Drain water from tank more regularly and refill with fresh water.</i>

Appendix 1-AUTHORIZED FAN MOTORS & WATER PUMPS

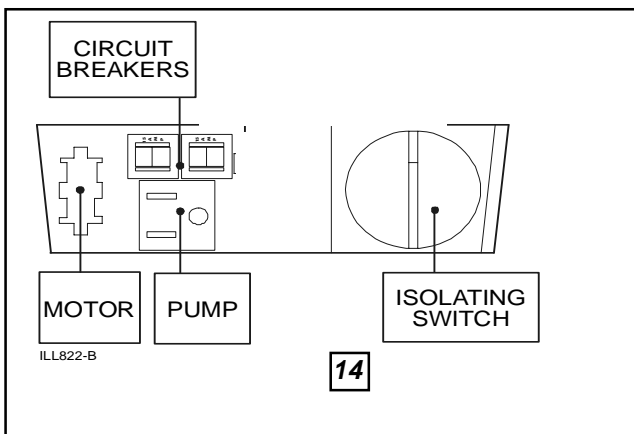
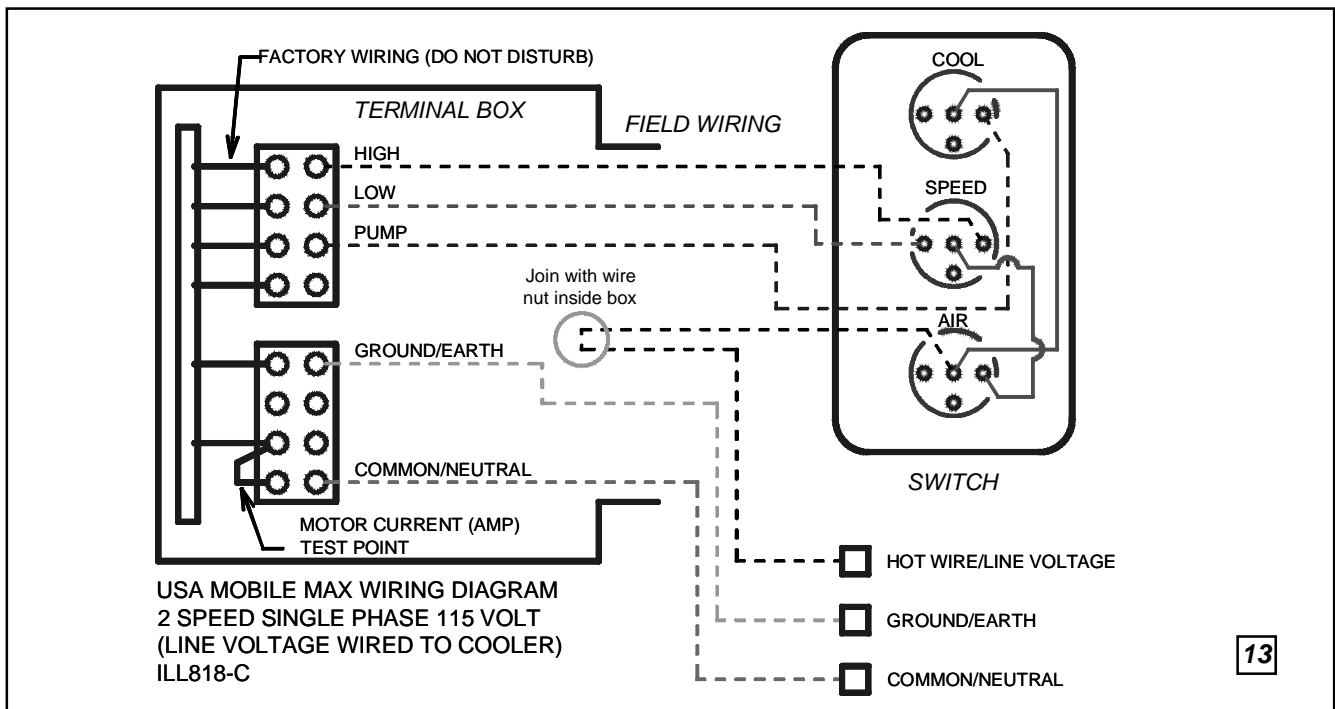

Factory Authorized Fan Motors

- Seeley Selectric 2 speed motors: 3/4 HP - 2 speed part # : 095455 (Mobile Max II)
1 HP - 2 speed part # : 095448 (Mobile Max III)
- Dial : 1 HP - 2 speed copper wound cooler motors part # : 2390

Factory Authorized Water Pumps

- Seeley Tornado Pump :115V/60 Thermally protected pump : part # : 095851 (on floating deck)

"Power Clean" Style Timed Pumps

Under no circumstances are "Power Clean" style timed pumps to be used in any Convair cooler.
Use of these or other similar devices will cause serious damage to the special safety circuits of this cooler.

Failure to follow this instruction will void all warranty and may cause severe risk of electric shock and fire!



Appendix 2 - CHECK LIST

Owners Name: _____

Telephone: _____

Address: _____

Dealer: _____

Installer: _____

Date Installed: _____

Model No.: _____

Serial No.: _____

Motor Type: _____

Motor H.P.: _____



1202 N 54th Ave
 Building 2 Suite 117
 PHOENIX AZ 85043
 Phone: 1-602-353 8066
 Fax: 1-602-353 8070

SERVICE ENQUIRIES:

Contact your local Retailer.

As the policy of the Company is one of continuous product improvement,

DO NOT OPERATE COOLER UNTIL THE CHECKLIST BELOW HAS BEEN SATISFACTORILY COMPLETED

- Belt tension and alignment correctly adjusted.
- Fan runs in correct direction at all speeds (clockwise when viewed from pulley side).
- Motor amps tested at high speed with vents and windows open.
- Amps input to motor recorded High _____ amps
Low _____ amps
- Motor and pump are properly plugged into sockets.
- Fire protection system plugged in.
- Motor pulley adjusted and tight on shaft.
- Drain fitting correctly installed.
- Water level and float adjustment checked.
- Pump runs and water evenly distributed to all filter pads.
- All control functions checked.
- Owner instructed in correct operating procedure and supplied with operating instructions.