

This Owner's Manual is provided and hosted by [Appliance Factory Parts](http://ApplianceFactoryParts.com).

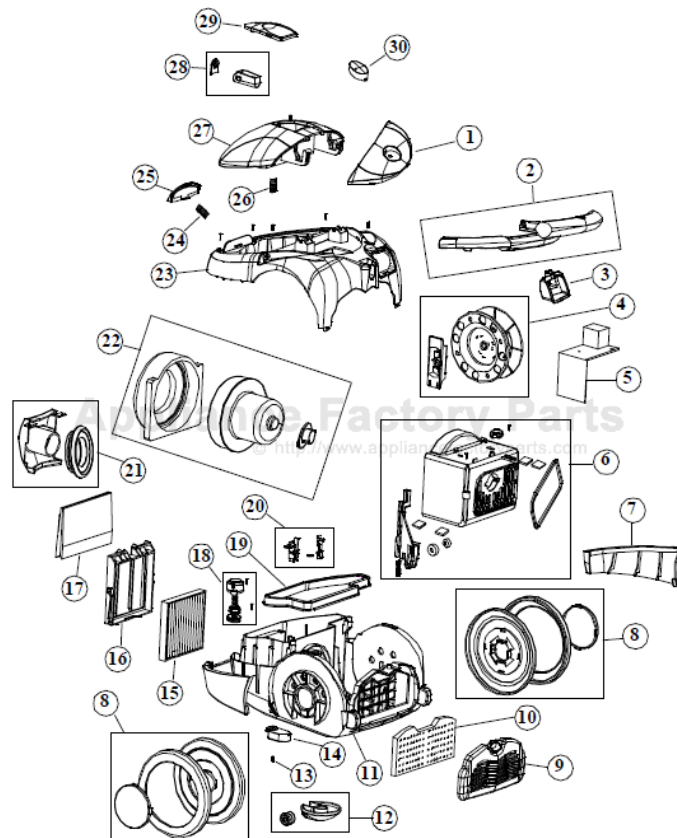

# FULLER BRUSH FBCC-1 Owner's Manual

[Shop genuine replacement parts for FULLER BRUSH  
FBCC-1](#)



[Find Your FULLER BRUSH Vacuum Cleaner Parts - Select From 23 Models](#)

----- Manual continues below -----

# FULLER BRUSH

# FBCC-1 Model

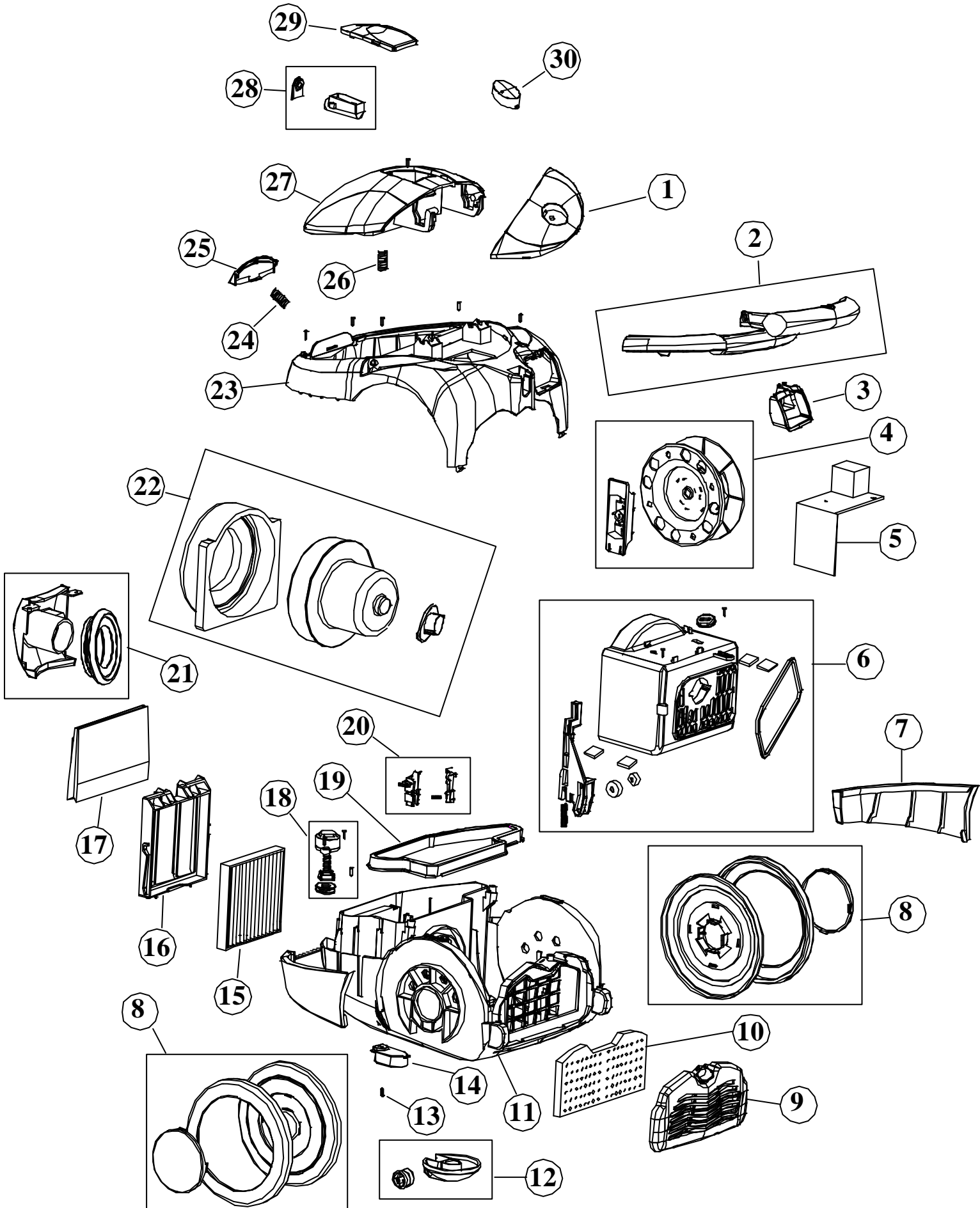

<b>KEY</b>	<b>PART NO</b>	<b>DESCRIPTION</b>
1	84.084	Rear Cover
2	84.085	Handle and Cove Assy
3	84.086	Cord Outlet Seat
4	84.087	Cord Rewinder
5	84.088	PCB Board
6	84.089	Cord Rewind Button Assy
7	84.090	Crashworthy Block
8	84.091	Rear Big Wheel Assy
9	84.092	Rear Filter
10	84.093	Air Outlet Board
11	84.094	Lower Body
12	84.095	Front Wheel Assy
13	84.096	Screw for Dock Block
14	84.097	Wand Bracket Block
15	84.098	Filter
16	84.099	Air Inlte Grille
17	FBC-6	Dustbag
18	84.100	Vacuum Protective Valve
19	84.101	Seat Circle
20	84.102	Dustbag Protective Staff & Knob Assy
21	84.103	Suction Seat
22	20.852	Motor Assembly
23	84.104	Middle Cover
24	84.105	Spring of Buckle
25	84.106	Clamp
26	84.107	Spring of Handle
27	84.108	Front Cover
28	84.109	Indicater & Seal Assy
29	84.110	Decorate Block on Front Cover
30	84.111	Cover Board
Not Shown	26.800	Telescopic Metal Tube
Not Shown	19.545	Handgrip Hose
Not Shown	05.700	Brush
Not Shown	05.701	Tool Caddy