

This Owner's Manual is provided and hosted by [Appliance Factory Parts](#).



Fantom FM718 Owner's Manual

[Shop genuine replacement parts for Fantom FM718](#)



[Find Your Fantom Vacuum Cleaner Parts - Select From 37 Models](#)

----- Manual continues below -----



CYCLONIC BAGLESS

OWNER'S MANUAL
Model FM718
120V., 60Hz., 12 Amps



FA
94 Main Mill
Plattsburg
Tel.: 1 (8
www.f

ONE (1) YEAR LIMITED WARRANTY

FANTOM warrants this product to be free of defects in materials and workmanship for a period of one (1) year from the date of purchase. This warranty applies only to normal domestic use. It does not cover an appliance that fails to operate properly while in normal use under normal conditions within the one (1) year warranty period. Labor, parts, appliance and accessories, freight preparation and return shipping are excluded.

FANTOM 94 Main Mill Street, Door 16, Shenzhen, China

Should the appliance is found to be defective within the warranty period, **FANTOM** will repair or replace it free of charge. A \$16.95 shipping fee will be charged to cover the cost of return shipping. Non-durable parts including, without limitation, light bulbs and electrical parts which normally excluded from warranty.

The liability of **FANTOM** is limited solely to the repair or replacement of the unit at our option. This warranty does not cover units that have been used for commercial purposes. This limited warranty does not cover damage caused by abuse, negligent handling or damage during transit. This warranty does not cover damages from shipping or repairs, or any of its parts, which have been performed by others other than **FANTOM**.

This warranty is extended to the original purchaser. Any other legal and/or conventional warranties, in whole or in part, if any, is limited to the specific obligations set forth in the terms of the limited warranty. **In no event** shall **FANTOM** be liable for consequential damages of any nature whatsoever. The exclusion or limitation of incidental or consequential damages may not apply to you.

This warranty gives you specific legal rights which vary from state to state.

***Important: Carefully pack item to avoid damage. Please include proof of purchase date and to include your name, complete address and phone number with purchase information, model number and serial number with item. We recommend you insure your purchase. Damage is not covered by your warranty). Mark the box with "ATTENTION CUSTOMER SERVICE". We strive to improve our products, therefore the specifications are subject to change without notice.**

IMPORTANT SAFETY

When using your *Bagless Upright Vacuum*, the following safety instructions must always be observed, including the following:

WARNING: To reduce the risk of fire, electrical shock, or injury:

1. Do **NOT** leave vacuum cleaner unattended when it is plugged in. Unplug from outlet when not in use and before removing filters.
2. To reduce the risk of electric shock – do **NOT** use outdoors or on wet surfaces.
3. Do **NOT** allow children to use as a toy. Close attention is necessary when used by or near children.
4. Use only as described in this manual. Use only manufacturer's recommended attachments.
5. Do **NOT** use with damaged cord or plug. Do **NOT** use vacuum cleaner if it has been dropped, damaged, left outdoors, or dropped into water. Return appliance to **FANTOM** for examination, repair or adjustment.
6. Do **NOT** pull or carry by cord. Do **NOT** use cord as a handle, close a door on cord, or pull cord around sharp edges or corners. Do **NOT** run appliance over cord. Keep cord away from heated surfaces.
7. Do **NOT** unplug by pulling on cord. To unplug, grasp the plug, not the cord.
8. Do **NOT** handle plug or vacuum cleaner with wet hands.
9. Do **NOT** use the vacuum cleaner to pick up large objects or objects that are likely to damage the vacuum cleaner.
10. Keep hair, loose clothing, fingers, feet and all parts of body away from openings, rotating agitator and other moving parts. Do **NOT** operate cleaner in bare feet or when wearing open toe shoes.
11. Do **NOT** pick up hot coals, cigarette butts, matches or any hot, smoking, or burning objects.
12. Do **NOT** pick up hard or sharp objects such as glass, nails, screws, coins, etc.

SAVE THESE INSTRUCTIONS

For Household Use

WARNING: To reduce the risk of fire, electrical shock, or injury, use only a three-prong polarized plug (one blade is wider than the other) and insert into a properly polarized outlet only one way. If the plug does not fit, reverse the plug. If it still does not fit, contact a qualified electrician to install the proper outlet. Do **NOT** modify the plug.

PRECAUTIONARY MEASURES

Important: If the suction opening in the unit, the hose or the extension tube become blocked, switch off the vacuum cleaner and remove the blocking substance before you start the unit again.

1. Do not operate the vacuum cleaner to close too heaters, or radiators.



2. Before inserting the power plug into the wall outlet, make sure that your hands are dry.

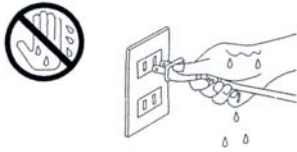

3. Do not vacuum any liquids.



4. Keep hair, loose clothing, fingers, feet and all parts of body away from openings, rotating agitator and other moving parts.

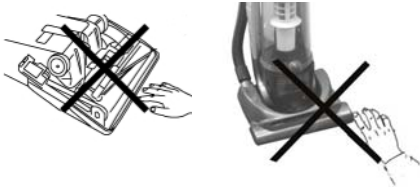

5. When pulling out the power plug from the wall outlet, pull the plug not the power cord.

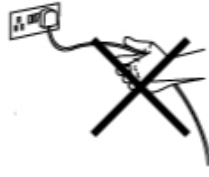

6. Do not pick up anything that is burning or smoking such as cigarettes, matches or hot ashes.

7. Do not run appliance over power cord.



8. Do not use without dust cup filter or filters in place.

9. Before you start vacuuming, make sure to remove large or sharp objects that might damage the vacuum.



Fan

CYCLONIC BAG

**TO ORDER REPLACEMENT
OR FOR TECHNICAL ASSISTANCE
for Model**

Call: 1 (800) 2...
Monday to Friday 8:30 A.M. - 5:00 P.M.
or
visit our website: www...

Please Read

Filter Ring, Pre-Motor, Secondary and Bag Filter should however be replaced every three months to ensure peak performance of your vacuum. The HEPA Dust Cup Filter may be washed and replaced every three (3) to six (6) months. To ensure peak performance of your vacuum, wash the HEPA Dust Cup Filter, hold filter cartridge by filter ring until all observable dirt has been removed. HEPA filter material may occur, this is normal. When finished, shake off dirt in a dishwasher. It is important that when you wash the HEPA filter, pre-motor filter or the bag filter, you wash them **COMPLETELY** before using again. **DO NOT DRY IN DRYER.**

Important

Make sure that ALL washable Filters are placed back in the vacuum.

PROBLEM SOLVING

This appliance was inspected thoroughly and was in good operating condition when it was shipped from the factory. If a minor problem occurs, it usually can be solved quite easily when the cause is found. Therefore, this checklist is provided for your convenience.

PROBLEM	POSSIBLE CAUSE	POSSIBLE
Cleaner Won't Run	<ol style="list-style-type: none"> 1. Not properly plugged into wall outlet. 2. No electricity in wall outlet. 3. On/Off switch not turned on. 4. Motor thermostat tripped. 5. Blown fuse/tripped breaker. 	<ol style="list-style-type: none"> 1. Plug in firmly. 2. Check fuse or breaker. 3. Push on/off switch to on 4. Reset motor thermostat. (page 8) 5. Reset circuit breaker or replace fuse.
Cleaner Won't Pick Up	<ol style="list-style-type: none"> 1. Full or clogged dust cup. 2. Wrong pile height setting. 3. Clogged nozzle. 4. Clogged dust inlet port. 5. Clogged hose. 6. Broken belt. 7. Hose not inserted fully. 8. Dirty filters. 9. HEPA filter needs cleaning or replacing. 10. HEPA filter frame needs cleaning. 	<ol style="list-style-type: none"> 1. Clean dust cup. (page 5) 2. Adjust setting. (page 5) 3. Remove obstruction. 4. Remove power head cover and remove obstruction. 5. Remove obstruction. 6. Replace belt. (page 8) 7. Push hose in securely. 8. Clean / change filters. (page 7) 9. Clean or replace HEPA filter. (page 6) 10. Clean HEPA filter frame. (page 6)
Cleaner Picks Up Moveable Rugs Or Pushes Too Hard	<ol style="list-style-type: none"> 1. Wrong pile height setting. 	<ol style="list-style-type: none"> 1. Adjust setting. (page 5)
Agitator Does Not Turn	<ol style="list-style-type: none"> 1. Broken belt. 2. Belt installed incorrectly. 	<ol style="list-style-type: none"> 1. Replace belt. (page 8) 2. Check belt changing and agitator cleaning. (page 8)
Air Flow Restricted With Attachment Use Sound Changes	<ol style="list-style-type: none"> 1. Attachment use restricts air flow. 2. New carpet debris clogging air path. 	<ol style="list-style-type: none"> 1. Check attachment. (page 4) 2. Remove obstruction.

GETTING TO KNOW YOUR UPRIGHT

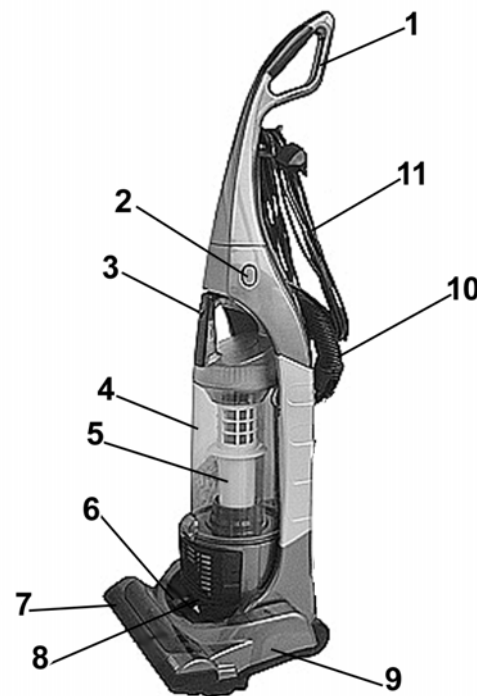

- 1. Upper Handle
- 2. On/Off Switch
- 3. Dust Cup Release Button
- 4. Dust Cup
- 5. HEPA Filter Frame
- 6. Carpet Height Selector
- 7. Furniture Guard
- 8. Head Light
- 9. Motorized Power Head

Technical Specifications

Voltage: 120V., 60Hz.
Power: 12 Amps

Note: Illustrations may differ from actual product.

Assembling Your Vacuum Cleaner

Note: Do not plug the power cord into an electrical outlet until the vacuum is fully assembled.

Handle Assembly

- Carefully unpack all components, set aside packaging.
- Lift vacuum body to upright position.
- Remove the screw (1) that comes attached to the body.
- From the rear of the vacuum, align the handle with groove and slide onto vacuum. If necessary, use thumb and finger pressure to slide handle into position.
- Once handle is in place, secure the handle with the screws (2). (Fig. 1)

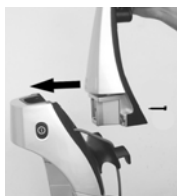

Fig. 1

Caution: Do not over tighten. Over tightening could strip the screw holes. Do not operate the vacuum without the handle screws in place.

Cord Assembly

- Make sure that the quick release cord holder is in the upright position.
- Remove the wire tie from the power cord.
- Wrap the cord into place by wrapping it in a clockwise direction around the quick release cord holder and the lower cord holders. (Fig. 2)
- Turn the quick release cord holder to the left or to the right to unwrap the power cord. (Fig. 2)

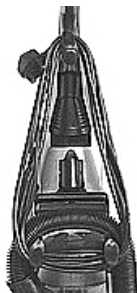

Fig. 2

Warning: Always make sure that the vacuum is turned off before unplugging.

Using the Attachments

- Place vacuum in its upright position. Make sure that the vacuum cleaner is **NOT** plugged into the electrical outlet when adding or removing accessories.
- Turn the carpet height selector to the highest position and set the Carpet to Floor selector to the "Floor" position.**
- Remove the hose connector from the rear of the unit and push in the desired attachment firmly onto the end of the hose.
- If additional length is required, attach the extension tubes to the end of the hose and then attach the crevice tool, round brush or upholstery brush to the end of the extension tube.

Warning: Avoid tipping the vacuum or setting it on furniture, fringed area rugs or carpeted stairs while you are using the hose with the attachments. When using the unit to vacuum floors or with attachments, set the Carpet to Floor Selector to the "Floor" position. This will stop the beater brush from rotating. When vacuuming carpets, avoid leaving the vacuum in one place for an extended period of time, particularly on thick carpet.

Caution: Do **NOT** pull the vacuum cleaner around the room by the hose as it could tip over and cause damage. When using the attachments, do **NOT** over extend the hose length when reaching. Trying to reach beyond the hose reach could cause the vacuum to tip over.

How to Start

The upright vacuum can be used on multiple types of carpeting, bare floors or upholstery with attachments. When using the attachment tools such as the crevice tool, round brush or the upholstery brush, place the handle of the vacuum in the upright position.

- Turn the quick release cord holder to either side 180° to release the power cord.
- Plug the power cord into the electrical outlet.
- Push the On/Off button to the "On" position to turn the vacuum on.
- To release the handle, step on the power head and pull the handle back.
- When using the attachments, the vacuum must be in the upright position. (Fig. 3)

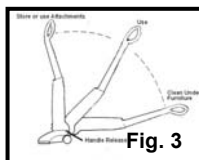

Fig. 3

- Remove the belt cover (Fig. 22, #1)
- Lift the right side of the brush bar first and then lift the left hand side. (Fig. 22 #2, #3)
- Remove the brush bar from the power head. (Fig. 22, #4)
- Carefully remove any belt residue that may exist in the belt area before replacing with a new belt.
- Remove the worn or broken belt from the motor drive shaft.
- Loop the new belt first over the motor drive shaft and then over the agitator pulley.

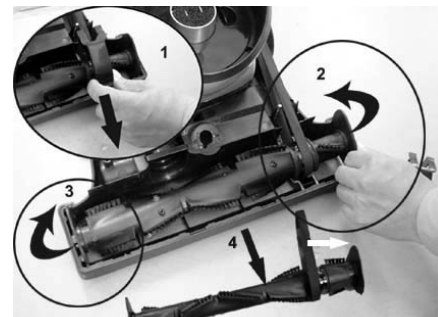

Fig. 22

- Insert the right side of the brush bar in first by placing the end cap down into the slot and then do the same with the left side. Press firmly to make sure that each end is completely inserted.
- Check to make sure that the belt is centered on the agitator pulley and that the brush bar turns.
- Replace the belt cover.
- Replace the power head cover and turn the unit over carefully.
- Replace the lower plate, screwing in the four (4) outer screws first.
- When screwing in the center screw, hold the carpet height adjustment knob from the outside and screw in the last screw.
- Replace the lower plate.
- Once the lower plate is attached, replace the base plate with the four (4) screws.

Cleaning the Dust Cup

Warning: To reduce the risk of electric shock, the power cord must be disconnected before removing the dust cup, HEPA filter, changing the filters or performing maintenance/trouble shooting checks.

The dust cup can be washed in lukewarm water. Do not use strong detergents. Ensure that the dust cup is fully dry before putting back on the vacuum cleaner. (Fig. 18) Do not wash in dishwasher.



Fig. 18

Motor Thermostat

Important: This unit is equipped with a motor protective thermostat. If for some reason the vacuum cleaner should overheat, the thermostat will automatically turn the unit off. Should this occur:

- Push the On/Off button once.
- Disconnect the plug from the power source.
- Check the source of overheating problem. (i.e. clogged hose or filter)
- If clogged hose or filter is found, unclog the hose and replace the filters.
- Wait at least 45 minutes before attempting to reuse the vacuum.
- After unit has cooled down for 45 minutes, plug in the cleaner and push the On/Off button. The vacuum should start again.
- If the vacuum still does not start, contact **FANTOM** customer service at 1 (800) 275-9251.

Cleaning & Changing the Belt

Warning: To reduce the risk of electric shock, the power cord must be disconnected before removing the dust cup, HEPA filter, changing the filters or performing maintenance/trouble shooting checks.

Occasionally the power nozzle drive belt will require changing, the frequency will depend upon the amount of use your vacuum sees.

1. Turn the vacuum "Off" and unplug from power supply.
2. Turn the vacuum upside down on a flat level surface.
3. Using a Philips screw driver, remove the four (4) screws that attach the base plate to the lower plate. (Fig. 19)



Fig. 19

4. After you have removed the base plate, remove the remaining five (5) screws from the lower plate using a Philips screw driver. (Fig. 20)

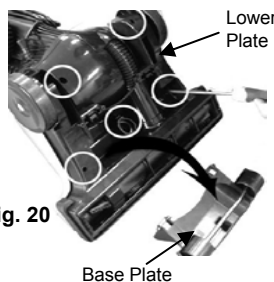

Fig. 20

5. With the unit still lying down, turn the unit over and lift the power head cover starting from the back of the power head. (Fig. 21)



Fig. 21

Carpet Height Selector

This upright vacuum can be used on multiple types of carpeting, bare floors or upholstery with attachments.

To select a pile height setting:

1. Turn vacuum cleaner "Off".
2. Select a pile height setting by sliding the carpet height selector to the desired setting. (Fig. 4)

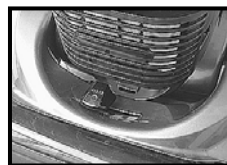
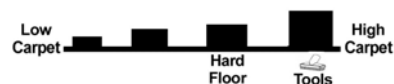

Fig. 4

Suggested Pile Height Setting: You may need to raise the height of the vacuum to make some jobs easier, such as scatter rugs and longer pile carpets. Suggested settings are:



- HIGH:** shag carpet, long pile, plush scatter rugs, tools
- MED:** medium to long pile
- LOW:** short to medium pile, bare floors
- FLOOR:** very low pile, bare floors

Place unit in "HIGH" setting when using attachments to prevent possible floor damage. Always set the Carpet to Floor selector to "Floor" setting when using the accessories. (Fig. 5)

Attention: Special care is required when vacuuming certain types of carpet or floor covering. Always check the carpet or floor covering manufacturer's recommended cleaning instructions before vacuuming.



Fig. 5

Cleaning the HEPA Dust Cup Filter

IMPORTANT, Please Note : The Rinseable "TapClean" HEPA Dust Cup Filter will stop most of the tiniest dust particles and airborne allergens from re-entering the air you breathe. In fact, it stops 99.97% of all particles as small as 0.3 microns - many times smaller than a human hair!!! Because of this incredible filtration performance, the HEPA Dust Cup Filter will quickly accumulate many fine dust particles inside the white filter folds that are difficult to see but which will eventually block or reduce your suction power - if not cleaned properly. Clean the HEPA Filter after each use as described in this section.

1. To remove the HEPA filter, remove the dust cup from the unit.
2. To remove the dust cup cover, hold the cover by the handle, turn counter clockwise and lift the cover off. (Fig. 9)
3. Remove the HEPA Rinseable "Tap Clean" filter from the dust cup. (Fig. 10)



Fig. 9

4. Remove the filter ring that is around the HEPA filter. Vigorously "TapClean" the HEPA dust cup filter on a hard surface until no more dust is observed falling out. (Fig. 11) The HEPA filter may also be washed by running it under the tap allowing the water to run on the dirty side. (Fig. 12) We recommend washing it once a month or when suction appears reduced. Always allow 24 hours for air drying before replacing into the vacuum.



Fig. 10



Fig. 11



Fig. 12

Please Note: The white material in the HEPA filter will discolor over time - This is NORMAL and will NOT affect the performance of the filter.

Warning: Always empty the dust cup and clean the HEPA dust cup filter before each use and during prolonged usage. Never over fill the dust cup - remove dirt and clean the HEPA dust cup filter each time the dust cup is emptied during prolonged usage or risk motor damage.

Cleaning the HEPA Filter Frame

1. Before replacing the HEPA filter in the HEPA Filter frame, you can (should) rinse the frame in lukewarm water by just running it under the tap to remove any dust that is adhering to the frame. (Fig. 13) Do NOT place in dishwasher.

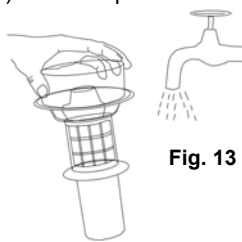

Fig. 13

2. Make sure that the filter frame is completely dry before replacing into the dust cup. Always air dry.

Cleaning the Filter Ring

1. Around the HEPA filter there is a filter ring. This is washable in lukewarm water. (Fig. 14) To remove the filter ring, slide it off the HEPA filter.
2. We recommend washing the filter ring when you are washing your HEPA filter. Always allow the filter ring to air dry for 24 hours before replacing onto the HEPA filter. Never run the vacuum without all the filters in place.

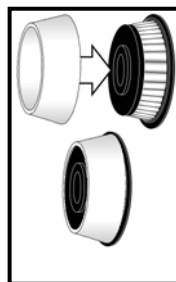

Fig. 14

Note: This is a washable filter, but we recommend replacing it every three (3) months.

Cleaning the Secondary Filter

1. Underneath the HEPA filter there is a secondary filter. This is washable in lukewarm water. (Fig. 15) We recommend washing it when you are washing your HEPA filter. Always allow the secondary filter to air dry for 24 hours before replacing into the vacuum. Never run the vacuum without the secondary filter in place. Fig. 15



Changing & Cleaning the Pre-Motor Filter

Warning: To reduce the risk of electric shock, the power cord must be disconnected before removing the dust cup, HEPA filter, changing the filters or performing maintenance/trouble shooting checks.

The pre-motor filter is located in the vacuum underneath the dust cup. Please note that this filter is a washable filter and can be cleaned by rinsing under lukewarm water. Always allow the pre-motor filter to air dry for 24 hours before replacing in the vacuum. Do not use a hair dryer to dry it. Air dry only. To remove the pre-motor filter:

1. Remove the dust cup. (See instructions on page 5 for removing the dust cup).
2. Hold the Pre-Motor filter cover and turn counter-clockwise to unlock and lift to remove. (Fig. 16)
3. Remove the pre-motor filter and clean by rinsing under lukewarm water.
4. After air drying for 24 hours, replace in the vacuum.
5. To replace the pre-motor filter cover, insert the locking lugs into the lug holes and turn clockwise to lock.