

This Owner's Manual is provided and hosted by [Appliance Factory Parts](http://ApplianceFactoryParts.com).

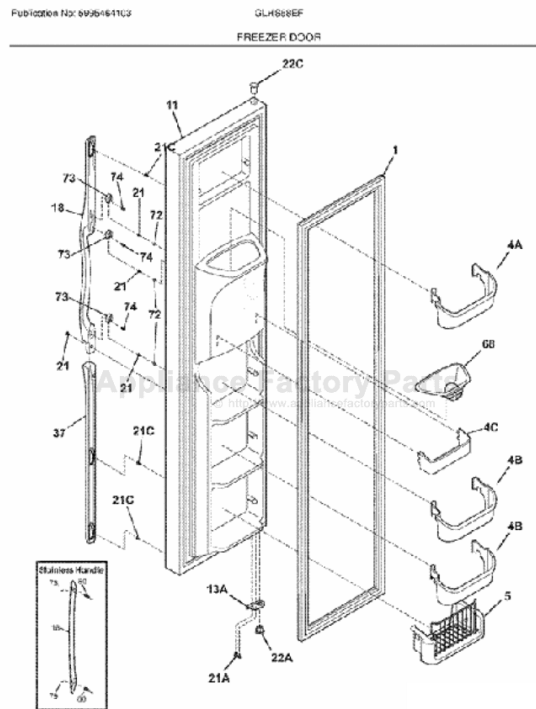

FRIGIDAIRE GLHS68EFB1 Owner's Manual

[Shop genuine replacement parts for FRIGIDAIRE
GLHS68EFB1](#)



[Find Your FRIGIDAIRE Refrigerator Parts - Select From 5957 Models](#)

----- Manual continues below -----

Use & Care Manual







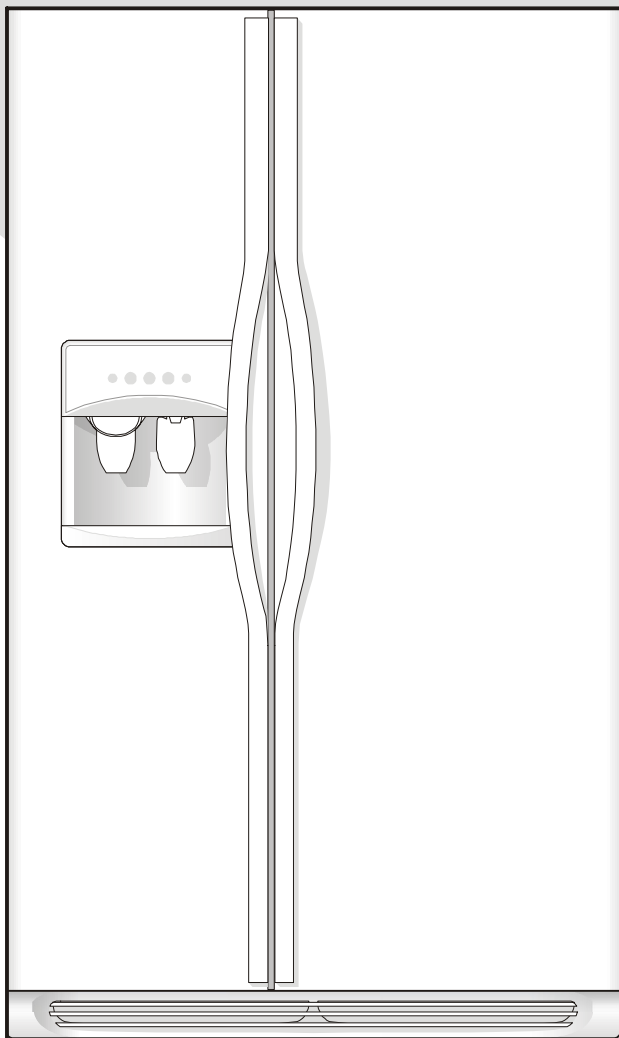



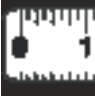

Side by Side

Refrigerator

With Electronic Controls



Español 27

Welcome	2	
Safety Instructions	3	
Installation -- Includes Connecting Ice Maker To Water Supply.....	4 - 5	
Door Removal Instructions	6	
Features at a Glance	7	
Temperature Controls	7 - 9	
Looking Inside	10 - 11	
Automatic Ice and Water Dispenser	12 - 17	
Food Storage & Energy Saving Tips	18	
Normal Operating Sounds ..	19	
Care & Cleaning	20 - 21	
Warranty	22	
Before You Call Solutions to Common Problems.....	23 - 26	

READ AND SAVE THESE INSTRUCTIONS

P/N 241695101 (0106)



WELCOME & CONGRATULATIONS

Congratulations on your purchase of a new refrigerator! We here at **Electrolux Home Products, Inc.** are very proud of our product and we are completely committed to providing you with the best service possible. Your satisfaction is our #1 priority.

Please read this Use & Care Manual very carefully. It contains valuable information on how to properly maintain your new refrigerator.

We know you'll enjoy your new refrigerator and **Thank You** for choosing our product. We hope you consider us for future purchases.

PLEASE READ AND SAVE THESE INSTRUCTIONS

This Use & Care Manual provides specific operating instructions for your model. Use your refrigerator only as instructed in this manual. These instructions are not meant to cover every possible condition and situation that may occur. Common sense and caution must be practiced when installing, operating and maintaining any appliance.

Please record your model and serial numbers below for future reference. This information is found on the serial plate located inside the refrigerator compartment.

NOTE

Use only soap and water to clean serial plate.

Model Number: _____

Serial Number: _____

Purchase Date: _____

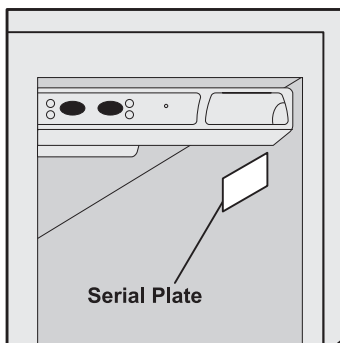

Serial Plate

Please attach sales receipt here for future reference.

Questions?

1-800-944-9044

(United States)

1-800-265-8352

(Canada)

or visit our web site at www.frigidaire.com

Extend Your Warranty Protection With An *Extended Service Contract*

CALL 1-800-944-9044

To Enjoy These Benefits:

- **Total freedom from repair bills** so unexpected repairs won't upset your budget.
- **Fast, convenient toll-free service** is just a phone call away.
- **Top-quality repairs** by factory-trained experts.
- **Quick access to genuine replacement parts** so you can rest assured your refrigerator is repaired with the proper components.

PLEASE COMPLETE AND MAIL IN THE PRODUCT REGISTRATION CARD INCLUDED WITH YOUR REFRIGERATOR.



IMPORTANT SAFETY INSTRUCTIONS



WARNING

Please Read All Instructions Before Using This Refrigerator.

FOR YOUR SAFETY

- Do not store or use gasoline, or other flammable liquids in the vicinity of this or any other appliance. Read product labels for warnings regarding flammability and other hazards.
- Do not operate the refrigerator in the presence of explosive fumes.
- Avoid contact with any moving parts of automatic ice maker.
- Remove all staples from the carton. Staples can cause severe cuts, and also destroy finishes if they come in contact with other appliances or furniture.

CHILD SAFETY

Destroy or recycle the carton, plastic bags, and any exterior wrapping material immediately after the refrigerator is unpacked. Children should **NEVER** use these items to play. Cartons covered with rugs, bedspreads, plastic sheets or stretch wrap may become airtight chambers, and can quickly cause suffocation.

PROPER DISPOSAL OF YOUR REFRIGERATOR OR FREEZER

Risk of child entrapment

Child entrapment and suffocation are not problems of the past. Junked or abandoned refrigerators or freezers are still dangerous – even if they will sit for “just a few days.” If you are getting rid of your old refrigerator or freezer, please follow the instructions below to help prevent accidents.

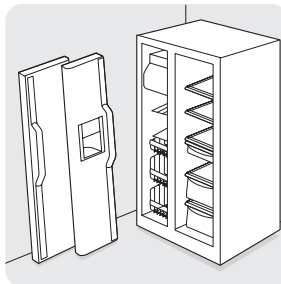

Before you throw away your old refrigerator/ freezer:

- Remove doors.
- Leave shelves in place so children may not easily climb inside.
- Have refrigerant removed by a qualified service technician.



WARNING

These Guidelines Must Be Followed To Ensure That Safety Mechanisms In This Refrigerator Will Operate Properly.

ELECTRICAL INFORMATION

- **The refrigerator must be plugged into its own dedicated 115 Volt, 60 Hz., AC only electric outlet.** The power cord of the appliance is equipped with a three-prong grounding plug for your protection against electrical shock hazards. It must be plugged directly into a properly grounded three-prong receptacle. The receptacle must be installed in accordance with local codes and ordinances. Consult a qualified electrician. **Do not use an extension cord or adapter plug.**
- If the power cord is damaged, it should be replaced by the manufacturer, service technician or a qualified person to prevent any risk.
- Never unplug the refrigerator by pulling on the power cord. Always grip the plug firmly, and pull straight out from the receptacle to prevent damaging the power cord.
- Unplug the refrigerator before cleaning and before replacing a light bulb to avoid electrical shock.
- Performance may be affected if the voltage varies by 10% or more. Operating the refrigerator with insufficient power can damage the compressor. Such damage is not covered under your warranty.
- Do not plug the unit into an outlet controlled by a wall switch or pull cord to prevent the refrigerator from being turned off accidentally.
- Avoid connecting refrigerator to a Ground Fault Interruptor (GFI) circuit.

IMPORTANT

Pressing and holding the **On/Off** button for 3 seconds, located on the left side of the temperature control panel, will disable your refrigerator’s cooling system, but does not disconnect the power to the light bulb and other electrical components. To turn off power to your refrigerator you must unplug the power cord from the wall outlet.

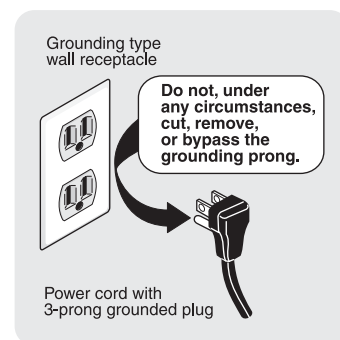



INSTALLATION

This Owner's Guide provides specific operating instructions for your model. Use the refrigerator only as instructed in this Use & Care Manual. **Before starting the refrigerator, follow these important first steps.**

LOCATION

- Choose a place that is near a grounded electrical outlet. **Do Not** use an extension cord or an adapter plug.
- If possible, place the refrigerator out of direct sunlight and away from the range, dishwasher or other heat sources.
- The refrigerator must be installed on a floor that is level and strong enough to support a fully loaded refrigerator.
- Consider water supply availability for models equipped with an automatic ice maker.

INSTALLATION



CAUTION

Do Not install the refrigerator where the temperature will drop below 55°F (13°C) or rise above 110°F (43°C). The compressor will not be able to maintain proper temperatures inside the refrigerator.

Do Not block the toe grille on the lower front of your refrigerator. Sufficient air circulation is essential for the proper operation of your refrigerator.

Installation Clearances

- Allow the following clearances for ease of installation, proper air circulation, and plumbing and electrical connections:
 - Sides & Top ----- 3/8"
 - Back ----- 1"

DOOR OPENING

NOTE

If your refrigerator is placed with the door hinge side against a wall, you may have to allow additional space so the door can be opened wider.

Your refrigerator should be positioned to allow easy access to a counter when removing food. For best use of drawers and freezer baskets, the refrigerator should be in a position where both the refrigerator and freezer doors can be fully opened.

TOE GRILLE INSTALLATION / REMOVAL

To Install Toe Grille:

1. Open freezer and fresh food compartment doors.
2. Line up toe grille at base of refrigerator, making sure the four bottom tabs are resting through holes at base of cabinet.
3. Starting from left side of toe grille, press in on first top tab using your thumb and push toe grille forward until it snaps in place. Continue this process until all tabs are snapped in place and toe grille is secured to refrigerator.

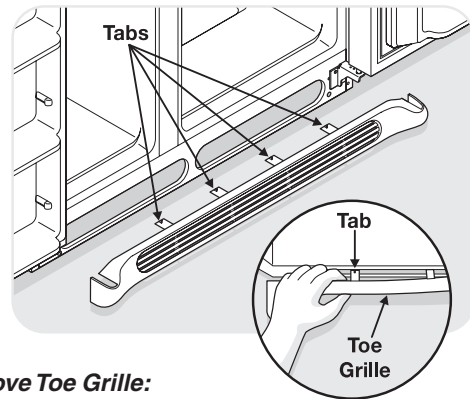

To Remove Toe Grille:

1. Open freezer and fresh food compartment doors.
2. Working from left side of toe grille, slip your fingers between top of toe grille and cabinet. Gently pull forward until first set of tabs are free. Slide your hand down past the free tabs and pull forward again until the second set of tabs are free. Continue this process until all tabs are free and the toe grille can be removed. (See graphic at top of page in right column.)

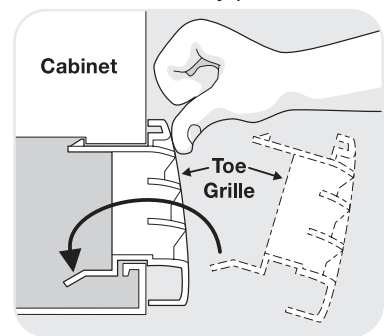

LEVELING

All four corners of your refrigerator must rest firmly on a solid floor. Your refrigerator is equipped with adjustable front rollers to help level your unit. To ensure proper door seal and assist door closing, the refrigerator should be tilted 1/4" (6 mm), front to back.

To Level Your Refrigerator:

1. Remove toe grille. (See "To Remove Toe Grille".)
2. Use flat-blade screwdriver or 3/8" socket wrench to adjust front rollers.

NOTE

The refrigerator doors are designed to shut by themselves within a 20 degree opening.

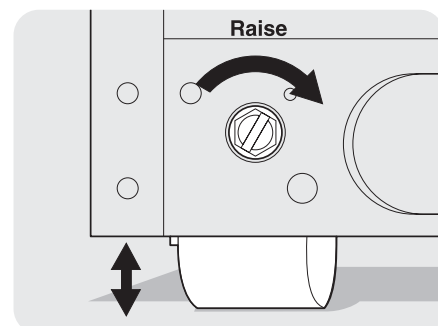

3. Check both doors to be sure seals touch cabinet on all four sides.



INSTALLATION - CONNECTING ICE MAKER TO WATER SUPPLY

! WARNING

To avoid electric shock, which can cause death or severe personal injury, disconnect the refrigerator from electrical power before connecting a water supply line to the refrigerator.

! CAUTION

To Avoid Property Damage:

- **Copper tubing is recommended for the water supply line. Water supply tubing made of ¼" plastic is not recommended since it greatly increases the potential for water leaks. Manufacturer will not be responsible for any damage if plastic tubing is used for supply line.**
- **DO NOT install water supply tubing in areas where temperatures fall below freezing.**
- **Chemicals from a malfunctioning softener can damage the ice maker. If the ice maker is connected to soft water, ensure that the softener is maintained and working properly.**

IMPORTANT

Ensure that your water supply line connections comply with all local plumbing codes.

Before Installing The Water Supply Line, You Will Need:

- **Basic Tools:** adjustable wrench, flat-blade screwdriver, and Phillips™ screwdriver
- Access to a household cold water line with water pressure between 30 and 100 psi.
- A water supply line made of ¼ inch (6.4 mm) OD, copper tubing. To determine the length of copper tubing needed, you will need to measure the distance from the ice maker inlet valve at the back of the refrigerator to your cold water pipe. Then add approximately 7 feet (2.1 meters), so the refrigerator can be moved out for cleaning (as shown).
- A shutoff valve to connect the water supply line to your household water system. **DO NOT** use a self-piercing type shutoff valve.
- A compression nut and ferrule (sleeve) for connecting the water supply line to the ice maker inlet valve.

NOTE

Water line kit number 5303917950, available from your appliance dealer at additional cost, contains 25 feet (7.6 meters) of ¼ inch OD copper tubing, a saddle type shutoff valve (nonpiercing), (2) ¼ inch brass compression nuts, (2) ferrules/sleeves, and instructions for installing a water supply line.

To Connect Water Supply Line To Ice Maker Inlet Valve

1. Disconnect refrigerator from electric power source.
2. Place end of water supply line into sink or bucket. Turn ON water supply and flush supply line until water is clear. Turn OFF water supply at shutoff valve.
3. Unscrew plastic cap from water valve inlet and discard cap.
4. Slide brass compression nut, then ferrule (sleeve) onto water supply line, as shown.
5. Push water supply line into water valve inlet as far as it will go (¼ inch). Slide ferrule (sleeve) into valve inlet and finger tighten compression nut onto valve. Tighten another half turn with a wrench; **DO NOT** over tighten.
6. With steel clamp and screw, secure water supply line to rear panel of refrigerator as shown.
7. Coil excess water supply line (about 2½ turns) behind refrigerator as shown and arrange coils so they do not vibrate or wear against any other surface.
8. Turn ON water supply at shutoff valve and tighten any connections that leak.
9. Reconnect refrigerator to electrical power source.
10. To turn ice maker on, lower wire signal arm (side mounted) or set the ice maker's On/Off power switch to the "I" position. (rear mounted)

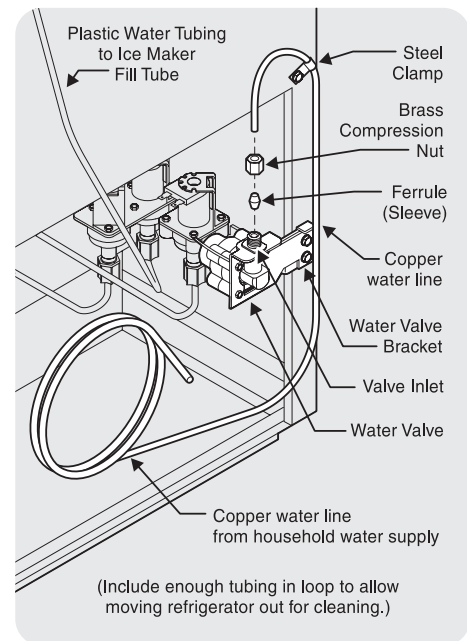

IMPORTANT

It takes approximately 24 hours for the ice maker to begin producing ice. Air in new plumbing lines may cause ice maker to cycle two or three times before making a full tray of ice. New plumbing may cause ice to be discolored or have poor flavor. Discard ice made during the first 24 hours.



DOOR REMOVAL INSTRUCTIONS

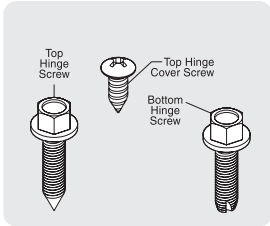

Tools Necessary:

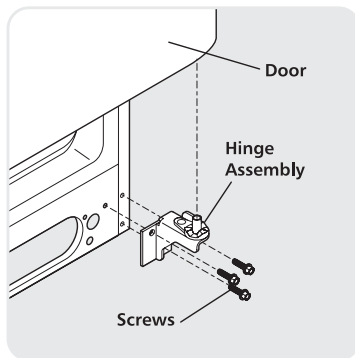
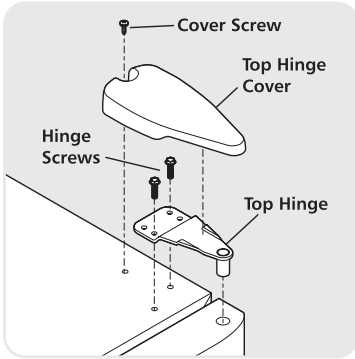
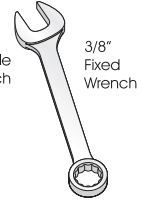
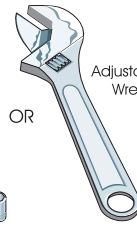
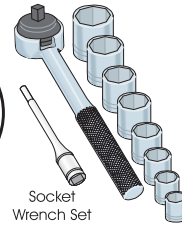
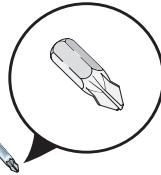
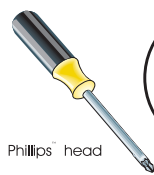

TO DISCONNECT

1. Press outer ring against face of fitting
2. Pull to remove tube

TO CONNECT

Insert tube and push until mark touches face of fitting

DOOR REMOVAL INSTRUCTIONS:

If it is necessary to move the refrigerator through narrow doorways, follow these steps to remove the doors.

NOTE

Before you begin, turn *Freezer* and *Fresh Food* controls to "OFF" by pressing and holding the **On/Off** button for 3 seconds, and remove electrical power cord from wall outlet. Remove any food from door shelves.

1. Disconnect electrical supply.
2. Open both doors, then remove toe grille.
3. Close doors.

To Remove Refrigerator Door:

1. Remove top hinge cover screw on refrigerator door and remove cover.
2. Trace around hinge with soft lead pencil. This will make it easier to realign doors when they are replaced.
3. Remove top hinge and lift refrigerator door off bottom hinge pin. Set door aside.
4. Remove bottom hinge, if necessary.
5. Reverse this procedure to reinstall refrigerator door.

To Remove Freezer Door:

1. Disconnect water line coming from lower hinge of freezer door at connection located under front of freezer: Press outer ring against face of fitting, then pull to remove tube.
2. Remove top hinge cover screw on freezer door and remove cover.
3. Disconnect wiring harness connector plug at top hinge: place your thumbs on flat sides of each connector and bend both parts back and forth, then with firm grasp, pull both pieces apart.
4. Trace around hinge with soft lead pencil. This will make it easier to realign doors when they are replaced.
5. Remove top hinge, allowing wiring harness to pull through hinge and lift freezer door off of bottom hinge pin. Lay door down flat to avoid kinking water line.
6. Remove bottom hinge, if necessary.
7. Reverse this procedure to reinstall freezer door.

When both doors have been reinstalled, connect water line by inserting tube and push until mark touches face of fitting, replace toe grille and plug in electrical power cord. Turn both temperature controls to center position. Adjust settings as necessary.

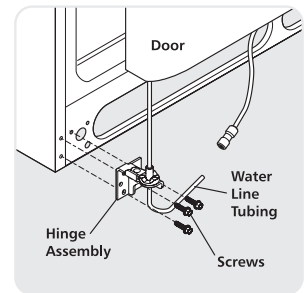
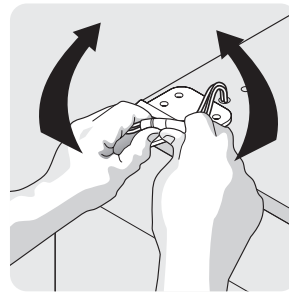
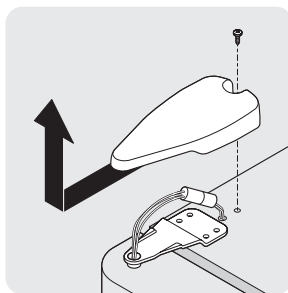



FEATURES AT A GLANCE

Features may vary according to model

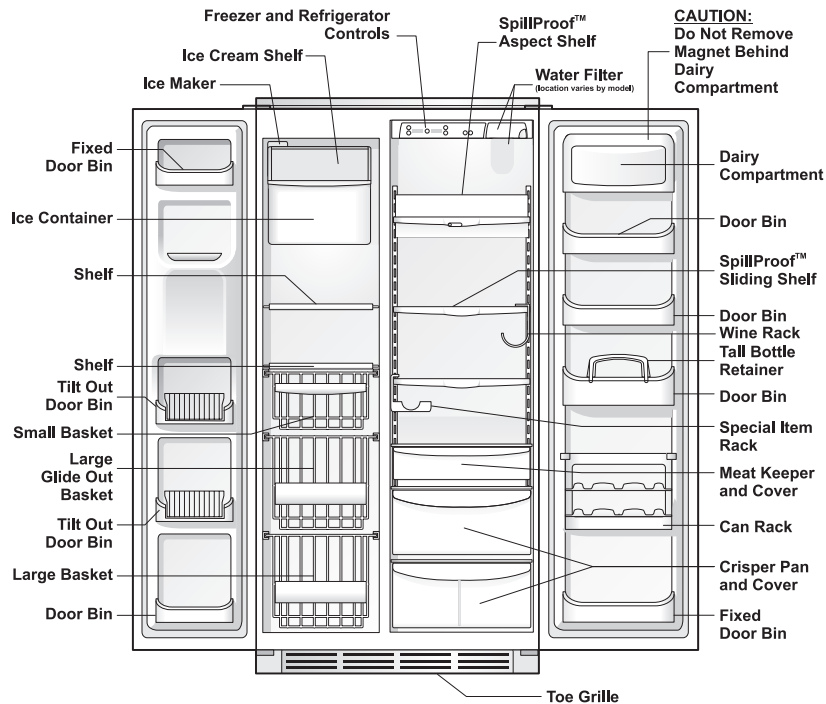

CAUTION:
Do Not Remove Magnet Behind Dairy Compartment



TEMPERATURE CONTROLS

ALLOWING COOLING TIME BEFORE USE

To ensure reliable food storage, allow your refrigerator and freezer to operate with the doors closed for 8 to 12 hours before placing food inside. During this cooling period, you do not need to adjust the controls, which are preset at the factory.

SETTING COOLING TEMPERATURES

Your refrigerator comes with a state-of-the-art electronic digital control system. The system's control panel is located at the top of the the fresh food compartment.

The two digital displays on the left half of the control panel indicate the current settings or temperatures of your freezer and fresh food compartments. The models with a 2-digit temperature display are for reference only, and do not display the current accurate compartment temperature. Should you desire to see what the current accurate temperature is, place a separate thermometer inside the freezer or fresh food compartment in the desired location.

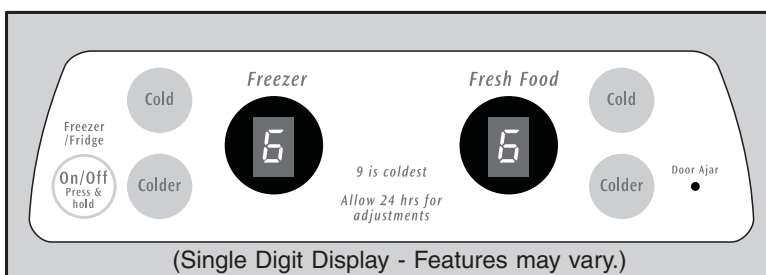
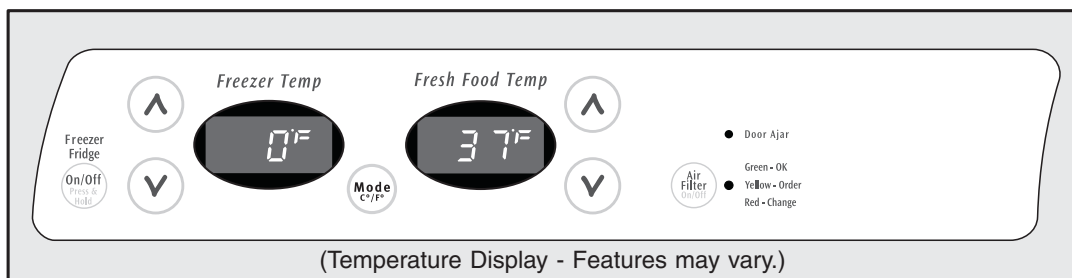

NOTE

The advanced electronic control system in your refrigerator includes additional display modes that service professionals can use to rapidly diagnose performance issues.



TEMPERATURE CONTROLS

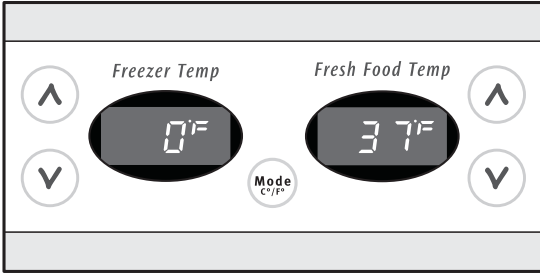

MAKING TEMPERATURE ADJUSTMENTS

After running your refrigerator for 24 hours, you can adjust temperatures as needed. Make your adjustments small and gradual, allowing time for temperatures to change and stabilize. Refer to the following guidelines for temperature settings.

WHAT TO DO IF THE TEMPERATURE DISPLAYS FLASH

If either display is continuously flashing, it may indicate that the control system has detected a performance problem. Call your Electrolux service representative, who can interpret the flashing message.

To adjust the temperature to a higher or lower setting, press the **Up (Cold)** or **Down (Colder)** button closest to the display. The first time you press the button, the display shows current setting you entered. Each press of the button after that changes the setting by one.

The display shows your new setting momentarily, then changes back to the current temperature.

CHOOSING FAHRENHEIT OR CENTIGRADE

Depending on which temperature standard you prefer to use, you can set your control panel to display in fahrenheit or centigrade. To change between fahrenheit and centigrade, press the **Mode** button (located between the two digital temperature displays).

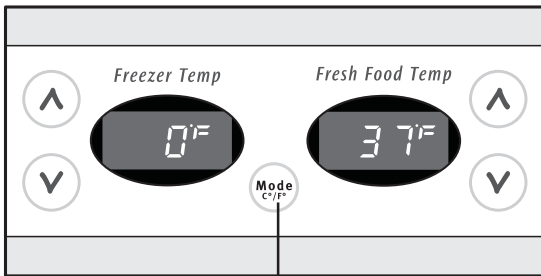

Press to alternate between Fahrenheit and Centigrade

Numeric Display

	Freezer	Fresh Food
Warmest	1	1
Factory Setting	6	6
Coldest	9	9

Temperature Display (2-Digit)

	Freezer		Fresh Food	
	F°	C°	F°	C°
Warmest	6°	-14°	47°	8°
Factory Setting	0°	-18°	37°	3°
Coldest	-6°	-21°	33°	1°

Temperature Adjustment Guide

If Fresh Food compartment is too warm	Adjust Fresh Food control one degree colder by pressing Down (Colder) button.
If Fresh Food compartment is too cold	Adjust Fresh Food control one degree warmer by pressing the Up (Cold) button.
If Freezer compartment is too warm	Adjust Freezer control one degree colder by pressing Down (Colder) button.
If Freezer compartment is too cold	Adjust Freezer control one degree warmer by pressing the Up (Cold) button.



TEMPERATURE CONTROLS

SYSTEM-MONITORING ALARMS

The electronic control system continuously monitors your refrigerator/freezer for temperature consistency and doors left ajar. Variances from normal operating conditions are communicated by audible tones and a set of two status indicator lights.

RESPONDING TO ALARMS (AUDIBLE TONES & INDICATOR LIGHTS)

Your refrigerator's control system can convey the following information through audible tones and the alarm indicator lights.

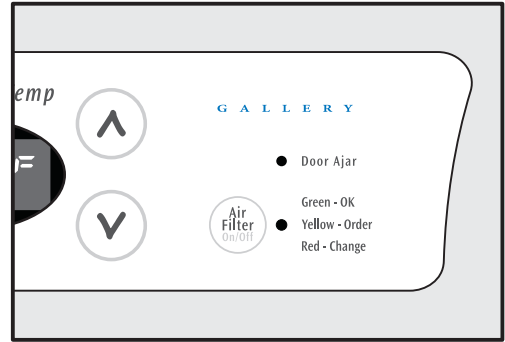

Door Ajar	Flashing Green	Freezer or Fresh Food door has been open for over five minutes.	Close door to silence and reset alarm.
------------------	----------------	---	--

AIR FILTER INDICATOR & STATUS LIGHTS

Your refrigerator's fresh food air filter needs to be replaced from time to time. You can monitor the need for replacement by referring to the status light while the air filter is "ON". To turn on the air filter, press the "Air Filter" button. To turn off the air filter, press the "Air Filter" button. To RESET the air filter, press the "Air Filter" button and hold for 3 seconds.

Air Filter Status Light (not available on all models)

Green	Filter OK.
Yellow	Air filter is about 80 percent used. Please order new one.
Red	Air filter is 100 percent used. Please change now.

TURNING THE COOLING SYSTEM ON AND OFF

You can disable the cooling system in your refrigerator by pressing the **On/Off** button located on the left side of the temperature control panel.

To ensure that you do not accidentally turn off the cooling system, the button does not work unless you press *and hold* it for three seconds.

While the cooling system is "OFF", the digital display will show "OF" "OF" for temperature display models and "O" "F" for numeric display models.

Once you disable the cooling system, all refrigeration to the freezer and fresh food compartments stops.

To turn the cooling system back on, you must again press *and hold* the **On/Off** button for three more seconds.

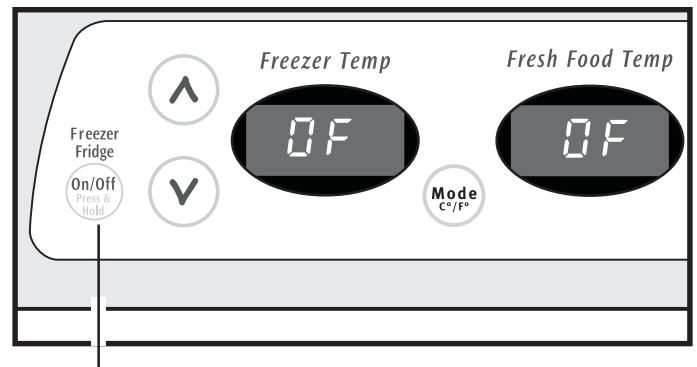

Cooling System On/Off Button

IMPORTANT

The On/Off button only controls your refrigerator's cooling system. Power to lights and other electrical components continue unless you unplug the power cord.



LOOKING INSIDE

PIZZA SHELF (SOME MODELS)

This shelf is attached to the freezer wall beside the ice dispenser container. This convenient area allows for storage of pizza and other tall items placed vertically between the ice dispenser container and the freezer wall.



ICE CREAM SHELF (SOME MODELS)

This shelf attaches to the top of the ice dispenser container. It allows storage of both round and rectangular cartons of your favorite ice cream.

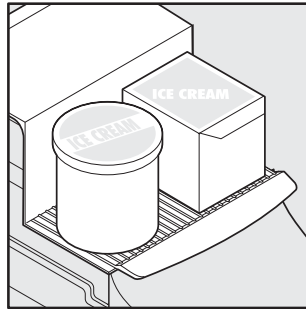

Ice Cream Shelf

TIP-UP SHELF (SOME MODELS)

A Tip-Up shelf in the freezer section allows tall items to be easily stored.

CAUTION

To avoid personal injury or property damage, handle tempered glass shelves carefully. Shelves may break suddenly if nicked, scratched, or exposed to sudden temperature change.

CANTILEVER SHELF ADJUSTMENT

Refrigerator shelves are easily adjusted to suit individual needs. Before adjusting the shelves, remove all food. Cantilever shelves are supported at the back of the refrigerator.

To adjust cantilever shelves:

- 1 Lift front edge up.
- 2 Pull shelf out.

Replace the shelf by inserting the hooks at rear of the shelf into the wall bracket. Lower the shelf into the desired slots and lock into position.

* *SpillSafe™* glass shelves (some models) catch and hold accidental spills. In some models, the * *SpillSafe™* shelves slide out for easy access to food and for fast cleaning. The shelves slide out independently of their mounting brackets. Just pull the front of the shelf forward. Shelves can be extended as far as the stopper will allow but are **not** removable from their mounting brackets.

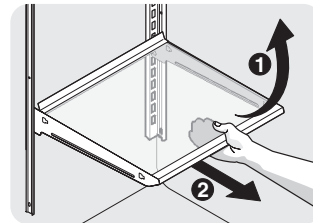

Cantilever Glass Shelf

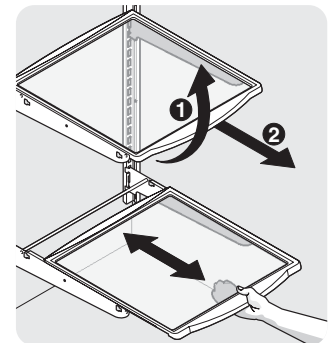

Cantilever Sliding Glass Shelf

Pizza Shelf

DOOR STORAGE

Door bins and shelves are provided for convenient storage of jars, bottles, and cans. Frequently used items can be quickly selected.

Some models have door bins that can accommodate gallon-sized plastic drink containers and economy-sized jars and containers. Some bins are adjustable for maximum storage capacity.

The dairy compartment, which is warmer than the general food storage section, is intended for short term storage of cheese, spreads, or butter.

ADJUSTABLE DOOR BINS

Some models have adjustable door bins that can be moved to suit individual needs.

To move door bins

1. Lift bin straight up.
2. Remove bin.
3. Place bin in desired position.
4. Lower bin onto supports until locked in place.

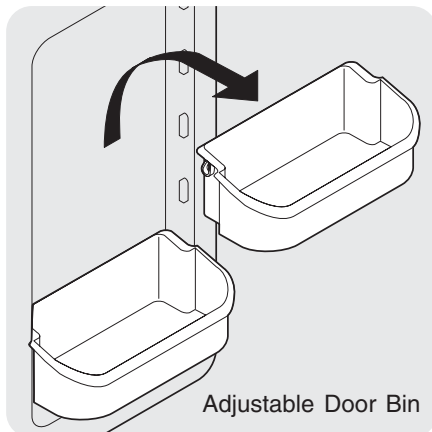

Adjustable Door Bin

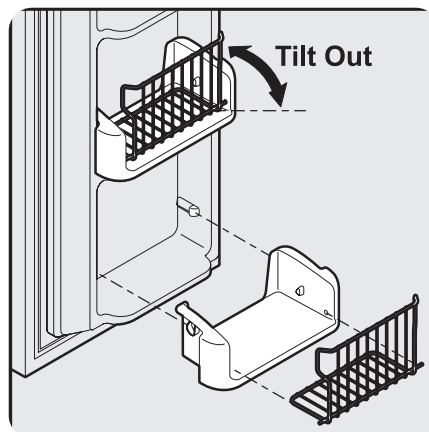

Tilt Out

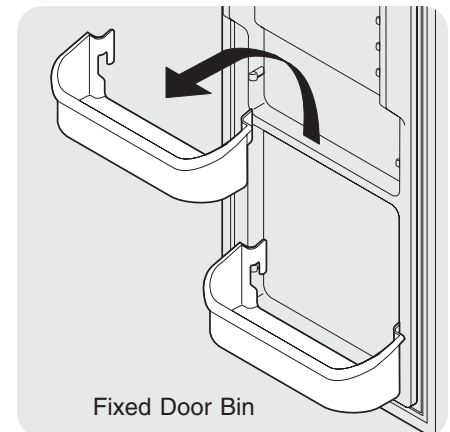

Fixed Door Bin

* WhiteWestinghouse - SpillFree™



LOOKING INSIDE (CONTINUED)

TALL BOTTLE RETAINER (SOME MODELS)

The Tall Bottle Retainer keeps tall containers in the bin from falling forward when opening or closing the refrigerator door. To install, hold the retainer at the top, and slide it over the outside wall of the bin, as shown in the diagram. The Tall Bottle Retainer works best with a Bin Snugger.

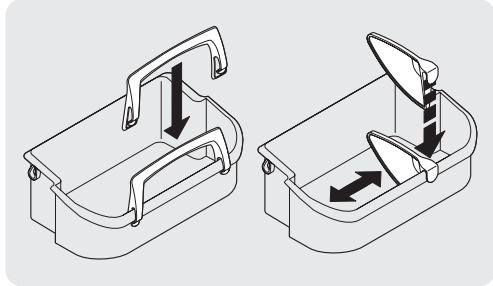

Tall Bottle Retainer (left) and Bin Snugger (right)

SPECIAL ITEM RACK (SOME MODELS)

The innovative design of the Special Item Rack allows you to store a six-pack of 12 ounce drink cans, a bottle of wine, a two-liter soft drink bottle, or a carton of eggs. The Special Item Rack mounts on the left side of your refrigerator. To install, just slide the Special Item Rack onto any shelf as shown in the drawing.

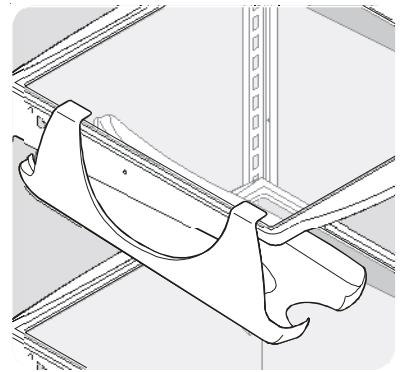

Special Item Rack



LOOKING INSIDE - SPECIAL STORAGE AREAS

CRISPERS (SOME MODELS)

The crispers, located under the bottom refrigerator shelf, are designed for storing fruits, vegetables, and other fresh produce. Wash items in clear water and remove excess water before placing them in the crispers. Items with strong odors or high moisture content should be wrapped before storing.

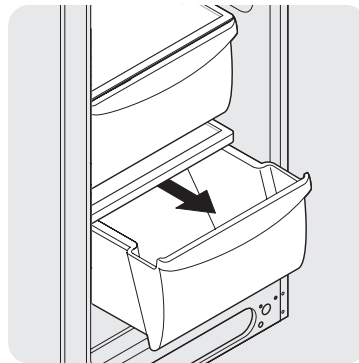

Crisper Drawer

HUMIDITY CONTROL (SOME MODELS)

The Humidity Control, present on some models with crisper drawers, allows you to adjust the humidity within the crisper. This can extend the life of fresh vegetables that keep best in high humidity.

NOTE

Leafy vegetables keep best when stored with the Humidity Control set on **Higher Humidity**, or in a drawer without a Humidity Control. This keeps incoming air to a minimum and maintains maximum moisture content.

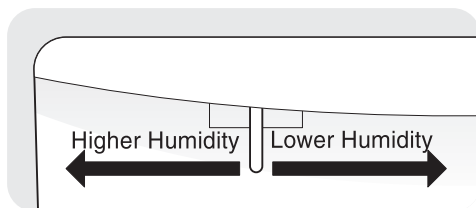

Crisper Humidity Control

DELI DRAWER (SOME MODELS)

Some models are equipped with a Deli Drawer for storage of luncheon meats, spreads, cheeses, and other deli items.

MEAT KEEPER (SOME MODELS)

Some models are equipped with a Meat Keeper. Meat Keeper temperatures can be adjusted by sliding the Meat Keeper Temperature Control in either direction. Use this pan for short term storage of bulk meat items. If meats are to be kept longer than one or two days, they should be frozen. The Meat Keeper is fixed and cannot be moved up or down. If fruits or vegetables are to be stored in the Meat Keeper, set the Meat Keeper Temperature Control to a warmer setting to prevent freezing.

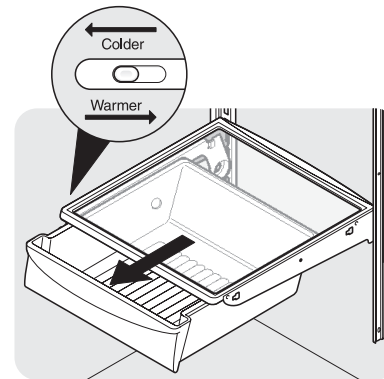

Meat Keeper with Temperature Control

WINE RACK (SOME MODELS)

The wine rack stores bottles of wine, or single two-liter plastic bottles of juice or soda pop. To install, slide the Wine Rack onto the shelf with the curve facing in. To remove, slide the Wine Rack out. Install on either side of shelf.

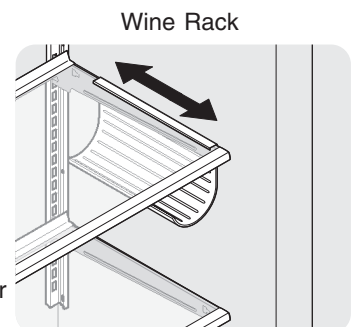

Wine Rack



AUTOMATIC ICE AND WATER DISPENSER

AUTOMATIC ICE & WATER DISPENSER OPERATING INSTRUCTIONS

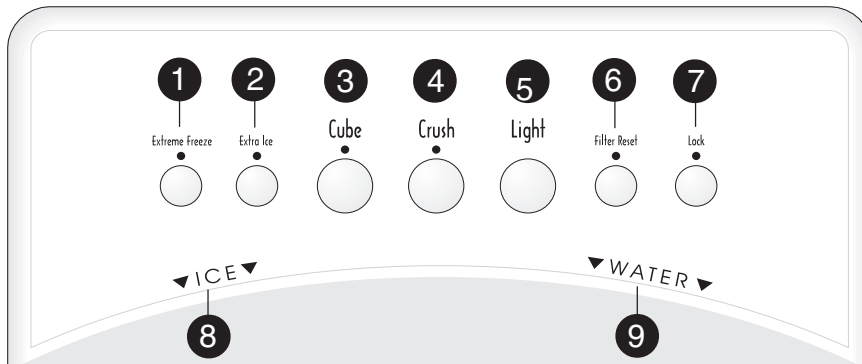

Features may vary according to model.

EXTREME FREEZE	To freeze food at a faster rate to preserve freshness, push the Touch Pad 1 for 3-5 seconds to activate this feature. A green light will appear above the Touch Pad. Push the Touch Pad 1 again for 3-5 seconds to deactivate.
EXTRA ICE	To increase ice production for special occasions, such as parties, push the Touch Pad 2 for 3-5 seconds to activate this feature. A green light will appear above the Touch Pad. Push the Touch Pad 2 again for 3-5 seconds to deactivate.
CUBE	Press the CUBE Touch Pad 3 to get cubed ice. A green light will appear above the Touch Pad. Press glass against ICE dispensing paddle 8 as far up as possible to catch all ice.
CRUSH	Press the CRUSH Touch Pad 4 to get crushed ice. A green light will appear above the Touch Pad.
LIGHT	Press glass against ICE dispensing paddle 8 as far up as possible to catch all ice. Press the LIGHT Touch Pad 5 to turn on dispenser light. Press 5 again to turn the light off. The light also turns on automatically when ice and/or water is dispensed. Replace light bulb with an appliance bulb of the same wattage.
FILTER STATUS	The FILTER STATUS indicator light above the Touch Pad 6 will light up each time the dispenser is used. The following filter light indications are: Green The filter is still operating within its specified life cycle. Amber The filter has reached approximately 80% of its useful life. This is the recommended time to purchase a replacement filter. Red The filter is 100% used up. Change the filter as soon as possible. After the filter cartridge has been changed, press and hold the FILTER RESET Touch Pad 6 for 10-15 seconds. NOTE: The Green, Red and Amber lights will flash when reset is completed.
LOCK	The Ice & Water Dispenser can be locked out to prevent unwanted use. To Lock Out Press the LOCK Touch Pad 7 for 3-5 seconds. A Red light will appear above the Touch Pad. To Unlock Press the LOCK Touch Pad 7 for 3-5 seconds until the Red light above the Touch Pad goes out.
WATER	To operate the water dispenser , press a glass against the WATER dispensing paddle 9 . To stop dispensing water, pull the glass away from the dispensing paddle 9 . Dispensed water is not cold. For colder water, add crushed ice or cubes before dispensing water. A drip tray located at the base of the dispenser catches small spills and allows them to evaporate. This drip tray is removable and dishwasher safe. Do not pour water and excess ice in this area because there is no drain.



AUTOMATIC ICE AND WATER DISPENSER

HOW THE WATER DISPENSER WORKS

The water tank, located behind the drawers in the refrigerator compartment, automatically fills as water is dispensed. For proper dispenser operation, the recommended supply water pressure should fall between 30 psi and 100 psi.

After the refrigerator is connected to the water supply, fill the water tank by drawing one glass of water. **It may take about 1½ minutes** after activating the dispenser paddle before water begins to fill this first glass. Continue flushing the system for 3 minutes to rid the tank and plumbing connections of any impurities. The water dispenser has a built in shutoff device that will stop the water flow after 3 minutes of continuous use. Simply release the dispenser paddle to reset the shutoff mechanism.

CAUTION

Water pressure must not exceed 100 lbs. Excessive pressure may cause water filter to malfunction.

Chemicals from a malfunctioning softener can damage the ice maker. If the ice maker is connected to soft water, ensure that the softener is maintained and working properly.

HOW THE ICE DISPENSER WORKS -SIDE MOUNTED

The ice maker and container are located in the top of the freezer compartment. After the refrigerator is installed properly and has cooled for several hours, the ice maker can begin making ice within 24 hours. Air in new plumbing lines may cause the ice maker to cycle two or three times before making a full tray of ice. To begin ice production, lower the wire signal arm to the "down" or ON position. With no usage it will take approximately 2 days to fill the ice container.

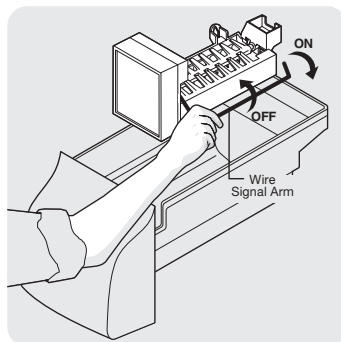

The ice maker turns off automatically when the ice container becomes full. To stop the ice maker, lift the wire signal arm until it clicks, and locks in the "up" or OFF position.

HOW THE ICE DISPENSER WORKS -REAR MOUNTED

The ice maker and container are located in the top of the freezer compartment. After the refrigerator is installed properly and has cooled for several hours, the ice maker can begin making ice within 24 hours. Air in new plumbing lines may cause the ice maker to cycle two or three times before making a full tray of ice. Ice production is controlled by the ice maker's On/Off power switch. To gain access



to the ice maker, pull the ice cream tray out. Press the switch to the "O" position to turn it Off and press it to the "I" position to turn it On. With no usage it will take approximately 2 days to fill the ice container. The ice maker also has a built-in wire signal arm, which automatically stops ice production when the ice bin is full. This signal arm should not be used to manually stop the ice maker.

The ice maker produces 4 to 6 pounds of ice every 24 hours depending on usage conditions. Ice is produced at a rate of 8 cubes every 75 to 90 minutes.

Because of new plumbing connections, the first production of ice cubes may be discolored or have an odd flavor. These should be discarded until the cubes made are free of discoloration and taste.

ICE AND WATER DISPENSER FEATURES

The ice and water dispenser conveniently dispenses chilled water, and ice cubes or crushed ice, depending on the model.

To operate the ice dispenser, select the ice option desired using the touchpad. Press a glass against the dispensing paddle as far up as possible to catch all ice. To stop dispensing ice, pull glass away from dispensing paddle. Do not remove the glass until the ice has completely dispensed. (Complete instructions for the dispenser operation are attached to the inside of the freezer door.)

ICE DISPENSER TIPS

- Ice cubes stored too long may develop an odd flavor. Empty the ice container and ensure that the wire signal arm is in its "down" or ON position (side mounted) or the ice maker's On/Off power switch is turned On-set to the "I" position (rear mounted). The ice maker will then produce more ice.
- Occasionally shake the ice container to keep ice separated.
- Keep the wire signal arm in its "up" or OFF position (side mounted) or the ice maker's On/Off power switch turned Off-set to the "O" position (rear mounted) until the refrigerator is connected to the water supply or whenever the water supply is turned off.

IMPORTANT

Your ice maker is shipped with the wire signal arm in the ON position (side mounted) or turned ON (rear mounted) at the factory. To ensure proper function of your ice maker, hook up water supply immediately or turn ice maker OFF by lifting the wire signal arm until it clicks and locks in the UP position (side mounted) or turn the On/Off switch to the Off ("O") position. If the icemaker is not turned off and the water supply is not connected, the water valve will make a loud chattering noise.



AUTOMATIC ICE AND WATER DISPENSER

CAUTION

If the dispensing paddle is pushed for more than 4 minutes, the dispenser motor may overload and stop. The overload protector will reset automatically after 3 or 4 minutes.

- If a large quantity of ice is needed at one time, it is best to remove cubes directly from the ice container.
- The following sounds are normal when the ice maker is operating:
 - Motor running
 - Ice dropping into ice container
 - Water valve opening or closing
 - Ice loosening from tray
- Running water
- Stop the ice maker when cleaning the freezer and during vacations.
- If the ice maker will be turned off for a long period of time, turn the water supply valve to the closed position.

CLEANING THE ICE DISPENSER

Clean the dispenser and ice container at regular intervals, particularly before you take a vacation or move, or if the ice dispenser sticks.

1. Stop ice production by lifting the wire signal arm to the "up" or OFF position (side mounted) or the ice maker's On/Off power switch turned Off-set to the "O" position (rear mounted) .
2. Remove ice container by lifting up and out. Empty and carefully clean the container with **mild** detergent. Rinse with clear water. Do not use harsh or abrasive cleaners. Allow ice container to dry completely before replacing in the freezer.
3. Remove ice chips and clean the shelf and chute that supports the ice container.
4. Replace the ice container. Lower the wire signal arm on the ice maker to the "down" or ON position (side mounted) or the ice maker's On/Off power switch is turned On-set to the "I" position. (rear mounted)and the ice maker will resume production.

WARNING

Do not use the ice chute as a handle when removing or replacing the ice storage bin. Surfaces there may be sharp.

Do not put fingers up ice chute. Surfaces there may be sharp.

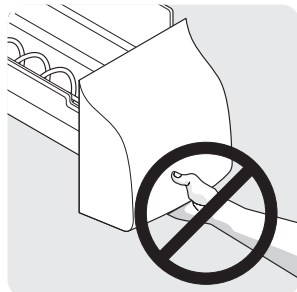

IMPORTANT

When removing or replacing the ice bin, do not rotate the auger in the ice bin. If the auger is accidentally turned, you must realign the auger by turning it in 90° turns until the ice bin fits into place with the drive mechanism.

Remove and empty the ice storage bin if:

1. An extended power failure (one hour or longer) causes ice cubes in the ice storage bin to melt and freeze together and jam the dispenser mechanism.
2. The ice dispenser is not used frequently. Ice cubes will freeze together in the bin and jam the dispenser mechanism. Remove the ice storage bin and shake to loosen the cubes.

CAUTION

NEVER use an ice pick or similar sharp instrument to break up the ice. This could damage the ice storage bin and dispenser mechanism.

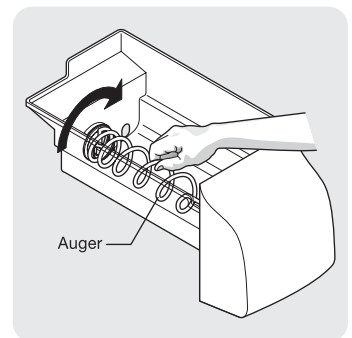



AUTOMATIC ICE AND WATER DISPENSER

PURESOURCE™ * ICE AND WATER FILTER (SOME MODELS)

System Startup:

Water supply does not need to be turned off, however, do not use ice and water dispenser while installing filter. The filter cartridge has already been installed in the filter housing at the factory. Refer to the *How The Water Dispenser Works* section to properly fill the system with water.

NOTE

If you purchased a refrigerator with a *PureSource™* * Ice and Water filter, please read the following use and care information. This ice and water filter system filters water to your ice maker and water dispenser. It is located in the upper right back corner of the fresh food compartment.

Order new filter cartridges through the dealer where you bought the refrigerator, contact the *Consumer Assistance Center* at 1-800-944-9044, or go to our web site at www.frigidaire.com. It might be good to order some filter cartridges when you first install your refrigerator. Be sure to ask for the RG-100 *PureSource™** replacement cartridge.

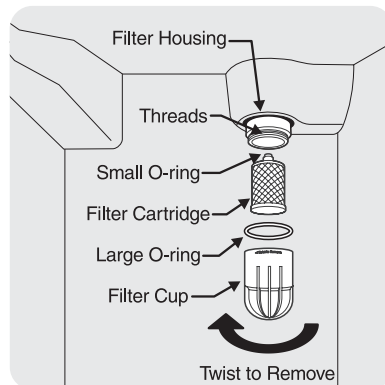

The *PureSource™* * NGRG-2000 Ice and Water Filter System with the RG-100 cartridge is tested and certified by NSF International, the nationally recognized and respected, not for profit, certification organization for public health safety.

The *PureSource™** system is tested and certified to ANSI/NSF Standard 42. See performance data sheet for specifications. This system should not be used on water that is microbiologically unsafe or with water of unknown quality unless the water has been adequately disinfected before or after traveling through the filtration system.

- Rated Capacity - 400 gallons
- Rated service flow - .5 GPM
- Maximum Rated Pressure - 100 PSI
- Maximum Operating Temp. - 100° F

Changing the Filter:

Water conditions vary throughout the world, but changing the water filter every 6 - 9 months normally will ensure the highest possible water quality. The Filter Status light will turn red after 400 gallons of water has flowed through the ice and water dispenser (some models). Also, if the filter has been in a refrigerator that has not been in use for awhile (during moving for example), change the filter before reinstalling the refrigerator.

* White Westinghouse uses the name CrystalClear instead of PureSource, but they are the same filter.

The dispenser system will also operate without filtration (with filter cartridge removed).

To change filter:

It is not necessary to turn the water supply off to change the filter.

1. Open freezer door and leave open until filter change is complete.
2. Set ice maker wire signal arm to the OFF (up) position (side mounted) or the ice maker's On/Off power switch turned Off-set to the "O" position (rear mounted) .
3. Hold filter cup firmly, and unscrew towards left (Some water could leak out as you remove cup. This is normal.). Filter cartridge should come down with cup. If cartridge remains in housing, pull down gently, while twisting filter back and forth.
4. Rinse out cup under running water.
5. The large o-ring that seals the filter system sets in the o-ring groove down inside the cup. Should the o-ring fall out during filter cartridge replacement, simply place it back in the groove prior to screwing the cup back in place. If the o-ring becomes damaged, you will need to order one from the *Consumer Assistance Center*.
6. Discard old filter cartridge.
7. Remove new filter cartridge from packaging. Place in cup. The end with the small o-ring should be up, out of the cup.
8. Screw cup, with filter, back onto housing. **Do Not Use Wrench To Reinstall Cup.** Filter cartridge will self-align as cup is tightened. Be sure cup is completely tightened with *PureSource™* logo facing outward. **Do Not Tighten Past Stop.**
9. Set ice maker wire signal arm to the ON (down) position (side mounted) or the ice maker's On/Off power switch is turned On-set to the "I" position. (rear mounted).
10. Check for leaks. Open refrigerator door. Wipe any water droplets from the filter cup. Fill a glass with water. If there is a leak, unscrew filter cup, and reinsert the filter cartridge. Check placement of large O-ring. Reinstall filter cup, making certain it is tightened completely.
11. To condition filter system and purge air from water line, fill a glass with water. Continue flushing the system for approximately 3 minutes to assure that the purest water possible is stored in the water tank.

IMPORTANT

Resetting The Filter Status Light (some models)

After replacing the filter cartridge, it will be necessary to press the *Filter Status* reset button located on the ice and water dispenser. This will reset the Filter Status light. Push the reset button until the green, red and amber lights flash (10-15 seconds). Please refer to the complete dispenser operating instructions attached to the inside of the freezer door.

On models without a *Filter Status* reset button, there is a set of Reminder Stickers included in the envelope that the Use & Care Manual came in. Choose a dated sticker that indicates 6 - 9 months (depending on your water quality and usage) from the date of installation. Place the sticker on the front of the filter cup to remind you when it is time to change the filter.



AUTOMATIC ICE AND WATER DISPENSER

PURESOURCE2™* ICE AND WATER FRONT FILTER (SOME MODELS)

NOTE

If you purchased a refrigerator with a *PureSource2™* Ice and Water front filter, please read the following use and care information. This ice and water filter system filters water to your ice maker and water dispenser. It is located in the upper right front corner of the fresh food compartment.

System Startup:

Water supply does not need to be turned off, however, do not use ice and water dispenser while installing filter.

The filter cartridge has already been installed in the filter housing at the factory. Refer to the *How The Water Dispenser Works* section to properly fill the system with water.

Order new filter cartridges through the dealer where you bought the refrigerator, contact the *Consumer Assistance Center* at 1-800-944-9044, or go to our web site at www.frigidaire.com. It might be good to order some filter cartridges when you first install your refrigerator. Be sure to ask for the FC-100 *PureSource™** replacement cartridge.

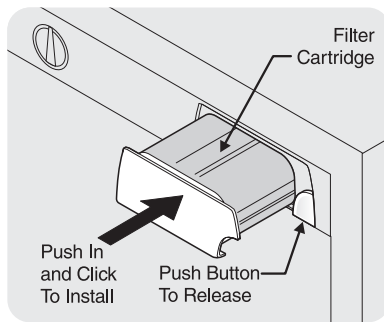

The *PureSource2™* Ice and Water Filter System NGFC 2000 with the *PureSource2™* cartridge FC 100 is tested and certified by NSF International, the nationally recognized and respected, not for profit, certification organization for public health safety. The *PureSource2™* Filter system is tested and certified to ANSI/NSF Standards 42 and 53. See performance data sheet for specifications. This system should not be used on water that is microbiologically unsafe or with water of unknown quality unless the water has been adequately disinfected before or after traveling through the filtration system.

- Rated Capacity - 400 gallons
- Rated service flow - .5 GPM
- Maximum Rated Pressure - 100 PSI
- Maximum Operating Temp. - 100° F

Changing the Filter:

Water conditions vary throughout the world, but changing the water filter every

6 - 9 months normally will ensure the highest possible water quality. The Filter Status light will turn red after approximately 400 gallons of water has flowed through the ice and water dispenser. Also, if the filter has been in a refrigerator that has not been in use for awhile (during moving for example), change the

* White Westinghouse uses the name CrystalClear instead of PureSource, but they are the same filter.

filter before reinstalling the refrigerator. The dispenser system will also operate without filtration (with filter cartridge removed and bypass installed).

To change filter:

It is not necessary to turn the water supply off to change the filter.

1. Set ice maker wire signal arm to the OFF (up) position (side mounted) or the ice maker's On/Off power switch turned Off-set to the "O" position (rear mounted) .
2. Push the *Filter Release Button*, located to the right of the filter cartridge, to release the filter from the housing. To minimize the possibility of the filter falling out of the housing during removal, it would be best to hold the filter as it moves out toward you.

NOTE

A small amount of water may be released during this operation. You should have a paper towel or dish cloth handy to wipe up any water that may drip out of the filter or housing. Two small holes near the back of the housing have been added for any excess water to escape. It would be best to clear away any food near this area on the top shelf in advance of removing the filter.

3. Pull the old filter cartridge straight out of the housing.
4. Discard the old filter.
5. Remove the new filter cartridge from the packaging and insert into the filter housing the same way the old one came out.
6. When the cartridge is almost in, you will feel it stop against the clip assembly in the back of the housing. The clip assembly holds the filter cartridge firmly in place. At this point, you will need to push firmly until the cartridge snaps fully in place. When completely in place, the front of the filter cartridge will be flush with the front of the housing.
7. Set ice maker wire signal arm to the ON (down) position (side mounted) or the ice maker's On/Off power switch is turned On-set to the "I" position. (rear mounted).
8. Fill a glass with water. As you are doing this, check for leaks at the filter housing. There will be noticeable spurts and sputters as the system pushes the air out through the system and out the dispenser nozzle. This is normal.
9. After you have run one glass of water, continue to flush the system for approximately 3 minutes to assure that the purest water possible is stored in the water storage tank.

IMPORTANT

Resetting The Filter Status Light (some models)

After replacing the filter cartridge, it will be necessary to press the *Filter Reset* button located on the ice and water dispenser. This will reset the Filter Status light. Push the reset button until the green, red and amber lights flash (10-15 seconds). Please refer to the complete dispenser operating instructions attached to the inside of the freezer door.



AUTOMATIC ICE AND WATER DISPENSER

PURESOURCE MB ICE AND WATER FRONT FILTER (SOME MODELS)

NOTE

If you purchased a refrigerator with a *PureSource MB Ice and Water front filter*, please read the following use and care information. This ice and water filter system filters water to your ice maker and water dispenser. It is located in the upper right front corner of the fresh food compartment.

System Startup:

Water supply does not need to be turned off, however, do not use ice and water dispenser while installing filter.

The filter cartridge has already been installed in the filter housing at the factory. Refer to the *How The Water Dispenser Works* section to properly fill the system with water.

Order new filter cartridges through the dealer where you bought the refrigerator, contact the *Consumer Assistance Center* at 1-800-944-9044, or go to our web site at www.frigidaire.com. It might be good to order some filter cartridges when you first install your refrigerator. Be sure to ask for the *WP2CBMB* replacement cartridge.

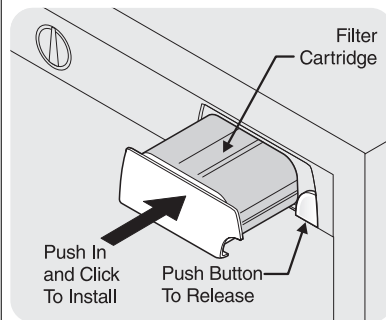

The *PureSource MB Ice and Water Filter System* MBFC 2003 with the *PureSource MB* cartridge WF2CBMB is tested and certified by NSF International, the nationally recognized and respected, not for profit, certification organization for public health safety. The *PureSource MB* Filter system is tested and certified to ANSI/NSF Standards 42 and 53. See performance data sheet for specifications. This system should not be used on water that is microbiologically unsafe or with water of unknown quality unless the water has been adequately disinfected before or after traveling through the filtration system.

- Rated Capacity - 250 gallons
- Rated service flow - .5 GPM
- Maximum Rated Pressure - 100 PSI
- Maximum Operating Temp. - 100° F

Changing the Filter:

Water conditions vary throughout the world, but changing the water filter every 6 - 9 months normally will ensure the highest possible water quality. The Filter Status light will turn red after approximately 250 gallons of water has flowed through the ice and water dispenser. Also, if the filter has been in a refrigerator that has not been in use for awhile (during moving for example), change the

* White Westinghouse uses the name CrystalClear instead of PureSource, but they are the same filter.

filter before reinstalling the refrigerator. The dispenser system will also operate without filtration (with filter cartridge removed and bypass installed).

To change filter:

It is not necessary to turn the water supply off to change the filter.

1. Set ice maker wire signal arm to the OFF (up) position (side mounted) or the ice maker's On/Off power switch turned Off-set to the "O" position (rear mounted).
2. Push the *Filter Release Button*, located to the right of the filter cartridge, to release the filter from the housing. To minimize the possibility of the filter falling out of the housing during removal, it would be best to hold the filter as it moves out toward you.

NOTE

A small amount of water may be released during this operation. You should have a paper towel or dish cloth handy to wipe up any water that may drip out of the filter or housing. Two small holes near the back of the housing have been added for any excess water to escape. It would be best to clear away any food near this area on the top shelf in advance of removing the filter.

3. Pull the old filter cartridge straight out of the housing.
4. Discard the old filter.
5. Remove the new filter cartridge from the packaging and insert into the filter housing the same way the old one came out.
6. When the cartridge is almost in, you will feel it stop against the clip assembly in the back of the housing. The clip assembly holds the filter cartridge firmly in place. At this point, you will need to push firmly until the cartridge snaps fully in place. When completely in place, the front of the filter cartridge will be flush with the front of the housing.
7. Set ice maker wire signal arm to the ON (down) position (side mounted) or the ice maker's On/Off power switch is turned On-set to the "I" position. (rear mounted).
8. Fill a glass with water. As you are doing this, check for leaks at the filter housing. There will be noticeable spurts and sputters as the system pushes the air out through the system and out the dispenser nozzle. This is normal.
9. After you have run one glass of water, continue to flush the system for approximately 3 minutes to assure that the purest water possible is stored in the water storage tank.

IMPORTANT

Resetting The Filter Status Light (some models)

After replacing the filter cartridge, it will be necessary to press the *Filter Reset* button located on the ice and water dispenser. This will reset the Filter Status light. Push the reset button until the green, red and amber lights flash (10-15 seconds). Please refer to the complete dispenser operating instructions attached to the inside of the freezer door.



FOOD STORAGE & ENERGY SAVING IDEAS

FOOD STORAGE IDEAS

Fresh Food Storage

- The fresh food compartment should be kept between 34° F and 40° F with an optimum temperature of 37° F.
- Avoid overcrowding the refrigerator shelves. This reduces the circulation of air around the food and results in uneven cooling.

Fruits and Vegetables

- Storage in the crisper drawers traps moisture to help preserve the fruit and vegetable quality for longer time periods.

Meat

- Raw meat and poultry should be wrapped securely so leakage and contamination of other foods or surfaces does not occur.

Frozen Food Storage

- The freezer compartment should be kept at 0° F or lower.
- A freezer operates most efficiently when it is at least 2/3 full.

Packaging Foods for Freezing

- To minimize dehydration and quality deterioration, use aluminum foil, freezer wrap, freezer bags or airtight containers. Force as much air out of the packages as possible and seal them tightly. Trapped air can cause food to dry out, change color, and develop an off-flavor (freezer burn).
- Wrap fresh meats and poultry with suitable freezer wrap prior to freezing.
- Do not refreeze meat that has completely thawed.

Loading the Freezer

- Avoid adding too much warm food to the freezer at one time. This overloads the freezer, slows the rate of freezing, and can raise the temperature of frozen foods.
- Leave a space between the packages, so cold air can circulate freely, allowing food to freeze as quickly as possible.
- Avoid storing hard-to-freeze foods such as ice cream and orange juice on the freezer door shelves. These foods are best stored in the freezer interior where the temperature varies less.



ENERGY SAVING IDEAS

- Locate the refrigerator in the coolest part of the room, out of direct sunlight, and away from heating ducts or registers. Do not place the refrigerator next to heat-producing appliances such as a range, oven, or dishwasher. If this

is not possible, a section of cabinetry or an added layer of insulation between the two appliances will help the refrigerator operate more efficiently.

- Level the refrigerator so that the doors close tightly.
- Refer to this Use & Care Manual for the suggested temperature control settings.
- Periodic cleaning of the condenser will help the refrigerator run more efficiently. See the *Care and Cleaning Chart* on page 20.
- Do not overcrowd the refrigerator or block cold air vents. Doing so causes the refrigerator to run longer and use more energy.
- Cover foods and wipe containers dry before placing them in the refrigerator. This cuts down on moisture build-up inside the unit.
- Organize the refrigerator to reduce door openings. Remove as many items as needed at one time and close the door as soon as possible.



NORMAL OPERATING SOUNDS & SIGHTS

UNDERSTANDING THE SOUNDS YOU MAY HEAR

Your new high-efficiency refrigerator may make unfamiliar sounds. These are all normal sounds and soon will become familiar to you. They also indicate your refrigerator is operating as designed. Hard surfaces, such as vinyl or wood floors, walls, and kitchen cabinets may make sounds more noticeable. Listed below are descriptions of some of the most common sounds you may hear, and what is causing them.

NOTE

Rigid foam insulation is very energy efficient, but is not a sound insulator.

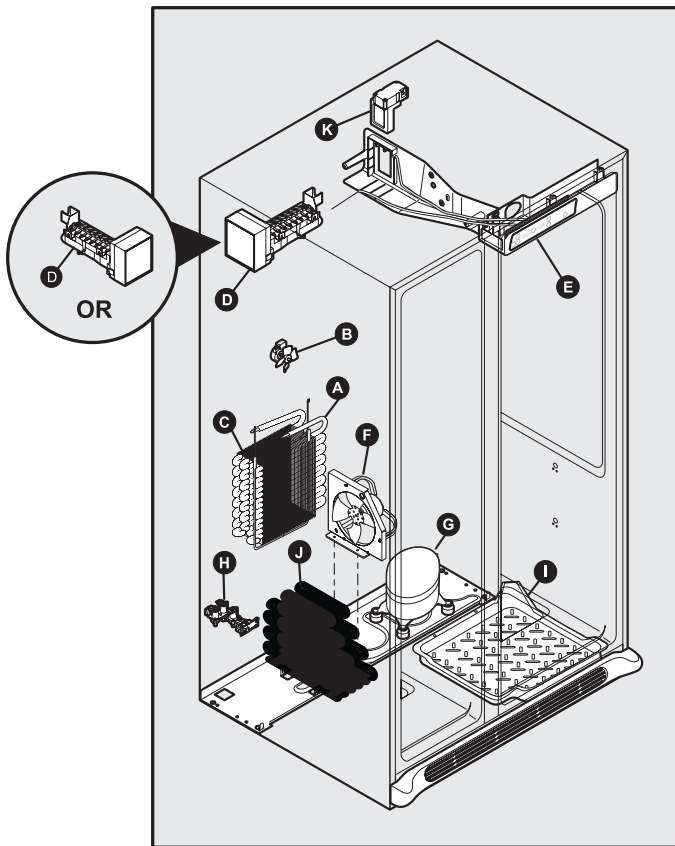

A. Evaporator

The flow of refrigerant through the evaporator may create a boiling or gurgling sound.

B. Evaporator Fan

You may hear air being forced through the refrigerator by the evaporator fan.

C. Defrost Heater

During defrost cycles, water dripping onto the defrost heater may cause a hissing or sizzling sound. After defrosting, a popping sound may occur.

IMPORTANT

During the automatic defrost cycle, you may notice a red glow in the vents on the back wall of your freezer compartment. This is normal during the defrost cycle.

D. Automatic Ice Maker

If your refrigerator is equipped with an automatic ice maker, you will hear ice cubes falling into the ice bin.

E. Cold Control & Automatic Defrost Control

These parts can produce a snapping or clicking sound when turning the refrigerator on and off.

F. Condenser Fan

You may hear air being forced through the condenser by the condenser fan.

G. Compressor

Modern, high-efficiency compressors operate much faster than older models. The compressor may have a high-pitched hum or pulsating sound.

H. Water Valve

If your refrigerator is equipped with an automatic ice maker, you will hear a buzzing sound as the water valve opens to fill the ice maker during each cycle.

IMPORTANT

Your ice maker is turned On at the factory so it can work as soon as you install your refrigerator. To ensure proper function of your ice maker, connect a water supply immediately or turn the Ice maker off by lifting the wire signal arm to the "up" or OFF position (side mounted) or the ice maker's On/Off power switch turned Off-set to the "O" position (rear mounted) .

I. Drain Pan (not removable)

You may hear water running into the drain pan during the defrost cycle.

J. Condenser

May create minimal sounds from forced air.

K. Motorized Damper

May produce a light humming during operation.



CARE & CLEANING

Keep your refrigerator and freezer clean to prevent odor build-up. Wipe up any spills immediately and clean both sections at least twice a year. **Never** use metallic scouring pads, brushes, abrasive cleaners or strong alkaline solutions on any surface. **Do not** wash any removable parts in a dishwasher. **Always unplug the electrical power cord from the wall outlet before cleaning.**

CAUTION

- When moving the refrigerator, pull straight out. Do not shift the refrigerator from side to side as this may damage the floor. Be careful not to move the refrigerator beyond the plumbing connections.
- Damp objects stick to cold metal surfaces. Do not touch refrigerated surfaces with wet or damp hands.
- Never use CHLORIDE to clean stainless steel.

NOTE

- The On/Off button on the Electronic Control only controls your refrigerator's cooling system. To turn off power to your refrigerator you must unplug the power cord from the wall outlet.
- Do not use razor blades or other sharp instruments which can scratch the appliance surface when removing adhesive labels. Any glue left from tape or labels can be removed with a mixture of warm water and mild detergent, or, touch the glue residue with the sticky side of tape you have already removed. **Do not remove the serial plate.**

Care & Cleaning Chart

Part	What To Use	Tips and Precautions
Interior/Door Liner	<ul style="list-style-type: none"> • Soap and water • Baking soda and water 	Use 2 tablespoons of baking soda in 1 quart of warm water. Be sure to wring excess water out of sponge or cloth before cleaning around controls, light bulb or any electrical part.
Door Gaskets	<ul style="list-style-type: none"> • Soap and water 	Wipe gaskets with a clean soft cloth.
Drawers/Bins	<ul style="list-style-type: none"> • Soap and water 	Do not wash any removable items (bins, drawers, etc.) in dishwasher.
Glass Shelves	<ul style="list-style-type: none"> • Soap and water • Glass cleaner • Mild liquid sprays 	Allow glass to warm to room temperature before immersing in warm water.
Toe Grille	<ul style="list-style-type: none"> • Soap and water • Mild liquid sprays • Vacuum attachment 	Vacuum dust from front of toe grille. Remove toe grille (See illustration on page 4). Vacuum backside and wipe with sudsy cloth or sponge. Rinse and dry.
Exterior and Handles	<ul style="list-style-type: none"> • Soap and water • Non Abrasive Glass Cleaner 	Do not use commercial household cleaners, ammonia, or alcohol to clean handles. Use a soft cloth to clean smooth handles. Do Not use a dry cloth to clean smooth doors.
Exterior and Handles (Stainless Steel Models Only)	<ul style="list-style-type: none"> • Soap and water • Ammonia • Stainless Steel Cleaners 	<p> CAUTION Never use CHLORIDE to clean stainless steel.</p> <p>Clean stainless steel front and handles with non-abrasive soapy water and a dishcloth. Rinse with clean water and a soft cloth. Wipe stubborn spots with an ammonia-soaked paper towel, and rinse. Use a non-abrasive stainless steel cleaner. These cleaners can be purchased at most home improvement or major department stores. Always follow manufacturer's instructions.</p> <p>NOTE: Always clean, wipe and dry with the grain to prevent cross-grain scratching. Wash the rest of the cabinet with warm water and mild liquid detergent. Rinse well, and wipe dry with a clean soft cloth.</p>



CARE & CLEANING (CONTINUED)

CAUTION

Wear gloves when replacing light bulbs to avoid getting cut.

REPLACING LIGHT BULBS

1. Unplug refrigerator.
2. Wear gloves as protection against possible broken glass.
3. Remove light cover, if necessary.
4. Unscrew and replace old bulb with an appliance bulb of the same wattage.
5. Replace light cover, if necessary.
6. Remember to plug the refrigerator back in.

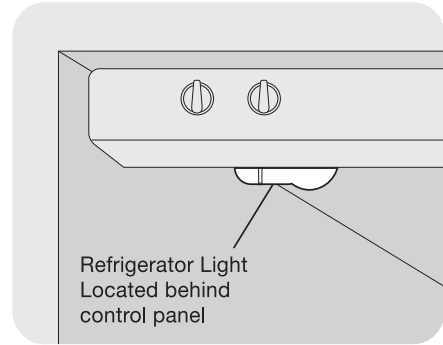

Refrigerator Light Replacement

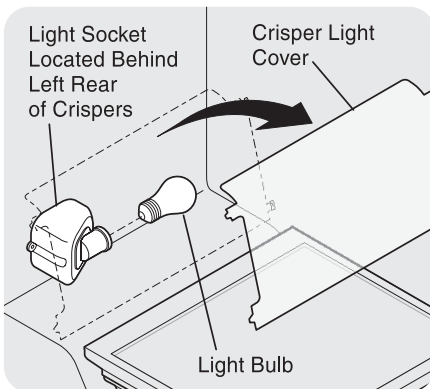

or

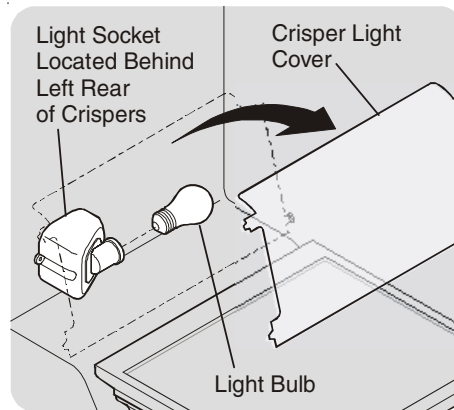

Crisper Light Replacement (Models may vary)

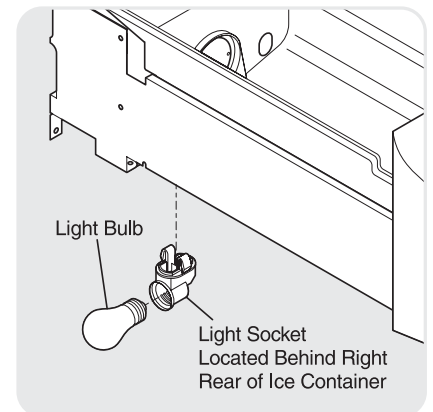

Freezer Light Replacement

Vacation and Moving Tips

Short Vacations	<ul style="list-style-type: none"> • Leave refrigerator operating during vacations of 3 weeks or less. • Use all perishable items from refrigerator compartment. • Turn automatic ice maker off and empty ice bucket, even if you will only be gone for a few days.
Long Vacations	<ul style="list-style-type: none"> • Remove all food and ice if you will be gone one month or more. • Turn off automatic ice maker and turn water supply valve to closed position. • The On/Off button on the Electronic Control only controls your refrigerator's cooling system. To turn off power to your refrigerator you must unplug the power cord from the wall outlet. • Clean interior thoroughly. • Leave both doors open to prevent odors and mold build-up. Block doors open if necessary.
Moving	<ul style="list-style-type: none"> • Remove all food and ice. • If using handcart, load from side. • Adjust rollers all the way up to protect them during sliding or moving. • Pad cabinet to avoid scratching surface.

IMPORTANT

If the refrigerator is going to be stored or moved in freezing temperatures, the water in the ice and water system must be drained completely. Failure to do so could result in water leaks when the refrigerator is put back into service. Contact a service representative to perform this operation.



Major Appliance Warranty Information

Your appliance is covered by a one year limited warranty. For one year from your original date of purchase, Electrolux will pay all costs for repairing or replacing any parts of this appliance that prove to be defective in materials or workmanship when such appliance is installed, used and maintained in accordance with the provided instructions.

Exclusions **This warranty does not cover the following:**

1. Products with original serial numbers that have been removed, altered or cannot be readily determined.
2. Product that has been transferred from its original owner to another party or removed outside the USA or Canada.
3. Rust on the interior or exterior of the unit.
4. Products purchased "as-is" are not covered by this warranty.
5. Food loss due to any refrigerator or freezer failures.
6. Products used in a commercial setting.
7. Service calls which do not involve malfunction or defects in materials or workmanship, or for appliances not in ordinary household use or used other than in accordance with the provided instructions.
8. Service calls to correct the installation of your appliance or to instruct you how to use your appliance.
9. Expenses for making the appliance accessible for servicing, such as removal of trim, cupboards, shelves, etc., which are not a part of the appliance when it is shipped from the factory.
10. Service calls to repair or replace appliance light bulbs, air filters, water filters, other consumables, or knobs, handles, or other cosmetic parts.
11. Surcharges including, but not limited to, any after hour, weekend, or holiday service calls, tolls, ferry trip charges, or mileage expense for service calls to remote areas, including the state of Alaska.
12. Damages to the finish of appliance or home incurred during installation, including but not limited to floors, cabinets, walls, etc.
13. Damages caused by: services performed by unauthorized service companies; use of parts other than genuine Electrolux parts or parts obtained from persons other than authorized service companies; or external causes such as abuse, misuse, inadequate power supply, accidents, fires, or acts of God.

DISCLAIMER OF IMPLIED WARRANTIES; LIMITATION OF REMEDIES

CUSTOMER'S SOLE AND EXCLUSIVE REMEDY UNDER THIS LIMITED WARRANTY SHALL BE PRODUCT REPAIR OR REPLACEMENT AS PROVIDED HEREIN. CLAIMS BASED ON IMPLIED WARRANTIES, INCLUDING WARRANTIES OF MERCHANTABILITY OR FITNESS FOR A PARTICULAR PURPOSE, ARE LIMITED TO ONE YEAR OR THE SHORTEST PERIOD ALLOWED BY LAW, BUT NOT LESS THAN ONE YEAR. ELECTROLUX SHALL NOT BE LIABLE FOR CONSEQUENTIAL OR INCIDENTAL DAMAGES SUCH AS PROPERTY DAMAGE AND INCIDENTAL EXPENSES RESULTING FROM ANY BREACH OF THIS WRITTEN LIMITED WARRANTY OR ANY IMPLIED WARRANTY. SOME STATES AND PROVINCES DO NOT ALLOW THE EXCLUSION OR LIMITATION OF INCIDENTAL OR CONSEQUENTIAL DAMAGES, OR LIMITATIONS ON THE DURATION OF IMPLIED WARRANTIES, SO THESE LIMITATIONS OR EXCLUSIONS MAY NOT APPLY TO YOU. THIS WRITTEN WARRANTY GIVES YOU SPECIFIC LEGAL RIGHTS. YOU MAY ALSO HAVE OTHER RIGHTS THAT VARY FROM STATE TO STATE.

If You Need Service Keep your receipt, delivery slip, or some other appropriate payment record to establish the warranty period should service be required. If service is performed, it is in your best interest to obtain and keep all receipts. Service under this warranty must be obtained by contacting Electrolux at the addresses or phone numbers below.

This warranty only applies in the USA and Canada. In the USA, your appliance is warranted by Electrolux Major Appliances North America, a division of Electrolux Home Products, Inc. In Canada, your appliance is warranted by Electrolux Canada Corp. Electrolux authorizes no person to change or add to any obligations under this warranty. Obligations for service and parts under this warranty must be performed by Electrolux or an authorized service company. Product features or specifications as described or illustrated are subject to change without notice.

USA
1.800.944.9044
Electrolux Major Appliances
North America
P.O. Box 212378
Augusta, GA 30907



Canada
1.800.668.4606
Electrolux Canada Corp.
5855 Terry Fox Way
Mississauga, Ontario, Canada
L5V 3E4



BEFORE YOU CALL

1-800-944-9044 (United States)

1-800-265-8352 (Canada)

Visit our web site at
www.frigidaire.com.

PROBLEM	CAUSE	CORRECTION
RUNNING OF REFRIGERATOR		
Compressor does not run.	<ul style="list-style-type: none"> Freezer control is set to "OF". Refrigerator is in defrost cycle. Plug at wall outlet is disconnected. House fuse blown or tripped circuit breaker. Power outage. 	<ul style="list-style-type: none"> Set freezer control. See Temperature Controls section. This is normal for a fully automatic defrost refrigerator. The defrost cycle occurs periodically, lasting about 30 minutes. Ensure plug is tightly pushed into outlet. Check/replace fuse with a 15 amp time-delay fuse. Reset circuit breaker. Check house lights. Call local Electric Company.
Refrigerator runs too much or too long.	<ul style="list-style-type: none"> Room or outside weather is hot. Refrigerator has recently been disconnected for a period of time. Automatic ice maker is operating. Doors are opened too frequently or too long. Refrigerator/freezer door may be slightly open. Freezer control is set too cold (control found in refrigerator section). Refrigerator/freezer gasket is dirty, worn, cracked, or poorly fitted. Condenser is dirty. 	<ul style="list-style-type: none"> It's normal for the refrigerator to work longer under these conditions. It takes 8-12 hours for the refrigerator to cool down completely. Ice maker operation causes refrigerator to run slightly more. Warm air entering the refrigerator causes it to run more. Open doors less often. Ensure refrigerator is level. Keep food and containers from blocking door. See PROBLEM section OPENING/CLOSING OF DOORS/DRAWERS. Set refrigerator control to warmer setting until refrigerator temperature is satisfactory. Allow 24 hours for temperature to stabilize. Clean or change gasket. Leaks in door seal will cause refrigerator to run longer in order to maintain desired temperatures. Clean condenser. See <i>Care & Cleaning Chart</i> in Care and Cleaning section.
Compressor goes off and on frequently.	<ul style="list-style-type: none"> Thermostat keeps the refrigerator at a constant temperature. 	<ul style="list-style-type: none"> This is normal. Refrigerator goes on and off to keep temperature constant.
TEMPERATURES ARE TOO COLD		
Freezer temperature too cold. Refrigerator temperature is satisfactory.	<ul style="list-style-type: none"> Freezer control is set too cold. 	<ul style="list-style-type: none"> Set freezer control to a warmer setting. Allow 24 hours for temperature to stabilize.
Refrigerator temperature too cold. Freezer temperature is satisfactory.	<ul style="list-style-type: none"> Refrigerator control is set too cold. 	<ul style="list-style-type: none"> Set refrigerator control to a warmer setting. Allow 24 hours for temperature to stabilize.
Food stored in drawers freezes.	<ul style="list-style-type: none"> Refrigerator control is set too cold. 	<ul style="list-style-type: none"> See solution above.
Food stored in Meat Keeper freezes (some models).	<ul style="list-style-type: none"> Meat Keeper Temperature Control set too cold. 	<ul style="list-style-type: none"> Adjust Meat Keeper Temperature Control to a lower setting. (Meat should be stored at a temperature just below the freezing point for maximum fresh storage time. It is normal for ice crystals to form due to the moisture content of meat.)
Digital temperature displays are flashing.	<ul style="list-style-type: none"> Electronic control system has detected a performance problem. 	<ul style="list-style-type: none"> Call your Electrolux service representative, who can interpret any messages or number codes flashing on the digital displays.



BEFORE YOU CALL (CONTINUED)

PROBLEM	CAUSE	CORRECTION
TEMPERATURES ARE TOO WARM		
Freezer/Refrigerator temperature is too warm.	<ul style="list-style-type: none"> • Doors are opened too frequently or too long. • Door is slightly open. • Condenser is dirty. 	<ul style="list-style-type: none"> • Warm air enters the refrigerator whenever the door is opened. Open the door less often. • See PROBLEM section OPENING/CLOSING OF DOORS/DRAWERS. • Clean condenser. See <i>Care & Cleaning Chart</i> in Care and Cleaning section.
Freezer temperature is too warm. Refrigerator temperature is satisfactory.	<ul style="list-style-type: none"> • Freezer control is set too warm. 	<ul style="list-style-type: none"> • Set freezer control to a colder setting. Allow 24 hours for temperature to stabilize.
Refrigerator temperature is too warm. Freezer temperature is satisfactory.	<ul style="list-style-type: none"> • Refrigerator control is set too warm. 	<ul style="list-style-type: none"> • Set refrigerator control to a colder setting. Allow 24 hours for temperature to stabilize.
Temperature in the Meat Keeper is too warm (some models).	<ul style="list-style-type: none"> • Meat Keeper Temperature Control is set too warm. 	<ul style="list-style-type: none"> • Adjust Meat Keeper Temperature Control to a colder setting.
WATER/MOISTURE/FROST INSIDE REFRIGERATOR		
Moisture collects on inside of refrigerator walls.	<ul style="list-style-type: none"> • Weather is hot and humid. • Door is slightly open. • Door is opened too often or too long. • Open containers. 	<ul style="list-style-type: none"> • The rate of frost buildup and internal sweating increases. • See PROBLEM section OPENING/CLOSING OF DOORS/DRAWERS. • Open door less often. • Keep containers covered.
Water collects on bottom side of drawer cover.	<ul style="list-style-type: none"> • Vegetables contain and give off moisture. 	<ul style="list-style-type: none"> • It is not unusual to have moisture on the bottom side of the cover. • Move humidity control (some models) to lower setting.
Water collects in bottom of drawer.	<ul style="list-style-type: none"> • Washed vegetables and fruit drain while in the drawer. 	<ul style="list-style-type: none"> • Dry items before putting them in the drawer. Water collecting in bottom of drawer is normal.
WATER/MOISTURE/FROST OUTSIDE REFRIGERATOR		
Moisture collects on outside of refrigerator or between doors.	<ul style="list-style-type: none"> • Weather is humid. • Door is slightly open, causing cold air from inside refrigerator to meet warm air from outside. 	<ul style="list-style-type: none"> • This is normal in humid weather. When humidity is lower, the moisture should disappear. • See PROBLEM section OPENING/CLOSING OF DOORS/DRAWERS.
AUTOMATIC ICE MAKER		
Ice maker is not making any ice.	<ul style="list-style-type: none"> • Ice maker wire signal arm is in the “up” or OFF position. • Ice maker power switch is Off. • Household water line valve is not open. • Freezer is not cold enough. • Saddle valve on cold water pipe is clogged or restricted by foreign material. • Check to see if the water dispenser is dispensing water. 	<ul style="list-style-type: none"> • Move wire signal arm to the “down” or ON position. (side mounted) • Turn power switch to On (“I”) position. (rear mounted) • Turn on household water line valve. • See PROBLEM section TEMPERATURES ARE TOO WARM. • Turn off household water line valve. Remove valve. Ensure that valve is not a self-piercing saddle valve. Clean valve. Replace valve if necessary. • If not, the ice & water filter cartridge is clogged or restricted by foreign material, and must be replaced.



BEFORE YOU CALL (CONTINUED)

PROBLEM	CAUSE	CORRECTION
AUTOMATIC ICE MAKER (CONTINUED)		
Ice maker is not making enough ice.	<ul style="list-style-type: none"> • Ice maker is producing less ice than you expect. • Freezer is not cold enough. • Household water line valve is not completely open. • Check to see if water dispenser is dispensing slower than normal. 	<ul style="list-style-type: none"> • Ice maker should produce approximately 4 – 5 pounds of ice every 24 hours. <i>Extra Ice</i> should produce up to 8 pounds of ice every 24 hours. • See PROBLEM section TEMPERATURES ARE TOO WARM. • Turn on household water line valve. • If it is, replace the ice & water filter cartridge.
Ice maker will not stop making ice.	<ul style="list-style-type: none"> • Ice maker wire signal arm is being held down by some item in the freezer. 	<ul style="list-style-type: none"> • Move item and release wire signal arm. Remove any ice cubes that are frozen together over the wire signal arm.
Ice maker is not separating the ice cubes.	<ul style="list-style-type: none"> • Ice cubes are not being used frequently enough. • Ice cubes are hollow or smaller than normal. 	<ul style="list-style-type: none"> • Remove and shake ice container to separate cubes. • The ice & water filter cartridge may be clogged. Replace filter cartridge.
Ice has bad odor and taste.	<ul style="list-style-type: none"> • Ice has picked up odor or flavor from strong food stored in refrigerator or freezer. • Water running to ice maker has poor taste or odor. • Ice not used frequently enough. 	<ul style="list-style-type: none"> • Cover foods tightly. Discard stale ice. Ice maker will produce fresh supply. • Add filter to water supply line. Consult a water purifying company. • Discard stale ice.
ICE DISPENSER		
Dispenser will not dispense ice.	<ul style="list-style-type: none"> • Ice storage container is empty. • Freezer temperature is set too warm. • Household water line valve is not open. • Freezer door is not closed. • Ice dispensing arm has been held in for more than 4-5 minutes. 	<ul style="list-style-type: none"> • When the first supply of ice is dropped into the container, the dispenser should operate. • Turn freezer control to a higher setting so that ice cubes will be made. When first supply of ice is made, dispenser should operate. • Open household water line valve. Allow sufficient time for the ice to be made. When ice is made, the dispenser should operate. • Ensure freezer door is closed. • Motor is overloaded. Motor overload protector will reset in approximately 3 minutes. Ice can then be dispensed.
Ice dispenser is jammed.	<ul style="list-style-type: none"> • Ice has melted and frozen around auger due to infrequent use, temperature fluctuations, and/or power outages. • Ice cubes are jammed between ice maker and back of ice container. • Ice cubes are frozen together. • Ice cubes are hollow or smaller than normal. 	<ul style="list-style-type: none"> • Remove ice container, thaw, and empty the contents. Clean container, wipe dry, and replace in proper position. When new ice is made, dispenser should operate. • Remove ice cubes that are jamming the dispenser. • Use the dispenser often so that cubes do not freeze together. • The ice & water filter cartridge could be clogged. Replace the filter cartridge. Dispensing system operates best at 30 – 100 psi water pressure. Well water pressures should fall within this range.



BEFORE YOU CALL

PROBLEM	CAUSE	CORRECTION
WATER DISPENSER		
Dispenser will not dispense water.	<ul style="list-style-type: none"> Household water line valve is not open. Freezer door is not closed. Ice & water filter cartridge is clogged. Front filter not fully installed, if equipped 	<ul style="list-style-type: none"> Open household water line valve. See PROBLEM section ICE MAKER IS NOT MAKING ANY ICE. Ensure that freezer door is closed. Replace filter cartridge. Push filter in until you hear a “click”. Filter should be flush with cabinet.
Water has an odd taste and/or odor.	<ul style="list-style-type: none"> Water has been in the tank for a period of time. Unit not properly connected to cold water line. Tubing used in the household water supply and installation may affect water taste and odor. Water has a high mineral content. 	<ul style="list-style-type: none"> Draw and discard 10 – 12 glasses of water to freshen the supply and completely rinse out the tank. Connect unit to cold water line that supplies water to the kitchen faucet. For best results, use copper tubing for water connections. Contact water treatment plant for help.
Water pressure is extremely low.	<ul style="list-style-type: none"> Cut-off and cut-on pressures are too low (well systems only). Reverse osmosis system is in regenerative phase. 	<ul style="list-style-type: none"> Have someone turn up the cut-off and cut-on pressure on the water pump system (well systems only). It is normal for a reverse osmosis system to be below 20 psi during the regenerative phase.
ODORS IN REFRIGERATOR		
Interior is dirty.	<ul style="list-style-type: none"> Interior needs to be cleaned. Food with strong odors is in refrigerator. 	<ul style="list-style-type: none"> See <i>Care & Cleaning Chart</i> in Care and Cleaning section. Cover food tightly.
OPENING/CLOSING OF DOORS/DRAWERS		
Door(s) will not close.	<ul style="list-style-type: none"> Door was closed too hard, causing other door to open slightly. Refrigerator is not level. It rocks on the floor when moved slightly. Refrigerator is touching a wall or cabinet. 	<ul style="list-style-type: none"> Close both doors gently. Ensure floor is level and solid, and can adequately support the refrigerator. Contact a carpenter to correct a sagging or sloping floor. Ensure floor is level and solid, and can adequately support the refrigerator. Contact a carpenter to correct a sagging or sloping floor.
Drawers are difficult to move.	<ul style="list-style-type: none"> Food is touching shelf on top of drawer. Track that drawers slide on is dirty. 	<ul style="list-style-type: none"> Keep less food in drawer. Clean drawer, rollers, and track. See <i>Care & Cleaning Chart</i> in Care and Cleaning section.
LIGHT BULB IS NOT ON		
Light bulb is not on.	<ul style="list-style-type: none"> Light bulb is burned out. Light switch is stuck. No electric current is reaching refrigerator. 	<ul style="list-style-type: none"> See <i>Replacing Light Bulbs</i> in Care and Cleaning section. Light switch is located on side of refrigerator and freezer liners. See PROBLEM section RUNNING OF REFRIGERATOR.
IF YOU HEAR		
5 beeps	<ul style="list-style-type: none"> A door has been left open for 5 minutes or more. 	<ul style="list-style-type: none"> These beeps will repeat once every minute until the door has been closed. This is normal for the “Door Ajar” alarm.
3 beeps	<ul style="list-style-type: none"> The refrigerator has experienced a loss of power or a low voltage condition. 	<ul style="list-style-type: none"> This is normal when “Power-On-Reset” is activated.