

This Owner's Manual is provided and hosted by [Appliance Factory Parts](#).



MASTERBUILT 20042011 Owner's Manual

[Shop genuine replacement parts for MASTERBUILT
20042011](#)



[Find Your MASTERBUILT Grill Parts - Select From 589 Models](#)

----- Manual continues below -----



Masterbuilt Manufacturing, Inc.
 1 Masterbuilt Court
 Columbus, Georgia 31907
 Customer Service 1-800-489-1581



ASSEMBLY, CARE & USE MANUAL
WARNING & SAFETY INFORMATION
MODEL 20042111 CLASSIC BARREL GRILL WITH FIREBOX
THIS PRODUCT IS FOR OUTDOOR USE ONLY

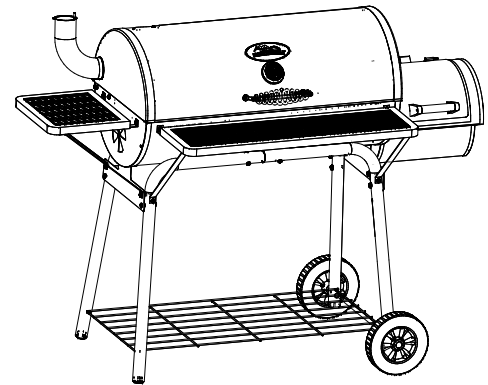

Manual Code: 9804100053 083010-04SS

Tools required for assembly: Adjustable Wrench, Phillips Head Screwdriver.

⚠ CARBON MONOXIDE HAZARD ⚠	⚠ WARNING ⚠
<p>Burning charcoal gives off carbon monoxide, which has no odor and can cause death.</p> <p>DO NOT burn charcoal inside homes, vehicles, tents, garages or any enclosed areas.</p> <p>Use only outdoors where it is well ventilated.</p>	<p>This manual contains important information necessary for the proper and safe use of this grill.</p> <p>Read and follow all warnings and instructions before using grill and during use.</p> <p>Keep it for future reference.</p>
<p>Failure to follow these warnings and instructions properly could result in fire or explosion, which could cause property damage, personal injury, or death.</p>	

GENERAL WARNING AND SAFETY INFORMATION

- Keep a fire extinguisher accessible at all times while operating grill.
- Never leave grill unattended while in use.
- Never use inside an enclosed area such as a patio, garage, building or tent.
- Never use inside a vehicle, not even a recreational vehicle such as a motorhome, camper, or truck bed.
- Never operate this grill under any overhead construction such as roof coverings, carports, awnings or overhangs.
- Maintain a minimum distance of 10 ft. (3m) from all structures.
- Keep area clear of all combustible materials such as wood, dry plants, grass, brush, paper or canvas.
- Never operate this grill within 25 ft. (7.5m) of flammable liquids.
- Never operate this grill within 10 ft. (3m) of a gas cylinder.
- Never use this grill as a heater (READ CARBON MONOXIDE HAZARD).
- Use this grill only on a stable, level surface to prevent tipping.
- Use on non-combustible surfaces such as dirt, concrete, brick or rock.
- Keep children and pets away from grill at all times. Do not allow children to use grill.
- Only use charcoal lighting fluid. Never use gasoline, alcohol or other highly volatile fluids to ignite charcoal. These fluids can explode causing injury or death.
- Grill is HOT while in use and will remain HOT for a period of time afterwards. Do not touch any part of the grill without wearing protective gloves.
- Never move grill when in use. Allow grill to cool completely before moving or storing.
- Never leave HOT coals or ashes unattended.
- Do not store grill with HOT ashes or charcoal inside grill. Store only when fire is completely out and all surfaces are cold.
- Dispose of cold ashes by placing them in aluminum foil, soaking with water and discarding in a non-combustible container.
- Accessory attachments not supplied by Masterbuilt Outdoor Products® are not recommended.
- Never use this product for anything other than its intended purpose. This grill is not for commercial use.
- Always use this grill in accordance with all applicable local, state and federal fire codes.

WARNING

Combustion by-product produced when using this product contains chemicals known to the State of California to cause birth defects, other reproductive harm, or cancer.

The materials used in this product may contain lead a chemical known to the State of California to cause birth defects and other reproductive harm.

LIMITED WARRANTY INFORMATION

Masterbuilt warrants its products to be free from defects in material and workmanship under proper assembly, normal use and recommended care for 90 days from the date of original retail purchase. Masterbuilt warranty does not cover paint finish as it may burn off during normal use. Masterbuilt warranty does not cover rust of the unit. Masterbuilt requires reasonable proof of purchase for warranty claims and suggests that you keep your receipt. Upon the expiration of such warranty, all such liability shall terminate. Within the stated warranty period, Masterbuilt, at its discretion, shall repair or replace defective components free of charge with owner being responsible for shipping. Should Masterbuilt require return of component(s) in question for inspection Masterbuilt will be responsible for shipping charges to return requested item. This warranty excludes property damage sustained due to misuse, abuse, accident, damage arising out of transportation, or damage incurred by commercial use of this product.

This expressed warranty is the sole warranty given by Masterbuilt and is in lieu of all other warranties, expressed or implied including implied warranty, merchantability, or fitness for a particular purpose. Neither Masterbuilt nor the retail establishment selling this product, has authority to make any warranties or to promise remedies in addition to or inconsistent with those stated above. Masterbuilt's maximum liability, in any event, shall not exceed the purchase price of the product paid by the original consumer/ purchaser. Some states do not allow the exclusion or limitation of incidental or consequential damages. In such a case, the above limitations or exclusions may not be applicable.

California residents only: Notwithstanding this limitation of warranty, the following specific restrictions apply: if service, repair, or replacement of the product is not commercially practical, the retailer selling the product or Masterbuilt will refund the purchase price paid for the product, less the amount directly attributable to use by the original buyer prior to the discovery of the nonconformity. Owner may take the product to the retail establishment selling this product in order to obtain performance under warranty. This expressed warranty gives you specific legal rights, and you may also have other rights which vary from state to state.

Go Online www.masterbuilt.com
or complete and return to
Attn: Warranty Registration
Masterbuilt Mfg. Inc.
1 Masterbuilt Court - Columbus, GA 31907

Name: _____

Address: _____

City, State/Province, Postal Code: _____

Phone Number: _____ E-Mail Address: _____

Model Number: _____ Serial Number: _____

Purchase Date: _____ Place of Purchase: _____

APPROXIMATE GRILLING TIMES

BEEF	SIZE	GRILLING TIME	INTERNAL TEMP
Steaks	¾" (2cm) thick	3 to 4 min. /side	med rare 145°F (62°C)
		4 to 5 min. /side	med 160°F (71°C)
Kabobs	1" (2.5cm) cubes	3 to 4 min. /side	145°-160°F (62-71°C)
Hamburger patties	½" (12mm) thick	3 to 4 min. /side	med 160°F (71°C)
Roast, rolled rump	4-6 lbs. (1.8-2.7kg)	18 to 22 min /lb.	145°-160°F (62-71°C)
Sirloin tip	3 ½-4 lbs. (1.5-1.8kg)	20 to 25 min. /lb.	145°-160°F (62-71°C)
Ribs, back	cut in 1-rib portions	10 min. /side	med 160°F (71°C)
	half, 2-3 lbs. (0.9-1.3kg)	10 to 12 min. /side	med rare 145°F (62°C)
Tenderloin	whole, 4-6 lbs. (1.8-2.7kg)	12 to 15 min. /side	med 160°F (71°C)
PORK	SIZE	GRILLING TIME	INTERNAL TEMP
Chops, bone-in	¾" (2cm) thick	3 to 4 min. /side	med 160°F (71°C)
Chops, bone-out	1 ½" (4cm) thick	7 to 8 min. /side	med 160°F (71°C)
Tenderloin	½-1 ½ lbs. (0.2-0.6kg)	15 to 25 min. total	med 160°F (71°C)
Ribs (indirect heat)	2-4 lbs. (0.9-1.8kg)	1 1/2 to 2 hrs.	med 160°F (71°C)
VENISON	SIZE	GRILLING TIME	INTERNAL TEMP
Roast, saddle or leg	6-7 lbs. (2.7-3.1kg)	25 to 30 min. /lb.	145°-160°F (62-71°C)
Steaks	¾" (2cm) thick	6 to 7 min. /side	med 160°F (71°C)
CHICKEN	SIZE	GRILLING TIME	INTERNAL TEMP
Broiler fryer (indirect heat)	3-4 lbs. (1.3-1.8kg)	60 to 75 min.	in thigh 180°F (82°C)
Cornish hens	18-24 oz. (510-680g)	45 to 55 min.	in thigh 180°F (82°C)
Breast halves, bone-in	6-8 oz. (170-226g) each	10 to 15 min. /side	170°F (77°C)
Breast halves, boneless	4 oz. (113g) each	6 to 8 min. /side	170°F (77°C)
Legs or thighs	4-8 oz. (113-226g)	10 to 15 min. /side	180°F (82°C)
Drumsticks	4 oz. (113g)	8 to 12 min. /side	180°F (82°C)
Wings	2-3 oz. (56-85g)	8 to 12 min. /side	180°F (82°C)

* When outside temperature is cooler than 65°F (18°C) and/or altitude is above 3,500 ft. (1067m), additional cooking time may be required. To insure that meat is completely cooked use a meat thermometer to test internal temperature.

• Lifting grill lid during cooking process may extend cooking time due to heat loss.

PARTS LIST

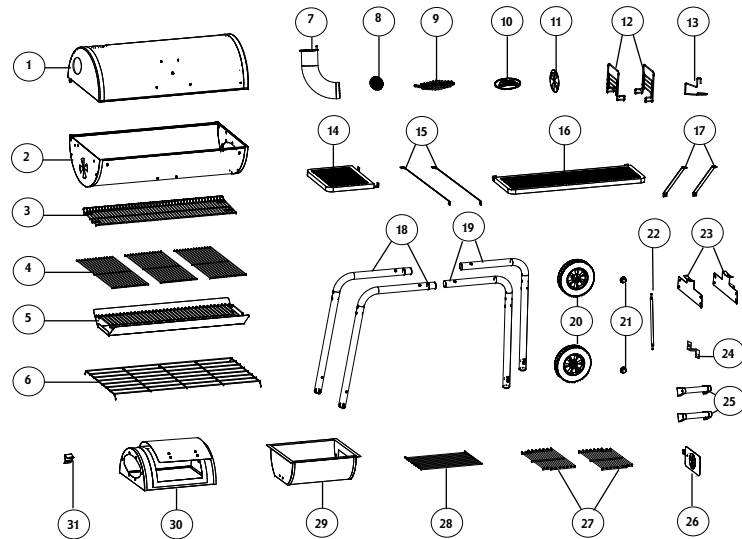

ITEM NO.	QUANTITY	DESCRIPTION	ITEM NO.	QUANTITY	DESCRIPTION
1	1	Grill Lid	16	1	Front Shelf
2	1	Grill Body	17	2	Front Shelf Bracket
3	1	Warming Rack	18	2	Left Long Leg
4	3	Cooking Grate	19	2	Right Short Leg
5	1	Charcoal Pan	20	2	Wheel
6	1	Storage Shelf	21	2	Axle Cap
7	1	Smoke Stack	22	1	Axle
8	1	Temperature Gauge	23	2	Leg Bracket
9	1	Grill Body Lid Handle	24	1	Firebox Box Bracket
10	1	Logo Plate	25	2	Firebox Box Handle
11	1	Air Damper	26	1	Firebox Box Charcoal Access Door
12	2	Charcoal Pan Lifter	27	2	Firebox Box Cooking Grate
13	1	Grease Clip	28	1	Firebox Box Charcoal Grate
14	1	Side Shelf	29	1	Firebox Box Bottom
15	2	Side Shelf Bracket	30	1	Firebox Box Top (Pre-assembled)
			31	1	Lid Stop

HARDWARE LIST

BLISTER PACK CONTENTS



(A)
M6x12
Phillips Head Screw
qty-41

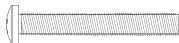

(B)
M6x45
Phillips Head Screw
qty-14

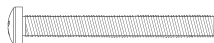

(C)
M6x70
Phillips Head Screw
qty-2



(D)
M6
Hex Flange Nut
qty-37



(E)
M6
Lock Nut
qty-5

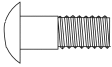

(F)
M6
Carriage Bolt
qty-2



(G)
M6
Flat Washer
qty-2



(H)
M6
Lock Washer
qty-2



(I)
Cotter Clip
qty-2

PRE-PACKED HARDWARE



(J)
M5 Hex Nut
qty-2



(L)
M5 Lock Washer
qty-2

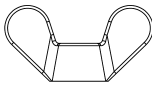

(K)
Wing Nut
(packed with temperature gauge)
qty-1

CHARCOAL LIGHTING INSTRUCTIONS

Read all instructions and warnings on charcoal bag and in manual before using.

- Stack briquets in a pyramid.
 - Add lighter fluid following directions on fluid container. Before lighting, place lighter fluid at least 25 ft. (7.5m) away from grill. Do not lean over grill when lighting charcoal. Light charcoal. LEAVE GRILL UNCOVERED.
 - In about 15 minutes, flames will die out and briquets will begin to ash over. Once the briquets are completely ashed over, spread briquets in a single layer and begin cooking.
- NEVER USE GASOLINE TO LIGHT CHARCOAL.
 - OVERFILLING CHARCOAL PAN CAN CAUSE SERIOUS INJURY AND DAMAGE THE UNIT.
 - NEVER ADD ADDITIONAL LIGHTER FLUID ONCE CHARCOAL HAS IGNITED.
 - HOT COALS SHOULD NOT BE LEFT UNATTENDED.
 - GRILL IS HOT. USE PROTECTIVE GLOVES AND LONG, STURDY COOKING UTENSILS.

TO ENSURE THAT IT IS SAFE TO EAT, FOOD MUST BE COOKED TO THE MINIMUM INTERNAL TEMPERATURES LISTED IN THE TABLE BELOW.

USDA* Safe Minimum Internal Temperatures	
Fish	145°F (63°C)
Pork	160°F (71°C)
Egg Dishes	160°F (71°C)
Steaks and Roasts of Beef, Veal or Lamb	145°F (63°C)
Ground Beef, Veal or Lamb	160°F (71°C)
Whole Poultry (Turkey, Chicken, Duck, etc.)	165°F (74°C)
Ground or Pieces Poultry (Chicken Breast, etc.)	165°F (74°C)

* United States Department of Agriculture

GRILL OPERATION CAUTIONS

- Avoid bumping or impacting grill.
- Keep your hands, hair and face away from burning charcoal.
- This grill has an open flame. Be careful of loose hair and clothing during operation. They may catch fire.
- Use protective gloves when handling this grill or working with fire. Use protective gloves or long, sturdy fireplace tools when adding wood or charcoal.
- Do not allow anyone to conduct activities around this grill during or following its use until the unit has cooled. This grill is HOT during operation and remains HOT for a period of time following its use.
- Fatty foods like hamburgers can have excess grease that can cause flare ups. When cooking fatty foods, use caution when opening lid and during cooking to avoid being burned.
- Be careful when removing food from grill. All surfaces are HOT and may cause burns. Use protective gloves or long, sturdy cooking tools.
- Never use glass, plastic or ceramic cookware on this grill.
- The use of alcohol, prescription or non-prescription drugs may impair the user's ability to properly assemble or safely operate this grill.
- Grill lid and body are HOT while in use and during cooling process.
- Do not remove adjustable charcoal pan while ashes and charcoal are HOT.
- Air dampers are HOT while the grill is in use and during cooling; wear protective gloves when adjusting.
- Never overfill charcoal pan. This can cause serious injury as well as damage the unit.
- Only use charcoal lighting fluid, never use gasoline, alcohol or other highly volatile fluids to ignite the charcoal. These fluids can explode causing injury or death.

REMINDER: NEVER OPERATE THIS GRILL UNDER ANY OVERHEAD CONSTRUCTION. MAINTAIN A MINIMUM DISTANCE OF 10 FEET FROM OVERHEAD CONSTRUCTION, WALLS OR RAILS. SEE DIAGRAM BELOW.

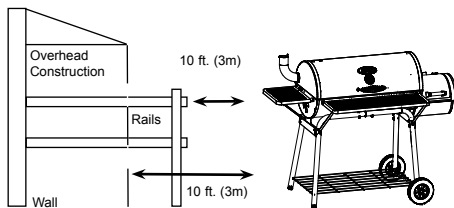

REPLACEMENT PARTS LIST



DO NOT RETURN TO RETAILER
For Assembly Assistance, Missing or Damaged Parts
Call: MASTERBUILT Customer Service at 1-800-489-1581

ITEM NO.	DESCRIPTION
9904100027	Lid Kit
9904100028	Grill Body Kit
9904100029	Smoke Stack Kit
9904090086	Side Shelf Kit
9904090074	Front Shelf Kit
9904090075	Axle Leg Kit
9904090076	Stationary Leg Kit
9904090090	Leg Bracket Kit
9904100030	Firebox Box Bracket Kit
9904090101	Side Shelf Support Kit
9904090102	Front Shelf Support Kit
9904090091	Axle Kit
990050014	Wheel Kit
9904090079	Warming Rack Kit
9904090029	Lid Handle Kit
990050018	Air Damper Kit
9904090033	Logo Plate Kit
990070057	Knock Out Kit
9904090032	Temperature Gauge Kit
9904100031	Firebox Lid Kit
9904100032	Firebox Base Kit
9904100033	Firebox Lid Handle Kit
9904100034	Firebox Access Door Kit
9904100035	Firebox Air Damper Kit
9004100003	Firebox Cooking Grate
9004100002	Firebox Charcoal Grate
9004090104	Lower Shelf (no Hardware)
906050025	Axle Caps
9004090103	Cooking Grate
906060213	Charcoal Grate
906050011	Charcoal Grate Lifter
906050013	Grease Clip
9904090080	Hardware Bag
9804100053	Instruction Manual - English

ASSEMBLY INSTRUCTIONS

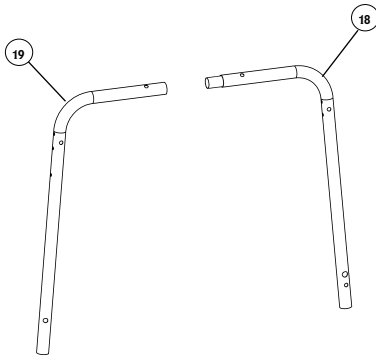

Before assembly read instructions carefully.

This unit is heavy. Do not assemble without assistance.

Tools needed for assembly:
Adjustable Wrench
Phillips Head Screwdriver

Assemble grill on a clean, flat surface.

CAUTION: Use caution during the assembly process.

Some component are heavy.

STEP 1.

Pay close attention to when assembling grill legs. Right legs are shorter to accommodate wheels.

Insert right short leg (18) into left long leg (19) as shown.

Repeat step 1 to assemble second set of legs.

STEP 2. Steps 2-3 require assistance. Get a helper!

Insert storage shelf (6) into holes of assembled grill legs as shown.

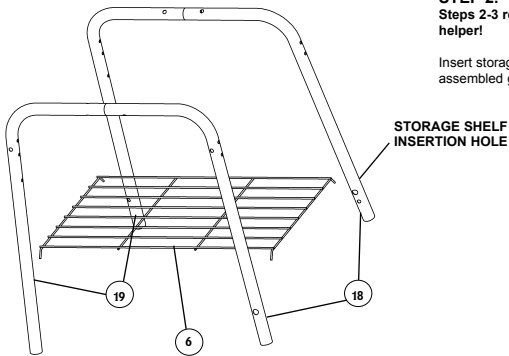

FREQUENTLY ASKED QUESTIONS

Q: The paint finish inside my lid is peeling. What can I do?
A: You are seeing a deposit of grease and smoke that collects during normal use that resembles paint. These carbon deposits are non-toxic, but you may want to regularly remove the build-up. Remove buildup using a brass or stiff bristle brush before grilling. Future build-up can be avoided by simply wiping the grill lid while slightly warm with a mild soap-and-water solution.

Q: When can I put my meat on the grill?
A: Grill is ready for use when charcoal is ashed over and no visible flames are present.

Q: How do I regulate the heat on my grill?
A: Adjusting the dampers will increase and decrease airflow and heating.

SAFE STORAGE AND MAINTENANCE

- Inspect bolt, hex lock nut and hex flange nut tightness on a regular basis to ensure grill is in safe working condition.
- ALWAYS allow grill to cool completely before handling.
- ALWAYS empty charcoal pan after use only when ashes have completely cooled. This will help prolong charcoal pan life.
- Clean grill, including special surfaces such as cooking grates with mild cleaning agents. Wipe outside of grill with damp rag. DO NOT use oven cleaner.
- ALWAYS cover and store cold grill in a protected area.
- Indoor storage of grill is permissible only if the charcoal has burned to a complete ash AND is cold. Remember to remove cold ashes before storing.
- Grill is made of steel and may rust over time. If rusting occurs on outside surfaces, clean area with sand paper or steel wool, then cover with heat resistant paint.
- If rusting occurs on the inside surface of grill, clean area with sandpaper or steel wool, then coat with cooking oil.
- NEVER USE PAINT ON INSIDE SURFACES OF GRILL

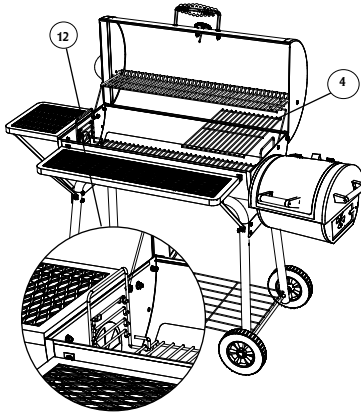

STEP 25.
Position charcoal tray lifter (12) on side supports in grill body as shown. Place cooking grates (4) into grill body.

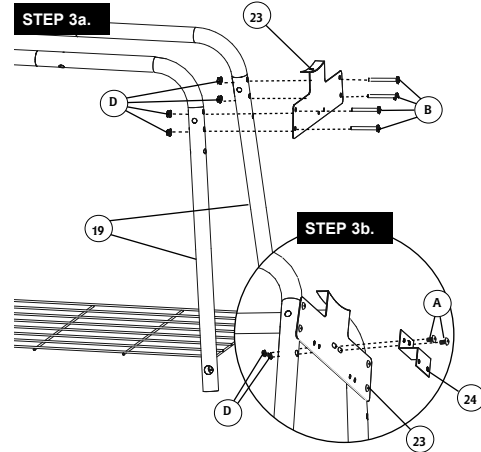

STEP 3a.
Attach leg bracket (23) to right short legs (19) as shown using phillips head screws (B) and hex flange nuts (D).

STEP 3b.
Fasten firebox box bracket (24) to leg bracket (23) securing with phillips head screws (A) and hex flange nuts (D).

Do not fully tighten screws at this time.

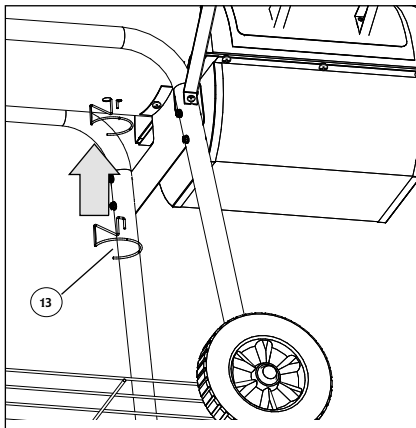

STEP 26.
Insert grease clip (13) up through large hole in bottom of grill body. Engage clip end in small hole.

Position an empty metal container (not included) on grease clip so it rests snugly. The container is needed to collect grease run-off.

Note: Clip may require adjustment to fit diameter of container.

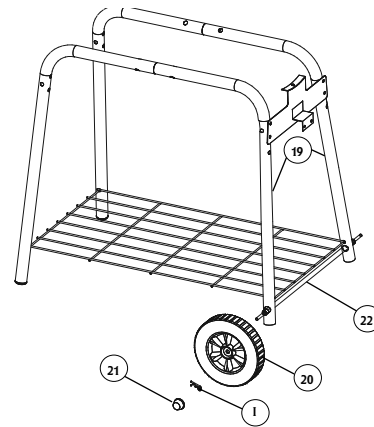

STEP 4.
Insert axle (22) through holes on short right legs (19). Slide wheel (20) onto axle and secure using cotter clip (I). Snap axle cap (21) onto end of wheel assembly as shown.

Repeat step on opposite side for remaining wheel.

Do not fully tighten screws at this time.

GRILL IS READY FOR USE

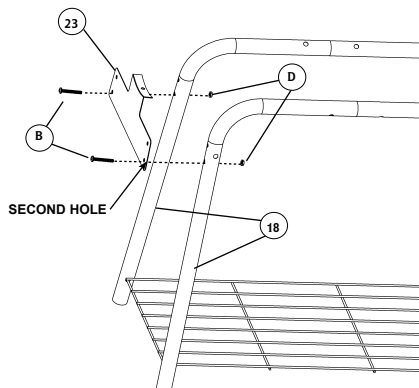

STEP 5.
Note: Attach only using hardware shown.

Use phillips head screws (B) and hex flange nuts (D) on second hole in leg bracket (23) to attach left long leg (18).

Do not attach hardware to first hole. This will be used for side shelf attachment in STEP 9.

Do not fully tighten screws at this time.

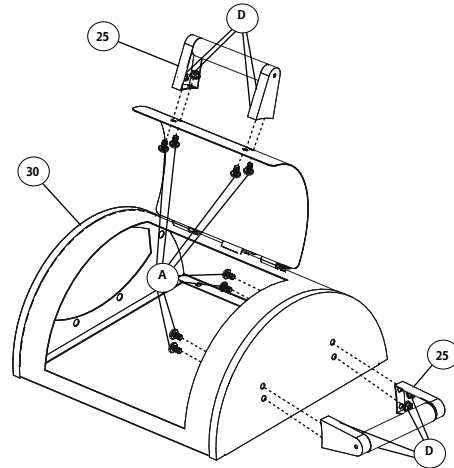

STEP 23.
Some parts not shown for clarity.

Align holes in handle (25) with holes in smoker box lid and side of firebox (30). Secure handle to lid using phillips head screw (A) and hex flange nut (D) as shown.

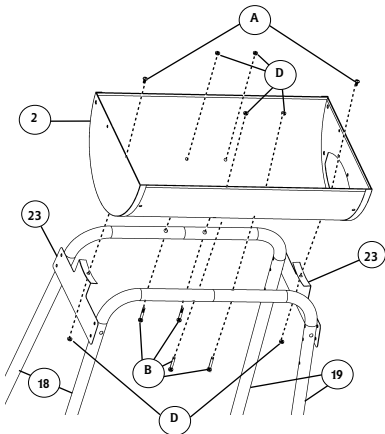

STEP 6.
 Place grill body (2) onto assembled legs with smoker box opening on the same side as the right short legs (19).

Tightly secure grill body to legs using phillips head screws (B), and hex flange nuts (D).

Attach grill body (2) to left leg brackets (23) using phillips head screws (A), and hex flange nuts (D) as shown.

Do not fully tighten screws at this time.

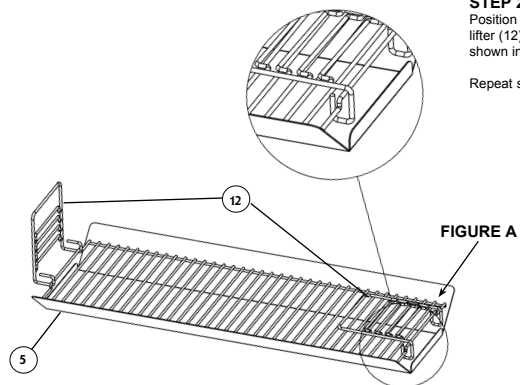

STEP 24.
 Position adjustable charcoal rack lifter (12) on charcoal rack (5) as shown in Figure A.

Repeat step on opposite end.

STEP 21.
 Insert firebox charcoal grate (28) into firebox body as shown.

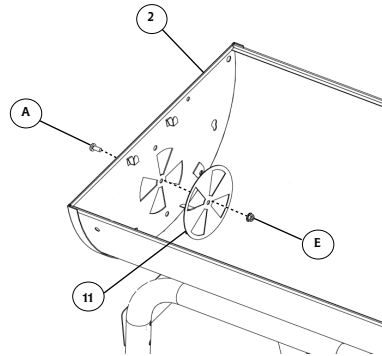
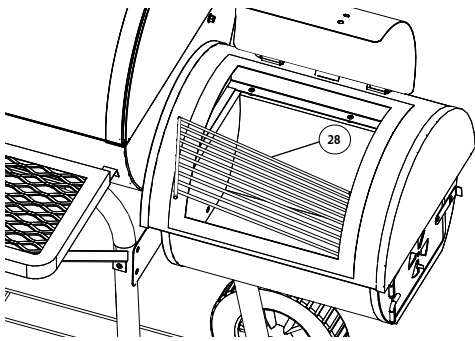

Carefully reposition grill as shown.

STEP 7.
 Note: Do not over tighten. Air damper should move freely.

Attach air damper (11) to body (2) using phillips head screw (A) and lock nut (E) as shown.

STEP 22.
 Note: Shorter end of cooking grate should be placed near corners.

Some parts not shown for clarity.

Insert firebox cooking grates (27) into smoker box as shown.

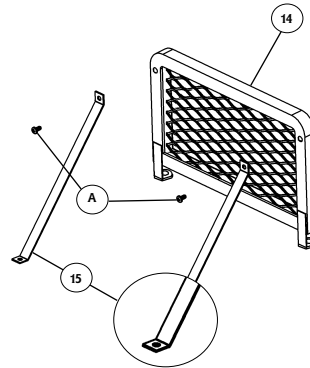
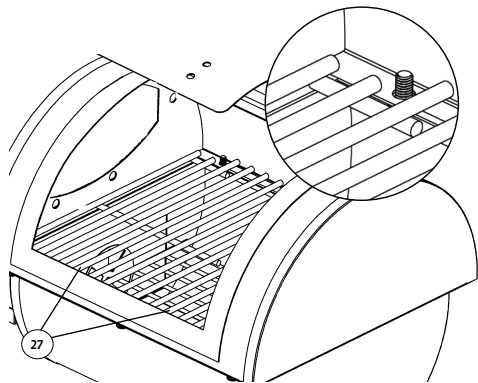

STEP 8.
 Note: Position brackets so sharper angled ends are used to connect to leg bracket.

Attach side shelf support brackets (15) to side shelf (14) using phillips head screws (A).

Do not fully tighten at this time.

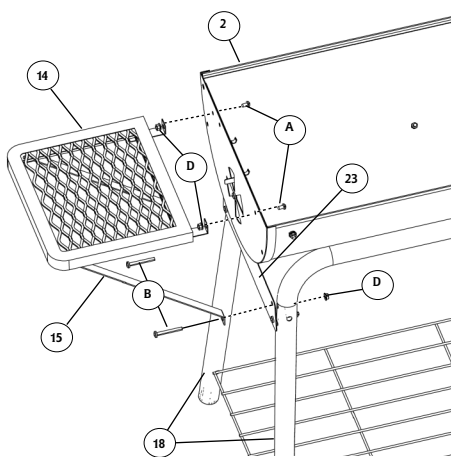

STEP 9.
Align holes on assembled side shelf (14) with holes on grill body (2) and leg bracket (23) as shown.

Insert phillips head screw (A) through holes on body (2) into side shelf (14). Secure using hex flange nuts (D).

Attach shelf support brackets (15) to top holes in leg bracket (23) and left long legs (18) using phillips head screws (B). Secure using hex flange nuts (D).

Do not fully tighten screws at this time.

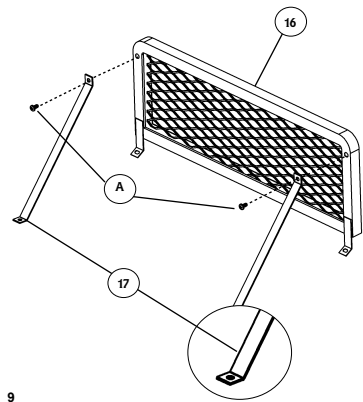

STEP 10.
Attach shelf support brackets (17) to front shelf (16) using phillips head screws (A).

Note: Position brackets so sharper angled ends are used to connect to grill legs.

Do not fully tighten at this time.

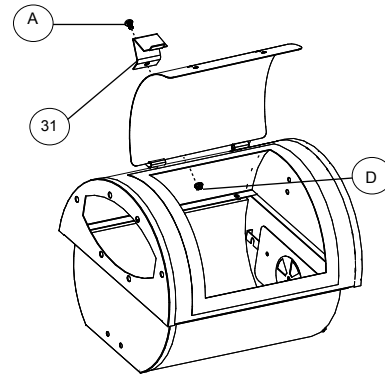

STEP 19.
On rear of firebox, insert tab on lid stop (31) into slot then secure in place with phillips head screw (A) and flange nut (D).

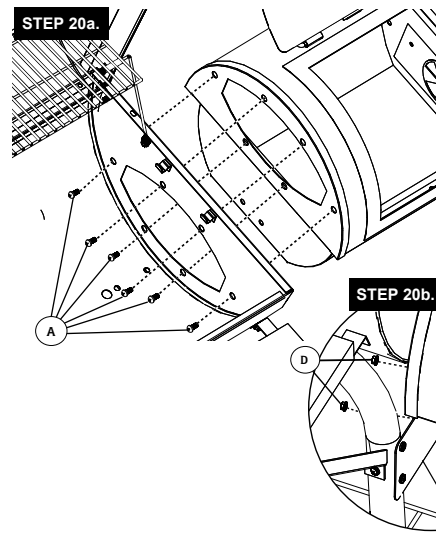

STEP 20a.
Use phillips head screw (A) and to secure firebox to grill body as shown.

STEP 20b.
Complete firebox assembly by aligning holes in smoker box to holes in smoker box bracket (24).

Use phillips head screw (A) and flange nut (D) to secure.

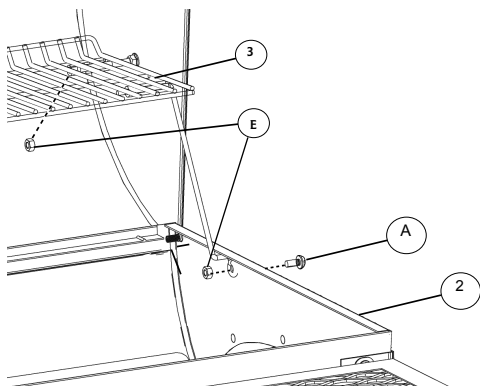

STEP 17.
Secure warming rack (3) to rack support bolt (C) using lock nut (E) as shown.

Note: Be sure not to overtighten lock nut, as rack is to move freely.

Secure warming rack support arm onto grill body (2) using phillips screw (A) and hex lock nut (E).

Repeat step on opposite side.

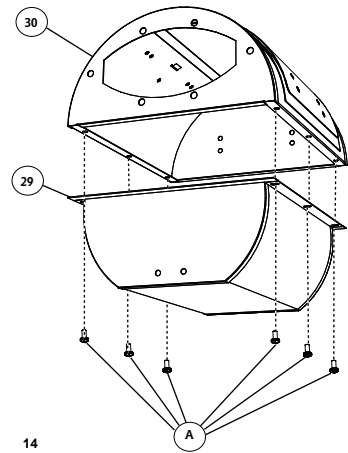

STEP 18.
Place firebox top (30) onto smoker box bottom (29).

Insert phillips head screws (A) through holes in outer lip of firebox as shown. Repeat on opposite side. Tighten securely.

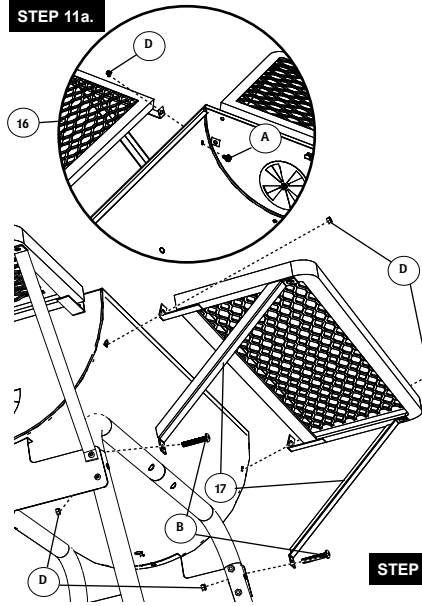

STEP 11a.

STEP 11a.
Align holes on assembled front shelf (16) with holes on grill body (2) as shown.

Insert phillips head screw (A) from inside grill body to front shelf (16). Secure using hex flange nuts (D).

STEP 11b.
Attach shelf support brackets (17) to grill legs using phillips head screws (B). Secure using hex flange nuts (D).

Tighten all hardware at this time.

STEP 11b.

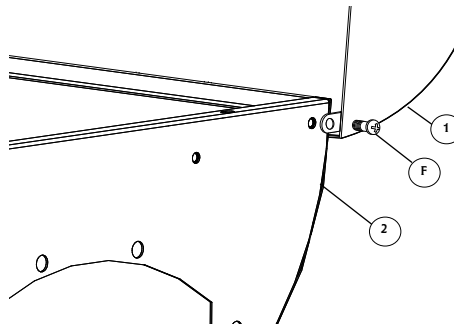

STEP 12.
Step 12 requires assistance. Get a helper!

Align grill lid (1) with grill body (2) as shown. Secure grill lid (1) to grill body (2) using carriage bolt (F).

Repeat step on opposite end.

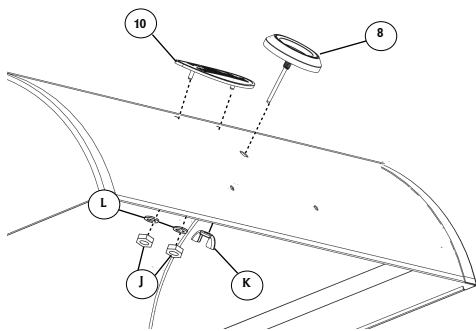

STEP 13a.

Insert temperature gauge (8) stem through hole in grill lid. Secure with wing nut (K).

STEP 13b.

Insert alignment pins on back of logo plate (10) through two holes above temperature gauge (8). Attach using lock washer (L) and hex nut (J) as shown.

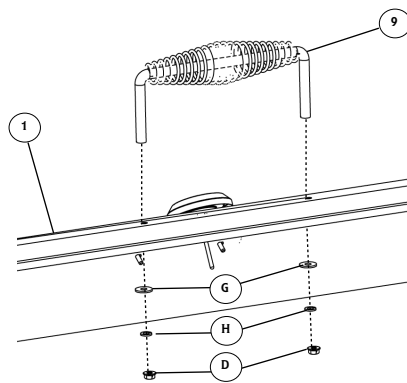

STEP 15.

Secure handle (9) to grill lid (1) using flat washers (G) lock washers (H) and hex flange nuts (D).

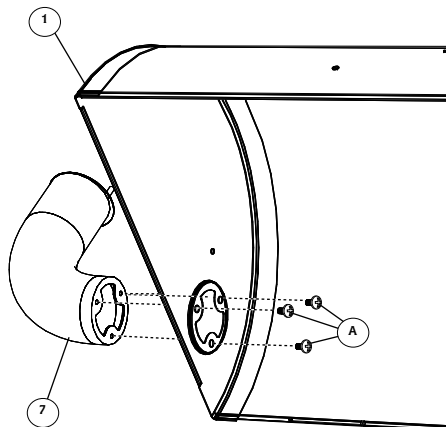

STEP 14.

Attach smoke stack (7) to left side of grill lid (1) and secure with phillips head screws (A) as shown.

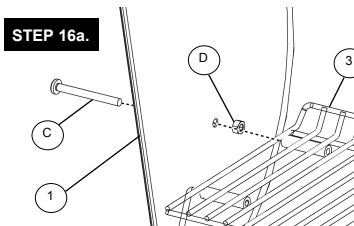

STEP 16a.

STEP 16a.

Insert warming rack support bolt (C) into hole on the left side of grill lid (1). Thread hex flange nut (D) onto bolt and tighten. Slide warming rack (3) eyelet onto end of support bolt.

Note: Warming rack should have some play and move freely.

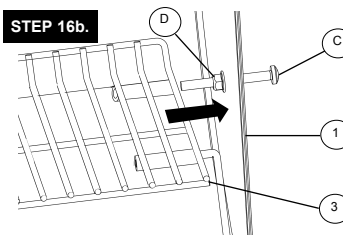

STEP 16b.

STEP 16b.

Slide warming rack to the far left to butt up against grill lid.

On right side of grill lid (1) hold hex flange nut in place with hand and thread rack support bolt (C) through nut, guiding warming rack (3) onto support bolt as shown.