

This Owner's Manual is provided and hosted by [Appliance Factory Parts](#).

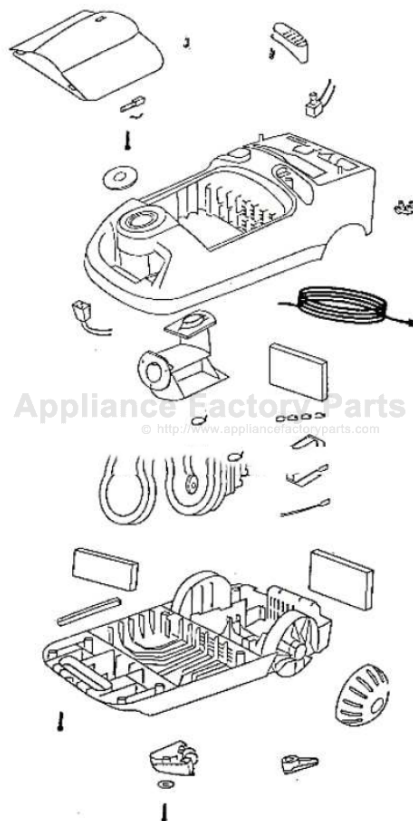

# Eureka 6856A Owner's Manual

[Shop genuine replacement parts for Eureka 6856A](#)



[Find Your Eureka Vacuum Cleaner Parts - Select From 855 Models](#)

----- Manual continues below part list -----

## Available Replacement Parts for Eureka 6856A

<a href="#">E-37657</a>	FILTER, CANISTER, 1PK
<a href="#">ER-2017</a>	BRUSH ROLLER ROLL 54325-1
<a href="#">155506</a>	MOTOR
<a href="#">195-9488</a>	14 INCH WIRE DOLLY - 4 SOCKET

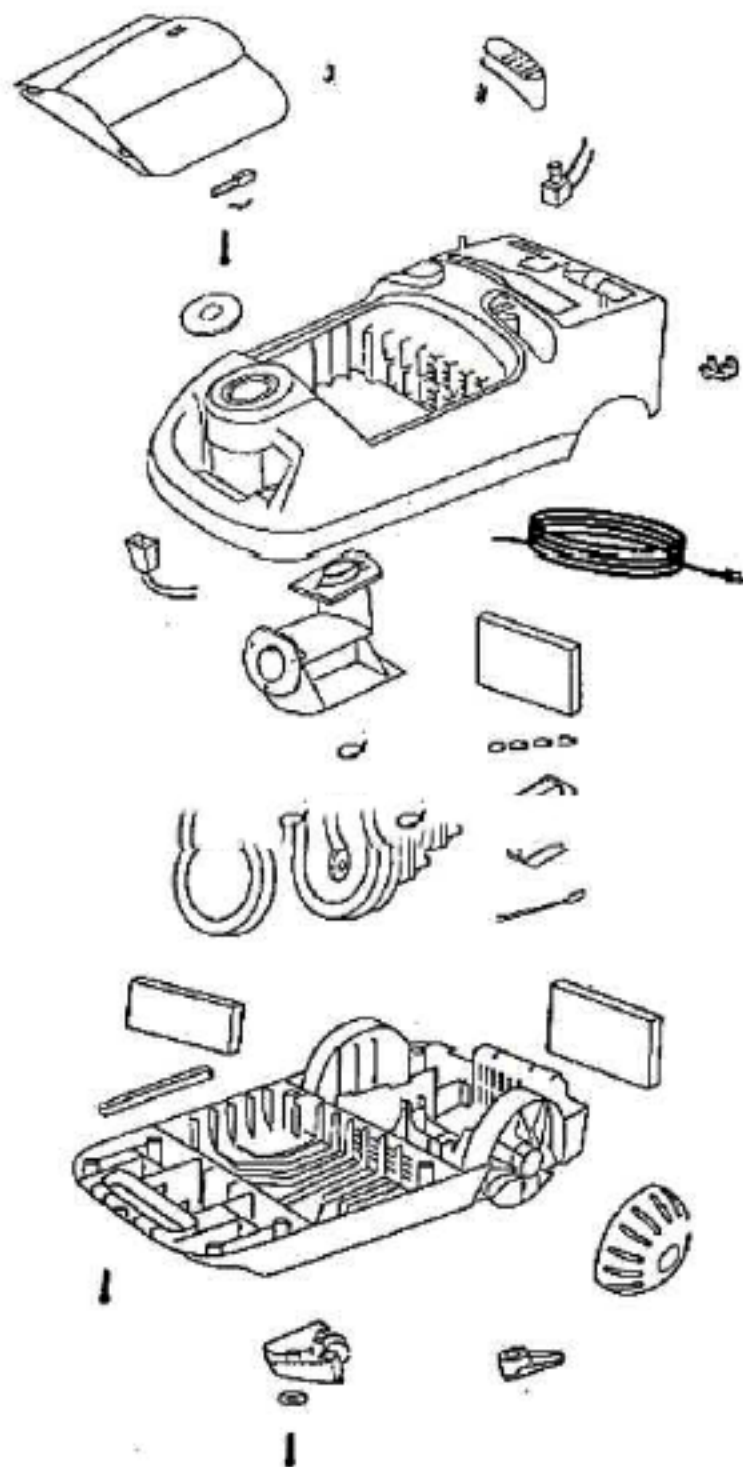

Ref #	Part	Description	Comments	Qty
1	14905-2	PLATE - HOSE		
2	26715A	GASKET - MOTOR MOUNTING		
3	26730-8	CONNECTOR & WIRE ASSEMBLY		
4	27329-1	CORD - LOW LEAD (17 GA)		
5	27380A-1	SEAL - SWIVEL HOSE		
6	36341-2	SWITCH - PUSH		
7	37403-1	CASTER		
8	37490-3	RELEASE - CORD		
9	37657	FILTER - MOTOR		
10	37710-1	FILTER - EXHAUST		
11	37761-1	BAG INDICATOR ASSEMBLY		
12	37966	SOUND FOAM		
13	38376-1	WHEEL - REAR		
14	38386-1	BUTTON		
15	46713-1	TIE - CABLE		
16	53197-1	SCREW PACKAGE		
17	53214-2	WIRE SPLICE 5		
18	53238-1	SCREW PACKAGE		
19	53238-8	SCREW PACKAGE		
20	54219-1	BUSHING - STRAIN RELIEF (		
21	54401	MOTOR ASSEMBLY - PACKAGED		
22	54635-6	BAG COVER & GRAPHICS - PK		
23	55463	GASKET - MOTOR STACK		
24	55794	SPRING		
25	56146	THERMOSTAT		
26	56326-1	TUBE - WIRE		
27	56376	WASHER		
28	56750	CLIP - BAG INDICATOR		

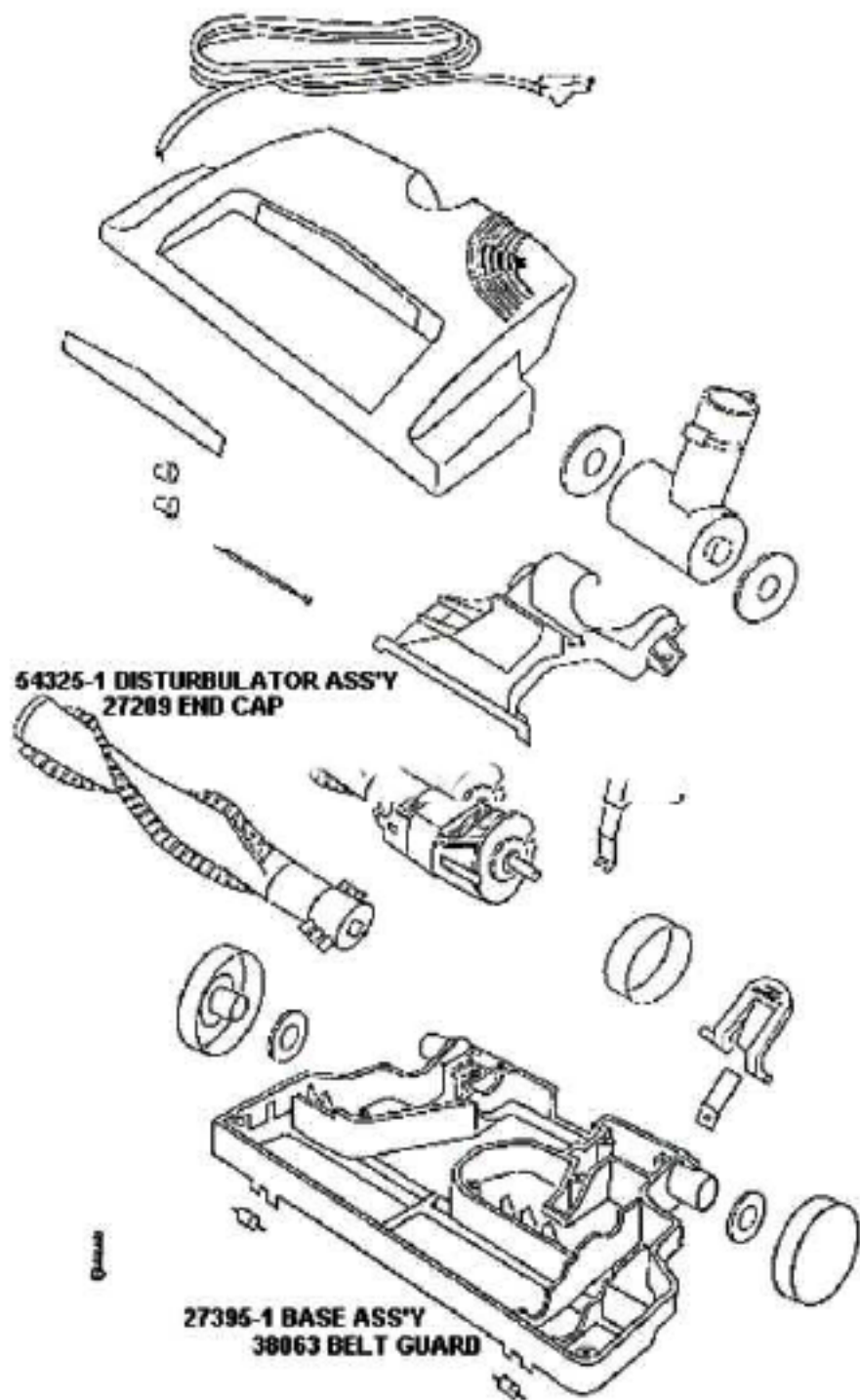

Ref #	Part	Description	Comments	Qty
1	14940-1	PEDAL - FOOT		
2	27395-1	POWERHEAD HOOD/BASE KIT		
3	27397-1	LENS - HOOD		
4	27398-1	AIR DUCT COVER ASSEMBLY		
5	35970-1B	POLARIZED CORD & PLUG ASS		
6	37434-2	WHEEL - REAR		
7	38063	GUARD - BELT		
8	38377	STRAP - MOTOR		
9	38379-1	HANDLE SOCKET ASSEMBLY		
10	53214-2	WIRE SPLICE 5		
11	53238-8	SCREW PACKAGE		
12	53984-1	WHEEL & AXLE PACKAGE - FR		
13	54325-1	DISTURBULATOR ASSY - CAR		
14	54343-1	MOTOR ASSEMBLY - PACKAGED		
15	54672-4	POWERHEAD HOOD/BASE KIT		
16	56180	FELT WASHER		
17	57421-2	WIRE & TERMINAL ASSEMBLY		
18	57992	GASKET - FELT		
19	58065	BELT - STYLE AR		
20	58169	SPRING		

54645-1 HOSE ASS'Y  
34272-5 BLEEDER  
38368-1 PLUG CLIP  
38358-2 CORD ASS'Y  
54655-2 HOSE  
CONNECTOR ASS'Y

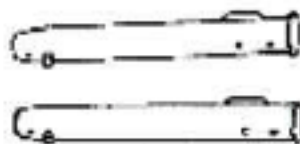
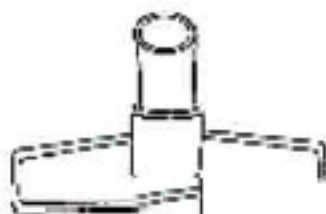
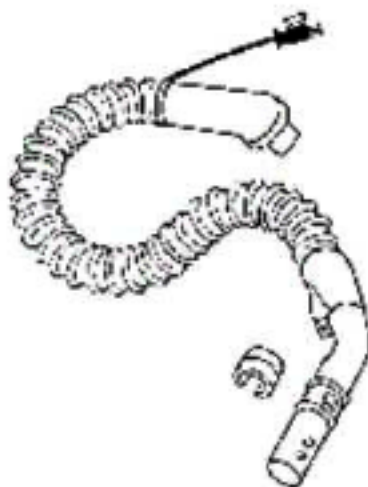

Ref #	Part	Description	Comments	Qty
1	34272-5	BLEEDER		
2	36879-5	STRAIGHT WAND ASSEMBLY		
3	38358-2	CORD & PLUG ASSY		
4	38368-1	CLIP - PLUG		
5	54355-3	TOOL - CREVICE		
6	54505-1	DUSTING BRUSH - PACKAGED		
7	54506-1	UPHOLSTERY NOZZLE ASSEMBL		
8	54533-5	FLOOR & WALL BRUSH - PACK		
9	54545-1	HOSE ASSEMBLY - CTND		
10	54655-2	CONNECTOR ASSY - HOSE (CR		
11	57698	PAPER BAG - STYLE V FA		

Ref #	Part	Description	Comments	Qty
1	14905-2	PLATE - HOSE		
2	26715A	GASKET - MOTOR MOUNTING		
3	26730-8	CONNECTOR & WIRE ASSEMBLY		
4	27329-1	CORD - LOW LEAD (17 GA)		
5	27380A-1	SEAL - SWIVEL HOSE		
6	36341-2	SWITCH - PUSH		
7	37403-1	CASTER		
8	37490-3	RELEASE - CORD		
9	37657	FILTER - MOTOR		
10	37710-1	FILTER - EXHAUST		
11	37761-1	BAG INDICATOR ASSEMBLY		
12	37966	SOUND FOAM		
13	38376-1	WHEEL - REAR		
14	38386-1	BUTTON		
15	46713-1	TIE - CABLE		
16	53197-1	SCREW PACKAGE		
17	53214-2	WIRE SPLICE 5		
18	53238-1	SCREW PACKAGE		
19	53238-8	SCREW PACKAGE		
20	54219-1	BUSHING - STRAIN RELIEF (		
21	54401	MOTOR ASSEMBLY - PACKAGED		
22	54635-6	BAG COVER & GRAPHICS - PK		
23	55463	GASKET - MOTOR STACK		
24	55794	SPRING		
25	56146	THERMOSTAT		
26	56326-1	TUBE - WIRE		
27	56376	WASHER		
28	56750	CLIP - BAG INDICATOR		

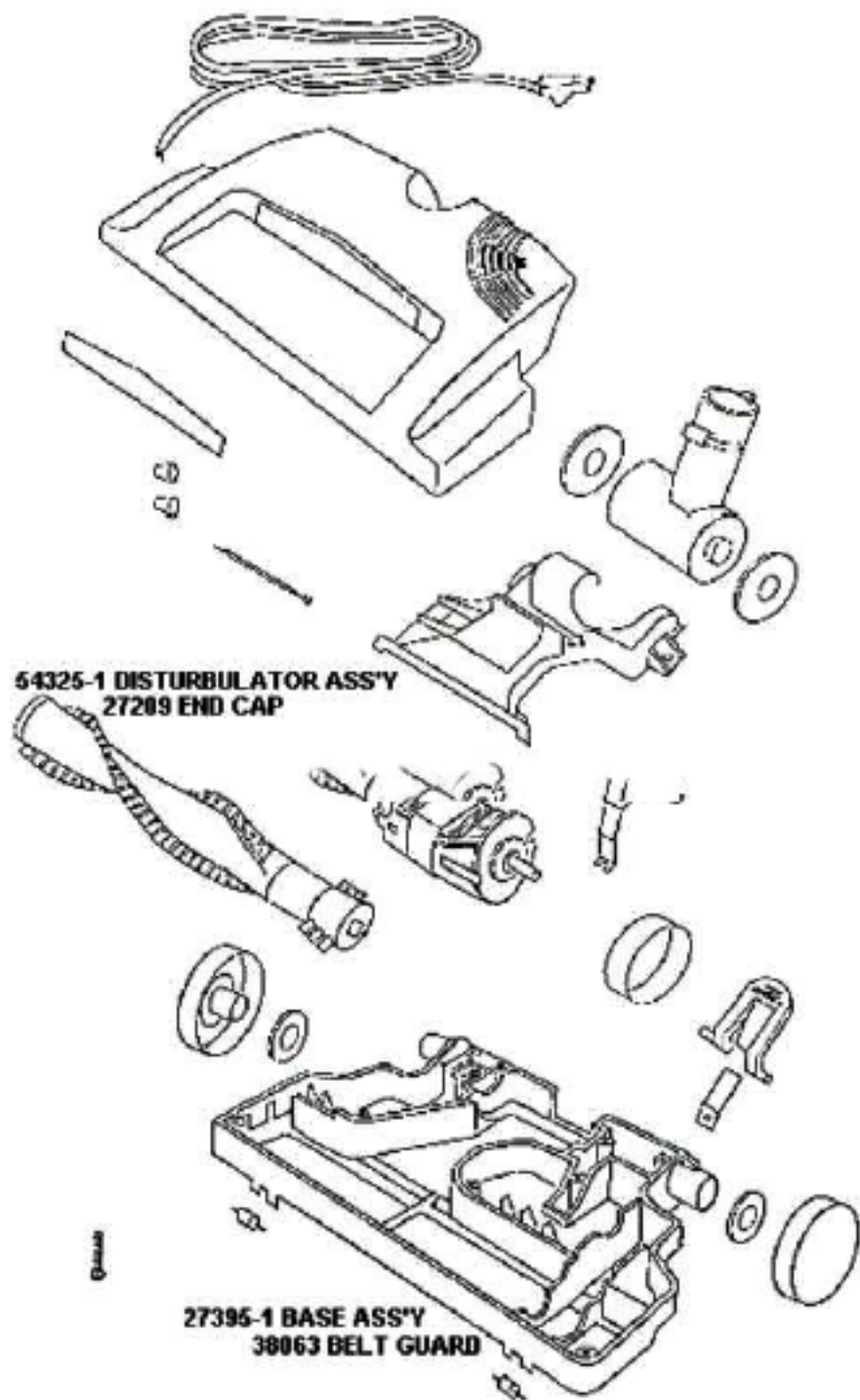

Ref #	Part	Description	Comments	Qty
1	14940-1	PEDAL - FOOT		
2	27395-1	POWERHEAD HOOD/BASE KIT		
3	27397-1	LENS - HOOD		
4	27398-1	AIR DUCT COVER ASSEMBLY		
5	35970-1B	POLARIZED CORD & PLUG ASS		
6	37434-2	WHEEL - REAR		
7	38063	GUARD - BELT		
8	38377	STRAP - MOTOR		
9	38379-1	HANDLE SOCKET ASSEMBLY		
10	53214-2	WIRE SPLICE 5		
11	53238-8	SCREW PACKAGE		
12	53984-1	WHEEL & AXLE PACKAGE - FR		
13	54325-1	DISTURBULATOR ASSY - CAR		
14	54343-1	MOTOR ASSEMBLY - PACKAGED		
15	54672-4	POWERHEAD HOOD/BASE KIT		
16	56180	FELT WASHER		
17	57421-2	WIRE & TERMINAL ASSEMBLY		
18	57992	GASKET - FELT		
19	58065	BELT - STYLE AR		
20	58169	SPRING		

54645-1 HOSE ASS'Y  
34272-5 BLEEDER  
38368-1 PLUG CLIP  
38358-2 CORD ASS'Y  
54655-2 HOSE  
CONNECTOR ASS'Y

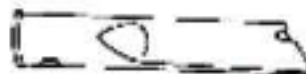
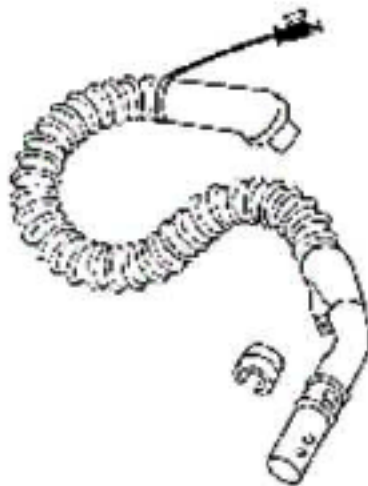

Ref #	Part	Description	Comments	Qty
1	34272-5	BLEEDER		
2	36879-5	STRAIGHT WAND ASSEMBLY		
3	38358-2	CORD & PLUG ASSY		
4	38368-1	CLIP - PLUG		
5	54355-3	TOOL - CREVICE		
6	54505-1	DUSTING BRUSH - PACKAGED		
7	54506-1	UPHOLSTERY NOZZLE ASSEMBL		
8	54533-5	FLOOR & WALL BRUSH - PACK		
9	54545-1	HOSE ASSEMBLY - CTND		
10	54655-2	CONNECTOR ASSY - HOSE (CR		
11	57698	PAPER BAG - STYLE V FA		