

**25329-35 UPPER HANDLE ASS'Y. (INCLUDES)  
35293-8 HANDLE GRIP**

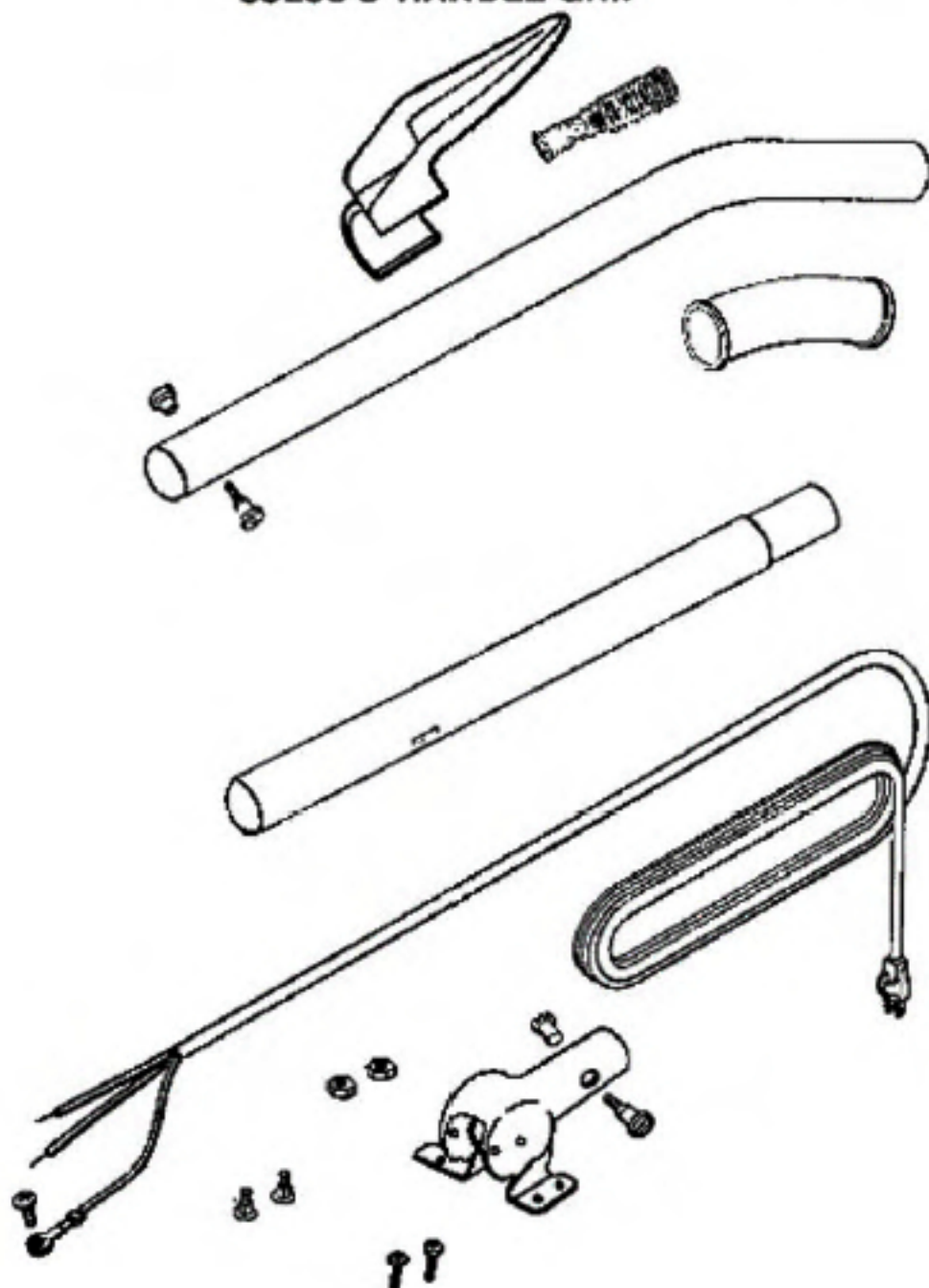

## PARTS4 - C2032A

Ref #	Part	Description	Comments	Qty
1	14766-2	RETAINER - CORD (UPPER)		
2	25329-35	HANDLE ASSY (UPPER)		
3	35293-8	GRIP - HANDLE		
4	38183-1	HANDLE SOCKET ASSY		
5	52370-14	CORD & TERMINAL ASSY 30 8		
6	53077	SPRING - STRAIN RELIEF PK		
7	53145	BOLT PACKAGE (10)		
8	53198-1	HANDLE SCREW ASSY PACKAGE		
9	53213-5	NUTS - PACKAGE 10		
10	53228-2	SCREWS - PACKAGE 10		
11	53238-13	SCREW PACKAGE		
12	57751-2	TUBE - HANDLE (LOWER)		

PARTS1 - C2032A

---



**NOT ILLUSTRATED**  
**24964A CAM (R.H.)**  
**24965A CAM (L.H.)**  
**53118 RIVET**  
**53133 WASHER**

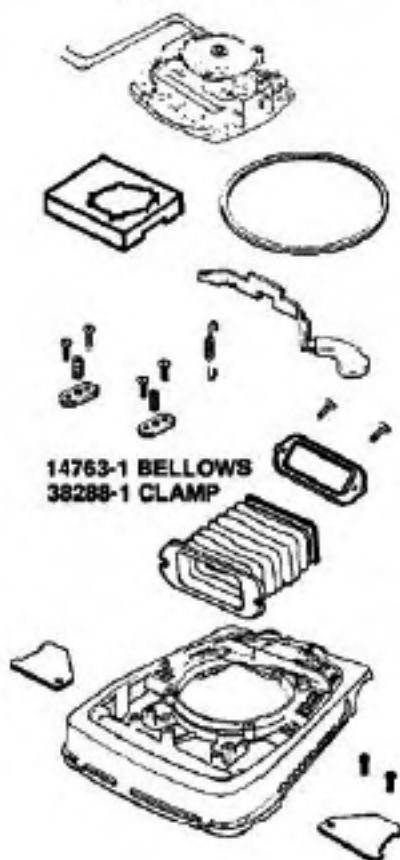

**14763-1 BELLOWS**  
**38288-1 CLAMP**

## PARTS1 - C2032A

Ref #	Part	Description	Comments	Qty
1	14783-1	BELLOWS		
2	24834A-1	Discontinued, use 24834A-3		
3	24964A	CAM (RIGHT)		
4	24965A	CAM (LEFT)		
5	26808-3	BUTTON - SWITCH		
6	30517	GASKET - MOTOR SEAL		
7	36263	COVER - WHEEL		
8	37989	CLIP - SWITCH		
9	38053-2	KNOB ASSEMBLY		
10	38067	SEPARATOR ASSEMBLY		
11	38218-1	BRACKET - BUSHING		
12	38288-1	CLAMP - BELLOWS		
13	53097	SPRING - FOOT PEDAL PKG (		
14	53118	RIVET - SHOULDER PACKAGE		
15	53122	STRAIN RELIEF BUSHING - P		
16	53133	STL WASHERS- PKG (48495 (NLA)		
17	53140	CLAMP & SCREW ASSY PKG		
18	53143	SCREW PACKAGE (10)		
19	53214-1	WIRE SPLICE 5		
20	53228-7	SCREWS - PACKAGE 10		
21	53238-13	SCREW PACKAGE		
22	53238-14	SCREW PACKAGE		
23	54005-5	HOOD ASSEMBLY - PACKAGED		
24	54151-2	Discontinued, use 13738-5		
25	54177	WIRE & TERMINAL ASSY		
26	54352-3	MOTOR ASSEMBLY - PACKAGED		
27	57902-1	BASE ASSEMBLY - 12" - CAR		
28	EW29-8-12ZP	SCREW PACKAGE		

PARTS5 - C2032A

---

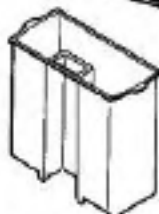

54422-2 BAG ASS'Y.  
57684 BAG GASKET



14844-1 DIRT CUP ASS'Y. (INCLUDES)  
54492-1 DIRT CUP SUPPORT  
& LATCH ASS'Y.  
14785-1 BAG FLANGE  
55399-1 COVER PIN  
01958-1 DIRT CUP  
38289 GASKET  
26265-2 CLAMP

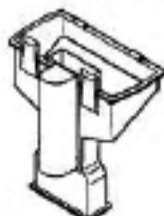

57838 HARDWARE PKG.  
1-CORD RETAINER  
2-HANDLE SCREW ASS'Y.  
2-BAG SCREW  
1 CABLE CLAMP  
1-SCREW



## PARTS5 - C2032A

Ref #	Part	Description	Comments	Qty
1	01959-1	Discontinued, use 01959-313N		
2	14765-1	FLANGE - BAG (OUTER)		
3	14844-1	DIRT CUP ASSY		
4	26266-2	CLAMP		
5	38289	GASKET		
6	54422-2	BAG ASSEMBLY - PACKAGED		
7	54492-1	SUPPORT & LATCH ASSY - PK		
8	55399-1	PIN COVER		
9	57684	GASKET - DIRTCUP		
10	57686-1	HOOK - SNAP		
11	57711	RING STEEL		
12	57838	HARDWARE PKG		



**37234-1 WHEEL & AXLE ASS'Y. (INCLUDES)**  
**53110 WHEEL WASHER**  
**37183 REAR AXLE**  
**53121 PUSHNUT**



**NOTE**  
**PT. NO. 53270**  
**DISTURBULATOR ASS'Y.**  
**INCLUDES**

**13236-1 DISTURBULATOR TUBE**  
**52282-4 BRISTLE STRIP ASS'Y.**  
**53084 DISTURBULATOR CAP**  
**53079 BEARING RETAINER**  
**49899 FELT WASHER**  
**53158 LOCK NUT**  
**53184 KLIPRING**  
**25937 SHAFT**



**25922-1 BOTTOM PLATE ASS'Y. (INCLUDES)**  
**46538 FOAM TAPE**



## PARTS3 - C2032A

Ref #	Part	Description	Comments	Qty
1	13236-1	TUBE - DISTURBULATOR		
2	25922-1	BOTTOM PLATE ASSEMBLY		
3	25937	SHAFT - DISTURBULATOR		
4	26242-1	REAR WHEEL use 26242-119N		
5	26296-9	Discontinued, use 27564-1		
6	35859A-1	WHEEL - FRONT		
7	35947A	AXLE - FRONT		
8	37183	AXLE - REAR		
9	37234-1	WHEEL & AXLE ASSY		
10	46538	TAPE-FOAM (use 46538-4)		
11	49899	WASHER - FELT		
12	52282-4	BRISTLE STRIP PACKAGE		
13	53064	CAP - DISTURBULATOR		
14	53066	CAP - COVER		
15	53076-2	SPRING & AXLE PACKAGE (8)		
16	53079	BEARING & RETAINER ASSEMB		
17	53110	WASHER - WHEEL PACKAGE (1)		
18	53121	PUSH NUT PACKAGE (10)		
19	53158	LOCK NUT PACKAGE		
20	53184	KLIPRING PACKAGE		
21	53201	AXLE CLAMP - PACKAGED		
22	53238-11	SCREW PACKAGE		
23	53270	DISTURBULATOR ASSEMBLY		



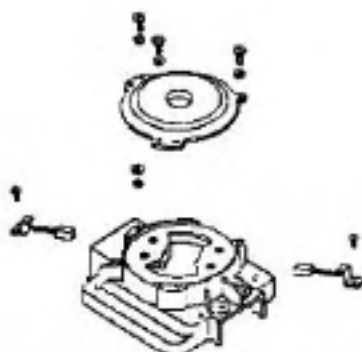

**54395-4 ARMATURE & FAN ASS'Y.**  
**30474A FAN**



**54169-1 MOTOR BASE ASS'Y.**  
**42875 BEARING & RETAINER**  
**53088-1 BEARING (PKG. OF 5)**  
**53187-1 RIVET (PKG. OF 10)**

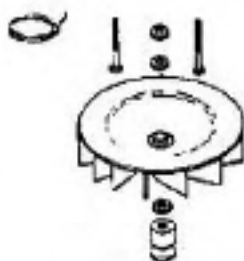

## PARTS2 - C2032A

Ref #	Part	Description	Comments	Qty
1	12988	FAN BLOWER - MOTOR		
2	20217E	RETAINER - UPPER BEARING		
3	30474A	FAN - MOTOR COOLING		
4	30478	MOTOR BRUSH ASSEMBLY		
5	37012-2	PULLEY - MOTOR DRIVE		
6	42875	BEARING RETAINER ASSY-W/L		
7	53088-1	BALL BEARING - PACKAGE		
8	53138	SCREWS - PACKAGE 10		
9	53142	SCREW PACKAGE (10)		
10	53148	WASHER - FAN PACKAGE (10)		
11	53187-1	RIVET PACKAGE		
12	53188-1	WASHER PACKAGE		
13	53213-4	NUTS - PACKAGE 10		
14	53219-2	SCREWS - PACKAGE 10		
15	53222-3	LOCKWASHERS - PACKAGE 10		
16	53441-2	FIELD ASSEMBLY - PACKAGED		
17	54189-1	MOTOR BASE ASSEMBLY		
18	54352-3	MOTOR ASSEMBLY - PACKAGED		
19	54395-4	ARMATURE, FAN & BRG ASSY-		
20	54396	MOTOR COVER ASSEMBLY - LA		
21	56802-2	TIE - CABLE (PURCHASED)		

## PARTS4 - C2032A

Ref #	Part	Description	Comments	Qty
1	14766-2	RETAINER - CORD (UPPER)		
2	25329-35	HANDLE ASSY (UPPER)		
3	35293-8	GRIP - HANDLE		
4	38183-1	HANDLE SOCKET ASSY		
5	52370-14	CORD & TERMINAL ASSY 30 8		
6	53077	SPRING - STRAIN RELIEF PK		
7	53145	BOLT PACKAGE (10)		
8	53198-1	HANDLE SCREW ASSY PACKAGE		
9	53213-5	NUTS - PACKAGE 10		
10	53228-2	SCREWS - PACKAGE 10		
11	53238-13	SCREW PACKAGE		
12	57751-2	TUBE - HANDLE (LOWER)		

PARTS1 - C2032A

---



**NOT ILLUSTRATED**  
**24964A CAM (R.H.)**  
**24965A CAM (L.H.)**  
**53118 RIVET**  
**53133 WASHER**



**14763-1 BELLOWS**  
**38288-1 CLAMP**

## PARTS1 - C2032A

Ref #	Part	Description	Comments	Qty
1	14783-1	BELLOWS		
2	24834A-1	Discontinued, use 24834A-3		
3	24964A	CAM (RIGHT)		
4	24965A	CAM (LEFT)		
5	26808-3	BUTTON - SWITCH		
6	30517	GASKET - MOTOR SEAL		
7	36263	COVER - WHEEL		
8	37989	CLIP - SWITCH		
9	38053-2	KNOB ASSEMBLY		
10	38067	SEPARATOR ASSEMBLY		
11	38218-1	BRACKET - BUSHING		
12	38288-1	CLAMP - BELLOWS		
13	53097	SPRING - FOOT PEDAL PKG (		
14	53118	RIVET - SHOULDER PACKAGE		
15	53122	STRAIN RELIEF BUSHING - P		
16	53133	STL WASHERS- PKG (48495 (NLA)		
17	53140	CLAMP & SCREW ASSY PKG		
18	53143	SCREW PACKAGE (10)		
19	53214-1	WIRE SPLICE 5		
20	53228-7	SCREWS - PACKAGE 10		
21	53238-13	SCREW PACKAGE		
22	53238-14	SCREW PACKAGE		
23	54005-5	HOOD ASSEMBLY - PACKAGED		
24	54151-2	Discontinued, use 13738-5		
25	54177	WIRE & TERMINAL ASSY		
26	54352-3	MOTOR ASSEMBLY - PACKAGED		
27	57902-1	BASE ASSEMBLY - 12" - CAR		
28	EW29-8-12ZP	SCREW PACKAGE		

PARTS5 - C2032A

---

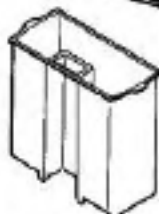

54422-2 BAG ASS'Y.  
57684 BAG GASKET



14844-1 DIRT CUP ASS'Y. (INCLUDES)  
54492-1 DIRT CUP SUPPORT  
& LATCH ASS'Y.  
14785-1 BAG FLANGE  
55399-1 COVER PIN  
01959-1 DIRT CUP  
38289 GASKET  
26265-2 CLAMP

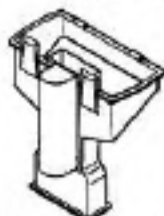

57838 HARDWARE PKG.  
1-CORD RETAINER  
2-HANDLE SCREW ASS'Y.  
2-BAG SCREW  
1 CABLE CLAMP  
1-SCREW



## PARTS5 - C2032A

Ref #	Part	Description	Comments	Qty
1	01959-1	Discontinued, use 01959-313N		
2	14765-1	FLANGE - BAG (OUTER)		
3	14844-1	DIRT CUP ASSY		
4	26266-2	CLAMP		
5	38289	GASKET		
6	54422-2	BAG ASSEMBLY - PACKAGED		
7	54492-1	SUPPORT & LATCH ASSY - PK		
8	55399-1	PIN COVER		
9	57684	GASKET - DIRTCUP		
10	57686-1	HOOK - SNAP		
11	57711	RING STEEL		
12	57838	HARDWARE PKG		



**37234-1 WHEEL & AXLE ASS'Y. (INCLUDES)**  
**53110 WHEEL WASHER**  
**37183 REAR AXLE**  
**53121 PUSHNUT**

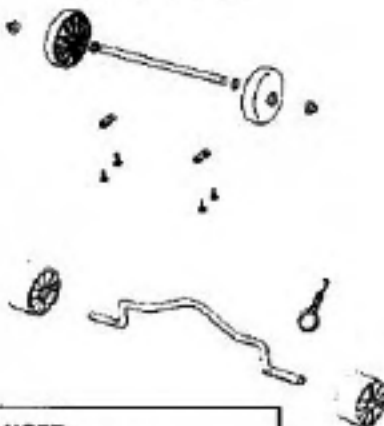

**NOTE**  
**PT. NO. 53270**  
**DISTURBULATOR ASS'Y.**  
**INCLUDES**

**13236-1 DISTURBULATOR TUBE**  
**52282-4 BRISTLE STRIP ASS'Y.**  
**53084 DISTURBULATOR CAP**  
**53079 BEARING RETAINER**  
**49899 FELT WASHER**  
**53158 LOCK NUT**  
**53184 KLIPRING**  
**25937 SHAFT**



**25922-1 BOTTOM PLATE ASS'Y. (INCLUDES)**  
**46538 FOAM TAPE**





## PARTS3 - C2032A

Ref #	Part	Description	Comments	Qty
1	13236-1	TUBE - DISTURBULATOR		
2	25922-1	BOTTOM PLATE ASSEMBLY		
3	25937	SHAFT - DISTURBULATOR		
4	26242-1	REAR WHEEL use 26242-119N		
5	26296-9	Discontinued, use 27564-1		
6	35859A-1	WHEEL - FRONT		
7	35947A	AXLE - FRONT		
8	37183	AXLE - REAR		
9	37234-1	WHEEL & AXLE ASSY		
10	46538	TAPE-FOAM (use 46538-4)		
11	49899	WASHER - FELT		
12	52282-4	BRISTLE STRIP PACKAGE		
13	53064	CAP - DISTURBULATOR		
14	53066	CAP - COVER		
15	53076-2	SPRING & AXLE PACKAGE (8)		
16	53079	BEARING & RETAINER ASSEMB		
17	53110	WASHER - WHEEL PACKAGE (1)		
18	53121	PUSH NUT PACKAGE (10)		
19	53158	LOCK NUT PACKAGE		
20	53184	KLIPRING PACKAGE		
21	53201	AXLE CLAMP - PACKAGED		
22	53238-11	SCREW PACKAGE		
23	53270	DISTURBULATOR ASSEMBLY		

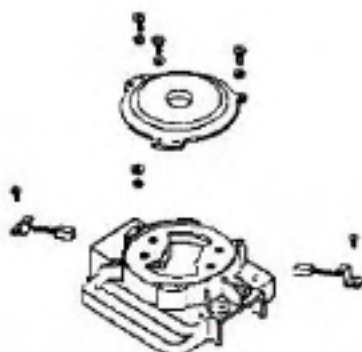

**54395-4 ARMATURE & FAN ASS'Y.**  
**30474A FAN**



**54169-1 MOTOR BASE ASS'Y.**  
**42875 BEARING & RETAINER**  
**53088-1 BEARING (PKG. OF 5)**  
**53187-1 RIVET (PKG. OF 10)**

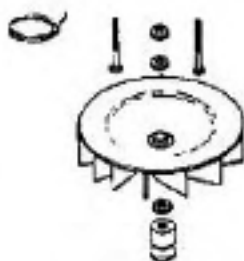

## PARTS2 - C2032A

Ref #	Part	Description	Comments	Qty
1	12988	FAN BLOWER - MOTOR		
2	20217E	RETAINER - UPPER BEARING		
3	30474A	FAN - MOTOR COOLING		
4	30478	MOTOR BRUSH ASSEMBLY		
5	37012-2	PULLEY - MOTOR DRIVE		
6	42875	BEARING RETAINER ASSY-W/L		
7	53088-1	BALL BEARING - PACKAGE		
8	53138	SCREWS - PACKAGE 10		
9	53142	SCREW PACKAGE (10)		
10	53148	WASHER - FAN PACKAGE (10)		
11	53187-1	RIVET PACKAGE		
12	53188-1	WASHER PACKAGE		
13	53213-4	NUTS - PACKAGE 10		
14	53219-2	SCREWS - PACKAGE 10		
15	53222-3	LOCKWASHERS - PACKAGE 10		
16	53441-2	FIELD ASSEMBLY - PACKAGED		
17	54189-1	MOTOR BASE ASSEMBLY		
18	54352-3	MOTOR ASSEMBLY - PACKAGED		
19	54395-4	ARMATURE, FAN & BRG ASSY-		
20	54396	MOTOR COVER ASSEMBLY - LA		
21	56802-2	TIE - CABLE (PURCHASED)		