

**25329-20 UPPER HANDLE ASS'Y. (INCLUDES)
35293-8 HANDLE GRIP**

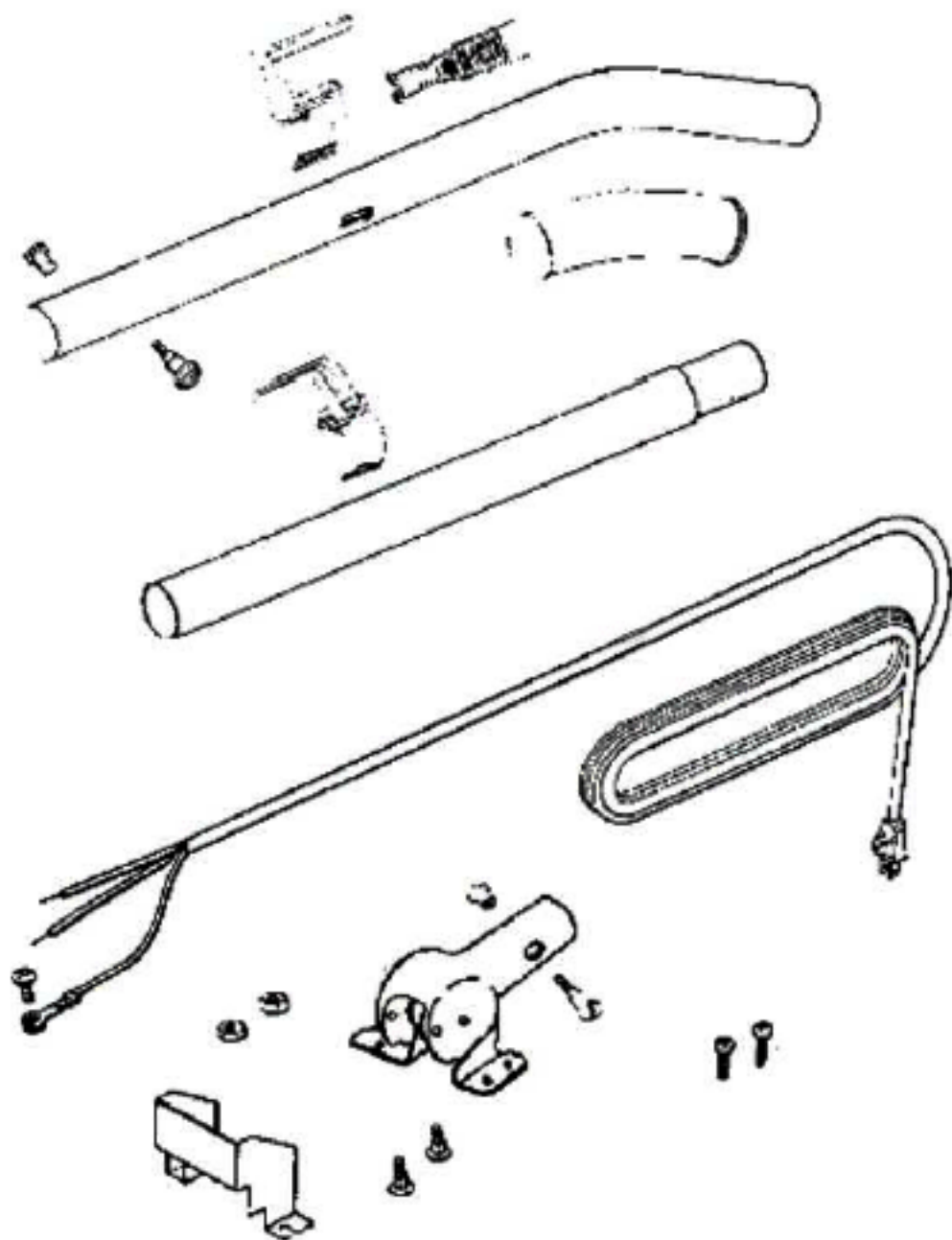

Ref #	Part	Description	Comments	Qty
1	25329-20	HANDLE ASSEMBLY (UPPER)		
2	35293-8	GRIP - HANDLE		
3	36439	SHIELD - HANDLE SOCKET		
4	38183-1	HANDLE SOCKET ASSEMBLY		
5	52370-12	CORD & TERMINAL ASSY-FB-5		
6	53077	SPRING - STRAIN RELIEF PK		
7	53145	BOLT PACKAGE (10)		
8	53198-1	HANDLE SCREW ASSY PACKAGE		
9	53213-5	NUTS - PACKAGE 10		
10	53238-11	SCREW PACKAGE		
11	53238-13	SCREW PACKAGE		
12	53574-1	CORD RETAINER SET		
13	57751-1	TUBE - HANDLE (LOWER)		

54097-2 HOOD & NAMEPLATE ASS'Y.
37654 NAMEPLATE
55754 DECAL



50379 AIR INLET DUCT ASS'Y. (R.H.)
49052-3 FOAM TAPE



56380 AIR INLET DUCT ASS'Y.
49052-3 FOAM TAPE



214A C₃ (R.H.)
RO1 (ILLUSTRATED)
24964A CAM (R.H.)
24965A CAM (L.H.)
53118 RIVET-CAM PKG. 10 2 USED
53133 WASHER PKG. 10 2 USED



52334 FAN CHAMBER REPLACEMENT KIT (INCLUDES)
30517 MOTOR SEAL GASKET
13770-1 FAN CHAMBER COVER
53238-14 SCREW
PKG. 10 2 USED

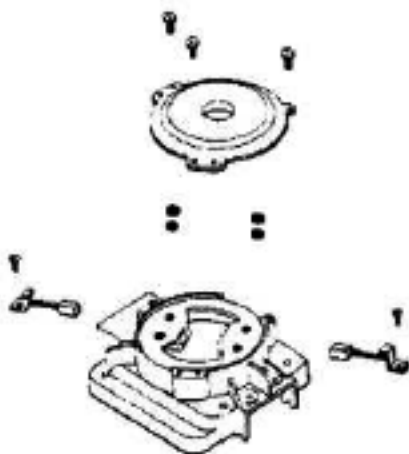

Ref #	Part	Description	Comments	Qty
1	13770-1	COVER - FAN SCROLL		
2	24834A-1	PEDAL - FOOT		
3	24964A	CAM (RIGHT)		
4	24965A	CAM (LEFT)		
5	26833-1	KNOB ASSEMBLY		
6	30517	GASKET - MOTOR SEAL		
7	36283	COVER - WHEEL		
8	36409-13	SWITCH - PUSH		
9	37034	SPRING - ADAPT RETAINER		
10	37654	NAMEPLATE		
11	49052-3	TAPE - FOAM		
12	52334	FAN CHAMBER REPLACEMENT K		
13	53097	SPRING - FOOT PEDAL PKG (
14	53102	LOCKWASHER PACKAGE (10)		
15	53117	SPRING - HOOD PACKAGE (10)		
16	53118	RIVET - SHOULDER PACKAGE		
17	53122	STRAIN RELIEF BUSHING - P		
18	53133	STEEL WASHERS - PACKAGE 1		
19	53140	CLAMP & SCREW ASSY PKG		
20	53143	SCREW PACKAGE (10)		
21	53160	CABLE CLAMP PACKAGE		
22	53213-4	NUTS - PACKAGE 10		
23	53214-1	WIRE SPLICE 5		
24	53228-2	SCREWS - PACKAGE 10		
25	53238-11	SCREW PACKAGE		
26	53238-13	SCREW PACKAGE		
27	53238-14	SCREW PACKAGE		
28	53474-3	BASE ASSEMBLY - CARTONED		
29	54097-2	HOOD & NAMEPLATE ASSY - P		
30	54173-1	WIRE ASSY (GROUNDING)		
31	54177	WIRE & TERMINAL ASSY		
32	54352-11	MOTOR ASSEMBLY - PACKAGED		
33	55446	NUT - SWITCH		
34	55754	DECAL		
35	56379	AIR INLET DUCT (R.H.)		
36	56380	AIR INLET DUCT (L.H.)		

**54395-4 ARM, FAN & BEARING ASSEMBLY**

53088-1 BEARING PKG. 5 1 USED
30474A FAN

**54169 MOTOR BASE ASSEMBLY**

42875 BEARING & RETAINER ASS'Y.
53088-1 BEARING PKG. 5 1 USED
53187-1 RIVET PKG. 10 3 USED

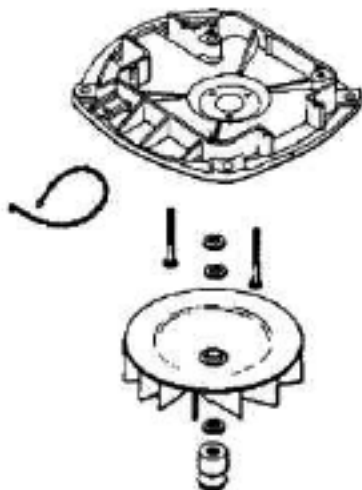

Ref #	Part	Description	Comments	Qty
1	12988	FAN BLOWER - MOTOR		
2	20217E	RETAINER - UPPER BEARING		
3	30474A	FAN - MOTOR COOLING		
4	30478	MOTOR BRUSH ASSEMBLY		
5	37012-2	PULLEY - MOTOR DRIVE		
6	42875	BEARING RETAINER ASSY-W/L		
7	53088-1	BALL BEARING - PACKAGE		
8	53142	SCREW PACKAGE (10)		
9	53148	WASHER - FAN PACKAGE (10)		
10	53158	LOCK NUT PACKAGE		
11	53187-1	RIVET PACKAGE		
12	53188-1	WASHER PACKAGE		
13	53213-4	NUTS - PACKAGE 10		
14	53219-2	SCREWS - PACKAGE 10		
15	53222-3	LOCKWASHERS - PACKAGE 10		
16	53441-10	FIELD ASSEMBLY - PACKAGED		
17	54169	MOTOR BASE ASSEMBLY		
18	54395-4	ARMATURE, FAN & BRG ASSY-		
19	54396	MOTOR COVER ASSEMBLY - LA		
20	56802-2	TIE - CABLE		

54174-1 BAG ADAPTER
48282 GASKET
48748 WASHER
48749 RIVET



49461-A HARDWARE PKG. (INCLUDES)
1-CORD RETAINER SET
2-HDLE. SCREW ASS'Y.

Ref #	Part	Description	Comments	Qty
1	30599D-10	CLIP - BAG		
2	47722	SPRING - BAG		
3	48292	GASKET - BAG ADAPTER		
4	48748	WASHER		
5	48749	PACKAGE - RIVET		
6	53354-3	BAG ASSEMBLY - PACKAGED		
7	54174-1	ADAPTER - BAG		



37234-1 WHEEL & AXLE ASS'Y.(INCLUDES)
53110 WHEEL WASHER
PKG. 10 2 USED
37183 REAR AXLE
53121 PUSHNUT
PKG. 10 2 USED



NOTE
PT. NO. 53270
DISTURBULATOR ASS'Y.
INCLUDES

52282-4 BRISTLE STRIP ASS'Y.
49899 FELT WASHER
53079 BEARING RETAINER
495899899 W.AER
53158 LOCK W. NUBBULA
PKG. 2 2 USED
13238-1 DISTURBULATOR TUBE
53158 LOCK NUT
PKG. 10 2 USED
53184 KLIPRING
PKG. 10 2 USED
25937 SHAFT



25922-1 BOTTOM PLATE ASS'Y. (INCLUDES)
46538 FOAM TAPE



Ref #	Part	Description	Comments	Qty
1	13236-1	TUBE - DISTURBULATOR		
2	25922-1	BOTTOM PLATE ASSEMBLY		
3	25937	SHAFT - DISTURBULATOR		
4	26242-1	WHEEL - REAR		
5	26296-9	GUARD - FURNITURE		
6	35859A-1	WHEEL - FRONT		
7	35947A	AXLE - FRONT		
8	37183	AXLE - REAR		
9	37234-1	WHEEL & AXLE ASSY		
10	46538	TAPE - FOAM		
11	49899	WASHER - FELT		
12	52282-4	BRISTLE STRIP PACKAGE		
13	53064	CAP - DISTURBULATOR		
14	53066	CAP - COVER		
15	53076-2	SPRING & AXLE PACKAGE (6)		
16	53079	BEARING & RETAINER ASSEMB		
17	53110	WASHER - WHEEL PACKAGE (1		
18	53121	PUSH NUT PACKAGE (10)		
19	53158	LOCK NUT PACKAGE		
20	53184	KLI PRING PACKAGE		
21	53238-11	SCREW PACKAGE		
22	53270	DISTURBULATOR ASSEMBLY		
23	55535-2	CLAMPS - PACKAGE 10		