

Ref. No.	Part No.	Description
1	38335009	Support Spring
2	43667040	Cloth Bag - AAW/AG
3	35173001	Bag Expander - AG
4	34112015	Seal
5	41427013	Dust Cup Support & Bellows
6	36155011	Latch - AG (2)
7	34123020	Gasket
8	38775001	Dust Cup
9	43675143	+ Dust Cup Assm.
10	51151034	Indicator - AG
11	38456044	Nozzle Adjustment Lever - AG
12	27479307	* Cable Tie
13	21481273	* Screw - Self Tapping (2)
14	37954001	Bail Cover Plate - AG
15	48969	* Wire Nut (4)
16	21354155	* Lock Washer - Special
17	34223004	Strain Relief Mounting Plate
18	23187363	Screw - Self Tapping
19	21631302	Handle Bolt (2)
20	35463011	Handle Retainer Plate
21	39049	Strain Relief Bushing
22	41416064	Bail Assem. (Inc. it 13,14,17,19,20,25)
23	12560	* Switch Nut
24	48631134	Lower Handle - AX
25	32277008	Handle Nut (2)
26	13704	* Lock Washer (2)
27	48646093	Handle Comp. - AX
28	48643091	Handle Upper Half - AX
29	39454070	Handle Grip - BU
30	46583149	Attach. Cord - 35' - AAW
31	34785017	Cord Retaining Clamp - AX
32	36215025	Cord Protector
33	38424003	Switch Pedal - PH
34	24735022	* Circlip
35	41424011	Bag Flange Assm.
36	36425023	Clamp
37	38673001	Bellows - AG
38	35217006	Mounting Bracket - AW
39	613802AY	* Shaft
40	28212017	Switch
41	38426080	Foot Pad - AG
42	11735	Roller Detent Assm.
43	48409FW	Spring
44	19907	Bag Flange Clamp Lever
45	13730	* Lock Ring (4)
46	46515007	Bail Cord/Tubing Assm.
47	38456050	Handle Control Lever
48	47450AY	Pivot Pin
49	43263005	Cam Follower
50	41431013	Wheel Shaft & Support Assm.
51	34252005	* Yoke
52	161513	Spring
53	21312806	* Washer
54	27479307	* Lead Wire Tie
55	41961009	Indicator Guide
56	35276006	Indicator Guide Spring
57	41119009	Retainer & Sleeving Assm.
58	21447211	+* Screw - Self Tapping (4)
59	168278AY	+* Washer (4)
60	12997AW	* Rivet (2)
61	36951004	Retainer (2)
62	21256134	* Rivet (2)
63	48111008	Indicator Lens
64	42251168	Hood Assm. - AAW
65	37246040	Panel - AAW
66	52115199	+ Hood Nameplate
67	36231151	Furniture Guard - BU
68	45533AY	+* Screw

Ref. No.	Part No.	Description
69	14062	* Lock Washer
70	40309020	Motor Assm. Comp. - (P - 195)
71	12559FW	Spring
72	21447229	* Screw - Self Tapping
73	34665007	Pivot Pin Retainer
74	34791AG	Carrier Wheel (2)
75	21312724	* Washer (2)
76	47457AY	Wheel Shaft (2)
77	48422	* Rivet - Tubular (2)
78	42242277	Main Body - AG
79	21312781	Washer (2)
80	34784021	Agitator Retaining Spring - AY (2)
81	N/A	
82	N/A	
83	48414021	Agitator Assm. Comp. - HE
84	44783AG	Belt
85	34111001	* Support Pad (2)
86	37245081	Bottom Plate - AG
87	36153006	Bottom Plate Latch (2)
88	21447229	Screw - Self Tapping (2)
89	21447020	* Screw - Self Tapping (2)
90	21447229	Screw - Self Tapping (2)
91	35434040	Axle/Bag Flange Retainer
92	38521019	Rear Wheel - AG (2)
93	32182001	* Wheel Retainer (2)
94	161509AY	Bail Shaft
95	21256094	* Rivet
96	39441016	Cord Clip - AG
97	41128021	Bag Clip & Spring

PACKAGING MATERIAL

58174078	+ Cleaner Carton
56711081	+ Assm. Instruction Sheet
56711082	+ Operation Instruction Folder
58216006	Dirt Cup Middle Pad
58343025	Front Support
58366012	Rear Support

Agitator 48414021

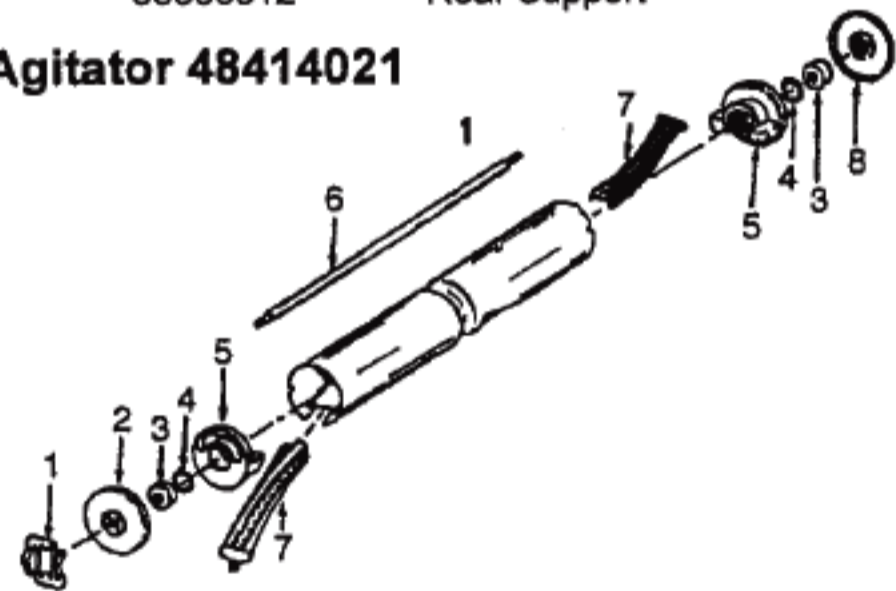

Ref. No.	Part No.	Description
1	35366	Thrust Spring
2	48495AY	Thread Guard - LH
3	43267002	Bearing
4	21347003	* Washer
5	41435070	End
6	32724008	Shaft
7	48445001	Agitator Brush
8	12985AY	Thread Guard - RH

Motor 40309020
I-Speed w/o Guide

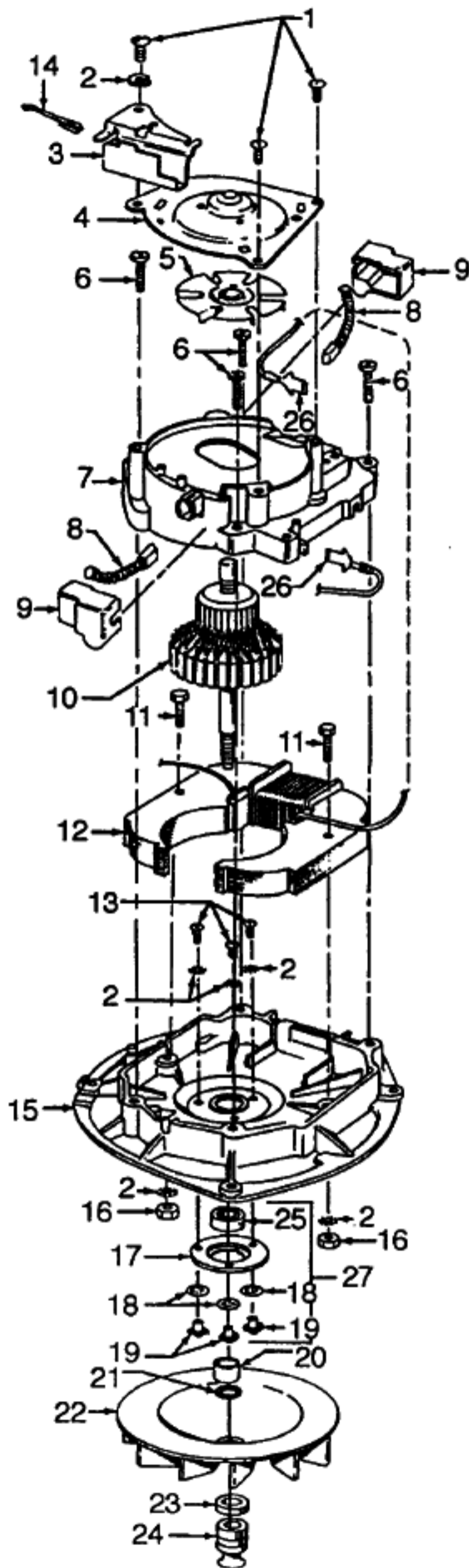

Ref. No.	Part No.	Description
1	45533AY	+* Screw
2	14062	* Washer
3	41961009	Indicator Guide
4	42934002	Motor Casing Cap Assm.
5	38755005	Vent Fan
6	161535	* Screw
7	42195003	Upper Motor Casing
8	47318012	Carbon Brush
9	36315003	Brush Insulator
10	44768043	Armature
11	45118	* Bolt
12	45412015	Field Coil
13	21772501	* Screw
14	35276006	Indicator Guide Spring
15	42193006	Lower Motor Case
16	15673	* Nut
17	32184003	Retainer
18	19772	* Washer
19	45251	Nut
20	31731002	Spacer
21	166563	* Washer
22	38755011	Fan - Poly
23	31162004	* Washer - Heat Insulating
24	38532009	Motor Pulley
25	24152807	Bearing
26	14320	* Terminal
27	43267006	Bearing Kit