

Handle & Tank

Models F5019, F5047, F5300, F5300-060

Ref.	Part Description	No.	No.
1	16486		Push Rod
	15535FW	+*	Spring
3	21312722	*	Washer
4	42272074		Tank Housing Comp.
5	16217	+	Defoamer Cake
6	16126	+	Gasket
7	42272101		Separator Cover
	42272102		Separator Cover - AAP - F5047
	42272103		Separator Cover - AG - F5300, F5300-060
8	16125AY	+	Capsert
9	40404011	+	Tank Gasket
10	51661004		Medallion
	51661016		Medallion - F5047
11	13759	*	Lock Ring
12	18526	+	Bail Pivot Stud
13	18525	*	Washer
14	43646009		Tank Assem. Comp. - AAM (incl. Item 23 thru 32)
	43646010		Tank Assem. Comp. - AG - F5300, F5300-060 (Incl. Items 23 thru 32)
15	21347003	*	Washer
16	15869	*	Washer
17	21652005	*	Nut - Hex
18	13306	*	Retaining Ring
19	21312713	+*	Washer
20	15566	+*	Cord Retainer
21	16297	+*	Screw
22	16379JM		Cord Cover Tubing
23	15409		Tank Valve Nut (2)
24	15611		Spring
25	21294056	+*	Eyelet
26	15590	+*	Washer
27	21312712		Washer
28	15407		Tank Valve Gasket
29	15408		Tank Valve Stem
30	18805	*	Screw (4)
31	15380JM		Tank Cap
32	18609JM	+	Tank Handle & Bag
	43631006		Tank Handle & Bag - AAM - F5047
	N/A		Tank Handle & Bag - AG - F5300, F5300-060 (Use Tank Assembly Complete - Item 14)
33	161432	+	Nut Insulator
	31562004		Nut Insulator - AG - F5300, F5300-060

Ref.	Part Description	No.	No.
34	164689		Tank Valve Comp. (Incl. Item's 23 thru 29)
35	19990JM	+	Flexible Hose
	19990AG		Flexible Hose
36	16158		Detergent Tube
37	15845		Ball Pivot Stud
38	15532	+	Valve Control Rod
39	15533	+	Handle End Plug
40	18031	+	Control Cord Assem.
41	18714	+	Protector Tube
42	19880JM	+	Handle Tube
	31756011		Handle Tube - AX - F5300, F5300-060
43	163055	*	Terminal (2)
44	46363281		Attach. Cord
45	48969	*	Wire Nut (2)
46	19462		Nut
47	15541	+	Insulating Tube
48	15539AW	+	Screw (Separator Cover)
49	15538	+	Screw (Handle)
50	27666702	*	Terminal (3)
51	15536	+*	Control Lever Pin
52	43131050		Control Lever
	43131051		Control Lever - AG - F5300, F5300-060
53	15838		Switch
54	38421009		Switch Knob - ACC
55	12955	*	Screw (2)
56	21481464	+	Screw (2)
57	15830	*	Insulator
58	15601	+*	Terminal Insulator
59	48663208		Handle Grip - R.H. & L.H. (JX)
	48663123		Handle Grip - R.H. & L.H. (AAP) - F5047
	48663208		Handle Grip - R.H. & L.H. (AG) - F5300, F5300-060
60	15565JM	+	Dispenser Cup
61	15562	+*	Rivet
	46363338		Attachment Cord Assem.

Gear Housing - P. 50
Motor - P. 52
Accessories - P. 54

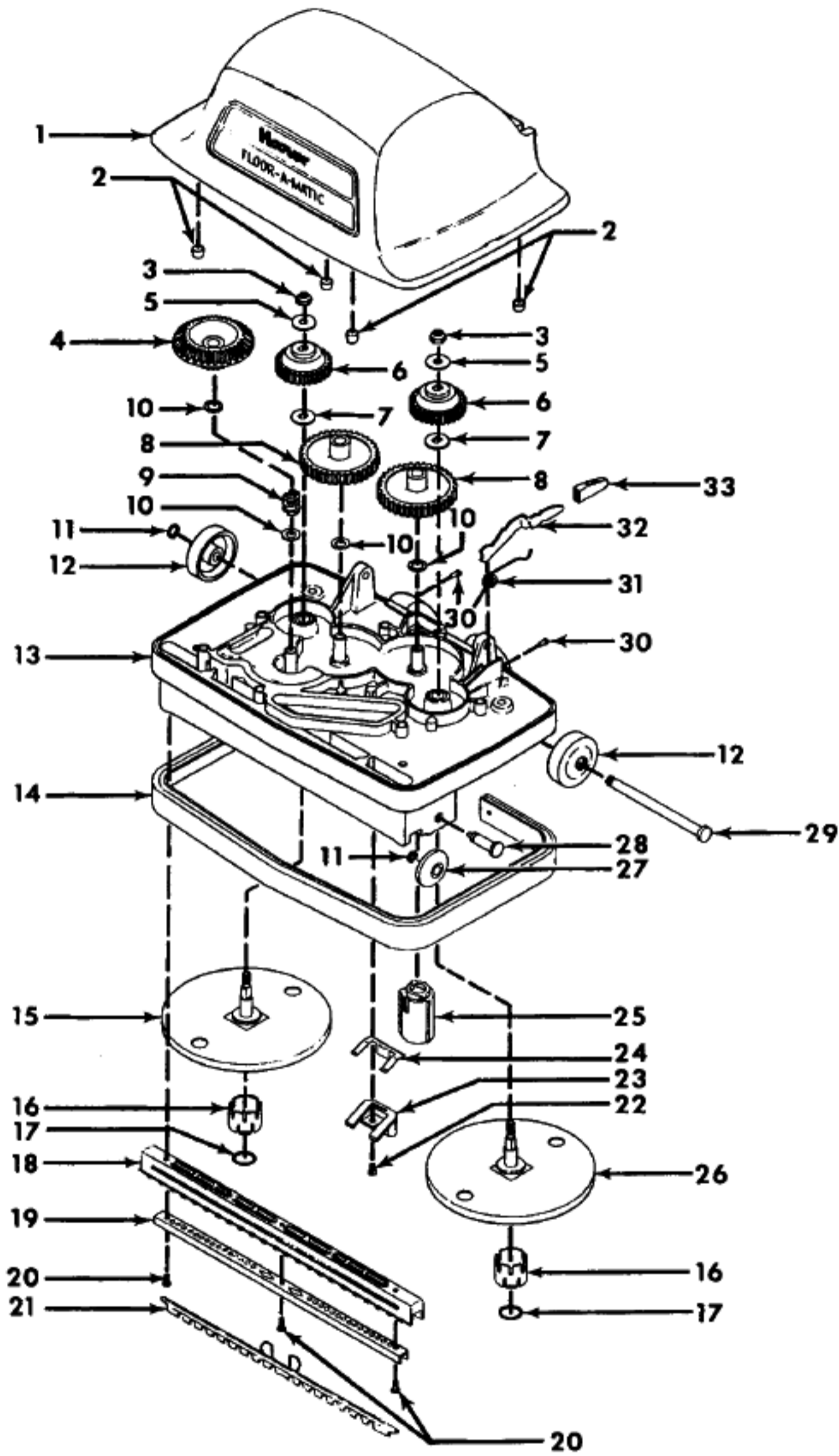

Gear Housing

Models F5019, F5047, F5300, F5300-060

Ref.	Part Description	No.	No.	Ref.	Part Description	No.	No.
1	42271065 42271069 42271077	Hood - JX Hood - AAM - F5047 Hood - w/ nameplate - AG - F5300, F5300-060		20	163598	*	Screw (3)
	52313041	Hood Nameplate - F5300, F5300-060		21	162193		Filter Bar
2	16125AY	+ Capsert (4)		22	18001	*	Screw
3	15887	* Hex Nut (2)		23	15911		Brush Stop
4	161028BZ	Bevel Gear		24	18331		Brush Stop Spring
5	21312714	* Washer (2)		25	15603AG		Foamer Nozzle
6	161328	Brush Shaft Gear (2)		26	18255		Brush Shaft & Inertia Plate - L.H.
7	15889	+* Washer (2)		27	38521002		Front Wheel (2)
8	15745BZ	Idler Gear (2)		28	15505	+	Front Wheel Shaft (2)
9	40404064	Compression Spring		29	40404082		Rear Wheel Shaft
10	21312715	+* Washer (4)		30	49571AY	+*	Rivet (2)
11	15836	* Lock Ring (4)		31	16206AY		Handle Control Lever Spring
12	32175004 32175003	+ Caster Wheel (2) Caster Wheel (2)		32	15910AY		Handle Control Lever
13	164199AG 42273014	+ Gear Housing Gear Housing		33	34207AG		Foot Pad
14	36231118 36231119	Furniture Guard + Furniture Guard - ACN - F5300, F5300-060			38426003		Foot Pad - ACC - F5300, F5300-060
15	18254	Brush Shaft & Inertia Plate - R.H.			16297	+*	Screw - Self Tapping (Hood Attach.)
16	15841BZ	Brush Carrier (2)					
17	15534	"O" Ring (2)					
18	15808 39512007	Squeegee Blade - AG Squeegee Blade - ACC - F5300, F5300-060					
19	162091GA	Squeegee Blade Bracket					

Handle & Tank - P. 48
Motor - P. 52
Accessories - P. 54

Brushes & Pads

Models F3119, F4143, F4251, F4251-060, F4255, F4255-040, F4300, F4323, F5019, F5047, F5300, F5300-060

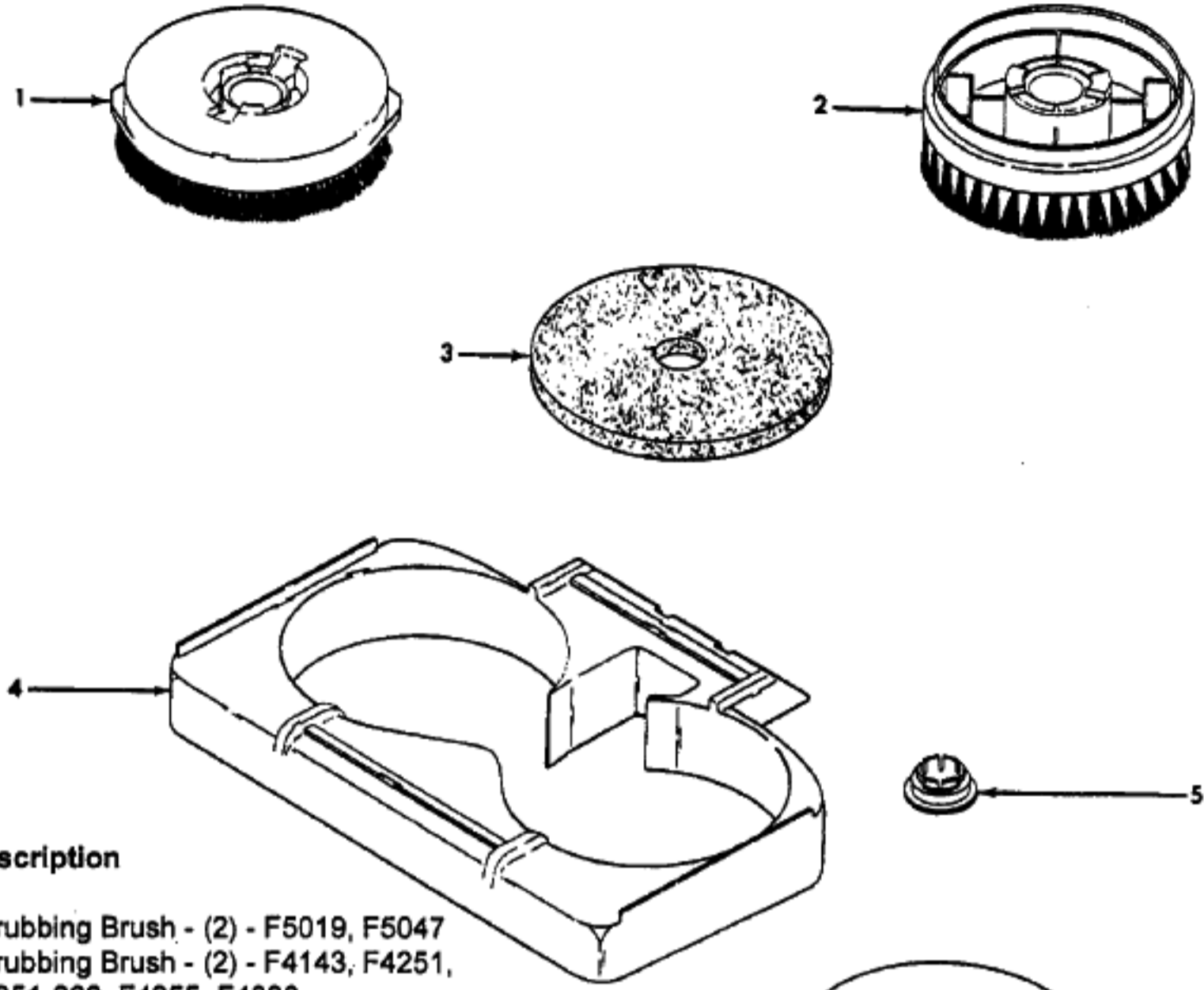

Ref. No.	Part No.	Description
1	48436008 48436045	Scrubbing Brush - (2) - F5019, F5047 Scrubbing Brush - (2) - F4143, F4251, F4251-060, F4255, F4323
2	48436047 15636	Scrubbing Brush - (2) - F5300, F5300-060 Rug Shampoo Brush - (2) - F5019, F5047, F5300, F5300-060
3	48437005 18362	Rug Shampoo Brush - (2) - F3119, F4143, F4251, F4251-060, F4255, F4300, F4323 Cleaning-Waxing Pads - Pair - F4143, F4251, F4251-060, F4255, F4300, F4323, F5019, F5047, F5300, F5300-060
4	13195 16543JX 37275005 37275018	Cleaning-Waxing Pads - Pair - F4255-040 + Rug Shampoo Attach. Rug Shampoo Attach. - AAM - F5019, F5047 Rug Shampoo Attach. - AG - F5300, F5300-060
5	37275018 15844	Pad Fastener - (2) - F4143, F4251, F4251-060, F4255, F4300, F4323, F5019, F5047, F5300, F5300-060
6	32172004 18360	Pad Fastener - (2) - F4255-040 High Lustre Pads - Pair - F4255, F5019, F5047, F5300, F5300-060 (2pr.)
7	13197 18361	High Lustre Pads - Pair - F4255-040 Felt Buffing Pads - Pair - F4143, F4251, F4251-060, F4300, F5019, F5047, F5300, F5300-060 (2pr.)
8	48432014 48483003 35613 48436045	Felt Buffing Pads - Pair - F4255-040 Soft Cloth Pads - F4300, F5300, F5300-060 (2pr.) Polishing Brush - F4255-040 Scrubbing Brush - F4300

ITEMS NOT ILLUSTRATED

40301200	Rug and Carpet Shampoo - 32 Oz. (Optional) - F5300, F5300-060
57333001	Rug and Carpet Shampoo - 16 Oz. - F4300, F5300, F5300-060
40303032	Bare Floor Solution - 32 Oz. - F4300, F5300, F5300-060

