

# SHARP SERVICE MANUAL

S1202R310FPW/

## MICROWAVE OVEN

MODELS **R-310FK**  
**R-310FW**

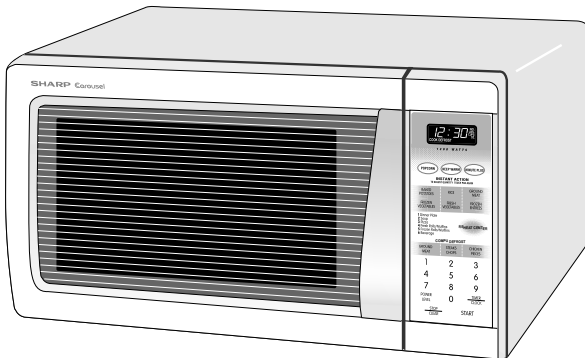

In the interest of user-safety the oven should be restored to its original condition and only parts identical to those specified should be used.

**WARNING TO SERVICE PERSONNEL:** Microwave ovens contain circuitry capable of producing very high voltage and current, contact with following parts may result in a severe, possibly fatal, electrical shock. (High Voltage Capacitor, High Voltage Power Transformer, Magnetron, High Voltage Rectifier Assembly, High Voltage Harness etc..)

### TABLE OF CONTENTS

	Page
PRECAUTIONS TO BE OBSERVED BEFORE AND DURING SERVICING TO AVOID POSSIBLE EXPOSURE TO EXCESSIVE MICROWAVE ENERGY .....	INSIDE FRONT COVER
BEFORE SERVICING .....	INSIDE FRONT COVER
WARNING TO SERVICE PERSONNEL .....	1
MICROWAVE MEASUREMENT PROCEDURE .....	2
FOREWORD AND WARNING .....	3
PRODUCT SPECIFICATIONS .....	4
GENERAL INFORMATION .....	4
OPERATION .....	6
TROUBLESHOOTING GUIDE .....	9
TEST PROCEDURE .....	10
TOUCH CONTROL PANEL .....	18
COMPONENT REPLACEMENT AND ADJUSTMENT PROCEDURE .....	22
PICTORIAL DIAGRAM .....	28
POWER UNIT CIRCUIT .....	29
CPU UNIT CIRCUIT .....	30
PRINTED WIRING BOARD .....	31
PARTS LIST .....	32
PACKING AND ACCESSORIES .....	36

## SHARP CORPORATION

This document has been published to be used for after sales service only.

The contents are subject to change without notice.

## **PRECAUTIONS TO BE OBSERVED BEFORE AND DURING SERVICING TO AVOID POSSIBLE EXPOSURE TO EXCESSIVE MICROWAVE ENERGY**

- (a) Do not operate or allow the oven to be operated with the door open.
- (b) Make the following safety checks on all ovens to be serviced before activating the magnetron or other microwave source, and make repairs as necessary: (1) interlock operation, (2) proper door closing, (3) seal and sealing surfaces (arcing, wear, and other damage), (4) damage to or loosening of hinges and latches, (5) evidence of dropping or abuse.
- (c) Before turning on microwave power for any service test or inspection within the microwave generating compartments, check the magnetron, wave guide or transmission line, and cavity for proper alignment, integrity, and connections.
- (d) Any defective or misadjusted components in the interlock, monitor, door seal, and microwave generation and transmission systems shall be repaired, replaced, or adjusted by procedures described in this manual before the oven is released to the owner.
- (e) A microwave leakage check to verify compliance with the Federal Performance Standard should be performed on each oven prior to release to the owner.

## **BEFORE SERVICING**

Before servicing an operative unit, perform a microwave emission check as per the Microwave Measurement Procedure outlined in this service manual.

If microwave emissions level is in excess of the specified limit, contact SHARP ELECTRONICS CORPORATION immediately @1-800-237-4277.

If the unit operates with the door open, service person should 1) tell the user not to operate the oven and 2) contact SHARP ELECTRONICS CORPORATION and Food and Drug Administration's Center for Devices and Radiological Health immediately.

Service personnel should inform SHARP ELECTRONICS CORPORATION of any certified unit found with emissions in excess of  $4\text{mW}/\text{cm}^2$ . The owner of the unit should be instructed not to use the unit until the oven has been brought into compliance.

# WARNING TO SERVICE PERSONNEL

Microwave ovens contain circuitry capable of producing very high voltage and current, contact with following parts may result in a severe, possibly fatal, electrical shock.

(Example)

High Voltage Capacitor, High Voltage Power Transformer, Magnetron, High Voltage Rectifier Assembly, High Voltage Harness etc..

Read the Service Manual carefully and follow all instructions.

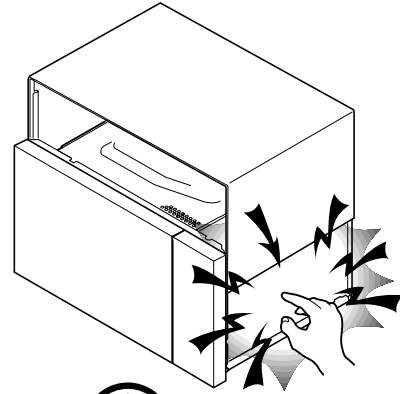

**Don't Touch !  
Danger High Voltage**

## Before Servicing

1. Disconnect the power supply cord , and then remove outer case.
2. Open the door and block it open.
3. Discharge high voltage capacitor.

**WARNING: RISK OF ELECTRIC SHOCK.  
DISCHARGE THE HIGH-VOLTAGE  
CAPACITOR BEFORE SERVICING.**

The high-voltage capacitor remains charged about 60 seconds after the oven has been switched off. Wait for 60 seconds and then short-circuit the connection of the high-voltage capacitor (that is the connecting lead of the high-voltage rectifier) against the chassis with the use of an insulated screwdriver.

Whenever troubleshooting is performed the power supply must be disconnected. It may, in some cases, be necessary to connect the power supply after the outer case has been removed, in this event,

1. Disconnect the power supply cord, and then remove outer case.
2. Open the door and block it open.
3. Discharge high voltage capacitor.
4. Disconnect the leads to the primary of the power transformer.
5. Ensure that the leads remain isolated from other components and oven chassis by using insulation tape.
6. After that procedure, reconnect the power supply cord.

## When the testing is completed,

1. Disconnect the power supply cord, and then remove outer case.
2. Open the door and block it open.
3. Discharge high voltage capacitor.
4. Reconnect the leads to the primary of the power transformer.
5. Reinstall the outer case (cabinet).
6. Reconnect the power supply cord after the outer case is installed.
7. Run the oven and check all functions.

## After repairing

1. Reconnect all leads removed from components during testing.
2. Reinstall the outer case (cabinet).
3. Reconnect the power supply cord after the outer case is installed.
4. Run the oven and check all functions.

Microwave ovens should not be run empty. To test for the presence of microwave energy within a cavity, place a cup of cold water on the oven turntable, close the door and set the power to HIGH and set the microwave timer for two (2) minutes. When the two minutes has elapsed (timer at zero) carefully check that the water is now hot. If the water remains cold carry out **Before Servicing** procedure and re-examine the connections to the component being tested.

When all service work is completed and the oven is fully assembled, the microwave power output should be checked and a microwave leakage test should be carried out.

## MICROWAVE MEASUREMENT PROCEDURE

### A. Requirements:

- 1) Microwave leakage limit (Power density limit): The power density of microwave radiation emitted by a microwave oven should not exceed  $1\text{mW}/\text{cm}^2$  at any point 5cm or more from the external surface of the oven, measured prior to acquisition by a purchaser, and thereafter (through the useful life of the oven),  $5\text{mW}/\text{cm}^2$  at any point 5cm or more from the external surface of the oven.
- 2) Safety interlock switches:  
Primary interlock relay and door sensing switch shall prevent microwave radiation emission in excess of the requirement as above mentioned, secondary interlock switch shall prevent microwave radiation emission in excess of  $5\text{mW}/\text{cm}^2$  at any point 5cm or more from the external surface of the oven.

### B. Preparation for testing:

**Before beginning the actual measurement of leakage, proceed as follows:**

- 1) Make sure that the actual instrument is operating normally as specified in its instruction booklet.

Important:

Survey instruments that comply with the requirement for instrumentation as prescribed by the performance standard for microwave ovens, 21 CFR 1030.10(c)(3)(i), must be used for testing.

- 2) Place the oven tray in the oven cavity.
- 3) Place the load of  $275\pm 15\text{ ml}$  (9.8 oz) of tap water initially at  $20\pm 5^\circ\text{C}$  ( $68^\circ\text{F}$ ) in the center of the oven cavity.  
The water container shall be a low form of 600 ml (20 oz) beaker with an inside diameter of approx. 8.5 cm (3-1/2 in.) and made of an electrically nonconductive material such as glass or plastic.  
The placing of this standard load in the oven is important not only to protect the oven, but also to insure that any leakage is measured accurately.
- 4) Set the cooking control on Full Power Cooking Mode.
- 5) Close the door and select a cook cycle of several minutes. If the water begins to boil before the survey is completed, replace it with 275 ml of cool water.

### C. Leakage test:

Closed-door leakage test (microwave measurement)

- 1) Grasp the probe of the survey instrument and hold it perpendicular to the gap between the door and the body of the oven.
- 2) Move the probe slowly, not faster than 1 in./sec. (2.5 cm/sec.) along the gap, watching for the maximum indication on the meter.
- 3) Check for leakage at the door screen, sheet metal seams and other accessible positions where the continuity of the metal has been breached (eg., around the switches, indicator, and vents).  
While testing for leakage around the door pull the door away from the front of the oven as far as is permitted by the closed latch assembly.
- 4) Measure carefully at the point of highest leakage and make sure that the highest leakage is no greater than  $4\text{mW}/\text{cm}^2$ .

NOTE: After servicing, record data on service invoice and microwave leakage report.

# SERVICE MANUAL

## SHARP

### MICROWAVE OVEN

#### R-310FK/ R-310FW

#### FOREWORD

This Manual has been prepared to provide Sharp Electronics Corp. Service Personnel with Operation and Service Information for the SHARP MICROWAVE OVENS, R-310FK and R-310FW.

It is recommended that service personnel carefully study the entire text of this manual so that they will be qualified to render satisfactory customer service.

Check the interlock switches and the door seal carefully. Special attention should be given to avoid electrical shock and microwave radiation hazard.

#### WARNING

Never operate the oven until the following points are ensured.

- (A) The door is tightly closed.
- (B) The door brackets and hinges are not defective.
- (C) The door packing is not damaged.
- (D) The door is not deformed or warped.
- (E) There is no other visible damage with the oven.

Servicing and repair work must be carried out only by trained service personnel.

#### DANGER

**Certain initial parts are intentionally not grounded and present a risk of electrical shock only during servicing. Service personnel - Do not contact the following parts while the appliance is energized;**

**High Voltage Capacitor, Power Transformer, Magnetron, High Voltage Rectifier Assembly, High Voltage Harness; If provided, Vent Hood, Fan assembly, Cooling Fan Motor.**

All the parts marked "\*" on parts list are used at voltages more than 250V.

Removal of the outer wrap gives access to voltage above 250V.

All the parts marked "Δ" on parts list may cause undue microwave exposure, by themselves, or when they are damaged, loosened or removed.

PRODUCT DESCRIPTION

GENERAL INFORMATION

OPERATION

TROUBLESHOOTING GUIDE AND  
TEST PROCEDURE

TOUCH CONTROL PANEL

COMPONENT REPLACEMENT  
AND ADJUSTMENT PROCEDURE

WIRING DIAGRAM

PARTS LIST

SHARP ELECTRONICS CORPORATION

SHARP PLAZA, MAHWAH,  
NEW JERSEY 07430-2135

## SPECIFICATION

ITEM	DESCRIPTION
Power Requirements	120 Volts / 14.2 Amperes 60 Hertz Single phase, 3 wire grounded
Power Output	1200 watts (IEC TEST PROCEDURE) Operating frequency of 2450MHz
Case Dimensions	Width 20-1/2" Height 11-7/8" Depth 17-1/8"
Cooking Cavity Dimensions  1.2 Cubic Feet	Width 14-3/4" Height 8-3/4" Depth 15-3/4"
Control Complement	Touch Control System Clock ( 1:00 - 12:59 ) Timer (0 - 99 min. 99 seconds) Microwave Power for Variable Cooking Repetition Rate; P-HI ..... Full power throughout the cooking time P-90 ..... approx. 90% of Full Power P-80 ..... approx. 80% of Full Power P-70 ..... approx. 70% of Full Power P-60 ..... approx. 60% of Full Power P-50 ..... approx. 50% of Full Power P-40 ..... approx. 40% of Full Power P-30 ..... approx. 30% of Full Power P-20 ..... approx. 20% of Full Power P-10 ..... approx. 10% of Full Power P-0 ..... No power throughout the cooking time POPCORN pad, KEEP WARM pad, MINUTE PLUS pad INSTANT ACTION pads, REHEAT CENTER pad COMPU DEFROST pads, Number selection pads POWER LEVEL pad, TIMER/CLOCK pad STOP/CLEAR pad, START pad
Oven Cavity Light	Yes
Safety Standard	UL Listed                      FCC Authorized DHHS Rules, CFR, Title 21, Chapter 1, Subchapter J

## GENERAL INFORMATION

### GROUNDING INSTRUCTIONS

This oven is equipped with a three prong grounding plug. It must be plugged into a wall receptacle that is properly installed and grounded in accordance with the National Electrical Code and local codes and ordinances.

In the event of an electrical short circuit, grounding reduces the risk of electric shock by providing an escape wire for the electric current.

**WARNING: Improper use of the grounding plug can result in a risk of electric shock.**

#### Electrical Requirements

The electrical requirements are a 120 volt 60 Hz, AC only,

15 or 20 amp. fused electrical supply. It is recommended that a separate circuit serving only this appliance be provided. When installing this appliance, observe all applicable codes and ordinances.

A short power-supply cord is provided to reduce risks of becoming entangled in or tripping over a longer cord.

Where a two-pronged wall-receptacle is encountered, it is the personal responsibility and obligation of the customer to

contact a qualified electrician and have it replaced with a properly grounded three-pronged wall receptacle or have a grounding adapter properly grounded and polarized. If the extension cord must be used, it should be a 3-wire, 15 amp. or higher rated cord. Do not drape over a countertop or table where it can be pulled on by children or tripped over accidentally.

**CAUTION: DO NOT UNDER ANY CIRCUMSTANCES CUT OR REMOVE THE ROUND GROUNDING PRONG FROM THIS PLUG.**

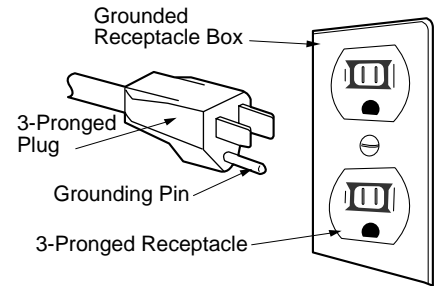

**OVEN DIAGRAM**

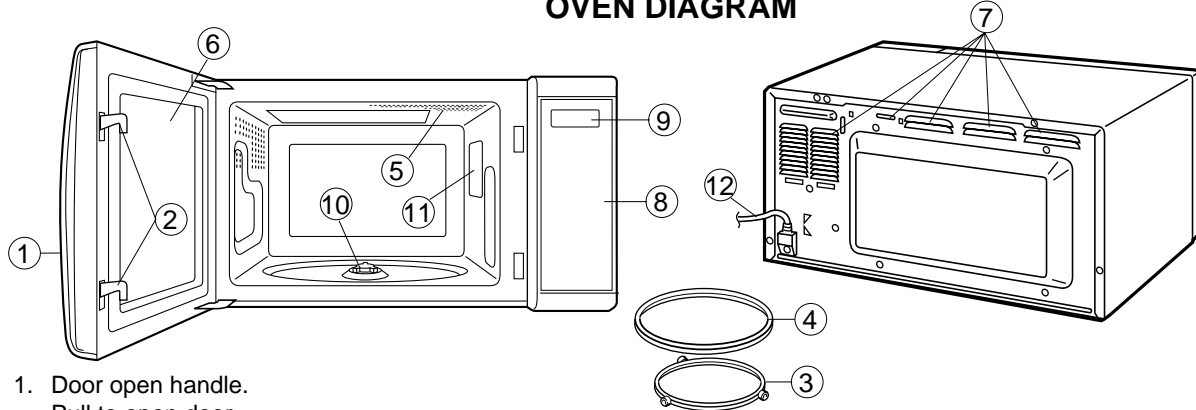

- 1. Door open handle. Pull to open door.
- 2. Door latches. The oven will not operate unless the door is securely closed.
- 3. Removable turntable support.
- 4. Removable turntable. The turntable will rotate clockwise or counterclockwise.
- 5. Oven lamp. It will light when oven is operating or door is opened.
- 6. Oven door with see-through window.
- 7. Ventilation openings. (Rear)
- 8. Auto-Touch control panel.
- 9. Time display: Digital display, 99 minutes 99 seconds.
- 10. Coupling.
- 11. Wave guide cover.
- 12. Power supply cord

**TOUCH CONTROL PANEL**

12:30 NO. LBS. CUPS OZ.  
COOK DEFROST

1200 WATTS

POPCORN
KEEP WARM
MINUTE PLUS

**INSTANT ACTION**  
TO ADJUST QUANTITY TOUCH PAD AGAIN

BAKED POTATOES	RICE	GROUND MEAT
FROZEN VEGETABLES	FRESH VEGETABLES	FROZEN ENTREES

- 1 Dinner Plate
- 2 Soup
- 3 Pizza
- 4 Fresh Rolls/Muffins
- 5 Frozen Rolls/Muffins
- 6 Beverage

**REHEAT CENTER**

**COMPU DEFROST**

GROUND MEAT	STEAKS CHOPS	CHICKEN PIECES
1	2	3
4	5	6
7	8	9
POWER LEVEL	0	TIMER CLOCK
STOP CLEAR	START	

**NOTE:**

Some one-touch cooking features such as "MINUTE PLUS" are disabled after three minutes when the oven is not in use. These features are automatically enabled when the door is opened and closed or the STOP/ CLEAR pad is pressed.



## OPERATION

### DESCRIPTION OF OPERATING SEQUENCE

The following is a description of component functions during oven operation.

#### OFF CONDITION

Closing the door activates the door sensing switch and secondary interlock switch. (In this condition, the monitor switch contacts are opened.)

When oven is plugged in, 120 volts A.C. is supplied to the control unit. (Figure O-1).

- The display will show flashing "88 : 88".  
To set any program or set the clock, you must first touch the STOP/CLEAR pad. The display will clear, and " : " will appear.

#### COOKING CONDITION

Program desired cooking time by touching the NUMBER pads. Program the power level by touching the POWER LEVEL pad.

When the START pad is touched, the following operations occur:

- The contacts of relays are closed and components connected to the relays are turned on as follows. (For details, refer to Figure O-2)

RELAY	CONNECTED COMPONENTS
RY-1	oven lamp/turntable motor/fan motor
RY-2	power transformer

- 120 volts A.C. is supplied to the primary winding of the power transformer and is converted to about 3.3 volts A.C. output on the filament winding, and approximately 2355 volts A.C. on the high voltage winding.
- The filament winding voltage heats the magnetron filament and the H.V. winding voltage is sent to a voltage doubler circuit.
- The microwave energy produced by the magnetron is channelled through the waveguide into the cavity feed-box, and then into the cavity where the food is placed to be cooked.
- Upon completion of the cooking time, the power transformer, oven lamp, etc. are turned off, and the generation of microwave energy is stopped. The oven will revert to the OFF condition.
- When the door is opened during a cook cycle, the monitor switch, door sensing switch, secondary interlock switch, relay (RY1) and primary interlock relay are activated with the following results. The circuits to the turntable motor, the cooling fan motor, and the high voltage components are de-energized, the oven lamp remains on, and the digital read-out displays the time still remaining in the cook cycle when the door was opened.
- The monitor switch electrically monitors the operation of the secondary interlock switch and primary interlock

relay and is mechanically associated with the door so that it will function in the following sequence.

- When the door opens from the closed position, the primary interlock relay (RY2) and secondary interlock switch open their contacts. And contacts of the relay (RY1) remains closed. Then the monitor switch contacts close.
- When the door is closed from the open position, the monitor switch contacts open first. Then the contacts of the secondary interlock switch and door sensing switch close. And contacts of the relay (RY1) open.

If the secondary interlock switch and primary interlock relay (RY2) fail with the contacts closed when the door is opened, the closing of the monitor switch contacts will form a short circuit through the monitor fuse, secondary interlock switch, relay (RY1) and primary interlock relay (RY2), causing the monitor fuse to blow.

#### POWER LEVEL P-0 TO P-90 COOKING

When Variable Cooking Power is programmed, the 120 volts A.C. is supplied to the power transformer intermittently through the contacts of relay (RY-2) which is operated by the control unit within a 32 second time base. Microwave power operation is as follows:

VARI-MODE	ON TIME	OFF TIME
P-HI (100% power)	32 sec.	0 sec.
P-90 (approx. 90% power)	30 sec.	2 sec.
P-80 (approx. 80% power)	26 sec.	6 sec.
P-70 (approx. 70% power)	24 sec.	8 sec.
P-60 (approx. 60% power)	22 sec.	10 sec.
P-50 (approx. 50% power)	18 sec.	14 sec.
P-40 (approx. 40% power)	16 sec.	16 sec.
P-30 (approx. 30% power)	12 sec.	20 sec.
P-20 (approx. 20% power)	8 sec.	24 sec.
P-10 (approx. 10% power)	6 sec.	26 sec.
P-0 (approx. 0% power)	0 sec.	32 sec.

Note: The ON/OFF time ratio does not correspond with the percentage of microwave power, because approx. 3 seconds are needed for heating of the magnetron filament.



**SCHMATIC**  
NOTE: CONDITION OF OVEN  
1. DOOR CLOSED  
2. CLOCK APPEARS ON DISPLAY

NOTE: "★" indicates components with potential above 250V.

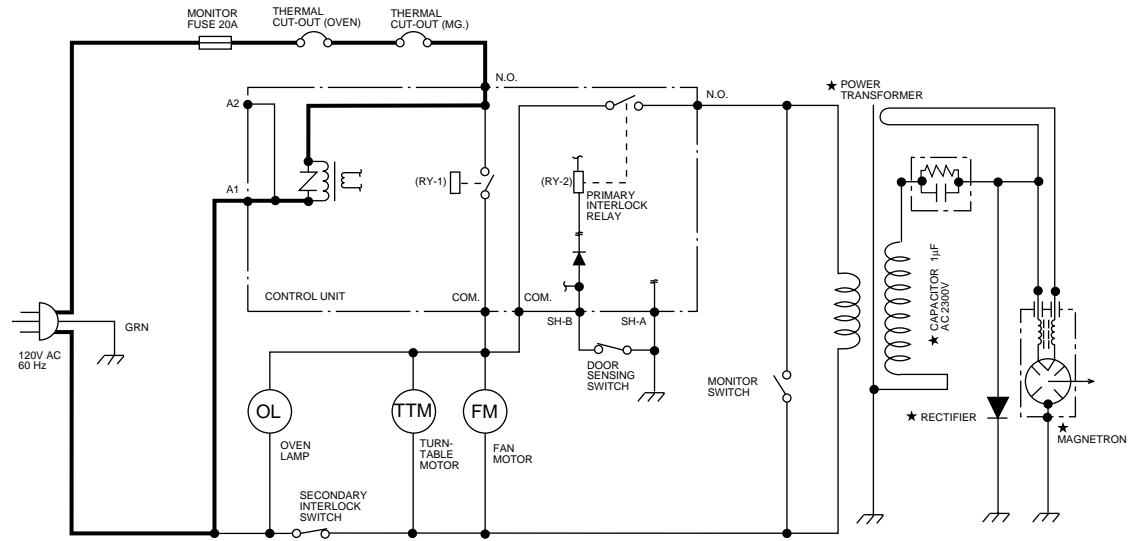

**Figure O-1. Oven Schematic-Off Condition**

**SCHMATIC**  
NOTE: CONDITION OF OVEN  
1. DOOR CLOSED  
2. COOKING TIME PROGRAMMED  
3. VARIABLE COOKING CONTROL "HIGH"  
4. "START" PAD TOUCHED

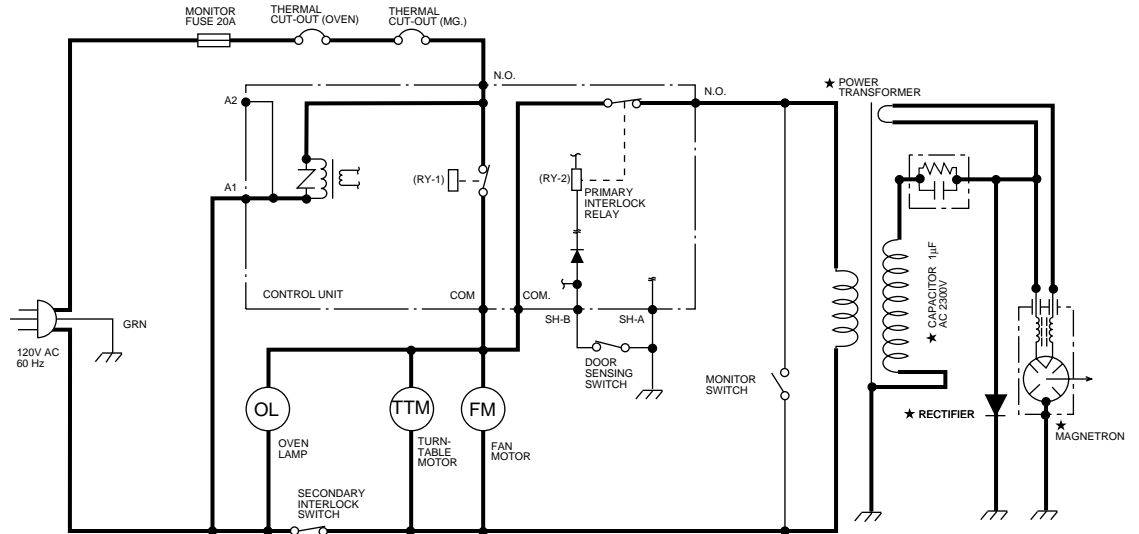

**Figure O-2. Oven Schematic-Cooking Condition**

## DESCRIPTION AND FUNCTION OF COMPONENTS

### DOOR OPEN MECHANISM

The door is opened by pulling the door. Refer to the Figure D-1.

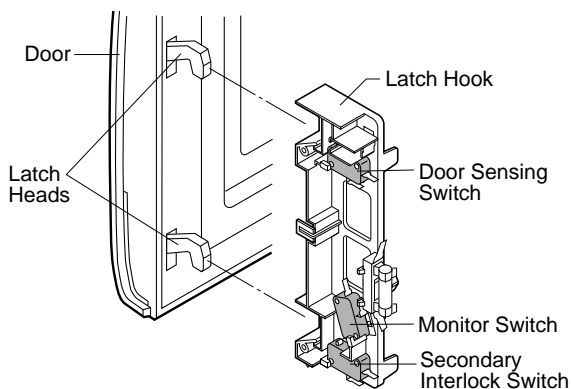

Figure D-1. Door Open Mechanism

### DOOR SENSING AND SECONDARY INTERLOCK SWITCHES

The secondary interlock switch is mounted in the lower position of the latch hook and the door sensing switch in the primary interlock system is mounted in the upper position of the latch hook. They are activated by the latch heads on the door. When the door is opened, the switches interrupt the power to all high voltage components. A cook cycle cannot take place until the door is firmly closed thereby activating both interlock switches. The primary interlock system consists of the door sensing switch and primary interlock relay located on the control circuit board.

### MONITOR SWITCH

The monitor switch is activated (the contacts opened) by the latch head on the door while the door is closed. The switch is intended to render the oven inoperative, by means of blowing the monitor fuse, when the contacts of the primary interlock relay (RY2) and secondary interlock switch fail to open when the door is opened.

#### Functions:

1. When the door is opened, the monitor switch contact close (to the ON condition) due to their being normally closed. At this time the primary interlock relay (RY2) and secondary interlock switch are in the OFF condition (contacts open) due to their being normally open contact switches.
2. As the door goes to a closed position, the monitor switch contacts are first opened and then the door sensing switch and the secondary interlock switch contacts close. (On opening the door, each of these switches operate inversely.)
3. If the door is opened, and the primary interlock relay (RY2) and secondary interlock switch contacts fail to open, the monitor fuse blows simultaneously with closing of the monitor switch contacts.

**CAUTION:** BEFORE REPLACING A BLOWN MONITOR FUSE TEST THE DOOR SENSING SWITCH, PRIMARY INTERLOCK RELAY (RY2), RELAY (RY1), SECONDARY INTERLOCK SWITCH AND MONITOR SWITCH FOR PROPER OPERATION. (REFER TO CHAPTER "TEST PROCEDURE").

**NOTE:** MONITOR FUSE AND MONITOR SWITCH ARE REPLACED AS AN ASSEMBLY.

### TURNTABLE MOTOR

The turntable motor rotates the turntable located on the bottom of the oven cavity, so that the foods on the turntable cook evenly during cooking. The turntable may turn in either direction.

### COOLING FAN MOTOR

The cooling fan motor drives a blade which draws external cool air. This cool air is directed through the air vents surrounding the magnetron and cools the magnetron. This air is channelled through the oven cavity to remove steam and vapors given off from the heating foods. It is then exhausted through the exhausting air vents at the oven cavity.

### MONITOR FUSE

1. The monitor fuse blows when the contacts (COM-NO) of the primary interlock relay (RY2) and secondary interlock switch remain closed with the oven door open and when the monitor switch closes.
2. If the wire harness or electrical components are short-circuited, this monitor fuse blows to prevent an electric shock or fire hazard.

### OVEN THERMAL CUT-OUT

The thermal cut-out, located on the top of the oven cavity, is designed to prevent damage to the oven by fire. If the food load is overcooked, by either error in cook time or defect in the control unit, the thermal cut-out will open. Under normal operation, the oven thermal cut-out remains closed. However, when abnormally high temperatures are reached within the oven cavity, the oven thermal cut-out will open at 257°F(125°C), causing the oven to shut down.

### MAGNETRON THERMAL CUT-OUT

The thermal cut-out located near the magnetron is designed to prevent damage to the magnetron if an over heated condition develops in the tube due to cooling fan failure, obstructed air guide, dirty or blocked air intake, etc. Under normal operation, the thermal cut-out remains closed. However, when abnormally high temperatures are reached within the magnetron, the thermal cut-out will open at 293°F(145°C) causing the oven to shut down.

## TROUBLESHOOTING GUIDE

**Never touch any part in the circuit with your hand or an uninsulated tool while the power supply is connected.**

When troubleshooting the microwave oven, it is helpful to follow the Sequence of Operation in performing the checks. Many of the possible causes of trouble will require that a specific test be performed. These tests are given a procedure letter which will be found in the "Test Procedure" section.

**IMPORTANT:** If the oven becomes inoperative because of a blown monitor fuse, check the monitor switch, relay (RY1) primary interlock relay (RY2), door sensing switch and secondary interlock switch before replacing the monitor fuse. If the monitor fuse is replaced, the monitor switch must also be replaced. Use part FFS-BA021WRK0 as an assembly.

**IMPORTANT:** Whenever troubleshooting is performed with the power supply cord disconnected. It may, in some cases, be necessary to connect the power supply cord after the outer case has been removed, in this event,

1. Disconnect the power supply cord, and then remove outer case.
2. Open the door and block it open.
3. Discharge high voltage capacitor.
4. Disconnect the leads to the primary of the power transformer.
5. Ensure that the leads remain isolated from other components and oven chassis by using insulation tape.
6. After that procedure, reconnect the power supply cord.

### **When the testing is completed**

1. Disconnect the power supply cord, and then remove outer case.
2. Open the door and block it open.
3. Discharge high voltage capacitor.
4. Reconnect all leads removed from components during testing.
5. Reinstall the outer case (cabinet).
6. Reconnect the power supply cord after the outer case is installed.
7. Run the oven and check all functions.

CK = Check / RE = Replace

CONDITION	TEST PROCEDURE  POSSIBLE CAUSE AND DEFECTIVE PARTS  PROBLEM	RE	RE	A	B	C	D	E	F	F	G	H	RE	RE	CK	I	CK	CK	J	K	L	M	
		SHORT IN POWER CORD	SHORT OR OPENED WIRING	MAGNETRON	POWER TRANSFORMER	H.V. RECTIFIER ASSEMBLY	HIGH VOLTAGE CAPACITOR	THERMAL CUT-OUT	PRIMARY INTERLOCK SYSTEM	SECONDARY INTERLOCK SWITCH	MONITOR SWITCH	MONITOR FUSE	OVEN LAMP OR SOCKET	COOLING FAN MOTOR	TURNTABLE MOTOR	TOUCH CONTROL PANEL	WRONG OPERATION	LOW VOLTAGE	DIRTY OVEN CAVITY	KEY UNIT	RELAY (RY1)	COMPU DEFROST	FOIL PATTERN ON PWB.
OFF CONDITION	Home fuse or circuit breaker blows when power cord is plugged into wall receptacle	<input type="radio"/>	<input type="radio"/>																				
	Monitor fuse blows when power cord is plugged into wall receptacle.		<input type="radio"/>						<input type="radio"/>	<input type="radio"/>	<input type="radio"/>					<input type="radio"/>							
	All letters and indicators do not appear in display when power cord is first plugged into wall outlet.		<input type="radio"/>					<input type="radio"/>				<input type="radio"/>				<input type="radio"/>						<input type="radio"/>	
	Display does not operate properly when STOP/CLEAR key is touched. (Buzzer should sound and ":" or time of day should appear in display.)		<input type="radio"/>							<input type="radio"/>						<input type="radio"/>				<input type="radio"/>			
	Oven lamp does not light when door is opened.		<input type="radio"/>						<input type="radio"/>	<input type="radio"/>			<input type="radio"/>	<input type="radio"/>		<input type="radio"/>					<input type="radio"/>		
COOKING CONDITION	Oven lamp does not go out when door is closed.								<input type="radio"/>											<input type="radio"/>			
	Oven lamp lights but fan motor and turntable motor do not operate.		<input type="radio"/>							<input type="radio"/>			<input type="radio"/>	<input type="radio"/>									
	Oven does not go into cook cycle when START pad is touched		<input type="radio"/>						<input type="radio"/>	<input type="radio"/>						<input type="radio"/>	<input type="radio"/>		<input type="radio"/>	<input type="radio"/>			
	Oven seems to be operating but little or no heat is produced in oven load. (Food incompletely cooked or not cooked at all at end of cook cycle.)		<input type="radio"/>	<input type="radio"/>	<input type="radio"/>	<input type="radio"/>	<input type="radio"/>		<input type="radio"/>							<input type="radio"/>	<input type="radio"/>						
	Oven goes into a cook cycle but extremely uneven heating is produced in oven load (food).		<input type="radio"/>											<input type="radio"/>	<input type="radio"/>	<input type="radio"/>	<input type="radio"/>						
	Oven does not cook properly when programmed for Cooking Power P-50 mode. (Operates properly on Cooking Power P-HI (HIGH) mode.)									<input type="radio"/>							<input type="radio"/>						
	Oven goes into COMPU DEFROST but food is not defrosted well.															<input type="radio"/>	<input type="radio"/>					<input type="radio"/>	

### TEST PROCEDURES

PROCEDURE LETTER	COMPONENT TEST
<b>A</b>	<b>MAGNETRON ASSEMBLY TEST</b>
	<ol style="list-style-type: none"> <li>1. Disconnect the power supply cord, and then remove outer case.</li> <li>2. Open the door and block it open.</li> <li>3. Discharge high voltage capacitor.</li> </ol>

## TEST PROCEDURES

PROCEDURE LETTER	COMPONENT TEST
	<ol style="list-style-type: none"> <li>4. To test for an open filament, isolate the magnetron from the high voltage circuit. A continuity check across the magnetron filament leads should indicate less than 1 ohm.</li> <li>5. To test for a shorted magnetron, connect the ohmmeter leads between the magnetron filament leads and chassis ground. This test should indicate an infinite resistance. If there is little or no resistance the magnetron is grounded and must be replaced.</li> <li>6. Reconnect all leads removed from components during testing.</li> <li>7. Reinstall the outer case (cabinet).</li> <li>8. Reconnect the power supply cord after the outer case is installed.</li> <li>9. Run the oven and check all functions.</li> </ol> <p><b>MICROWAVE OUTPUT POWER</b></p> <p>The following test procedure should be carried out with the microwave oven in a fully assembled condition (outer case fitted).</p> <p><b>HIGH VOLTAGES ARE PRESENT DURING THE COOK CYCLE, SO EXTREME CAUTION SHOULD BE OBSERVED.</b></p> <p>Power output of the magnetron can be measured by performing a water temperature rise test. This test should only be used if above tests do not indicate a faulty magnetron and there is no defect in the following components or wiring: silicon rectifier, high voltage capacitor and power transformer. This test will require a 16 ounce (453cc) measuring cup and an accurate mercury thermometer or thermocouple type temperature tester. For accurate results, the following procedure must be followed carefully:</p> <ol style="list-style-type: none"> <li>1. Fill the measuring cup with 16 oz. (453cc) of tap water and measure the temperature of the water with a thermometer or thermocouple temperature tester. Stir the thermometer or thermocouple through the water until the temperature stabilizes. Record the temperature of the water.</li> <li>2. Place the cup of water in the oven. Operate oven at POWER P-HI(HIGH) selecting more than 60 seconds cook time. Allow the water to heat for 60 seconds, measuring with a stop watch, second hand of a watch or the digital read-out countdown.</li> <li>3. Remove the cup from the oven and again measure the temperature, making sure to stir the thermometer or thermocouple through the water until the maximum temperature is recorded.</li> <li>4. Subtract the cold water temperature from the hot water temperature. The normal result should be 31.5 to 58.5°F(17.5 to 32.5°C) rise in temperature. If the water temperatures are accurately measured and tested for the required time period the test results will indicate if the magnetron tube has low power output (low rise in water temperature) which would extend cooking time or high power output (high rise in water temperature) which would reduce cooking time. Because cooking time can be adjusted to compensate for power output, the magnetron tube assembly should be replaced only if the water temperature rise test indicates a power output well beyond the normal limits. The test is only accurate if the power supply line voltage is 120 volts and the oven cavity is clean.</li> </ol>
<b>B</b>	<p><b>POWER TRANSFORMER TEST</b></p> <ol style="list-style-type: none"> <li>1. Disconnect the power supply cord, and then remove outer case.</li> <li>2. Open the door and block it open.</li> <li>3. Discharge high voltage capacitor.</li> <li>4. Disconnect the primary input terminals and measure the resistance of the transformer with an ohmmeter. Check for continuity of the coils with an ohmmeter. On the R x 1 scale, the resistance of the primary coil should be less than 1 ohm and the resistance of the high voltage coil should be approximately 89 ohms; the resistance of the filament coil should be less than 1 ohm.</li> <li>5. Reconnect all leads removed from components during testing.</li> <li>6. Reinstall the outer case (cabinet).</li> <li>7. Reconnect the power supply cord after the outer case is installed.</li> <li>8. Run the oven and check all functions.</li> </ol> <p>(HIGH VOLTAGES ARE PRESENT AT THE HIGH VOLTAGE TERMINAL, SO DO NOT ATTEMPT TO MEASURE THE FILAMENT AND HIGH VOLTAGE.)</p>

**TEST PROCEDURES**

<b>PROCEDURE LETTER</b>	<b>COMPONENT TEST</b>
<b>C</b>	<b><u>HIGH VOLTAGE RECTIFIER TEST</u></b> <ol style="list-style-type: none"><li>1. Disconnect the power supply cord, and then remove outer case.</li><li>2. Open the door and block it open.</li><li>3. Discharge high voltage capacitor.</li><li>4. Isolate the rectifier from the circuit. Using the highest ohm scale of the meter, read the resistance across the terminals and observe, reverse the leads to the rectifier terminals and observe meter reading. If a short is indicated in both directions, or if an infinite resistance is read in both directions, the rectifier is probably defective and should be replaced.</li><li>5. Reconnect all leads removed from components during testing.</li><li>6. Reinstall the outer case (cabinet).</li><li>7. Reconnect the power supply cord after the outer case is installed.</li><li>8. Run the oven and check all functions.</li></ol> <p><b>NOTE: Be sure to use an ohmmeter that will supply a forward bias voltage of more than 6.3 volts.</b></p>
<b>D</b>	<b><u>HIGH VOLTAGE CAPACITOR TEST</u></b> <ol style="list-style-type: none"><li>1. Disconnect the power supply cord, and then remove outer case.</li><li>2. Open the door and block it open.</li><li>3. Discharge high voltage capacitor.</li><li>4. If the capacitor is open, no high voltage will be available to the magnetron. Disconnect input leads and check for short or open between the terminals using an ohmmeter. Checking with a high ohm scale, if the high voltage capacitor is normal, the meter will indicate continuity for a short time and should indicate an open circuit once the capacitor is charged. If the above is not the case, check the capacitor with an ohmmeter to see if it is shorted between either of the terminals and case. If it is shorted, replace the capacitor.</li><li>5. Reconnect all leads removed from components during testing.</li><li>6. Reinstall the outer case (cabinet).</li><li>7. Reconnect the power supply cord after the outer case is installed.</li><li>8. Run the oven and check all functions.</li></ol>
<b>E</b>	<b><u>OVEN THERMAL CUT-OUT TEST</u></b> <ol style="list-style-type: none"><li>1. Disconnect the power supply cord, and then remove outer case.</li><li>2. Open the door and block it open.</li><li>3. Discharge high voltage capacitor.</li><li>4. A continuity check across the thermal cut-out terminals should indicate a closed circuit unless the temperature of the thermal cut-out reaches approximately 257°F(125°C). An open thermal cut-out indicates overheating of the oven, exchange the oven thermal cut-out and check inside of oven cavity and for improper setting of cooking time or operation of control unit. Check for restricted air flow through the vent holes of the oven cavity, especially the cooling fan and air guide.</li><li>5. Reconnect all leads removed from components during testing.</li><li>6. Reinstall the outer case (cabinet).</li><li>7. Reconnect the power supply cord after the outer case is installed.</li><li>8. Run the oven and check all functions.</li></ol> <b><u>MAGNETRON THERMAL CUT-OUT TEST</u></b> <ol style="list-style-type: none"><li>1. Disconnect the power supply cord, and then remove outer case.</li><li>2. Open the door and block it open.</li><li>3. Discharge high voltage capacitor.</li><li>4. A continuity check across the thermal cut-out terminals should indicate a closed circuit unless the temperature of the magnetron reaches approximately 293°F(145°C). An open thermal cut-out indicates overheating of the magnetron. Check for restricted air flow to the magnetron, especially the cooling fan air guide.</li><li>5. Reconnect all leads removed from components during testing.</li><li>6. Reinstall the outer case (cabinet).</li><li>7. Reconnect the power supply cord after the outer case is installed.</li><li>8. Run the oven and check all functions.</li></ol>

## TEST PROCEDURES

PROCEDURE LETTER	COMPONENT TEST
	<p>CAUTION: IF THE THERMAL CUT-OUT INDICATES AN OPEN CIRCUIT AT ROOM TEMPERATURE, REPLACE THERMAL CUT-OUT.</p>
<b>F</b>	<p><b><u>SECONDARY INTERLOCK SWITCH TEST</u></b></p> <ol style="list-style-type: none"> <li>1. Disconnect the power supply cord, and then remove outer case.</li> <li>2. Open the door and block it open.</li> <li>3. Discharge high voltage capacitor.</li> <li>4. Isolate the switch and connect the ohmmeter to the common (COM.) and normally open (NO) terminal of the switch. The meter should indicate an open circuit with the door open and a closed circuit with the door closed. If improper operation is indicated, replace the secondary interlock switch.</li> <li>5. Reconnect all leads removed from components during testing.</li> <li>6. Reinstall the outer case (cabinet).</li> <li>7. Reconnect the power supply cord after the outer case is installed.</li> <li>8. Run the oven and check all functions.</li> </ol> <p><b><u>PRIMARY INTERLOCK SYSTEM TEST</u></b></p> <p><b><u>DOOR SENSING SWITCH</u></b></p> <ol style="list-style-type: none"> <li>1. Disconnect the power supply cord, and then remove outer case.</li> <li>2. Open the door and block it open.</li> <li>3. Discharge high voltage capacitor.</li> <li>4. Isolate the switch and connect the ohmmeter to the common (COM.) and normally open (NO) terminal of the switch. The meter should indicate an open circuit with the door open and a closed circuit with the door closed. If improper operation is indicated, replace the door sensing switch.</li> <li>5. Reconnect all leads removed from components during testing.</li> <li>6. Reinstall the outer case (cabinet).</li> <li>7. Reconnect the power supply cord after the outer case is installed.</li> <li>8. Run the oven and check all functions.</li> </ol> <p>NOTE: If the door sensing switch contacts fail in the open position and the door is closed, the cooling fan, turntable and oven light will be activated by RY1.</p> <p><b><u>PRIMARY INTERLOCK RELAY (RY2)</u></b></p> <ol style="list-style-type: none"> <li>1. Disconnect the power supply cord, and then remove outer case.</li> <li>2. Open the door and block it open.</li> <li>3. Discharge high voltage capacitor.</li> <li>4. Disconnect two (2) wire leads from the male tab terminals of the Primary Interlock Relay. Check the state of the relay contacts using a ohmmeter. The relay contacts should be open. If the relay contacts are closed, replace the circuit board entirely or the relay itself.</li> <li>5. Reconnect all leads removed from components during testing.</li> <li>6. Reinstall the outer case (cabinet).</li> <li>7. Reconnect the power supply cord after the outer case is installed.</li> <li>8. Run the oven and check all functions.</li> </ol>
<b>G</b>	<p><b><u>MONITOR SWITCH TEST</u></b></p> <ol style="list-style-type: none"> <li>1. Disconnect the power supply cord, and then remove outer case.</li> <li>2. Open the door and block it open.</li> <li>3. Discharge high voltage capacitor.</li> <li>4. Before performing this test, make sure that the secondary interlock switch and the primary interlock relay are operating properly, according to the above Switch Test Procedure. Disconnect the wire lead from the monitor switch (COM) terminal. Check the monitor switch operation by using the ohmmeter as follows. When the door is open, the meter should indicate a closed circuit. When the monitor switch actuator is pushed by a screw driver through the lower latch hole on the front plate of the oven cavity with the door opened (in this condition the plunger of the monitor switch is pushed in), the meter should indicate an open circuit. If improper operation is indicated, the switch may be defective. After testing the monitor switch, reconnect the wire lead to the monitor switch (COM) terminal and check the continuity of the monitor circuit.</li> </ol>



## TEST PROCEDURES

PROCEDURE  
LETTER

## COMPONENT TEST

5. Reconnect all leads removed from components during testing.
6. Reinstall the outer case (cabinet).
7. Reconnect the power supply cord after the outer case is installed.
8. Run the oven and check all functions.

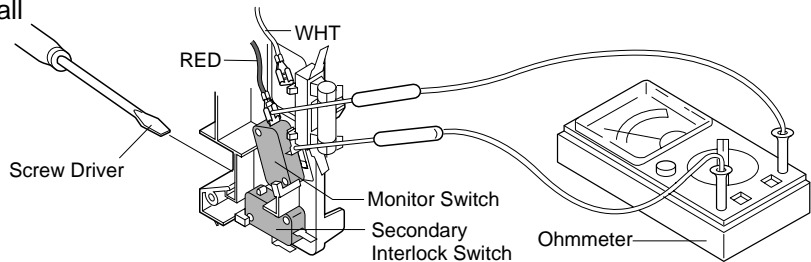
**H BLOWN MONITOR FUSE TEST**

1. Disconnect the power supply cord, and then remove outer case.
2. Open the door and block it open.
3. Discharge high voltage capacitor.
4. If the monitor fuse is blown when the door is opened, check the primary interlock relay, secondary interlock switch and monitor switch according to the "TEST PROCEDURE" for those switches before replacing the blown monitor fuse.

**CAUTION: BEFORE REPLACING A BLOWN MONITOR FUSE, TEST THE PRIMARY INTERLOCK RELAY, SECONDARY INTERLOCK SWITCH, DOOR SENSING SWITCH AND MONITOR SWITCH FOR PROPER OPERATION.**

If the monitor fuse is blown by improper switch operation, the monitor fuse and monitor switch must be replaced with "monitor fuse and monitor switch assembly" part number FFS-BA021WRK0, even if the monitor switch operates normally. The monitor fuse and monitor switch assembly is comprised of a 20 ampere fuse and switch.

5. Reconnect all leads removed from components during testing.
6. Reinstall the outer case (cabinet).
7. Reconnect the power supply cord after the outer case is installed.
8. Run the oven and check all functions.

**I TOUCH CONTROL PANEL ASSEMBLY TEST**

The touch control panel consists of circuits including semiconductors such as LSI, ICs, etc. Therefore, unlike conventional microwave ovens, proper maintenance cannot be performed with only a voltmeter and ohmmeter.

In this service manual, the touch control panel assembly is divided into two units, Control Unit and Key Unit, and also the Control Unit is divided into two units, CPU Unit and Power Unit, and troubleshooting by unit replacement is described according to the symptoms indicated.

**Before testing,**

- 1) Disconnect the power supply cord, and then remove outer case.
  - 2) Open the door and block it open.
  - 3) Discharge high voltage capacitor.
  - 4) Disconnect the leads to the primary of the power transformer.
  - 5) Ensure that these leads remain isolated from other components and oven chassis by using insulation tape.
1. Key Unit.
 

NOTE ;

    - 1) Check Key unit ribbon connection before replacement.
    - 2) Re-install the outer case (cabinet).
    - 3) Reconnect the power supply cord after the outer case is installed.
    - 4) Run the oven and check all functions.

The following symptoms indicate a defective key unit.

    - a) When touching the pads, a certain pad produces no signal at all.
    - b) When touching a number pad, two figures or more are displayed.

## TEST PROCEDURES

PROCEDURE LETTER	COMPONENT TEST
	<p>c) When touching the pads, sometimes a pad produces no signal. If the Key unit is defective.</p> <ol style="list-style-type: none"> <li>1) Disconnect the power supply cord, and then remove outer case.</li> <li>2) Open the door and block it open.</li> <li>3) Discharge high voltage capacitor.</li> <li>4) Replace the Key unit.</li> <li>5) Reconnect all leads removed from components during testing.</li> <li>6) Re-install the outer case (cabinet).</li> <li>7) Reconnect the power supply cord after the outer case is installed.</li> <li>8) Run the oven and check all functions.</li> </ol>
2.	<p><b>Control Unit</b></p> <p>The following symptoms indicate a defective control unit. Before replacing the control unit, perform the Key unit test (Procedure J) to determine if control unit is faulty.</p>
2-1	<p>In connection with pads.</p> <ol style="list-style-type: none"> <li>a) When touching the pads, a certain group of pads do not produce a signal.</li> <li>b) When touching the pads, no pads produce a signal.</li> </ol>
2-2	<p>In connection with indicators</p> <ol style="list-style-type: none"> <li>a) At a certain digit, all or some segments do not light up.</li> <li>b) At a certain digit, brightness is low.</li> <li>c) Only one indicator does not light.</li> <li>d) The corresponding segments of all digits do not light up; or they continue to light up.</li> <li>e) Wrong figure appears.</li> <li>f) A certain group of indicators do not light up.</li> <li>g) The figure of all digits flicker.</li> </ol>
2-3	<p>Other possible problems caused by defective control unit.</p> <ol style="list-style-type: none"> <li>a) Buzzer does not sound or continues to sound.</li> <li>b) Clock does not operate properly.</li> <li>c) Cooking is not possible.</li> </ol>
	<p>When testing is completed,</p> <ol style="list-style-type: none"> <li>1) Disconnect the power supply cord, and then remove outer case.</li> <li>2) Open the door and block it open.</li> <li>3) Discharge high voltage capacitor.</li> <li>4) Reconnect all leads removed from components during testing.</li> <li>5) Re-install the outer case (cabinet).</li> <li>6) Reconnect the power supply cord after the outer case is installed.</li> <li>7) Run the oven and check all functions.</li> </ol>

---

### **J      KEY UNIT TEST**

1. Disconnect the power supply cord, and then remove outer case.
2. Open the door and block it open.
3. Discharge high voltage capacitor.
4. If the display fails to clear when the STOP/CLEAR pad is depressed, first verify the flat ribbon cable is making good contact, verify that the door sensing switch operates properly; that is the contacts are closed when the door is closed and open when the door is open. If the door sensing switch is good, disconnect the flat ribbon cable that connects the key unit to the control unit and make sure the door sensing switch is closed (either close the door or short the door sensing switch connector). Use the Key unit matrix indicated on the control panel schematic and place a jumper wire between the pins that correspond to the STOP/CLEAR pad making momentary contact. If the control unit responds by clearing with a beep the key unit is faulty and must be replaced. If the control unit does not respond, it is faulty and must be replaced. If a specific pad does not respond, the above method may be used (after clearing the control unit) to determine if the control unit or key pad is at fault.
5. Reconnect all leads removed from components during testing.
6. Re-install the outer case (cabinet).
7. Reconnect the power supply cord after the outer case is installed.
8. Run the oven and check all functions.

TEST PROCEDURES

PROCEDURE  
LETTER

COMPONENT TEST

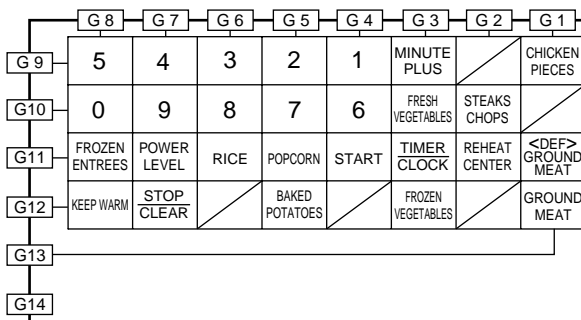

**K RELAY TEST**

1. Disconnect the power supply cord, and then remove outer case.
2. Open the door and block it open.
3. Discharge high voltage capacitor.
4. Disconnect the leads to the primary of the power transformer.
5. Ensure that these leads remain isolated from other components and oven chassis by using insulation tape.
6. After that procedure, re-connect the power supply cord.
7. Remove the outer case and check voltage between Pin No. 1 of the 2 pin connector (A) and the normal open terminal of the relay RY1 on the control unit with an A.C. voltmeter.  
The meter should indicate 120 volts, if not check oven circuit.

**RY1 and RY2 Relay Test**

These relays are operated by D.C. voltage

Check voltage at the relay coil with a D.C. voltmeter during the microwave cooking operation.

DC. voltage indicated ..... Defective relay.

DC. voltage not indicated ..... Check diode which is connected to the relay coil. If diode is good, control unit is defective.

RELAY SYMBOL	OPERATIONAL VOLTAGE	CONNECTED COMPONENTS
RY1	Approx. -12.2V D.C.	Oven lamp / Turntable motor / Cooling fan motor
RY2	Approx. -11.1V D.C.	Power transformer

8. Disconnect the power supply cord, and then remove outer case.
9. Open the door and block it open.
10. Discharge high voltage capacitor.
11. Reconnect all leads removed from components during testing.
12. Re-install the outer case (cabinet).
13. Reconnect the power supply cord after the outer case is installed.
14. Run the oven and check all functions.

**L COMPU DEFROST TEST**

**WARNING :** The oven should be fully assembled before following procedure.

- (1) Place one cup of water in the center of the turntable tray in the oven cavity.
- (2) Close the door, touch the " STEAKS CHOPS " once.
- (3) The oven is in Compu Defrost cooking condition.
- (4) The oven will operate as follows.

MENU	1ST STAGE		2ND STAGE	
	LEVEL	TIME	LEVEL	TIME
0.5lb Steaks/Chops	70%	1min.7sec.	40%	30sec.

- (5) If improper operation is indicated, the control unit is probably defective and should be checked.

## TEST PROCEDURES

PROCEDURE LETTER	COMPONENT TEST
M	<b>FOIL PATTERN ON THE PRINTED WIRING BOARD TEST</b>

To protect the electronic circuits, this model is provided with a fine foil pattern added to the primary on the PWB, this foil pattern acts as a fuse.

1. Foil pattern check and repairs.

- 1) Disconnect the power supply cord, and then remove outer case.
- 2) Open the door and block it open.
- 3) Discharge high voltage capacitor.
- 4) Follow the troubleshooting guide given below for repair.

STEPS	OCCURRENCE	CAUSE OR CORRECTION
1	Only pattern at "a" is broken.	*Insert jumper wire J1 and solder.
2	Pattern at "a" and "b" are broken.	*Insert the coil RCILF2003YAZZ between "c" and "d".

- 5) Make a visual inspection of the varistor. Check for burned damage and examine the transformer with a tester for the presence of layer short-circuit (check the primary coil resistance which is approximately  $540\Omega \pm 20\%$ ). If any abnormal condition is detected, replace the defective parts.

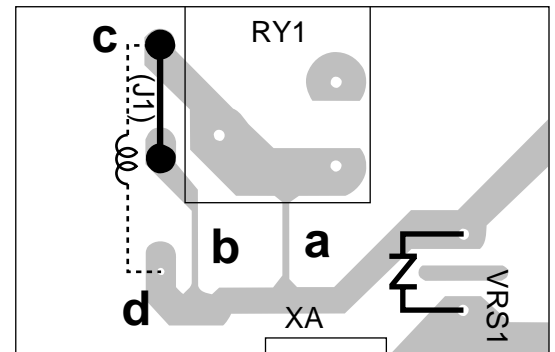

- 6) Reconnect all leads removed from components during testing.
  - 7) Re-install the outer case (cabinet).
  - 8) Reconnect the power supply cord after the outer case is installed.
  - 9) Run the oven and check all functions.
2. Follow the troubleshooting guide given below, if indicator does not light up after above check and repairs are finished.
- 1) Disconnect the power supply cord, and then remove outer case.
  - 2) Open the door and block it open.
  - 3) Discharge high voltage capacitor.
  - 4) Disconnect the leads to the primary of the power transformer.
  - 5) Ensure that these leads remain isolated from other components and oven chassis by using insulation tape.
  - 6) After that procedure, re-connect the power supply cord.
  - 7) Follow the troubleshooting guide given below for repair.

STEPS	OCCURRENCE	CAUSE OR CORRECTION
1	The rated AC voltage is not present between Pin No. 1 of the 2-pin connector (A) and the normal open terminal of the relay RY1.	Check supply voltage and oven power cord.
2	The rated AC voltage is present at primary side of low voltage transformer.	Low voltage transformer or secondary circuit defective. Check and repair.

- 8) Disconnect the power supply cord, and then remove outer case.
- 9) Open the door and block it open.
- 10) Discharge high voltage capacitor.
- 11) Reconnect all leads removed from components during testing.
- 12) Re-install the outer case (cabinet).
- 13) Reconnect the power supply cord after the outer case is installed.
- 14) Run the oven and check all functions.

# TOUCH CONTROL PANEL ASSEMBLY

## OUTLINE OF TOUCH CONTROL PANEL

The touch control section consists of the following units.

- (1) Key Unit
- (2) Control Unit (The Control Unit consists of Power Unit and CPU Unit).

The principal functions of these units and the signals communicated among them are explained below.

### Key Unit

The key unit is composed of a matrix, signals generated in the LSI are sent to the key unit through P20, P21, P22, P23, P24, P25, P26 and P27.

When a key pad is touched, a signal is completed through the key unit and passed back to the LSI through P41, P43, P44, P45 and AN0 to perform the function that was requested.

### Control Unit

Control unit consists of LSI, reset circuit, indicator circuit, power source circuit, relay circuit, buzzer circuit, synchronizing signal circuit and back light circuit.

#### 1) Reset Circuit

This circuit generates a signal which resets the LSI to the initial state when power is supplied.

#### 2) Indicator Circuit

This circuit consists of 22 segments and 3 common electrodes using a Liquid Crystal Display.

#### 3) Power Source Circuit

This circuit generates voltages necessary in the control unit from the AC line voltage.

In addition, the synchronizing signal is available in order to compose a basic standard time in the clock circuit.

Symbol	Voltage	Application
VC	-5V	LSI(IC1)

#### 4) Relay Circuit

A circuit to drive the magnetron, fan motor, turntable motor and light the oven lamp.

#### 5) Buzzer Circuit

The buzzer is responsive to signals from the LSI to emit audible sounds (key touch sound and completion sound).

#### 6) Synchronizing Signal Circuit

The power source synchronizing signal is available in order to compose a basic standard time in the clock circuit.

It accompanies a very small error because it works on commercial frequency.

#### 7) Door Sensing Switch

A switch to "tell" the LSI if the door is open or closed.

#### 8) Back Light Circuit

A circuit to drive the back light (Light emitting diodes LD1- LD4).

## DESCRIPTION OF LSI

### LSI

The I/O signal of the LSI is detailed in the following table.

Pin No.	Signal	I/O	Description
1-2	VL2-VL1	IN	<b>Power source voltage input terminal.</b> Standard voltage for LCD.
3-6	AN7-AN4	IN	<b>Terminal to change cooking input according to the Model.</b> By using the A/D converter contained in the LSI, DC voltage in accordance with the Model in operation is applied to set up its cooking constant.
7	P63	OUT	Terminal not used.
8	AN2	IN	<b>Input terminal to judge the model.</b> Connected to GND through the pull-down resistor R78.
9	AN1	IN	<b>To input signal which communicates the door open/close information to LSI.</b> Door close "H" level signal (0V). Door open "L" level signal (-5V).
10	AN0	IN	<b>Input terminal to judge the model.</b> The signal out of P20 will be input into AN0 through G1 line on key matrix. The LSI will judge the model by this signal.

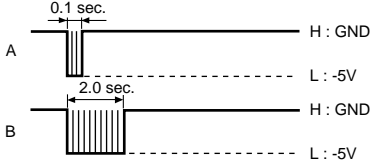
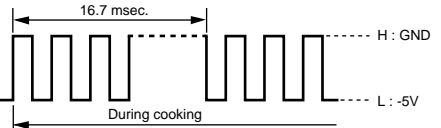
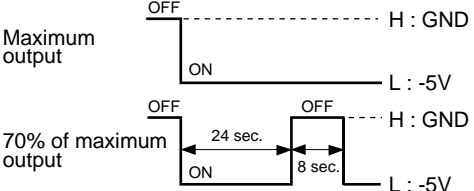
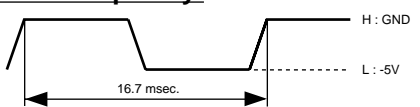
Pin No.	Signal	I/O	Description
11	P57	OUT	Back light circuit (Light emitting diodes) driving signal.
12-13	P56-P55	OUT	Terminal not used.
14	CNTR0	OUT	<p><b>Signal to sound buzzer (2.0 kHz).</b></p> <p>A: key touch sound. B: Completion sound.</p> 
15	P53	OUT	<p><b>Oven lamp, fan motor and turntable motor driving signal</b></p> <p>To turn on and off shut off relay (RY1). The square waveform voltage is delivered to the RY1 driving circuit and RY2 control circuit.</p> 
16	P52	OUT	<p><b>Magnetron high-voltage circuit driving signal.</b></p> <p>To turn on and off the cook relay (RY2). The signals holds "L" level during microwave cooking and "H" level while not cooking. In other cooking modes (variable cooking) the signal turns to "H" level and "L" level in repetition according to the power level.</p> 
17-18	P51-P50	OUT	Terminal not used.
19-20	P47-P46	OUT	Terminal not used.
21	P45	IN	<p><b>Signal coming from touch key.</b></p> <p>When either G12 line on key matrix is touched, a corresponding signal out of P20 - P27 will be input into P45. When no key is touched, the signal is held at "H" level.</p>
22	P44	IN	<p><b>Signal similar to P45.</b></p> <p>When either G11 line on key matrix is touched, a corresponding signal will be input into P44.</p>
23	P43	IN	<p><b>Signal similar to P45.</b></p> <p>When either G10 line on key matrix is touched, a corresponding signal will be input into P43.</p>
24	INT0	IN	<p><b>Signal synchronized with commercial power source frequency.</b></p> <p>This is the basic timing for time processing of LSI.</p> 
25	P41	IN	<p><b>Signal similar to P45.</b></p> <p>When either G9 line on key matrix is touched, a corresponding signal will be input into P41.</p>
26	P40	IN	Connected to GND through the pull-down resistor R90.
27	RESET	IN	<p><b>Auto clear terminal.</b></p> <p>Signal is input to reset the LSI to the initial state when power is applied.</p>
28-29	P71-P70	OUT	Terminal not used.
30	XIN	IN	<p><b>Internal clock oscillation frequency input setting.</b></p> <p>The internal clock frequency is set by inserting the ceramic filter oscillation circuit with respect to XOUT terminal.</p>
31	XOUT	OUT	<p><b>Internal clock oscillation frequency control output.</b></p> <p>Output to control oscillation input of XIN.</p>
32	VSS	IN	<p><b>Power source voltage: -5.0V.</b></p> <p>VC voltage of power source circuit input.</p>
33	P27	OUT	<p><b>Key strobe signal.</b></p> <p>Signal applied to touch-key section. A pulse signal is input to P41, P43, P44 and P45 terminal while one of G8 line keys on key matrix is touched.</p>

Pin No.	Signal	I/O	Description																																																
34	P26	OUT	<b>Key strobe signal.</b> Signal applied to touch-key section. A pulse signal is input to P41, P43, P44 and P45 terminal while one of G7 line keys on key matrix is touched.																																																
35	P25	OUT	<b>Key strobe signal.</b> Signal applied to touch-key section. A pulse signal is input to P41, P43, P44 and P45 terminal while one of G6 line keys on key matrix is touched.																																																
36	P24	OUT	<b>Key strobe signal.</b> Signal applied to touch-key section. A pulse signal is input to P41, P43, P44 and P45 terminal while one of G5 line keys on key matrix is touched.																																																
37	P23	OUT	<b>Key strobe signal.</b> Signal applied to touch-key section. A pulse signal is input to P41, P43, P44 and P45 terminal while one of G4 line keys on key matrix is touched.																																																
38	P22	OUT	<b>Key strobe signal.</b> Signal applied to touch-key section. A pulse signal is input to P41, P43, P44 and P45 terminal while one of G3 line keys on key matrix is touched.																																																
39	P21	OUT	<b>Key strobe signal.</b> Signal applied to touch-key section. A pulse signal is input to P41, P43, P44 and P45 terminal while one of G2 line keys on key matrix is touched.																																																
40	P20	OUT	<b>Key strobe signal.</b> Signal applied to touch-key section. A pulse signal is input to AN0, P41, P43, P44 and P45 terminal while one of G1 line keys on key matrix is touched.																																																
41-48	P17-P10	OUT	Terminal not used.																																																
49-50	P07-P06	OUT	Terminal not used.																																																
51-72	SEG21-SEG0	OUT	<b>Segment data signal.</b> Connected to LCD.  The relation between signals are as follows: <table border="0" style="width: 100%; border-collapse: collapse;"> <thead> <tr> <th style="text-align: left;">LSI signal (Pin No.)</th> <th style="text-align: left;">LCD (segment)</th> <th style="text-align: left;">LSI signal (Pin No.)</th> <th style="text-align: left;">LCD (segment)</th> </tr> </thead> <tbody> <tr> <td>SEG 21 (51)</td> <td>..... SEG3</td> <td>SEG 10 (62)</td> <td>..... SEG14</td> </tr> <tr> <td>SEG 20 (52)</td> <td>..... SEG2</td> <td>SEG 9 (63)</td> <td>..... SEG13</td> </tr> <tr> <td>SEG 19 (53)</td> <td>..... SEG1</td> <td>SEG 8 (64)</td> <td>..... SEG12</td> </tr> <tr> <td>SEG 18 (54)</td> <td>..... SEG22</td> <td>SEG 7 (65)</td> <td>..... SEG11</td> </tr> <tr> <td>SEG 17 (55)</td> <td>..... SEG21</td> <td>SEG 6 (66)</td> <td>..... SEG10</td> </tr> <tr> <td>SEG 16 (56)</td> <td>..... SEG20</td> <td>SEG 5 (67)</td> <td>..... SEG9</td> </tr> <tr> <td>SEG 15 (57)</td> <td>..... SEG19</td> <td>SEG 4 (68)</td> <td>..... SEG8</td> </tr> <tr> <td>SEG 14 (58)</td> <td>..... SEG18</td> <td>SEG 3 (69)</td> <td>..... SEG7</td> </tr> <tr> <td>SEG 13 (59)</td> <td>..... SEG17</td> <td>SEG 2 (70)</td> <td>..... SEG6</td> </tr> <tr> <td>SEG 12 (60)</td> <td>..... SEG16</td> <td>SEG 1 (71)</td> <td>..... SEG5</td> </tr> <tr> <td>SEG 11 (61)</td> <td>..... SEG15</td> <td>SEG 0 (72)</td> <td>..... SEG4</td> </tr> </tbody> </table>	LSI signal (Pin No.)	LCD (segment)	LSI signal (Pin No.)	LCD (segment)	SEG 21 (51)	..... SEG3	SEG 10 (62)	..... SEG14	SEG 20 (52)	..... SEG2	SEG 9 (63)	..... SEG13	SEG 19 (53)	..... SEG1	SEG 8 (64)	..... SEG12	SEG 18 (54)	..... SEG22	SEG 7 (65)	..... SEG11	SEG 17 (55)	..... SEG21	SEG 6 (66)	..... SEG10	SEG 16 (56)	..... SEG20	SEG 5 (67)	..... SEG9	SEG 15 (57)	..... SEG19	SEG 4 (68)	..... SEG8	SEG 14 (58)	..... SEG18	SEG 3 (69)	..... SEG7	SEG 13 (59)	..... SEG17	SEG 2 (70)	..... SEG6	SEG 12 (60)	..... SEG16	SEG 1 (71)	..... SEG5	SEG 11 (61)	..... SEG15	SEG 0 (72)	..... SEG4
LSI signal (Pin No.)	LCD (segment)	LSI signal (Pin No.)	LCD (segment)																																																
SEG 21 (51)	..... SEG3	SEG 10 (62)	..... SEG14																																																
SEG 20 (52)	..... SEG2	SEG 9 (63)	..... SEG13																																																
SEG 19 (53)	..... SEG1	SEG 8 (64)	..... SEG12																																																
SEG 18 (54)	..... SEG22	SEG 7 (65)	..... SEG11																																																
SEG 17 (55)	..... SEG21	SEG 6 (66)	..... SEG10																																																
SEG 16 (56)	..... SEG20	SEG 5 (67)	..... SEG9																																																
SEG 15 (57)	..... SEG19	SEG 4 (68)	..... SEG8																																																
SEG 14 (58)	..... SEG18	SEG 3 (69)	..... SEG7																																																
SEG 13 (59)	..... SEG17	SEG 2 (70)	..... SEG6																																																
SEG 12 (60)	..... SEG16	SEG 1 (71)	..... SEG5																																																
SEG 11 (61)	..... SEG15	SEG 0 (72)	..... SEG4																																																
73/74	VCC/VREF	IN	Connected to GND.																																																
75	AVSS	IN	Connected to VC.																																																
76	COM3	OUT	Terminal not used.																																																
77	COM2	OUT	<b>Common data signal.</b> Connected to LCD signal COM1.																																																
78	COM1	OUT	<b>Common data signal.</b> Connected to LCD signal COM2.																																																
79	COM0	OUT	<b>Common data signal.</b> Connected to LCD signal COM3.																																																
80	VL3	IN	<b>Power source voltage input terminal.</b> Standard voltage for LCD.																																																



## TOUCH CONTROL PANEL SERVICING

### 1. Precautions for Handling Electronic Components

This unit uses CMOS LSI in the integral part of the circuits. When handling these parts, the following precautions should be strictly followed. CMOS LSI have extremely high impedance at its input and output terminals. For this reason, it is easily influenced by the surrounding high voltage power source, static electricity charge in clothes, etc. and sometimes it is not fully protected by the built-in protection circuit. In order to protect CMOS LSI.

- 1) When storing and transporting, thoroughly wrap them in aluminium foil. Also wrap all PW boards containing them in aluminium foil.
- 2) When soldering, ground the technician as shown in the figure and use grounded soldering iron and work table.

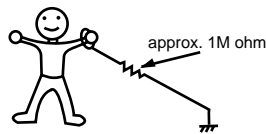

### 2. Servicing of Touch Control Panel

We describe the procedures to permit servicing of the touch control panel of the microwave oven and the precautions you must take when doing so. To perform the servicing, power to the touch control panel is available either from the power line of the oven itself or from an external power source.

#### (1) Servicing the touch control panel with power supply of the oven:

##### CAUTION:

**THE HIGH VOLTAGE TRANSFORMER OF THE MICROWAVE OVEN IS STILL LIVE DURING SERVICING AND PRESENTS A HAZARD.**

Therefore, before checking the performance of the touch control panel,

- 1) Disconnect the power supply cord, and then remove outer case.
- 2) Open the door and block it open.
- 3) Discharge high voltage capacitor.
- 4) Disconnect the leads to the primary of the power transformer.
- 5) Ensure that these leads remain isolated from other components and oven chassis by using insulation tape.
- 6) After that procedure, re-connect the power supply cord.

After checking the performance of the touch control panel,

- 1) Disconnect the power supply cord.
- 2) Open the door and block it open.
- 3) Re-connect the leads to the primary of the power transformer.
- 4) Re-install the outer case (cabinet).
- 5) Re-connect the power supply cord after the outer case is installed.
- 6) Run the oven and check all functions.

A. On some models, the power supply cord between the touch control panel and the oven itself is so short that the two can't be separated. For those models, check and repair all the controls (sensor-related ones included) of the touch control panel while keeping it connected to the oven.

B. On some models, the power supply cord between the touch control panel and the oven proper is long enough that they may be separated from each other. For those models, it is possible to check and repair the controls of the touch control panel while keeping it apart from the oven proper; in this case you must short both ends of the door sensing switch (on PWB) of the touch control panel with a jumper, which activates an operational state that is equivalent to the oven door being closed. As for the sensor-related controls of the touch control panel, checking them is possible if dummy resistor(s) with resistance equal to that of the controls are used.

#### (2) Servicing the touch control panel with power supply from an external power source:

Disconnect the touch control panel completely from the oven proper, and short both ends of the door sensing switch (on PWB) of the touch control panel, which activates an operational state that is equivalent to the oven door being closed. Connect an external power source to the power input terminal of the touch control panel, then it is possible to check and repair the controls of the touch control panel it is also possible to check the sensor-related controls of the touch control panel by using the dummy resistor(s).

### 3. Servicing Tools

Tools required to service the touch control panel assembly.

- 1) Soldering iron: 30W  
(It is recommended to use a soldering iron with a grounding terminal.)
- 2) Oscilloscope: Single beam, frequency range: DC-10MHz type or more advanced model.
- 3) Others: Hand tools

### 4. Other Precautions

- 1) Before turning on the power source of the control unit, remove the aluminium foil applied for preventing static electricity.
- 2) Connect the connectors of the key unit to the control unit being sure that the lead wires are not twisted.
- 3) After aluminium foil is removed, be careful that abnormal voltage due to static electricity etc. is not applied to the input or output terminals.
- 4) Attach connectors, electrolytic capacitors, etc. to PWB, making sure that all connections are tight.
- 5) Be sure to use specified components where high precision is required.

## COMPONENT REPLACEMENT AND ADJUSTMENT PROCEDURE

### WARNING AGAINST HIGH VOLTAGE:

Microwave ovens contain circuitry capable of producing very high voltage and current, contact with following parts may result in severe, possibly fatal, electric shock.

(Example)

High Voltage Capacitor, Power Transformer, Magnetron, High Voltage Rectifier Assembly, High Voltage Harness etc..

**WARNING:** Avoid possible exposure to microwave energy. Please follow the instructions below before operating the oven.

1. Disconnect the power supply cord.
2. Visually check the door and cavity face plate for damage (dents, cracks, signs of arcing etc.).

Carry out any remedial work that is necessary before operating the oven.

Do not operate the oven if any of the following conditions exist;

1. Door does not close firmly.
2. Door hinge, support or latch hook is damaged.
3. The door gasket or seal is damaged.

4. The door is bent or warped.
5. There are defective parts in the door interlock system.
6. There are defective parts in the microwave generating and transmission assembly.
7. There is visible damage to the oven.

Do not operate the oven:

1. Without the RF gasket (Magnetron).
2. If the wave guide or oven cavity are not intact.
3. If the door is not closed.
4. If the outer case (cabinet) is not fitted.

### WARNING FOR WIRING

To prevent an electric shock, take the following precautions.

1. Before wiring,
  - 1) Disconnect the power supply cord.
  - 2) Open the door block it open.
  - 3) Discharge the high voltage capacitor and wait for 60 seconds.
2. Don't let the wire leads touch to the following parts;
  - 1) High voltage parts:  
Magnetron, High voltage transformer, High voltage capacitor and High voltage rectifier assembly.
  - 2) Hot parts:  
Oven lamp, Magnetron, High voltage transformer

and Oven cavity.

- 3) Sharp edge:  
Bottom plate, Oven cavity, Waveguide flange, Chassis support and other metallic plate.
- 4) Movable parts (to prevent a fault)  
Fan blade, Fan motor, Switch.
3. Do not catch the wire leads in the outer case cabinet.
4. Insert the positive lock connector until its pin is locked and make sure that the wire leads do not come off even if the wire leads are pulled.
5. To prevent an error function, connect the wire leads correctly, referring to the Pictorial Diagram.

Please refer to 'OVEN PARTS, CABINET PARTS, CONTROL PANEL PARTS, DOOR PARTS', when carrying out any of the following removal procedures:

### OUTER CASE REMOVAL

To remove the outer case, proceed as follows.

1. Disconnect the power supply cord.
2. Open the oven door and block it open.
3. Remove the two (2) screws from the lower portion of the rear cabinet using a T20H Torx type or GTXH20-100 screw driver.
4. Remove the remaining two (2) screws from rear and one (1) screw along the right side of outer case.
5. Slide the entire outer case back out about 1 inch (3 cm) to free it from retaining clips on the cavity face plate.
6. Lift entire outer case from the unit.

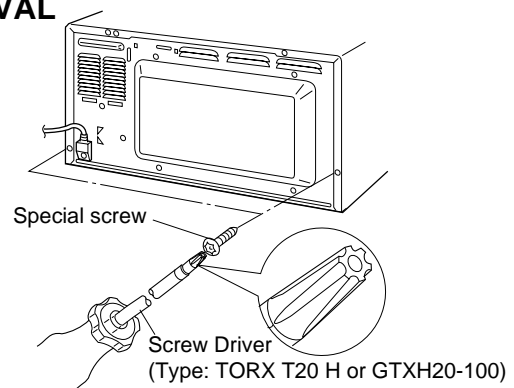

Figure C-1. Special screws position

- CAUTION:** 1. DISCONNECT OVEN FROM POWER SUPPLY BEFORE REMOVING OUTER CASE.  
2. DISCHARGE THE HIGH VOLTAGE CAPACITOR BEFORE TOUCHING ANY OVEN COMPONENTS OR WIRING.

**NOTE:** When replacing the outer case, the 2 special Torx screws must be reinstalled in the same locations.

## POWER TRANSFORMER REMOVAL

1. Disconnect the power supply cord and then remove outer case.
2. Open the oven door and block it open.
3. Discharge high voltage capacitor.
4. Disconnect wire leads (primary) from power transformer and the filament leads and high voltage wire from the magnetron and capacitor terminals.
5. Remove four (4) screws holding transformer to bottom plate.
6. Remove transformer from bottom plate.

### Reinstallation

1. Rest transformer on the bottom plate with its primary terminals toward the oven face plate.
2. Secure transformer with four screws to bottom plate.
3. Reconnect wire leads (primary) to power transformer and filament leads and high voltage wire of transformer to magnetron and high voltage capacitor. Refer to "PICTORIAL DIAGRAM" on page 28.
4. Reinstall outer case and check that oven is operating properly.

## TERMINAL INSULATOR REPLACEMENT

1. Disconnect the power supply cord, and then remove outer case.
2. Open the door and block it open.
3. Discharge high voltage capacitor.
4. Open covers of the terminal insulator by using small flat type screw driver.
5. Remove the receptacle from the terminal insulator.
6. Now, the terminal insulator is free.

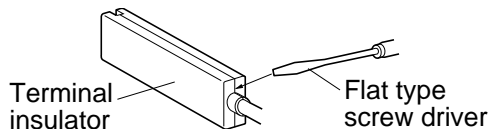

### Installation

1. Insert the receptacle into terminal insulator.
2. Close covers of the terminal insulator, as shown below.
3. Reconnect all leads removed from components during testing.
4. Reinstall the outer case (cabinet).
5. Reconnect the power supply cord after the outer case is installed.
6. Run the oven and check all functions.

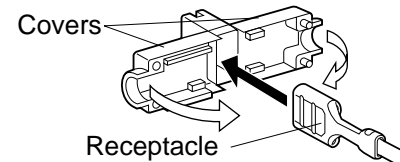

## HIGH VOLTAGE RECTIFIER AND HIGH VOLTAGE CAPACITOR REMOVAL

1. Disconnect the power supply cord and then remove outer case.
2. Open the door and block it open.
3. Discharge high voltage capacitor.
4. Disconnect the high voltage wire of the power transformer from the high voltage capacitor.
5. Disconnect the high voltage wire of high voltage rectifier assembly from the magnetron.
6. Disconnect the filament lead (short one) of the power transformer from the high voltage capacitor.
7. Remove two (2) screws holding capacitor holder to oven cavity rear plate.

8. Remove one (1) screw holding high voltage rectifier assembly to capacitor holder.
9. Disconnect rectifier terminal from capacitor. High voltage rectifier assembly is now free.
10. Remove capacitor holder. Capacitor is now free.

**CAUTION:** WHEN REPLACING HIGH VOLTAGE RECTIFIER AND HIGH VOLTAGE CAPACITOR, GROUND SIDE TERMINAL OF THE HIGH VOLTAGE RECTIFIER MUST BE SECURED FIRMLY WITH A GROUNDING SCREW.

## MAGNETRON REMOVAL

### Removal

1. Disconnect the power supply cord and then remove outer case.
2. Open the door and block it open.
3. Discharge high voltage capacitor.
4. Disconnect all wire leads from magnetron.
5. Remove the five (5) screws holding chassis support to magnetron, oven cavity back plate, oven cavity front

- flange and fan duct.
6. Remove the chassis support from oven.
7. Carefully remove the four (4) screws holding magnetron to waveguide flange.
8. Lift up magnetron with care so that magnetron antenna is not hit by any metal object around antenna.
9. Now, the magnetron is free.

### Reinstallation

1. Reinstall the magnetron to waveguide flange with the four (4) screws.
2. Insert the two (2) tabs of the chassis support to the oven cavity front plate and the back plate.
3. Hold the chassis support to the oven cavity back plate, oven cavity front flange, magnetron and the fan duct with the five (5) screws.

4. Reconnect the wire leads to the magnetron and thermal cut-out (MG). Refer to "PICTORIAL DIAGRAM" on page 28.
5. Reinstall outer case and check that the oven is operating properly.

**CAUTION: WHEN REPLACING MAGNETRON, BE SURE THE R.F. GASKET IS IN PLACE AND MOUNTING SCREWS ARE TIGHTENED SECURELY.**

### POSITIVE LOCK® CONNECTOR (NO-CASE TYPE) REMOVAL

1. Disconnect the power supply cord, and then remove outer case.
2. Open the door and block it open.
3. Discharge high voltage capacitor.
4. Push the lever of positive lock® connector.
5. Pull down on the positive lock® connector.

**CAUTION: WHEN CONNECTING THE POSITIVE LOCK® CONNECTORS TO THE TERMINALS, CONNECT THE POSITIVE LOCK® SO THAT THE LEVER FACES YOU**

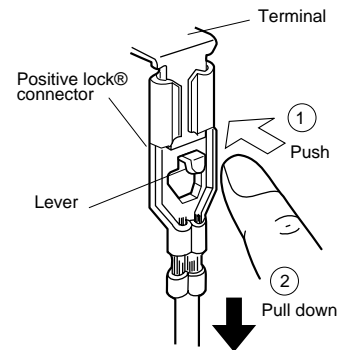

**Figure C-2. Positive lock® connector**

### CONTROL PANEL ASSEMBLY REMOVAL

1. Disconnect the power supply cord and then remove outer case.
2. Open the door and block it open.
3. Discharge high voltage capacitor.
4. Disconnect wire leads from the door sensing switch and the oven cavity front flange.
5. Disconnect the wire leads from panel components.
6. Remove the one (1) screw holding the control panel assembly to the oven flange.
7. Slide the control panel assembly upward and remove it.
8. Now, individual components can be removed.

**NOTE:** 1. Before attaching a new key unit, wipe off remaining adhesive on the control panel frame surfaces completely with a soft cloth soaked in alcohol.

2. When attaching the key unit to the control panel frame, adjust the upper edge and right edge of the key unit to the correct position of control panel frame.

3. Stick the key unit firmly to the control panel frame by rubbing with soft cloth not to scratch.

#### CPU UNIT

**NOTE:** Handle the CPU unit carefully so that the ribbon cable does not come off. Because the ribbon cable is glued on the LCD and the printed wiring board only by heated paste.

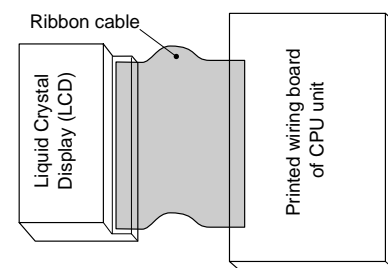

**CPU unit**

### TURNTABLE MOTOR REMOVAL

1. Disconnect the power supply cord.
2. Remove turntable and turntable support from oven cavity.
3. Lay the oven on it's backside. Remove the turntable motor cover by snipping off the material in four corners.
4. Where the corners have been snipped off bend corner areas flat. No sharp edges must be evident after removal of the turntable motor cover.

5. Disconnect wire leads from turntable motor. (See "Positive lock connector removal")
6. Remove two (2) screws holding turntable motor to oven cavity.
7. Now the turntable motor is free.
8. After replacement use the one (1) screw to fit the turntable motor cover.

### COOLING FAN MOTOR REMOVAL

#### REMOVAL

1. Disconnect the power supply cord and then remove outer case.

2. Open the door and block it open.
3. Discharge high voltage capacitor.
4. Disconnect the wire leads from the fan motor.

5. Remove the magnetron and chassis support from the waveguide flange, referring to "MAGNETRON REMOVAL".
6. Release the snap of the main wire harness from the fan duct.
7. Remove one (1) screw holding the fan duct assembly to oven cavity.
8. Release the main wire harness from the hole of the fan duct.
9. Release the fan duct from the waveguide flange.
10. Release the fan duct assembly from the oven cavity.
11. Remove the fan blade from the fan motor shaft according to the following procedure.
12. Hold the edge of the rotor of the fan motor by using a pair of groove joint pliers.

**CAUTION:**

- \* **Make sure that no metal pieces enter the gap between the rotor and the stator of the fan motor because the rotor is easily shaven by pliers and metal pieces may be produced.**
  - \* **Do not touch the pliers to the coil of the fan motor because the coil may be cut or injured.**
  - \* **Do not disfigure the bracket by touching with the pliers.**
13. Remove the fan blade from the shaft of the fan motor by pulling and rotating the fan blade with your hand.
  14. Now, the fan blade will be free.

**CAUTION:**

- \* **Do not reuse the removed fan blade because the hole (for shaft) may be larger than normal.**
15. Remove the two (2) screws holding the fan motor to the fan duct.
  16. Now, the fan motor is free.

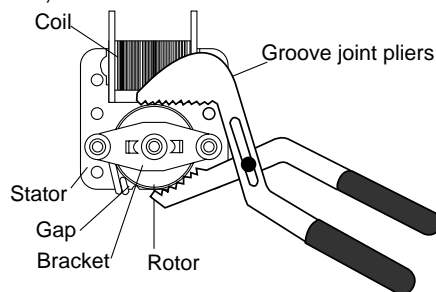
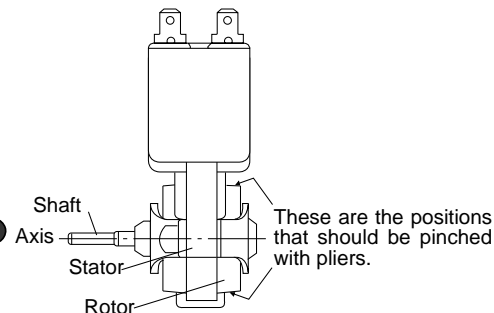
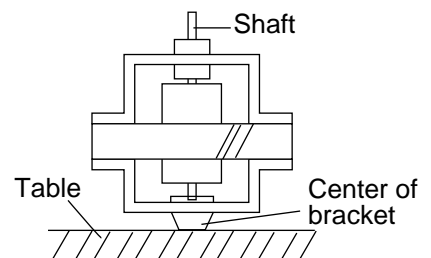
**Rear View****Side View****INSTALLATION**

1. Install the fan motor to the fan duct with the two (2) screws.
2. Install the fan blade to the fan motor shaft according to the following procedure.
3. Hold the center of the bracket which supports the shaft of the fan motor on the flat table.
4. Apply the screw lock tight into the hole (for shaft) of the fan blade.
5. Install the fan blade to the shaft of fan motor by pushing the fan blade with a small, light weight, ball peen hammer or rubber mallet.

**CAUTION:**

- \* **Do not hit the fan blade strongly when installed because the bracket may be disfigured.**
  - \* **Make sure that the fan blade rotates smooth after installation.**
  - \* **Make sure that the axis of the shaft is not slanted.**
6. Catch three holes of fan duct on three tabs of the waveguide flange.
  7. Install the fan duct assembly to the oven cavity with the one (1) screw.
  8. Insert the snap of the main wire harness to the hole of the fan duct and insert the main wire harness into the hole of the fan duct.
  9. Install the magnetron and the chassis support to the oven cavity, referring to "Reinstall of MAGNETRON REMOVAL".
  10. Connect the wire leads to the fan motor, referring to the pictorial diagram.

**DOOR SENSING SWITCH/SECONDARY INTERLOCK SWITCH AND MONITOR SWITCH REMOVAL**

1. Disconnect the power supply cord and remove outer case.
2. Open the door and block it open.
3. Discharge high voltage capacitor.
4. Disconnect wire leads from the switches.
5. Remove two (2) screws holding latch hook to oven flange.
6. Remove latch hook assembly from oven flange.
7. Push outward on the two (2) retaining tabs holding switch in place.
8. Switch is now free.

**Reinstallation**

1. Reinstall each switch in its place. The secondary interlock/monitor switches are in the lower position and the door sensing switch is in the upper position.
2. Reconnect wire leads to each switch. Refer to pictorial diagram.
3. Secure latch hook (with two (2) mounting screws) to oven flange.
4. Make sure that the monitor switch is operating properly and check continuity of the monitor circuit. Refer to chapter "Test Procedure" and Adjustment procedure.

**DOOR SENSING SWITCH/SECONDARY INTERLOCK SWITCH AND MONITOR SWITCH ADJUSTMENT**

1. Disconnect the power supply cord, and then remove outer case.
2. Open the door and block it open.
3. Discharge high voltage capacitor.



If the door sensing switch, secondary interlock switch and monitor switch do not operate properly due to a misadjustment, the following adjustment should be made.

- Loosen the two (2) screws holding latch hook to the oven cavity front flange.
- With door closed, adjust latch hook by moving it back and forth, and up and down. In and out play of the door allowed by the upper and lower position of the latch hook should be less than 0.5mm. The vertical position of the latch hook should be adjusted so that the door sensing switch and secondary interlock switch are activated with the door closed. The horizontal position of the latch hook should be adjusted so that the plunger of the monitor switch is pressed with the door closed.
- Secure the screws with washers firmly.
- Check the operation of all switches. If each switch has not activated with the door closed, loosen screw and adjust the latch hook position.

#### After adjustment, check the following.

- In and out play of door remains less than 0.5mm when in the latched position. First check upper position of latch hook, pushing and pulling upper portion of door toward the oven face. Then check lower portion of the latch

hook, pushing and pulling lower portion of the door toward the oven face. Both results (play in the door) should be less than 0.5mm.

- The contacts of door sensing switch and secondary interlock switch open within 1.5mm gap between right side of cavity face plate and door when door is open.
- Monitor switch contacts close when door is opened.
- Reinstall outer case and check for microwave leakage around door with an approved microwave survey meter. (Refer to Microwave Measurement Procedure.)

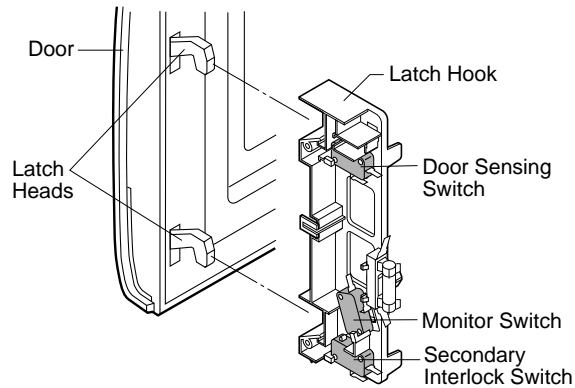

Figure C-3. Latch Switch Adjustments

## DOOR REPLACEMENT

### REMOVAL

- Disconnect the power supply cord.
- Open the door slightly.
- Insert a putty knife (thickness of about 0.5mm) into the gap between the choke cover and door frame as shown in Figure C-4 to free engaging parts.
- Pry the choke cover by inserting a putty knife as shown Figure C-4.
- Release choke cover from door panel.
- Now choke cover is free.

**NOTE: When carrying out any repair to the door, do not bend or warp the slit choke (tabs on the door panel assembly) to prevent microwave leakage.**

- Release two (2) pins of door panel from two (2) holes of upper and lower oven hinges by lifting up.
- Now, door panel with door frame is free from oven cavity.

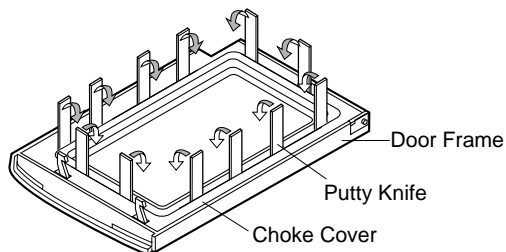

Figure C-4. Door Disassembly

- Remove the four (4) screws holding the door panel to the door frame.
- Release door panel from eight (8) tabs of door frame.
- Now, door panel with sealer film is free.
- Tear sealer film from door panel.
- Now, door panel is free.
- Slide latch head upward and remove it from door frame

with releasing latch spring from door frame and latch head.

- Now, latch head and latch spring are free.
- Remove door screen from door frame.
- Now, door screen is free.

### REINSTALLATION

- Reinstall door screen to door frame .
- Reinstall the latch spring to the latch head. Reinstall the latch spring to the door frame. Reinstall latch head to door frame.
- Reinstall door panel to door frame by fitting eight (8) tabs of door frame to eight (8) holes of door panel.
- Hold the door panel to the door frame with the four (4) screws.
- Put sealer film on door panel. Refer to "Sealer Film" about how to handle new one.
- Catch two (2) pins of door panel on two (2) hole of upper and lower oven hinges.
- Reinstall choke cover to door panel by pushing.

**Note: After any service to the door;**

- Make sure that door sensing switch and secondary interlock switch are operating properly. (Refer to chapter "Test Procedures".)**
- An approved microwave survey meter should be used to assure compliance with proper microwave radiation emission limitation standards.**

**After any service, make sure of the following :**

- Door latch heads smoothly catch latch hook through latch holes and that latch head goes through center of latch hole.
- Deviation of door alignment from horizontal line of cavity face plate is to be less than 1.0mm.

3. Door is positioned with its face pressed toward cavity face plate.
4. Check for microwave leakage around door with an approved microwave survey meter. (Refer to Microwave Measurement Procedure.)

Note: The door on a microwave oven is designed to act as an electronic seal preventing the leakage of microwave energy from oven cavity during cook cycle. This function does not require that door be airtight, moisture (condensation)-tight or light-tight. Therefore, occasional appearance of moisture, light or sensing of gentle warm air movement around oven door is not abnormal and do not of themselves indicate a leakage of microwave energy from oven cavity.

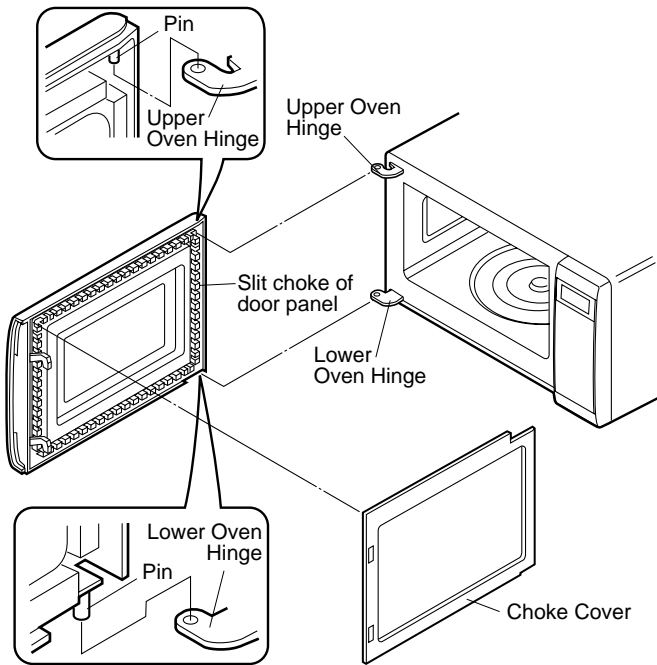
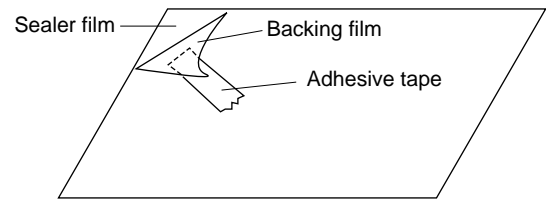

**Figure C-5. Door Replacement**

## SEALER FILM

### Installation

1. Put the adhesive tape on the backing film of the sealer film as shown in Fig. C-6.
2. Tear the backing film by pulling the adhesive tape.
3. Put the pasted side of the sealer film on the door panel



**Figure C-6. Sealer film**



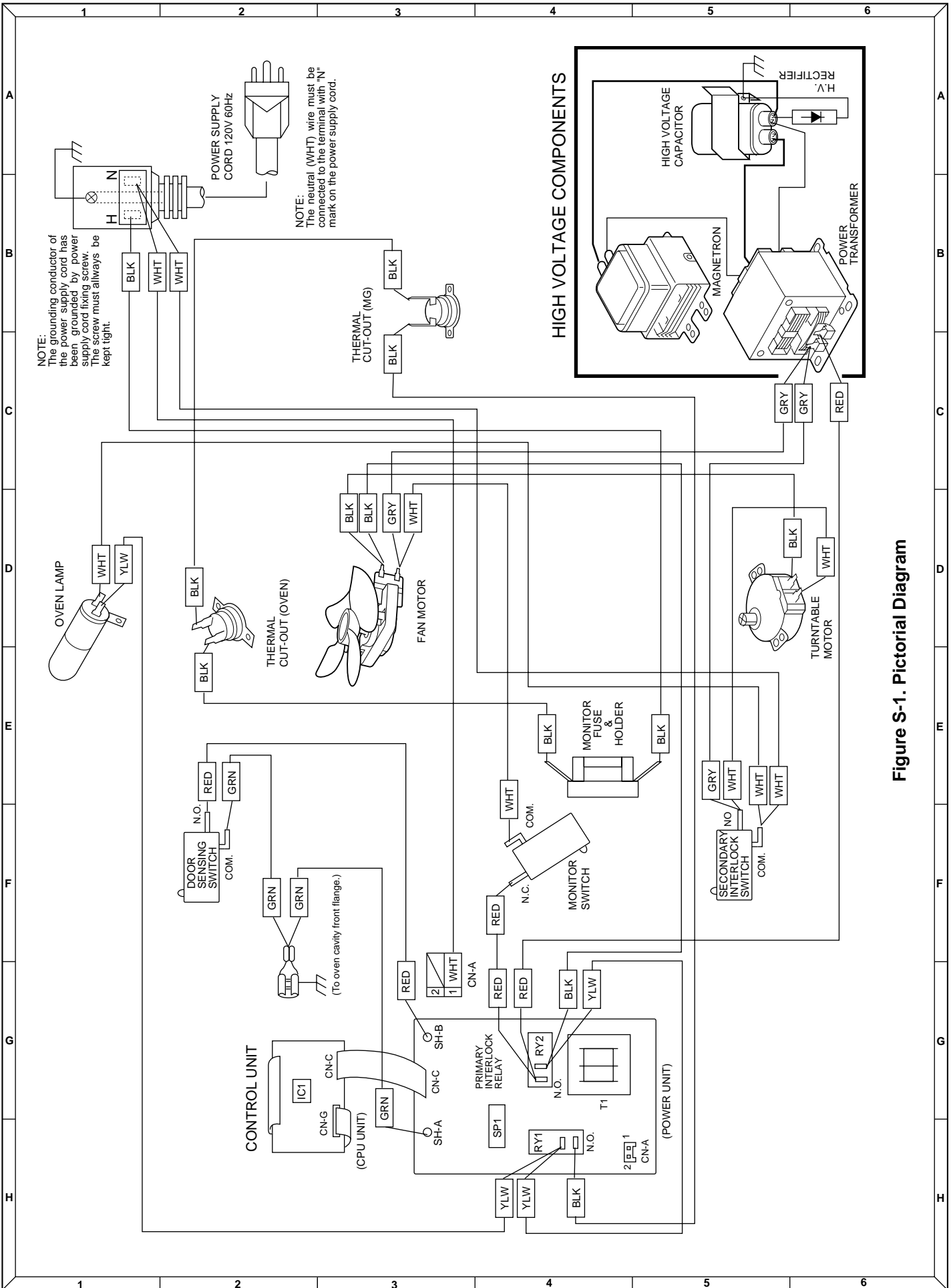

Figure S-1. Pictorial Diagram

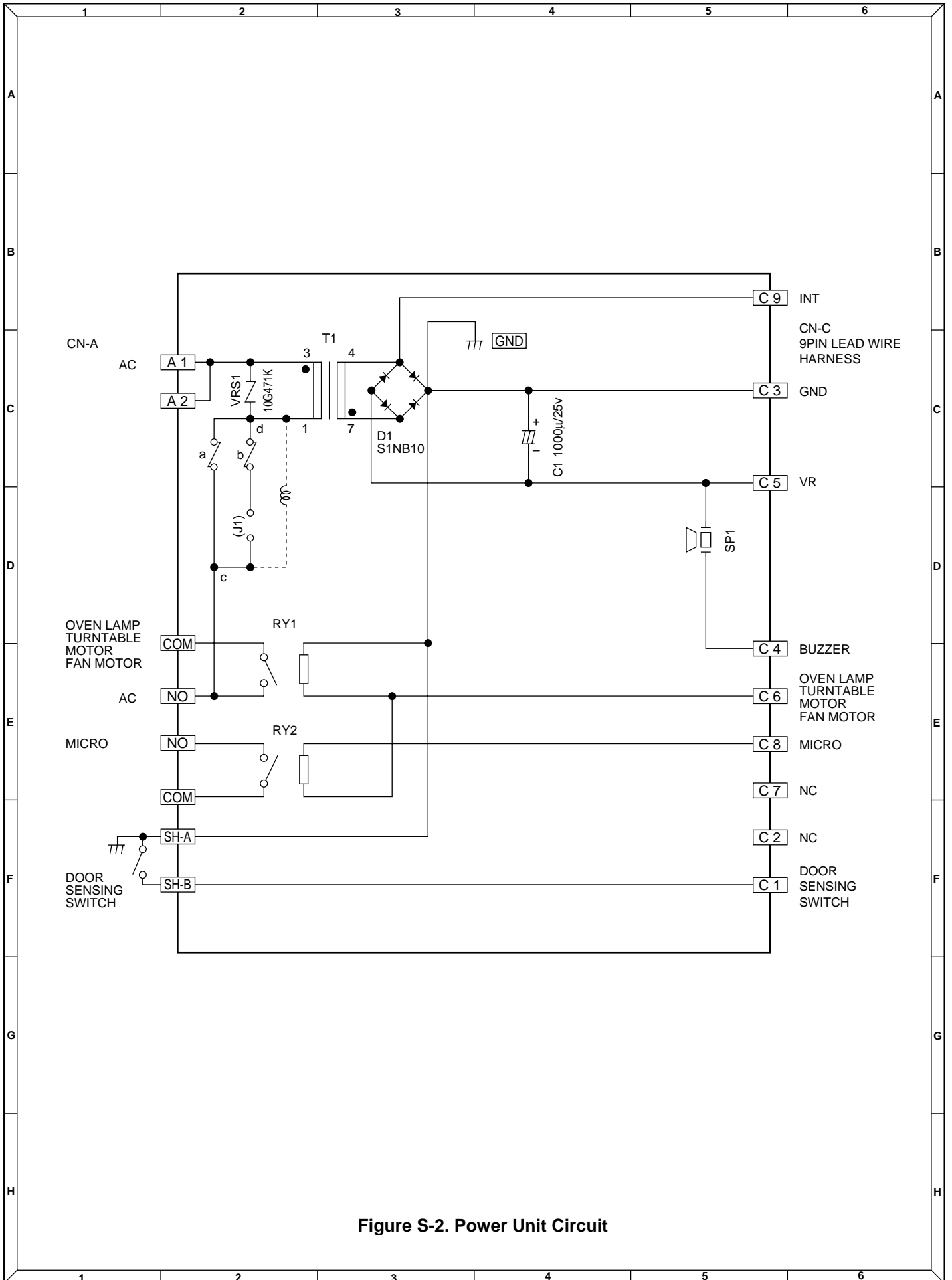

Figure S-2. Power Unit Circuit



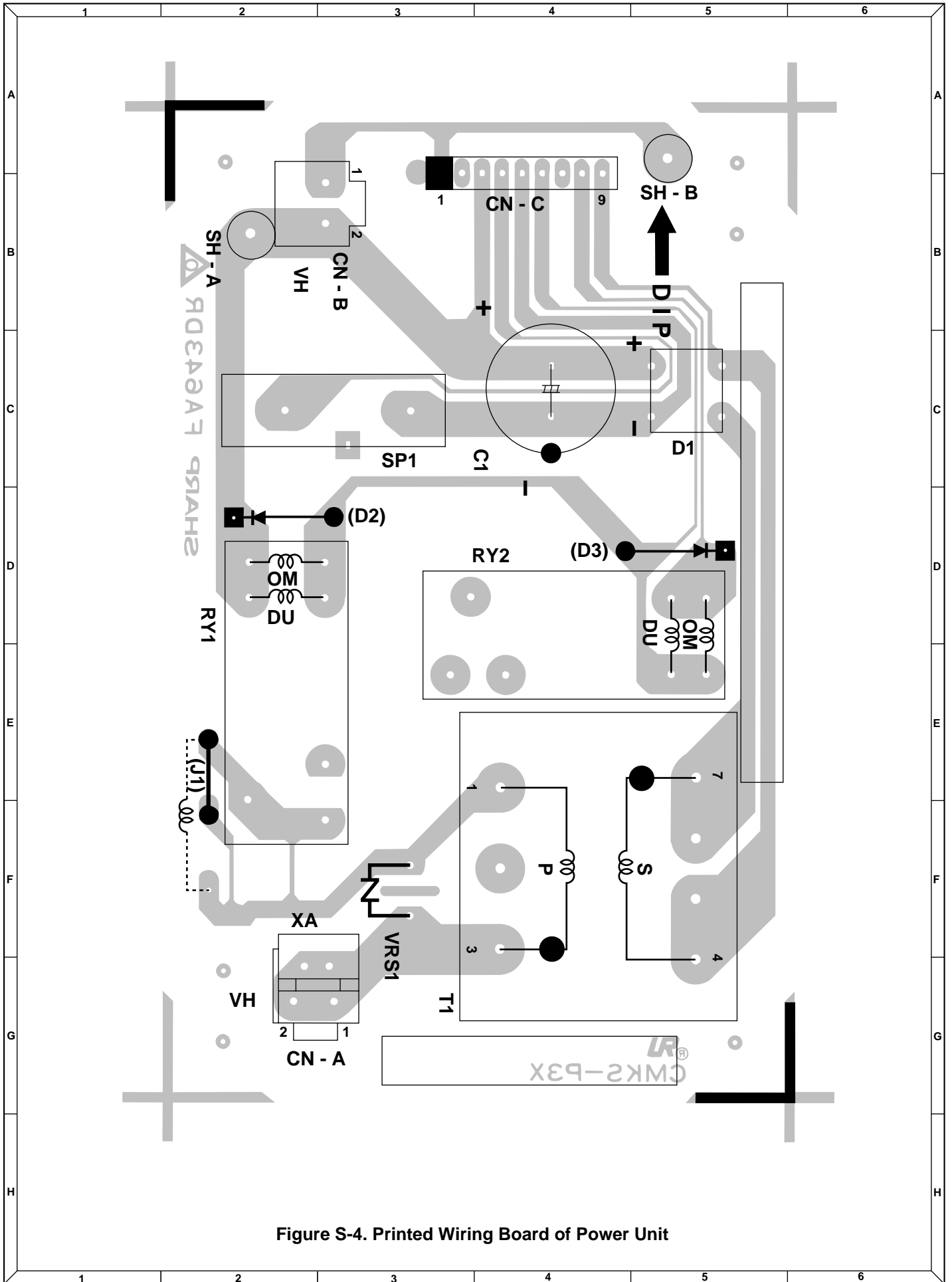

Figure S-4. Printed Wiring Board of Power Unit

## PARTS LIST

**Note: The parts marked "Δ" may cause undue microwave exposure.  
The parts marked "\*" are used in voltage more than 250V.**

REF. NO.	PART NO.	DESCRIPTION	Q'TY	CODE
<b>ELECTRIC PARTS</b>				
1- 1	QSW-MA147WRZZ	2nd interlock switch/door sensing switch	2	AG
1- 1	QSW-MA137WRE0	2nd interlock switch/door sensing switch (Interchangeable)	2	AH
1- 2	QFSHDA009WRE0	Fuse holder	1	AH
1- 3	FFS-BA021WRK0	Monitor fuse 20A and monitor switch (V-16G-2C25) assembly	1	AL
1- 3	FFS-BA023WRK0	" " (AM51620C53Y1) assembly (Interchangeable)	1	AS
1- 4	RTHM-A127WRZZ	Thermal cut-out 125 deg.	1	AK
1- 5	FACCDAA085WREZ	Power supply cord	1	AQ
1- 5	FACCDAA083WRE0	Power supply cord (Interchangeable)	1	AQ
* 1- 6	FH-DZA088WRK0	High voltage rectifier assembly	1	AP
* 1- 6	FH-DZA094WRKZ	High voltage rectifier assembly (Interchangeable)	1	AU
* 1- 7	RC-QZA288WRZZ	High voltage capacitor	1	AW
* 1- 7	RC-QZA235WRE0	High voltage capacitor (Interchangeable)	1	AU
Δ* 1- 8	RV-MZA295WRE0	Magnetron	1	BF
Δ* 1- 8	RV-MZA291WRE0	Magnetron (Interchangeable)	1	BH
1- 9	RMOTEA383WRE0	Fan motor	1	AV
1- 9	RMOTEA355WRE0	Fan motor (Interchangeable)	1	AU
* 1-10	RTRN-A662WRZZ	Power transformer	1	BQ
1-11	RLMPTA082WRZZ	Oven lamp	1	AL
1-12	RMOTDA186WRE0	Turntable motor	1	AW
1-12	RMOTDA161WRE0	Turntable motor (Interchangeable)	1	AS
1-12	RMOTDA211WRE0	Turntable motor (Interchangeable)	1	AS
1-12	RMOTDA229WRE0	Turntable motor (Interchangeable)	1	AQ
1-13	RTHM-A120WRE0	Thermal cut-out 145 deg.C	1	AH
1-13	RTHM-A080WRE0	Thermal cut-out 145 deg.C(Interchangeable)	1	AP

### CABINET PARTS

2- 1	GCABUA836WRPZ	Outer case cabinet [R-310FK]	1	BD
2- 1	GCABUA834WRPZ	Outer case cabinet [R-310FW]	1	BD
2- 2	GDAI-A343WRWZ	Bottom plate	1	AX
2- 3	GLEGPA074WRE0	Foot	1	AC

### CONTROL PANEL PARTS

3- 1	DPWBFC021WRKZ	Power unit	1	BA
3- 1A	QCNCMA446DRE0	2-pin connector (CN-A)	1	AC
3- 1B	FW-VZA250DRE0	9pin wire harness (CN-C)	1	AW
3- 1C	FW-VZA195DRE0	Switch harness A (SH-A)	1	AD
3- 1D	FW-VZA256DREZ	Switch harness B (SH-B)	1	AF
C1	VCEAB31EW108M	Capacitor 1000 uF 25V	1	AE
D1	RSRCDA013DRE0	Diode bridge (S1NB10)	1	AG
RY1	RRLY-A094DRE0	Relay (OMIF-S-112LM)	1	AN
RY2	RRLY-A114DRE0	Relay (DU12D1-1P(M)-R)	1	AN
SP1	RALM-A014DRE0	Buzzer (PKM22EPT)	1	AG
T1	RTRNPA110DRE0	Transformer	1	AP
VRS1	RH-VZA032DRE0	Varistor (10G471K)	1	AE
3- 2	DPWBFC163WRKZ	CPU unit	1	BN
3- 3	FPNLCB613WRKZ	Control panel frame with key unit [R-310FW]	1	BB
3- 3	FPNLCB614WRKZ	Control panel frame with key unit [R-310FK]	1	BB
3- 3-1	FUNTKB105WREZ	Key unit [R-310FW]	1	AX
3- 3-1	FUNTKB106WREZ	Key unit [R-310FK]	1	AX
3- 4	PSHEPA588WRE0	LED sheet	1	AE
3- 5	LHLD-A205WRF0	LCD holder	1	AF
3- 6	XEPSD30P08XS0	Screw; 3mm x 8mm	4	AA

### OVEN PARTS

Δ 4- 1	PCUSUA235WRF0	Cushion	1	AE
4- 2	PPACGA084WRF0	TTM packing	1	AF
4- 3	PHOK-A116WRFZ	Latch hook	1	AH
4- 4	LBNDKA099WRW0	Capacitor holder	1	AD
4- 5	NFANJA029WRE0	Fan blade	1	AL
4- 6	PDUC-A790WRWZ	Fan duct	1	AZ
Δ 4- 7	*****	Oven cavity (Not a replaceable part)	1	--
4- 8	LANGFA194WRW0	Chassis support	1	AU
4- 9	PCUSGA560WREZ	Cushion	1	AB
4-10	LANG-A079WRWZ	Air guide	1	AF
4-11	LANG-A078WRWZ	Barrier	1	AF
4-12	NCPL-A053WRFZ	Coupling	1	AE
4-13	PCUSUA511WRF0	Cushion	1	AC

REF. NO.	PART NO.	DESCRIPTION	Q'TY	CODE
4-14	PCOVPA349WRE0	Waveguide cover	1	AE
4-15	PCUSGA339WRP0	Cushion	1	AG
4-16	PCUSGA399WRE0	Cushion	1	AF
4-17	PCUSUA512WRP0	Cushion	1	AB
4-18	PCUSGA321WRP0	Cushion	1	AH
4-19	PCUSUA186WRP0	Cushion	1	AC
4-20	PCUSUA157WRP0	Cushion	1	AC
4-21	PCUSUA212WRP0	Cushion	2	AB
4-22	PCUSUA474WRP0	Cushion	2	AC

### DOOR PARTS

△	5- 1	FDORFA332WRT0	Door panel	1	BD
	5- 2	PSHEPA382WRE0	Sealer film	1	AH
△	5- 3	GWAKPA789WRRZ	Door frame [R-310FK]	1	AZ
△	5- 3	GWAKPA832WRRZ	Door frame [R-310FW]	1	AX
	5- 4	HPNL-A740WRRZ	Door screen [R-310FK]	1	AS
	5- 4	HPNL-A742WRRZ	Door screen [R-310FW]	1	AS
△	5- 5	LSTPPA193WRFZ	Latch head	1	AE
	5- 6	MSPRTA187WRE0	Latch spring	1	AC
	5- 7	XEPSD40P08000	Screw : 4mm x 8mm	6	AA
	5- 8	PCUSUA461WRP0	Cushion	1	AB
	5- 9	PCUSUA553WRPZ	Cushion	2	AC
	5-10	PCUSUA554WRPZ	Cushion	2	AB
	5-11	GCOVHA417WRFZ	Choke cover	1	AG

### MISCELLANEOUS

	6- 1	FROLPA079WRK0	Turntable support	1	AQ
	6- 2	NTNT-A084WRE0	Turntable tray	1	AQ
	6- 3	FW-VZB902WREZ	Main wire harness	1	AV
	6- 4	TINSEA927WRRZ	Instruction book	1	AK
	6- 5	PZET-A012WRE0	Terminal insulator	1	AB
	6- 6	TCAUAA265WRRZ	DHHS caution label	1	AC
	6- 7	TCAUAA254WRR0	Monitor caution label	1	AC

### SCREWS,NUTS AND WASHERS

	7- 1	XHPSD40P08K00	Screw : 4mm x 8mm	6	AA
	7- 2	XHPSD30P06000	Screw : 3mm x 6mm	1	AA
	7- 3	XHTSD40P08RV0	Screw : 4mm x 8mm	4	AA
	7- 4	XHTSD40P12RV0	Screw : 4mm x 12mm	1	AA
	7- 5	XOTSD40P12RV0	Screw : 4mm x 12mm	1	AA
	7- 6	XOTSD40P08000	Screw : 4mm x 8mm	19	AA
	7- 7	XOTSF40P08000	Screw : 4mm x 8mm [R-310FK]	1	AA
	7- 7	XOTSE40P08000	Screw : 4mm x 8mm [R-310FW]	1	AA
	7- 8	LX-CZA070WRE0	Special screw (Torx tamper proof screw)	2	AC
	7- 9	LX-CZ0052WRE0	Special screw	2	AA
	7-10	XHPSD40P08000	Screw : 4mm x 8mm	4	AA

### HOW TO ORDER REPLACEMENT PARTS

To have your order filled promptly and correctly, please furnish the following information.

1. MODEL NUMBER
2. REF. NO.
3. PART NO.
4. DESCRIPTION

Order Parts from the authorized SHARP parts Distributor for your area.

Defective parts requiring return should be returned as indicated in the Service Policy.

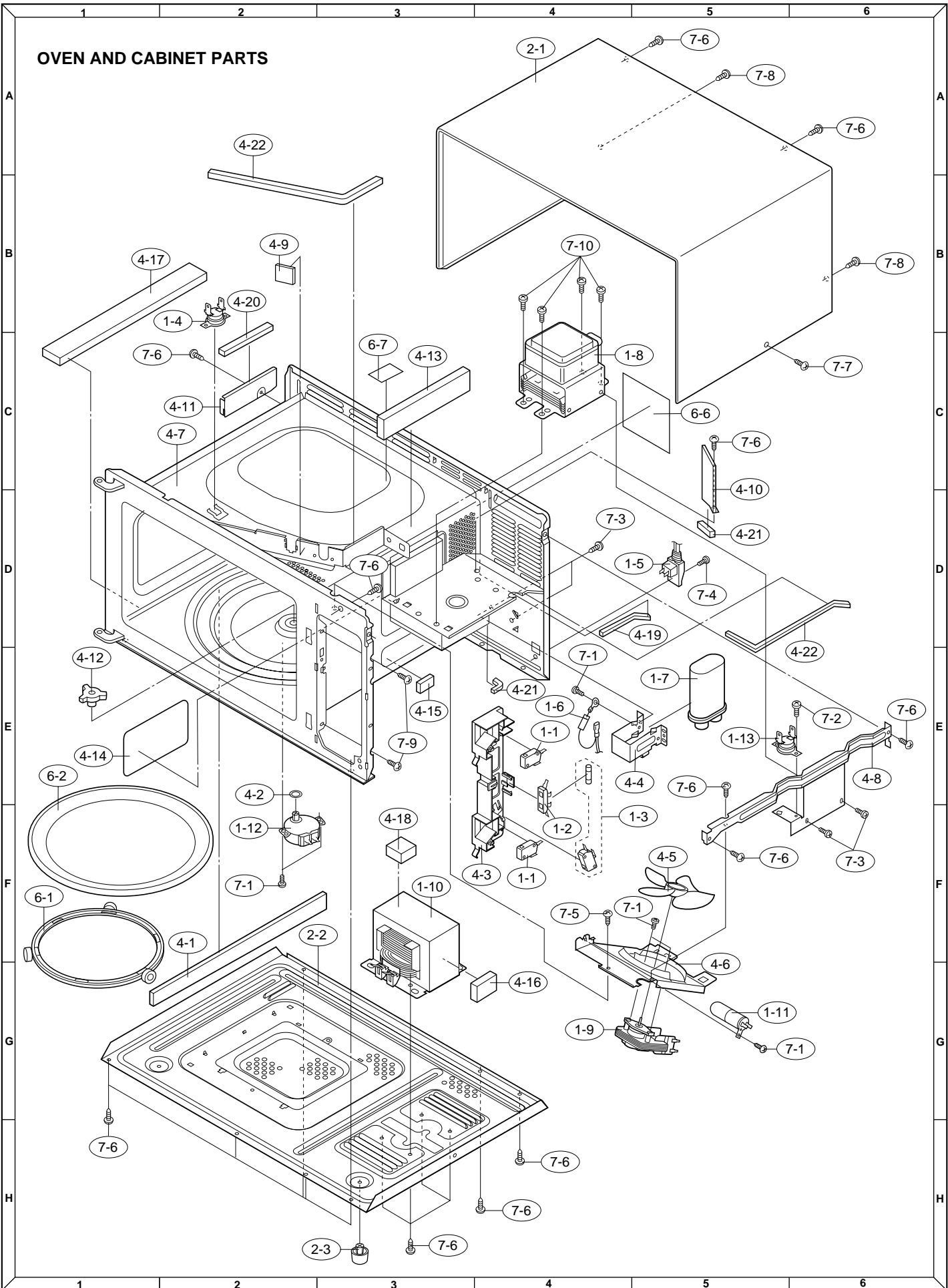



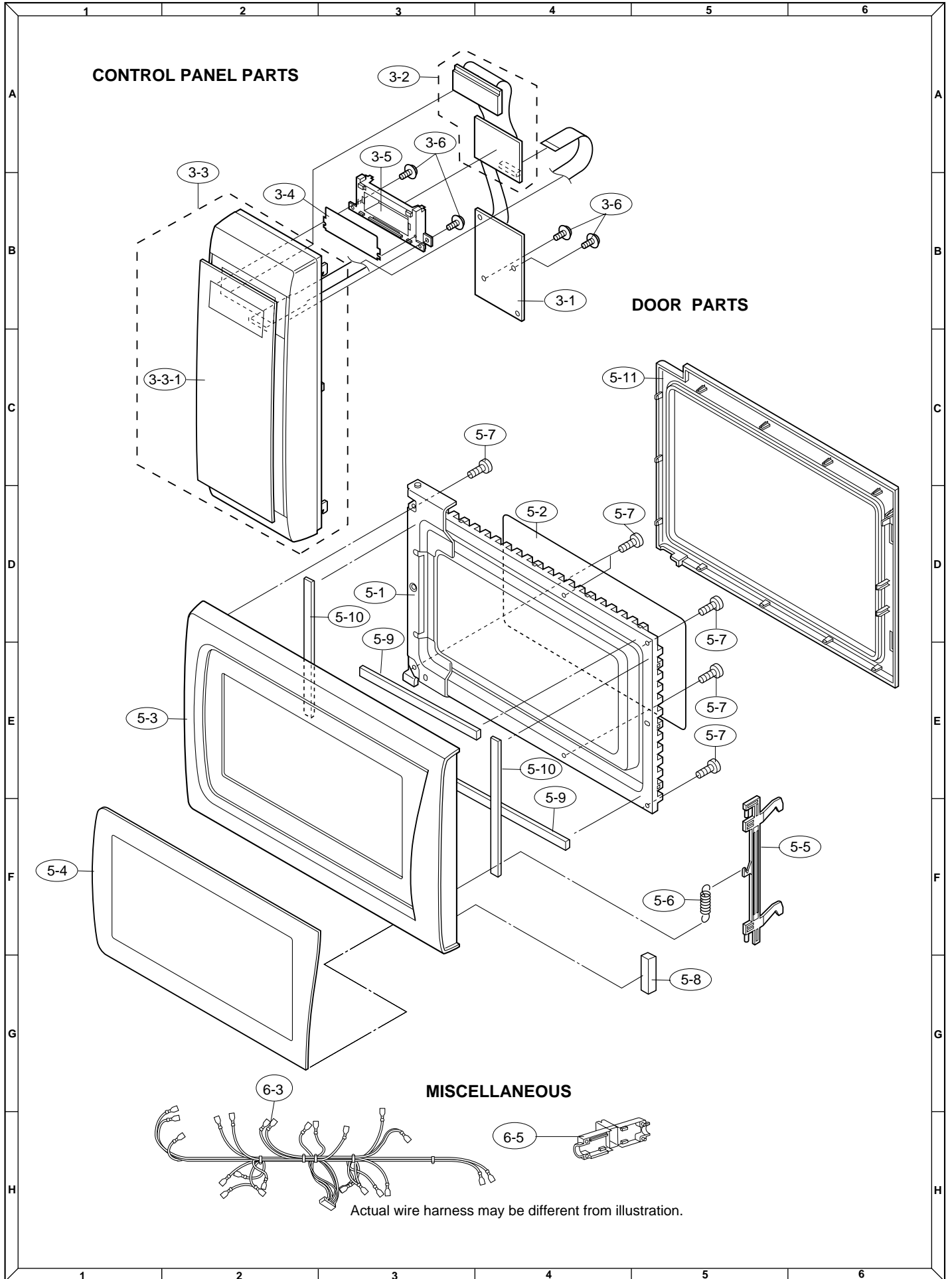

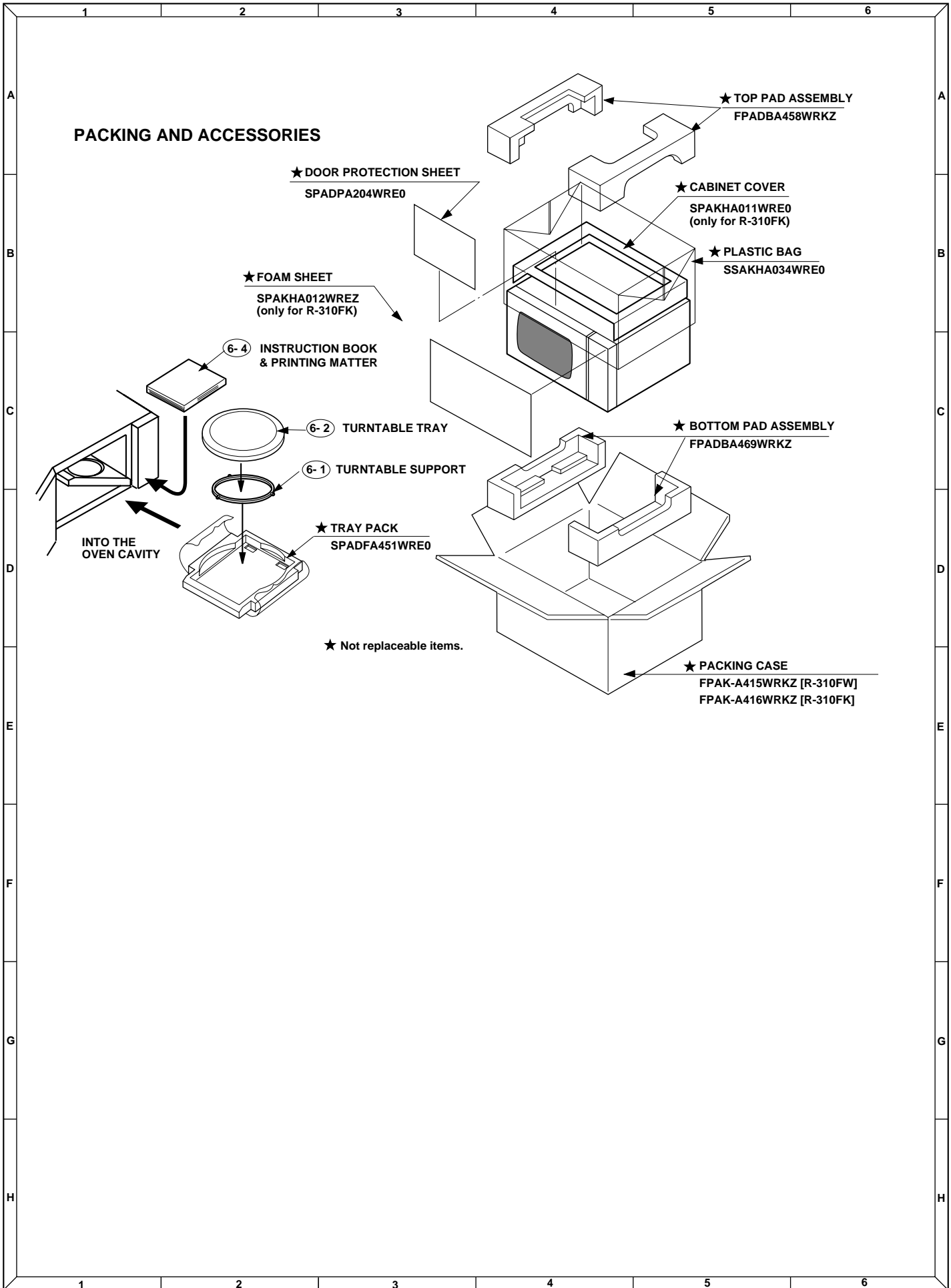



# SHARP

COPYRIGHT © 2002 BY SHARP CORPORATION

ALL RIGHTS RESERVED.

No part of this publication may be reproduced, stored in retrieval systems, or transmitted in any form or by any means, electronic, mechanical, photocopying, recording, or otherwise, without prior written permission of the publisher.