

This Owner's Manual is provided and hosted by [Appliance Factory Parts](#).



# Sharp R320BK Owner's Manual

[Shop genuine replacement parts for Sharp R320BK](#)



[Find Your Sharp Microwave Parts - Select From 1193 Models](#)

----- Manual continues below -----

# SHARP SERVICE MANUAL

S2805R320BPW/

## MICROWAVE OVEN

### MODELS

**R-320BB**  
**R-320BK**  
**R-320BW**

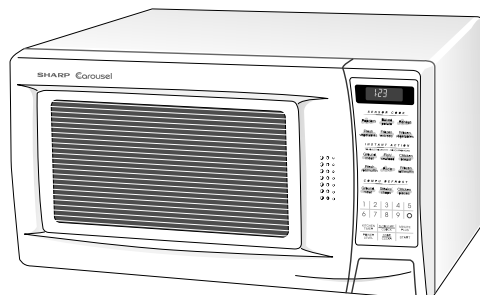

In the interest of user-safety the oven should be restored to its original condition and only parts identical to those specified should be used.

**WARNING TO SERVICE PERSONNEL:** Microwave ovens contain circuitry capable of producing very high voltage and current, contact with following parts may result in a severe, possibly fatal, electrical shock. (High Voltage Capacitor, High Voltage Power Transformer, Magnetron, High Voltage Rectifier Assembly, High Voltage Harness etc..)

### TABLE OF CONTENTS

	Page
PRECAUTIONS TO BE OBSERVED BEFORE AND DURING SERVICING TO AVOID POSSIBLE EXPOSURE TO EXCESSIVE MICROWAVE ENERGY	INSIDE FRONT COVER
BEFORE SERVICING	INSIDE FRONT COVER
WARNING TO SERVICE PERSONNEL	1
MICROWAVE MEASUREMENT PROCEDURE	2
FOREWORD AND WARNING	3
PRODUCT SPECIFICATIONS	4
GENERAL INFORMATION	4
OPERATION	6
TROUBLESHOOTING GUIDE	9
TEST PROCEDURE	10
TOUCH CONTROL PANEL	20
COMPONENT REPLACEMENT AND ADJUSTMENT PROCEDURE	26
PICTORIAL DIAGRAM	33
POWER UNIT CIRCUIT	34
CPU UNIT CIRCUIT	35
PRINTED WIRING BOARD	36
PARTS LIST	37
PACKING AND ACCESSORIES	41

**SHARP CORPORATION**

This document has been published to be used for after sales service only.  
The contents are subject to change without notice.

## **PRECAUTIONS TO BE OBSERVED BEFORE AND DURING SERVICING TO AVOID POSSIBLE EXPOSURE TO EXCESSIVE MICROWAVE ENERGY**

- (a) Do not operate or allow the oven to be operated with the door open.
- (b) Make the following safety checks on all ovens to be serviced before activating the magnetron or other microwave source, and make repairs as necessary: (1) interlock operation, (2) proper door closing, (3) seal and sealing surfaces (arcing, wear, and other damage), (4) damage to or loosening of hinges and latches, (5) evidence of dropping or abuse.
- (c) Before turning on microwave power for any service test or inspection within the microwave generating compartments, check the magnetron, wave guide or transmission line, and cavity for proper alignment, integrity, and connections.
- (d) Any defective or misadjusted components in the interlock, monitor, door seal, and microwave generation and transmission systems shall be repaired, replaced, or adjusted by procedures described in this manual before the oven is released to the owner.
- (e) A microwave leakage check to verify compliance with the Federal Performance Standard should be performed on each oven prior to releasing oven to the owner.

## **BEFORE SERVICING**

Before servicing an operative unit, perform a microwave emission check as per the Microwave Measurement Procedure outlined in this service manual.

If microwave emissions level is in excess of the specified limit, contact SHARP ELECTRONICS CORPORATION immediately @1-800-237-4277.

If the unit operates with the door open, service person should 1) tell the user not to operate the oven and 2) contact SHARP ELECTRONICS CORPORATION and Food and Drug Administration's Center for Devices and Radiological Health immediately.

Service personnel should inform SHARP ELECTRONICS CORPORATION of any certified unit found with emissions in excess of  $4\text{mW}/\text{cm}^2$ . The owner of the unit should be instructed not to use the unit until the oven has been brought into compliance.

## WARNING TO SERVICE PERSONNEL

Microwave ovens contain circuitry capable of producing very high voltage and current, contact with following parts may result in a severe, possibly fatal, electrical shock.

(Example)

High Voltage Capacitor, High Voltage Power Transformer, Magnetron, High Voltage Rectifier Assembly, High Voltage Harness etc..

Read the Service Manual carefully and follow all instructions.

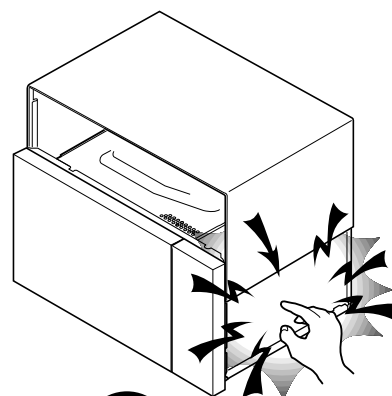

**Don't Touch !  
Danger High Voltage**

### Before Servicing



1. Disconnect the power supply cord , and then remove outer case.
2. Open the door and block it open.
3. Discharge high voltage capacitor.

**WARNING: RISK OF ELECTRIC SHOCK.  
DISCHARGE THE HIGH-VOLTAGE  
CAPACITOR BEFORE SERVICING.**

The high-voltage capacitor remains charged about 60 seconds after the oven has been switched off. Wait for 60 seconds and then short-circuit the connection of the high-voltage capacitor (that is the connecting lead of the high-voltage rectifier) against the chassis with the use of an insulated screwdriver.

Whenever troubleshooting is performed the power supply must be disconnected. It may in, some cases, be necessary to connect the power supply after the outer case has been removed, in this event,

1. Disconnect the power supply cord, and then remove outer case.
2. Open the door and block it open.
3. Discharge high voltage capacitor.
4. Disconnect the leads to the primary of the power transformer.
5. Ensure that the leads remain isolated from other components and oven chassis by using insulation tape.
6. After that procedure, reconnect the power supply cord.

### When the testing is completed,

1. Disconnect the power supply cord, and then remove outer case.
2. Open the door and block it open.
3. Discharge high voltage capacitor.
4. Reconnect the leads to the primary of the power transformer.
5. Reinstall the outer case (cabinet).
6. Reconnect the power supply cord after the outer case is installed.
7. Run the oven and check all functions.

### After repairing

1. Reconnect all leads removed from components during testing.
2. Reinstall the outer case (cabinet).
3. Reconnect the power supply cord after the outer case is installed.
4. Run the oven and check all functions.

Microwave ovens should not be run empty. To test for the presence of microwave energy within a cavity, place a cup of cold water on the oven turntable, close the door and set the power to HIGH and set the microwave timer for two (2) minutes. When the two minutes has elapsed (timer at zero) carefully check that the water is now hot. If the water remains cold carry out **Before Servicing** procedure and re-examine the connections to the component being tested.

When all service work is completed and the oven is fully assembled, the microwave power output should be checked and microwave leakage test should be carried out.

## MICROWAVE MEASUREMENT PROCEDURE

### A. Requirements:

- 1) Microwave leakage limit (Power density limit): The power density of microwave radiation emitted by a microwave oven should not exceed  $1\text{ mW/cm}^2$  at any point 5cm or more from the external surface of the oven, measured prior to acquisition by a purchaser, and thereafter (through the useful life of the oven),  $5\text{ mW/cm}^2$  at any point 5cm or more from the external surface of the oven.
- 2) Safety interlock switches Primary interlock relay and door sensing switch shall prevent microwave radiation emission in excess of the requirement as above mentioned, secondary interlock switch shall prevent microwave radiation emission in excess of  $5\text{ mW/cm}^2$  at any point 5cm or more from the external surface of the oven.

### B. Preparation for testing:

#### Before beginning the actual measurement of leakage, proceed as follows:

- 1) Make sure that the actual instrument is operating normally as specified in its instruction booklet.

#### Important:

Survey instruments that comply with the requirement for instrumentation as prescribed by the performance standard for microwave ovens, 21 CFR 1030.10(c)(3)(i), must be used for testing.

- 2) Place the oven tray in the oven cavity.
- 3) Place the load of  $275\pm 15\text{ ml}$  (9.8 oz) of tap water initially at  $20\pm 5^\circ\text{C}$  ( $68^\circ\text{F}$ ) in the center of the oven cavity. The water container shall be a low form of 600 ml (20 oz) beaker with an inside diameter of approx. 8.5 cm (3-1/2 in.) and made of an electrically nonconductive material such as glass or plastic. The placing of this standard load in the oven is important not only to protect the oven, but also to insure that any leakage is measured accurately.
- 4) Set the cooking control on Full Power Cooking Mode
- 5) Close the door and select a cook cycle of several minutes. If the water begins to boil before the survey is completed, replace it with 275 ml of cool water.

### C. Leakage test:

#### Closed-door leakage test (microwave measurement)

- 1) Grasp the probe of the survey instrument and hold it perpendicular to the gap between the door and the body of the oven.
- 2) Move the probe slowly, not faster than 1 in./sec. (2.5 cm/sec.) along the gap, watching for the maximum indication on the meter.
- 3) Check for leakage at the door screen, sheet metal seams and other accessible positions where the continuity of the metal has been breached (eg., around the switches, indicator, and vents).  
While testing for leakage around the door pull the door away from the front of the oven as far as is permitted by the closed latch assembly.
- 4) Measure carefully at the point of highest leakage and make sure that the highest leakage is no greater than  $4\text{ mW/cm}^2$ , and that the secondary interlock switch does turn the oven OFF before any door movement.

NOTE: After servicing, record data on service invoice and microwave leakage report.

# SERVICE MANUAL

## SHARP

### MICROWAVE OVEN

R-320BB / R-320BK / R-320BW

#### FOREWORD

This Manual has been prepared to provide Sharp Electronics Corp. Service Personnel with Operation and Service Information for the SHARP MICROWAVE OVEN, R-320BB, R-320BK, R-320BW.

It is recommended that service personnel carefully study the entire text of this manual so that they will be qualified to render satisfactory customer service.

Check the interlock switches and the door seal carefully. Special attention should be given to avoid electrical shock and microwave radiation hazard.

#### WARNING

Never operate the oven until the following points are ensured.

- (A) The door is tightly closed.
- (B) The door brackets and hinges are not defective.
- (C) The door packing is not damaged.
- (D) The door is not deformed or warped.
- (E) There is not any other visible damage with the oven.

Servicing and repair work must be carried out only by trained service personnel.

#### DANGER

**Certain initial parts are intentionally not grounded and present a risk of electrical shock only during servicing. Service personnel - Do not contact the following parts while the appliance is energized;**

**High Voltage Capacitor, Power Transformer, Magnetron, High Voltage Rectifier Assembly, High Voltage Harness;  
If provided, Vent Hood, Fan assembly, Cooling Fan Motor.**

All the parts marked "\*" on parts list are used at voltages more than 250V.

Removal of the outer wrap gives access to voltage above 250V.

All the parts marked "Δ" on parts list may cause undue microwave exposure, by themselves, or when they are damaged, loosened or removed.

PRODUCT DESCRIPTION

GENERAL INFORMATION

OPERATION

TROUBLESHOOTING GUIDE AND TEST PROCEDURE

TOUCH CONTROL PANEL

COMPONENT REPLACEMENT AND ADJUSTMENT PROCEDURE

WIRING DIAGRAM

PARTS LIST

SHARP ELECTRONICS CORPORATION

SHARP PLAZA, MAHWAH,  
NEW JERSEY 07430-2135

## SPECIFICATION

ITEM	DESCRIPTION
Power Requirements	120 Volts / 14 Amperes 60 Hertz Single phase, 3 wire grounded
Power Output	1100 watts (IEC-705 TEST PROCEDURE) Operating frequency of 2450MHz
Case Dimensions	Width 20-1/2" Height 11-7/8" Depth 15-7/8"
Cooking Cavity Dimensions  1.0 Cubic Feet	Width 13-3/4" Height 8-3/8" Depth 14-7/8"
Control Complement	Touch Control System Clock ( 1:00 - 12:59 ) Timer (0 - 99 min. 99 seconds) Microwave Power for Variable Cooking Repetition Rate; P-HI ..... Full power throughout the cooking time P-90 ..... approx. 90% of Full Power P-80 ..... approx. 80% of Full Power P-70 ..... approx. 70% of Full Power P-60 ..... approx. 60% of Full Power P-50 ..... approx. 50% of Full Power P-40 ..... approx. 40% of Full Power P-30 ..... approx. 30% of Full Power P-20 ..... approx. 20% of Full Power P-10 ..... approx. 10% of Full Power P-0 ..... No power throughout the cooking time  SENSOR COOK pads, INSTANT ACTION pads COMPU DEFROST pads, Number selection pads KITCHEN TIMER pad, AUTO START/CLOCK pad MINUTE PLUS pad, POWER LEVEL pad STOP/CLEAR pad, START pad
Oven Cavity Light	Yes
Safety Standard	UL Listed                      FCC Authorized DHHS Rules, CFR, Title 21, Chapter 1, Subchapter J

## GENERAL INFORMATION

### GROUNDING INSTRUCTIONS

This oven is equipped with a three prong grounding plug. It must be plugged into a wall receptacle that is properly installed and grounded in accordance with the National Electrical Code and local codes and ordinances.

In the event of an electrical short circuit, grounding reduces the risk of electric shock by providing an escape wire for the electric current.

**WARNING: Improper use of the grounding plug can result in a risk of electric shock.**

#### Electrical Requirements

The electrical requirements are a 115 -120 volt 60 Hz, AC only, 15 or 20 amp. fused electrical supply. It is recommended that a separate circuit serving only this appliance be provided. When installing this appliance, observe all applicable codes and ordinances.

A short power-supply cord is provided to reduce risks of becoming entangled in or tripping over a longer cord.

Where a two-pronged wall-receptacle is encountered, it is the personal responsibility and obligation of the customer to contact a qualified electrician and have it replaced with a properly grounded three-pronged wall receptacle or have a grounding adapter properly grounded and polarized. If the extension cord must be used, it should be a 3-wire, 15 amp. or higher rated cord. Do not drape over a countertop or table where it can be pulled on by children or tripped over accidentally.

**CAUTION: DO NOT UNDER ANY CIRCUMSTANCES CUT OR REMOVE THE ROUND GROUNDING PRONG FROM THIS PLUG.**

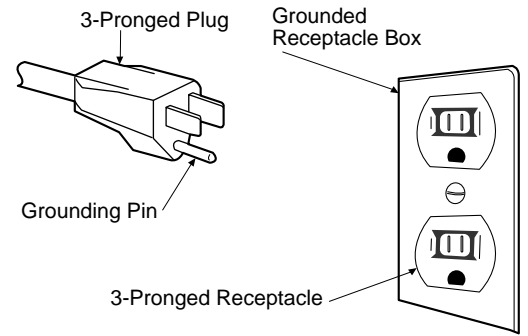

### OVEN DIAGRAM

1. One touch door open button.  
Push to open door.
2. Door latches.  
The oven will not operate unless the door is securely closed.
3. Removable turntable support.  
The turntable will rotate clockwise or counterclockwise.
5. Oven lamp.  
It will light when oven is operating or door is opened.
6. Oven door with see-through window.
7. Ventilation openings. (Rear)
8. Auto-Touch control panel.

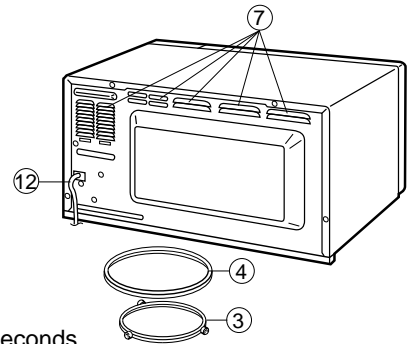
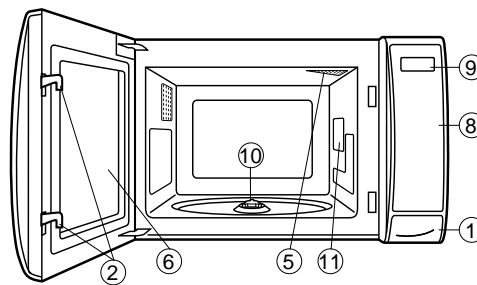

9. Time display: Digital display, 99 minutes 99 seconds.
10. Coupling.
11. Wave guide cover.
12. Power supply cord

### TOUCH CONTROL PANEL

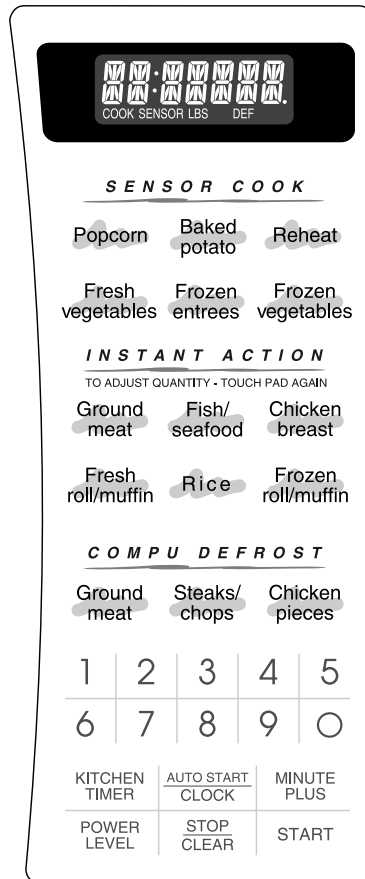

# OPERATION

## DESCRIPTION OF OPERATING SEQUENCE

The following is a description of component functions during oven operation.

### OFF CONDITION

Closing the door activates door sensing switch and secondary interlock switch. (In this condition, the monitor switch contacts are opened.)

When oven is plugged in, 120 volts A.C. is supplied to the control unit. (Figure O-1).

- The display will show flashing "88 : 88".  
To set any program or set the clock, you must first touch the STOP/CLEAR pad. The display will clear, and " : " will appear.

### COOKING CONDITION

Program desired cooking time by touching the NUMBER pads. Program the power level by touching the POWER LEVEL pad and then a Number pad.

When the START pad is touched, the following operations occur:

- The contacts of relays are closed and components connected to the relays are turned on as follows.  
(For details, refer to Figure O-2)

RELAY	CONNECTED COMPONENTS
RY-1	oven lamp/turntable motor/fan motor
RY-2	power transformer

- 120 volts A.C. is supplied to the primary winding of the power transformer and is converted to about 3.2 volts A.C. output on the filament winding, and approximately 2150 volts A.C. on the high voltage winding.
- The filament winding voltage heats the magnetron filament and the H.V. winding voltage is sent to a voltage doubler circuit.
- The microwave energy produced by the magnetron is channelled through the waveguide into the cavity feed-box, and then into the cavity where the food is placed to be cooked.
- Upon completion of the cooking time, the power transformer, oven lamp, etc. are turned off, and the generation of microwave energy is stopped. The oven will revert to the OFF condition.
- When the door is opened during a cook cycle, monitor switch, door sensing switch, secondary interlock switch, relay (RY1) and primary interlock relay are activated with the following results. The circuits to the turntable motor, the cooling fan motor, and the high voltage components are de-energized, the oven lamp remains on, and the digital read-out displays the time still remaining in the cook cycle when the door was opened.
- The monitor switch electrically monitors the operation of the secondary interlock switch and primary interlock relay and is mechanically associated with the door so

that it will function in the following sequence.

- When the door opens from the closed position, the primary interlock relay (RY2) and secondary interlock switch open their contacts. And contacts of the relay (RY1) remains closed. Then the monitor switch contacts close.
- When the door is closed from the open position, the monitor switch contacts open first. Then the contacts of the secondary interlock switch and door sensing switch close. And contacts of the relay (RY1) open.

If the secondary interlock switch and primary interlock relay (RY2) fail with the contacts closed when the door is opened, the closing of the monitor switch contacts will form a short circuit through the monitor fuse, secondary interlock switch, relay (RY1) and primary interlock relay (RY2), causing the monitor fuse to blow.

### POWER LEVEL P-0 TO P-90 COOKING

When Variable Cooking Power is programmed, the 120 volts A.C. is supplied to the power transformer intermittently through the contacts of relay (RY-2) which is operated by the control unit within a 32 second time base. Microwave power operation is as follows:

VARI-MODE	ON TIME	OFF TIME
Power 10(P-HI) (100% power)	32 sec.	0 sec.
Power 9(P-90) (approx. 90% power)	30 sec.	2 sec.
Power 8(P-80) (approx. 80% power)	26 sec.	6 sec.
Power 7(P-70) (approx. 70% power)	24 sec.	8 sec.
Power 6(P-60) (approx. 60% power)	22 sec.	10 sec.
Power 5(P-50) (approx. 50% power)	18 sec.	14 sec.
Power 4(P-40) (approx. 40% power)	16 sec.	16 sec.
Power 3(P-30) (approx. 30% power)	12 sec.	20 sec.
Power 2(P-20) (approx. 20% power)	8 sec.	24 sec.
Power 1(P-10) (approx. 10% power)	6 sec.	26 sec.
Power 0(P-0) (0% power)	0 sec.	32 sec.

Note: The ON/OFF time ratio does not correspond with the percentage of microwave power, because approx. 2 seconds are needed for heating of the magnetron filament.

### SENSOR COOKING CONDITION

Using the SENSOR function, the foods are cooked without figuring time, power level or quantity. When the oven senses

enough steam from the food, it relays the information to its microprocessor which will calculate the remaining cooking time and power level needed for best results. When the food is cooked, water vapor is developed. The sensor "senses" the vapor and its resistance increases gradually. When the resistance reaches the value set according to the menu, supplementary cooking is started. The time of supplementary cooking is determined by experiment with each food category and inputted into the LSI. An example of how sensor works: (POTATOES)



1. Potatoes at room temperature. Vapor is emitted very slowly.

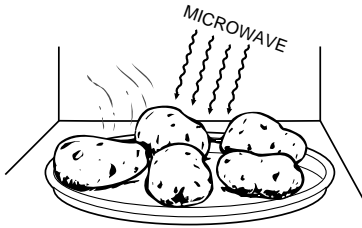

2. Heat Potatoes. Moisture and humidity is emitted rapidly. You can smell the aroma as it cooks.

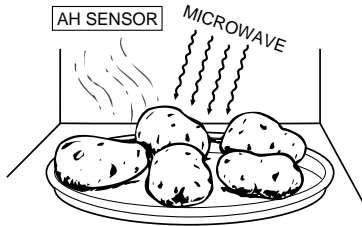

3. Sensor detects moisture and humidity and calculates cooking time and variable power.

**Cooking Sequence.**

1. Touch one of the SENSOR pads.

NOTE: The oven should not be operated on SENSOR immediately after plugging in the unit. Wait two minutes before cooking on SENSOR.

2. The coil of shut-off relay (RY-1) is energized, the turntable motor, oven lamp and cooling fan motor are turned on, but the power transformer is not turned on.

3. After about 16 seconds, the cook relay (RY-2) is energized. The power transformer is turned on, microwave energy is produced and first stage is started. The 16 seconds is the cooling time required to remove any vapor from the oven cavity and sensor.

NOTE: During this first stage, do not open the door or touch STOP/CLEAR pad.

4. When the sensor detects the vapor emitted from the food, the display switches over to the remaining cooking time and the timer counts down to zero.

At this time, the door may be opened to stir, turn, or season food.

5. When the timer reaches zero, an audible signal sounds. The shut-off relay and cook relay are de-energized and the power transformer, oven lamp, etc. are turned off.

6. Opening the door or touching the STOP/CLEAR pad, the time of day will reappear on the display and the oven will revert to an OFF condition.

**SCHEMATIC**  
NOTE: CONDITION OF OVEN  
1. DOOR CLOSED  
2. CLOCK APPEARS ON DISPLAY

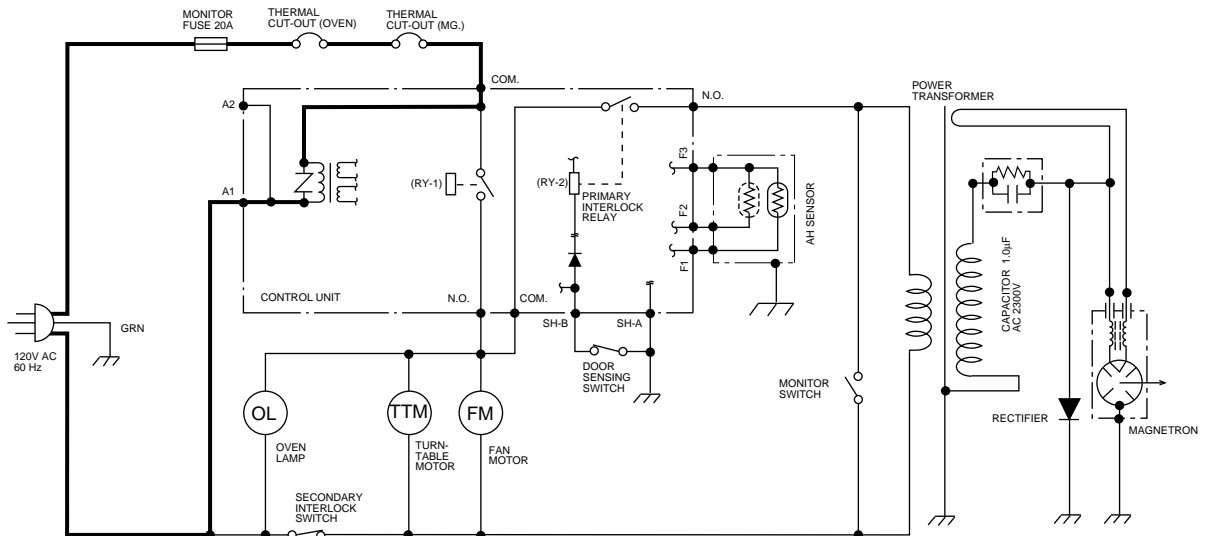
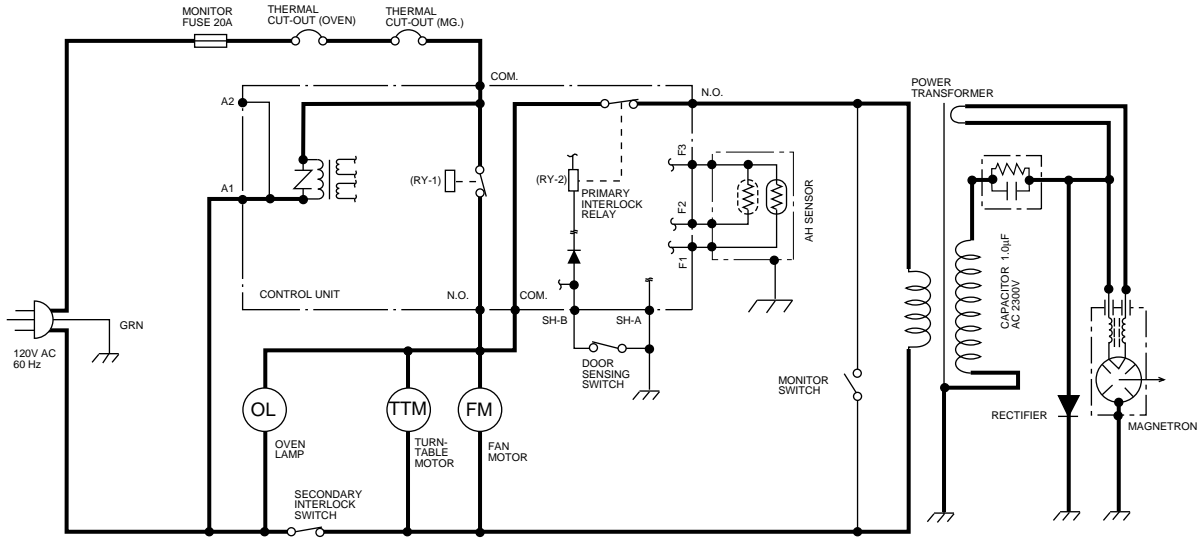

**Figure O-1. Oven Schematic-Off Condition**

**SCHEMATIC**

NOTE: CONDITION OF OVEN

1. DOOR CLOSED
2. COOKING TIME PROGRAMMED
3. VARIABLE COOKING CONTROL "HIGH"
4. "START" PAD TOUCHED



**Figure O-2. Oven Schematic-Cooking Condition**

## DESCRIPTION AND FUNCTION OF COMPONENTS

### DOOR OPEN MECHANISM

The door is opened by pushing the open button on the control panel, refer to the Figure D-1.

When the open button is pushed, the open button pushes up the switch lever, and then the switch lever pushes up the latch head. The latch heads are moved upward and released from latch hook. Now the door will open.

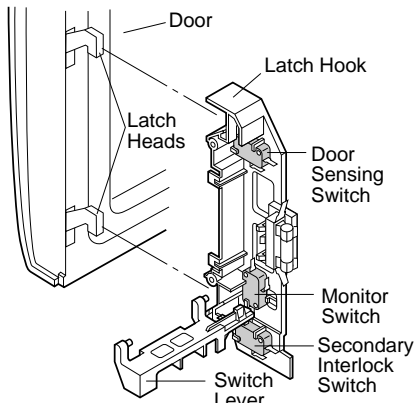

**Figure D-1. Door Open Mechanism**

### DOOR SENSING AND SECONDARY INTERLOCK SWITCHES

The secondary interlock switch is mounted in the lower position of the latch hook and the door sensing switch in the primary interlock system is mounted in the upper position of the latch hook. They are activated by the latch heads on the door. When the door is opened, the switches interrupt the power to all high voltage components. A cook cycle cannot

take place until the door is firmly closed thereby activating both interlock switches. The primary interlock system consists of the door sensing switch and primary interlock relay located on the control circuit board.

### MONITOR SWITCH

The monitor switch is activated (the contacts opened) by the latch head on the door while the door is closed. The switch is intended to render the oven inoperative, by means of blowing the monitor fuse, when the contacts of the primary interlock relay (RY2) and secondary interlock switch fail to open when the door is opened.

#### Functions:

1. When the door is opened, the monitor switch contact close (to the ON condition) due to their being normally closed. At this time the primary interlock relay (RY2) and secondary interlock switch are in the OFF condition (contacts open) due to their being normally open contact switches.
2. As the door goes to a closed position, the monitor switch contacts are first opened and then the door sensing switch and the secondary interlock switch contacts close. (On opening the door, each of these switches operate inversely.)
3. If the door is opened, and the primary interlock relay (RY2) and secondary interlock switch contacts fail to open, the monitor fuse blows simultaneously with closing of the monitor switch contacts.

**CAUTION: BEFORE REPLACING A BLOWN MONITOR FUSE TEST THE DOOR SENSING SWITCH,**

PRIMARY INTERLOCK RELAY (RY2), RELAY (RY1), SECONDARY INTERLOCK SWITCH AND MONITOR SWITCH FOR PROPER OPERATION. (REFER TO CHAPTER "TEST PROCEDURE").

**NOTE: MONITOR FUSE AND MONITOR SWITCH ARE REPLACED AS AN ASSEMBLY.**

### TURNTABLE MOTOR

The turntable motor rotates the turntable located on the bottom of the oven cavity, so that the foods on the turntable cook evenly during cooking. The turntable may turn in either direction.

### COOLING FAN MOTOR

The cooling fan motor drives a blade which draws external cool air. This cool air is directed through the air vanes surrounding the magnetron and cools the magnetron. This air is channelled through the oven cavity to remove steam and vapors given off from the heating foods. It is then exhausted through the exhausting air vents at the oven cavity.

### MONITOR FUSE

1. The monitor fuse blows when the contacts (COM-NO) of the primary interlock relay (RY2) and secondary interlock switch remain closed with the oven door open and when

the monitor switch closes.

2. If the wire harness or electrical components are short-circuited, this monitor fuse blows to prevent an electric shock or fire hazard.

### OVEN THERMAL CUT-OUT

The thermal cut-out, located on the top of the oven cavity, is designed to prevent damage to the oven by fire. If the foods load is overcooked, by either error in cook time or defect in the control unit, the thermal cut-out will open.

Under normal operation, the oven thermal cut-out remains closed. However, when abnormally high temperatures are reached within the oven cavity, the oven thermal cut-out will open at 257°F (125°C), causing the oven to shut down.

### MAGNETRON THERMAL CUT-OUT

The thermal cut-out located near the magnetron is designed to prevent damage to the magnetron if an over heated condition develops in the tube due to cooling fan failure, obstructed air guide, dirty or blocked air intake, etc.

Under normal operation, the thermal cut-out remains closed. However, when abnormally high temperatures are reached within the magnetron, the thermal cut-out will open at 338°F (170°C) causing the oven to shut down. When the magnetron has cooled to safe operating temperature, the thermal cut-out closes at 311°F (155°C) and the cook cycle will resume.

## TROUBLESHOOTING GUIDE

**Never touch any part in the circuit with your hand or an uninsulated tool while the power supply is connected.**

When troubleshooting the microwave oven, it is helpful to follow the Sequence of Operation in performing the checks. Many of the possible causes of trouble will require that a specific test be performed. These tests are given a procedure letter which will be found in the "Test Procedure" section.

**IMPORTANT:** If the oven becomes inoperative because of a blown monitor fuse, check the monitor switch, relay (RY1) primary interlock relay (RY2), door sensing switch and secondary interlock switch before replacing the monitor fuse. If monitor fuse is replaced, the monitor switch must also be replaced. Use part FFS-BA012WRK0 as an assembly.

**IMPORTANT:** Whenever troubleshooting is performed with the power supply cord disconnected. It may in, some cases, be necessary to connect the power supply cord after the outer case has been removed, in this event,

1. Disconnect the power supply cord, and then remove outer case.
2. Open the door and block it open.
3. Discharge high voltage capacitor.
4. Disconnect the leads to the primary of the power transformer.
5. Ensure that the leads remain isolated from other components and oven chassis by using insulation tape.
6. After that procedure, reconnect the power supply cord.

#### When the testing is completed

1. Disconnect the power supply cord, and then remove outer case.
2. Open the door and block it open.
3. Discharge high voltage capacitor.
4. Reconnect the leads to the primary of the power transformer.
5. Reinstall the outer case (cabinet).
6. Reconnect the power supply cord after the outer case is installed.
7. Run the oven and check all functions.

CONDITION	TEST PROCEDURE  PROBLEM	RE	RE	A	B	C	D	E	F	F	G	H	RE	RE	CK	I	CK	CK	CK	J	K	L	M	N
OFF CONDITION	Home fuse or circuit breaker blows when power cord is plugged into wall receptacle	○	○																					
	Monitor fuse blows when power cord is plugged into wall receptacle.		○						○	○	○					○								
	All letters and indicators do not appear in display when power cord is first plugged into wall outlet.		○					○				○				○						○		
	Display does not operate properly when STOP/CLEAR key is touched. (Buzzer should sound and ":" or time of day should appear in display.)		○							○							○				○			
	Oven lamp does not light when door is opened.		○						○	○			○	○			○					○		
COOKING CONDITION	Oven lamp does not go out when door is closed.								○												○			
	Oven lamp lights but fan motor and turntable motor do not operate.		○							○				○	○									
	Oven does not go into cook cycle when START pad is touched		○							○	○					○	○			○	○			
	Oven seems to be operating but little or no heat is produced in oven load. (Food incompletely cooked or not cooked at all at end of cook cycle.)		○	○	○	○	○			○						○		○						
	Oven goes into a cook cycle but extremely uneven heating is produced in oven load (food).		○												○	○	○	○						
	Oven does not cook properly when programmed for Cooking Power 5 mode. (Operates properly on Cooking Power 10 (HIGH) mode.)									○							○							
	Oven goes into COMPU DEFROST but food is not defrosted well.															○	○					○		
SENSOR COOKING CONDITION	AH sensor does not end during Sensor cooking condition. (Oven does not shut off after a cup of water is boiling by sensor cooking.)															○						○		
	Oven stops at 16 sec. after starting.		○																			○		

**TEST PROCEDURES**

PROCEDURE LETTER	COMPONENT TEST
------------------	----------------

**A MAGNETRON ASSEMBLY TEST**

1. Disconnect the power supply cord, and then remove outer case.
2. Open the door and block it open.
3. Discharge high voltage capacitor.

## TEST PROCEDURES

PROCEDURE LETTER	COMPONENT TEST
	<ol style="list-style-type: none"> <li>4. To test for an open filament, isolate the magnetron from the high voltage circuit. A continuity check across the magnetron filament leads should indicate less than 1 ohm.</li> <li>5. To test for a shorted magnetron, connect the ohmmeter leads between the magnetron filament leads and chassis ground. This test should indicate an infinite resistance. If there is little or no resistance the magnetron is grounded and must be replaced.</li> <li>6. Reconnect all leads removed from components during testing.</li> <li>7. Reinstall the outer case (cabinet).</li> <li>8. Reconnect the power supply cord after the outer case is installed.</li> <li>9. Run the oven and check all functions.</li> </ol> <p><b>MICROWAVE OUTPUT POWER</b></p> <p>The following test procedure should be carried out with the microwave oven in a fully assembled condition (outer case fitted).</p> <p><b>HIGH VOLTAGES ARE PRESENT DURING THE COOK CYCLE, SO EXTREME CAUTION SHOULD BE OBSERVED.</b></p> <p>Power output of the magnetron can be measured by performing a water temperature rise test. This test should only be used if above tests do not indicate a faulty magnetron and there is no defect in the following components or wiring: silicon rectifier, high voltage capacitor and power transformer. This test will require a 16 ounce (453cc) measuring cup and an accurate mercury thermometer or thermocouple type temperature tester. For accurate results, the following procedure must be followed carefully:</p> <ol style="list-style-type: none"> <li>1. Fill the measuring cup with 16 oz. (453cc) of tap water and measure the temperature of the water with a thermometer or thermocouple temperature tester. Stir the thermometer or thermocouple through the water until the temperature stabilizes. Record the temperature of the water.</li> <li>2. Place the cup of water in the oven. Operate oven at POWER 10(HIGH) selecting more than 60 seconds cook time. Allow the water to heat for 60 seconds, measuring with a stop watch, second hand of a watch or the digital read-out countdown.</li> <li>3. Remove the cup from the oven and again measure the temperature, making sure to stir the thermometer or thermocouple through the water until the maximum temperature is recorded.</li> <li>4. Subtract the cold water temperature from the hot water temperature. The normal result should be 32.6 to 64.6°F (18.1 to 33.7°C) rise in temperature. If the water temperatures are accurately measured and tested for the required time period the test results will indicate if the magnetron tube has low power output (low rise in water temperature) which would extend cooking time or high power output (high rise in water temperature) which would reduce cooking time. Because cooking time can be adjusted to compensate for power output, the magnetron tube assembly should be replaced only if the water temperature rise test indicates a power output well beyond the normal limits. The test is only accurate if the power supply line voltage is 120 volts and the oven cavity is clean.</li> </ol>

---

### **B      POWER TRANSFORMER TEST**

1. Disconnect the power supply cord, and then remove outer case.
2. Open the door and block it open.
3. Discharge high voltage capacitor.
4. Disconnect the primary input terminals and measure the resistance of the transformer with an ohmmeter. Check for continuity of the coils with an ohmmeter. On the R x 1 scale, the resistance of the primary coil should be less than 1 ohm and the resistance of the high voltage coil should be approximately 76 ohms; the resistance of the filament coil should be less than 1 ohm.
5. Reconnect all leads removed from components during testing.
6. Reinstall the outer case (cabinet).
7. Reconnect the power supply cord after the outer case is installed.
8. Run the oven and check all functions.

(HIGH VOLTAGES ARE PRESENT AT THE HIGH VOLTAGE TERMINAL, SO DO NOT ATTEMPT TO MEASURE THE FILAMENT AND HIGH VOLTAGE.)

## TEST PROCEDURES

PROCEDURE LETTER	COMPONENT TEST
<b>C</b>	<b><u>HIGH VOLTAGE RECTIFIER TEST</u></b> <ol style="list-style-type: none"><li>1. Disconnect the power supply cord, and then remove outer case.</li><li>2. Open the door and block it open.</li><li>3. Discharge high voltage capacitor.</li><li>4. Isolate the rectifier from the circuit. Using the highest ohm scale of the meter, read the resistance across the terminals and observe, reverse the leads to the rectifier terminals and observe meter reading. If a short is indicated in both directions, or if an infinite resistance is read in both directions, the rectifier is probably defective and should be replaced.</li><li>5. Reconnect all leads removed from components during testing.</li><li>6. Reinstall the outer case (cabinet).</li><li>7. Reconnect the power supply cord after the outer case is installed.</li><li>8. Run the oven and check all functions.</li></ol> <p><b>NOTE: Be sure to use an ohmmeter that will supply a forward bias voltage of more than 6.3 volts.</b></p>
<b>D</b>	<b><u>HIGH VOLTAGE CAPACITOR TEST</u></b> <ol style="list-style-type: none"><li>1. Disconnect the power supply cord, and then remove outer case.</li><li>2. Open the door and block it open.</li><li>3. Discharge high voltage capacitor.</li><li>4. If the capacitor is open, no high voltage will be available to the magnetron. Disconnect input leads and check for short or open between the terminals using an ohmmeter. Checking with a high ohm scale, if the high voltage capacitor is normal, the meter will indicate continuity for a short time and should indicate an open circuit once the capacitor is charged. If the above is not the case, check the capacitor with an ohmmeter to see if it is shorted between either of the terminals and case. If it is shorted, replace the capacitor.</li><li>5. Reconnect all leads removed from components during testing.</li><li>6. Reinstall the outer case (cabinet).</li><li>7. Reconnect the power supply cord after the outer case is installed.</li><li>8. Run the oven and check all functions.</li></ol>
<b>E</b>	<b><u>OVEN THERMAL CUT-OUT TEST</u></b> <ol style="list-style-type: none"><li>1. Disconnect the power supply cord, and then remove outer case.</li><li>2. Open the door and block it open.</li><li>3. Discharge high voltage capacitor.</li><li>4. A continuity check across the thermal cut-out terminals should indicate a closed circuit unless the temperature of the thermal cut-out reaches approximately 257°F(125°C). An open thermal cut-out indicates overheating of the oven, exchange the oven thermal cut-out and check inside of oven cavity and for improper setting of cooking time or operation of control unit. Check for restricted air flow through the vent holes of the oven cavity, especially the cooling fan and air guide.</li><li>5. Reconnect all leads removed from components during testing.</li><li>6. Reinstall the outer case (cabinet).</li><li>7. Reconnect the power supply cord after the outer case is installed.</li><li>8. Run the oven and check all functions.</li></ol> <b><u>MAGNETRON THERMAL CUT-OUT TEST</u></b> <ol style="list-style-type: none"><li>1. Disconnect the power supply cord, and then remove outer case.</li><li>2. Open the door and block it open.</li><li>3. Discharge high voltage capacitor.</li><li>4. A continuity check across the thermal cut-out terminals should indicate a closed circuit. If the temperature of the magnetron reaches approximately 338°F(170°C), the thermal cut-out opens. The thermal cut-out resets automatically below approximately 311°F(155°C). An open thermal cut-out indicates overheating of the magnetron. Check for restricted air flow to the magnetron, especially the cooling fan air guide.</li><li>5. Reconnect all leads removed from components during testing.</li><li>6. Reinstall the outer case (cabinet).</li><li>7. Reconnect the power supply cord after the outer case is installed.</li></ol>

**TEST PROCEDURES**

<b>PROCEDURE LETTER</b>	<b>COMPONENT TEST</b>
	<p>8. Run the oven and check all functions.</p> <p>CAUTION: IF THE THERMAL CUT-OUT INDICATES AN OPEN CIRCUIT AT ROOM TEMPERATURE, REPLACE THERMAL CUT-OUT.</p>
<b>F</b>	<p><b><u>SECONDARY INTERLOCK SWITCH TEST</u></b></p> <ol style="list-style-type: none"><li>1. Disconnect the power supply cord, and then remove outer case.</li><li>2. Open the door and block it open.</li><li>3. Discharge high voltage capacitor.</li><li>4. Isolate the switch and connect the ohmmeter to the common (COM.) and normally open (NO) terminal of the switch. The meter should indicate an open circuit with the door open and a closed circuit with the door closed. If improper operation is indicated, replace the secondary interlock switch.</li><li>5. Reconnect all leads removed from components during testing.</li><li>6. Reinstall the outer case (cabinet).</li><li>7. Reconnect the power supply cord after the outer case is installed.</li><li>8. Run the oven and check all functions.</li></ol> <p><b><u>PRIMARY INTERLOCK SYSTEM TEST</u></b></p> <p><b><u>DOOR SENSING SWITCH</u></b></p> <ol style="list-style-type: none"><li>1. Disconnect the power supply cord, and then remove outer case.</li><li>2. Open the door and block it open.</li><li>3. Discharge high voltage capacitor.</li><li>4. Isolate the switch and connect the ohmmeter to the common (COM.) and normally open (NO) terminal of the switch. The meter should indicate an open circuit with the door open and a closed circuit with the door closed. If improper operation is indicated, replace the door sensing switch.</li><li>5. Reconnect all leads removed from components during testing.</li><li>6. Reinstall the outer case (cabinet).</li><li>7. Reconnect the power supply cord after the outer case is installed.</li><li>8. Run the oven and check all functions.</li></ol> <p>NOTE: If the door sensing switch contacts fail in the open position and the door is closed, the cooling fan, turntable and oven light will be activated by RY1.</p> <p><b><u>PRIMARY INTERLOCK RELAY (RY2)</u></b></p> <ol style="list-style-type: none"><li>1. Disconnect the power supply cord, and then remove outer case.</li><li>2. Open the door and block it open.</li><li>3. Discharge high voltage capacitor.</li><li>4. Disconnect two (2) wire leads from the male tab terminals of the Primary Interlock Relay. Check the state of the relay contacts using a ohmmeter. The relay contacts should be open. If the relay contacts are closed, replace the circuit board entirely or the relay itself.</li><li>5. Reconnect all leads removed from components during testing.</li><li>6. Reinstall the outer case (cabinet).</li><li>7. Reconnect the power supply cord after the outer case is installed.</li><li>8. Run the oven and check all functions.</li></ol>
<b>G</b>	<p><b><u>MONITOR SWITCH TEST</u></b></p> <ol style="list-style-type: none"><li>1. Disconnect the power supply cord, and then remove outer case.</li><li>2. Open the door and block it open.</li><li>3. Discharge high voltage capacitor.</li><li>4. Before performing this test, make sure that the secondary interlock switch and the primary interlock relay are operating properly, according to the above Switch Test Procedure. Disconnect the wire lead from the monitor switch (COM) terminal. Check the monitor switch operation by using the ohmmeter as follows. When the door is open, the meter should indicate a closed circuit. When the monitor switch actuator is pushed by a screw driver through the lower latch hole on the front plate of the oven cavity with the door opened (in this condition the plunger of the monitor switch is pushed in), the meter should indicate an open circuit. If improper operation is indicated, the switch may be defective. After testing the monitor switch, reconnect the wire lead to the monitor switch (COM) terminal and check the</li></ol>

## TEST PROCEDURES

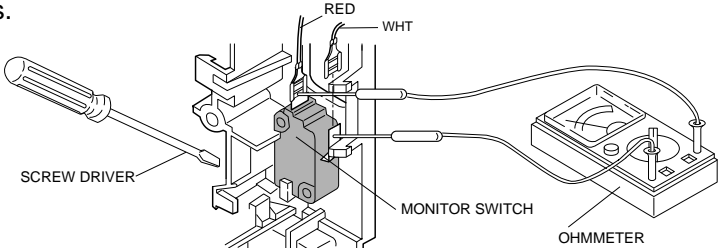
PROCEDURE LETTER	COMPONENT TEST
	<p>continuity of the monitor circuit.</p> <ol style="list-style-type: none"> <li>5. Reconnect all leads removed from components during testing.</li> <li>6. Reinstall the outer case (cabinet).</li> <li>7. Reconnect the power supply cord after the outer case is installed.</li> <li>8. Run the oven and check all functions.</li> </ol> 
<b>H</b>	<p><b><u>BLOWN MONITOR FUSE TEST</u></b></p> <ol style="list-style-type: none"> <li>1. Disconnect the power supply cord, and then remove outer case.</li> <li>2. Open the door and block it open.</li> <li>3. Discharge high voltage capacitor.</li> <li>4. If the monitor fuse is blown when the door is opened, check the primary interlock relay, secondary interlock switch and monitor switch according to the "TEST PROCEDURE" for those switches before replacing the blown monitor fuse.</li> </ol> <p><b>CAUTION: BEFORE REPLACING A BLOWN MONITOR FUSE, TEST THE PRIMARY INTERLOCK RELAY, SECONDARY INTERLOCK SWITCH, DOOR SENSING SWITCH AND MONITOR SWITCH FOR PROPER OPERATION.</b></p> <p>If the monitor fuse is blown by improper switch operation, the monitor fuse and monitor switch must be replaced with "monitor fuse and monitor switch assembly" part number FFS-BA012WRK0, even if the monitor switch operates normally. The monitor fuse and monitor switch assembly is comprised of a 20 ampere fuse and switch.</p> <ol style="list-style-type: none"> <li>5. Reconnect all leads removed from components during testing.</li> <li>6. Reinstall the outer case (cabinet).</li> <li>7. Reconnect the power supply cord after the outer case is installed.</li> <li>8. Run the oven and check all functions.</li> </ol>
<b>I</b>	<p><b><u>TOUCH CONTROL PANEL ASSEMBLY TEST</u></b></p> <p>The touch control panel consists of circuits including semiconductors such as LSI, ICs, etc. Therefore, unlike conventional microwave ovens, proper maintenance cannot be performed with only a voltmeter and ohmmeter. In this service manual, the touch control panel assembly is divided into two units, Control Unit and Key Unit, and also the Control Unit is divided into two units, CPU Unit and Power Unit, and troubleshooting by unit replacement is described according to the symptoms indicated.</p> <p><b>Before testing,</b></p> <ol style="list-style-type: none"> <li>1) Disconnect the power supply cord, and then remove outer case.</li> <li>2) Open the door and block it open.</li> <li>3) Discharge high voltage capacitor.</li> <li>4) Disconnect the leads to the primary of the power transformer.</li> <li>5) Ensure that these leads remain isolated from other components and oven chassis by using insulation tape.</li> <li>6) After that procedure, re-connect the power supply cord.</li> </ol> <ol style="list-style-type: none"> <li>1. Key Unit.             <p>NOTE ;</p> <ol style="list-style-type: none"> <li>1) Disconnect the power supply cord, and then remove outer case.</li> <li>2) Open the door and block it open.</li> <li>3) Discharge high voltage capacitor.</li> <li>4) Check Key unit ribbon connection before replacement.</li> <li>5) Reconnect all leads removed from components during testing.</li> <li>6) Re-install the outer case (cabinet).</li> </ol> </li> </ol>

## TEST PROCEDURES

PROCEDURE LETTER	COMPONENT TEST
	<p>7) Reconnect the power supply cord after the outer case is installed.</p> <p>8) Run the oven and check all functions.</p> <p>The following symptoms indicate a defective key unit.</p> <p>a) When touching the pads, a certain pad produces no signal at all.</p> <p>b) When touching a number pad, two figures or more are displayed.</p> <p>c) When touching the pads, sometimes a pad produces no signal.</p> <p>If the Key unit is defective.</p> <p>1) Disconnect the power supply cord, and then remove outer case.</p> <p>2) Open the door and block it open.</p> <p>3) Discharge high voltage capacitor.</p> <p>4) Replace the Key unit.</p> <p>5) Reconnect all leads removed from components during testing.</p> <p>6) Re-install the outer case (cabinet).</p> <p>7) Reconnect the power supply cord after the outer case is installed.</p> <p>8) Run the oven and check all functions.</p> <p>2. Control Unit</p> <p>The following symptoms indicate a defective control unit. Before replacing the control unit, perform the Key unit test (Procedure J) to determine if control unit is faulty.</p> <p>2-1 In connection with pads.</p> <p>a) When touching the pads, a certain group of pads do not produce a signal.</p> <p>b) When touching the pads, no pads produce a signal.</p> <p>2-2 In connection with indicators</p> <p>a) At a certain digit, all or some segments do not light up.</p> <p>b) At a certain digit, brightness is low.</p> <p>c) Only one indicator does not light.</p> <p>d) The corresponding segments of all digits do not light up; or they continue to light up.</p> <p>e) Wrong figure appears.</p> <p>f) A certain group of indicators do not light up.</p> <p>g) The figure of all digits flicker.</p> <p>2-3 Other possible problems caused by defective control unit.</p> <p>a) Buzzer does not sound or continues to sound.</p> <p>b) Clock does not operate properly.</p> <p>c) Cooking is not possible.</p> <p>When testing is completed,</p> <p>1) Disconnect the power supply cord, and then remove outer case.</p> <p>2) Open the door and block it open.</p> <p>3) Discharge high voltage capacitor.</p> <p>4) Reconnect all leads removed from components during testing.</p> <p>5) Re-install the outer case (cabinet).</p> <p>6) Reconnect the power supply cord after the outer case is installed.</p> <p>7) Run the oven and check all functions.</p>

**J****KEY UNIT TEST**

1. Disconnect the power supply cord, and then remove outer case.
2. Open the door and block it open.
3. Discharge high voltage capacitor.
4. If the display fails to clear when the STOP/CLEAR pad is depressed, first verify the flat ribbon cable is making good contact, verify that the door sensing switch (stop switch) operates properly; that is the contacts are closed when the door is closed and open when the door is open. If the door sensing switch (stop switch) is good, disconnect the flat ribbon cable that connects the key unit to the control unit and make sure the door sensing switch is closed (either close the door or short the door sensing switch connector). Use the Key unit matrix indicated on the control panel schematic and place a jumper wire between the pins that correspond to the STOP/CLEAR pad making momentary contact. If the control unit responds by clearing with a beep the key unit is faulty and must be replaced. If the control unit does not respond, it is a faulty and must be replaced. If a specific pad does not respond,

## TEST PROCEDURES

PROCEDURE LETTER	COMPONENT TEST
------------------	----------------

the above method may be used (after clearing the control unit) to determine if the control unit or key pad is at fault.

5. Reconnect all leads removed from components during testing.
6. Re-install the outer case (cabinet).
7. Reconnect the power supply cord after the outer case is installed.
8. Run the oven and check all functions.

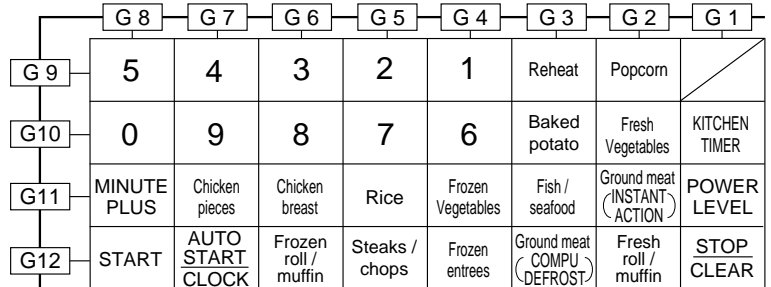

### K RELAY TEST

1. Disconnect the power supply cord, and then remove outer case.
2. Open the door and block it open.
3. Discharge high voltage capacitor.
4. Disconnect the leads to the primary of the power transformer.
5. Ensure that these leads remain isolated from other components and oven chassis by using insulation tape.
6. After that procedure, re-connect the power supply cord.
7. Remove the outer case and check voltage between Pin No. 1 of the 2 pin connector (A) and the common terminal of the relay RY1 on the control unit with an A.C. voltmeter.  
The meter should indicate 120 volts, if not check oven circuit.

#### RY1 and RY2 Relay Test

These relays are operated by D.C. voltage

Check voltage at the relay coil with a D.C. voltmeter during the microwave cooking operation.

DC. voltage indicated ..... Defective relay.

DC. voltage not indicated ..... Check diode which is connected to the relay coil. If diode is good, control unit is defective.

RELAY SYMBOL	OPERATIONAL VOLTAGE	CONNECTED COMPONENTS
RY1	Approx. 24.0V D.C.	Oven lamp / Turntable motor / Cooling fan motor
RY2	Approx. 23.0V D.C.	Power transformer

8. Disconnect the power supply cord, and then remove outer case.
9. Open the door and block it open.
10. Discharge high voltage capacitor.
11. Reconnect all leads removed from components during testing.
12. Re-install the outer case (cabinet).
13. Reconnect the power supply cord after the outer case is installed.
14. Run the oven and check all functions.

### L COMPU DEFROST TEST

**WARNING :** The oven should be fully assembled before following procedure.

- (1) Place one cup of water in the center of the turntable tray in the oven cavity.
- (2) Close the door, touch the " Steaks / chops " pad once.
- (3) The oven is in Compu Defrost cooking condition.
- (4) The oven will operate as follows

WEIGHT	1ST STAGE		2ND STAGE		3RD STAGE	
	LEVEL	TIME	LEVEL	TIME	LEVEL	TIME
0.5lb	50%	40sec.	30%	37sec.	20%	42sec.

- (5) If improper operation is indicated, the control unit is probably defective and should be checked.

## TEST PROCEDURES

PROCEDURE LETTER	COMPONENT TEST
<b>M</b>	<b><u>FOIL PATTERN ON THE PRINTED WIRING BOARD TEST</u></b>

To protect the electronic circuits, this model is provided with a fine foil pattern added to the primary on the PWB, this foil pattern acts as a fuse.

1. Foil pattern check and repairs.

- 1) Disconnect the power supply cord, and then remove outer case.
- 2) Open the door and block it open.
- 3) Discharge high voltage capacitor.
- 4) Follow the troubleshooting guide given below for repair.

STEPS	OCCURRENCE	CAUSE OR CORRECTION
1	Only pattern at "a" is broken.	*Insert jumper wire J1 and solder.
2	Pattern at "a" and "b" are broken.	*Insert the coil RCILF2003YAZZ between "c" and "d".

- 5) Make a visual inspection of the varistor. Check for burned damage and examine the transformer with a tester for the presence of layer short-circuit (check the primary coil resistance which is approximately  $212\Omega \pm 10\%$ ). If any abnormal condition is detected, replace the defective parts.

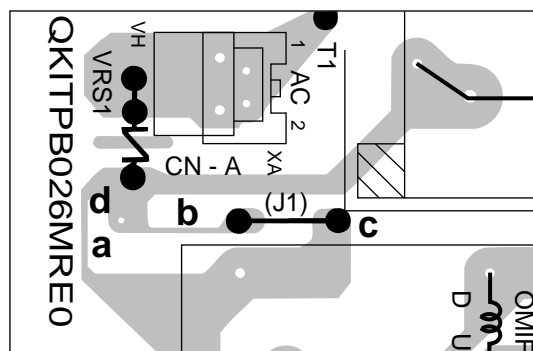

- 6) Reconnect all leads removed from components during testing.
- 7) Re-install the outer case (cabinet).
- 8) Reconnect the power supply cord after the outer case is installed.
- 9) Run the oven and check all functions.

2. Follow the troubleshooting guide given below, if indicator does not light up after above check and repairs are finished.

- 1) Disconnect the power supply cord, and then remove outer case.
- 2) Open the door and block it open.
- 3) Discharge high voltage capacitor.
- 4) Disconnect the leads to the primary of the power transformer.
- 5) Ensure that these leads remain isolated from other components and oven chassis by using insulation tape.
- 6) After that procedure, re-connect the power supply cord.
- 7) Follow the troubleshooting guide given below for repair.

STEPS	OCCURRENCE	CAUSE OR CORRECTION
1	The rated AC voltage is not present between Pin No. 1 of the 2-pin connector (A) and the common terminal of the relay RY1.	Check supply voltage and oven power cord.
2	The rated AC voltage is present at primary side of low voltage transformer.	Low voltage transformer or secondary circuit defective. Check and repair.

- 8) Disconnect the power supply cord, and then remove outer case.
- 9) Open the door and block it open.
- 10) Discharge high voltage capacitor.
- 11) Reconnect all leads removed from components during testing.
- 12) Re-install the outer case (cabinet).
- 13) Reconnect the power supply cord after the outer case is installed.
- 14) Run the oven and check all functions.

## TEST PROCEDURES

PROCEDURE LETTER	COMPONENT TEST
N	<b>AH SENSOR TEST</b>
	<p><b>Checking the initial sensor cooking condition</b></p> <p><b>WARNING :</b> The oven should be fully assembled before following procedure.</p> <ol style="list-style-type: none"><li>(1) The oven should be plugged in at least two minutes before sensor cooking.</li><li>(2) Room temperature should not exceed 95°F (35°C).</li><li>(3) The unit should not be installed in any area where heat and steam are generated. The unit should not be installed, for example, next to a conventional surface unit. Refer to the "INSTALLATION INSTRUCTIONS" of the operation manual.</li><li>(4) Exhaust vents are provided on the back of the unit for proper cooling and air flow in the cavity. To permit adequate ventilation, be sure to install so as not to block these vents. There should be some space for air circulation.</li><li>(5) Be sure the exterior of the cooking container and the interior of the oven are dry. Wipe off any moisture with a dry cloth or paper towel.</li><li>(6) The Sensor works with food at normal storage temperature. For example, chicken pieces would be at refrigerator temperature and canned soup at room temperature.</li><li>(7) Avoid using aerosol sprays or cleaning solvents near the oven while using Sensor settings. The sensor will detect the vapor given off by the spray and turn off before food is properly cooked.</li><li>(8) If the sensor has not detected the vapor of the food, ERROR will appear and the oven will shut off.</li></ol> <p><b>Water load cooking test</b></p> <p><b>WARNING :</b> The oven should be fully assembled before following procedure.</p> <p>Make sure the oven has been plugged in at least two minutes before checking sensor cook operation. The cabinet should be installed and screws tightened.</p> <ol style="list-style-type: none"><li>(1) Fill approximately 200 milliliters (7.2 oz) of tap water in a 1000 milliliter measuring cup.</li><li>(2) Place the container on the center of tray in the oven cavity.</li><li>(3) Close the door.</li><li>(4) Touch Reheat pad once. Now, the oven is in the sensor cooking condition and "REHEAT" will appear in the display.</li><li>(5) The oven will operate for the first 16 seconds, without generating microwave energy.</li></ol> <p>NOTE: ERROR will appear if the door is opened or STOP/CLEAR pad is touched during first stage of sensor cooking.</p> <ol style="list-style-type: none"><li>(6) After approximately 16 seconds, microwave energy is produced, and the display should start to count down the remaining cooking time and oven should turn off after water is boiling (bubbling).</li></ol> <p>If the oven does not turn off, replace the AH sensor or check the control unit, refer to explanation below.</p>
	<b><u>TESTING METHOD FOR AH SENSOR AND/OR CONTROL UNIT</u></b>
	<p>To determine if the sensor is defective, the simplest method is to replace it with a new replacement sensor.</p> <ol style="list-style-type: none"><li>(1) Disconnect the power supply cord, and then remove outer case.</li><li>(2) Open the door and block it open.</li><li>(3) Discharge high voltage capacitor.</li><li>(4) Remove the AH sensor.</li><li>(5) Install the new AH sensor.</li><li>(6) Reconnect all leads removed from components during testing.</li><li>(7) Re-install the outer case (cabinet).</li><li>(8) Reconnect the power supply cord after the outer case is installed.</li><li>(9) Reconnect the oven to the power supply and check the sensor cook operation as follows:<ol style="list-style-type: none"><li>9-1. Fill approximately 200 milliliters (7.2 oz) of tap water in a 1000 milliliter measuring cup.</li><li>9-2. Place the container on the center of tray in the oven cavity.</li><li>9-3. Close the door.</li><li>9-4. Touch Reheat pad once.</li><li>9-5. The control panel is in automatic Sensor operation.</li><li>9-6. The display will start to count down the remaining cooking time, and the oven will turn off automatically after the water is boiling (bubbling).</li></ol></li></ol> <p>If new sensor does not operate properly, the problem is with the control unit, and refer to explanation below.</p>

## TEST PROCEDURES

PROCEDURE  
LETTER

## COMPONENT TEST

CHECKING CONTROL UNIT

- (1) Disconnect the power supply cord, and then remove outer case.
- (2) Open the door and block it open.
- (3) Discharge high voltage capacitor.
- (4) Disconnect the sensor connector that is mounted to control panel.
- (5) Then connect the dummy resistor circuit (see fig.) to the sensor connector of control panel.
- (6) Disconnect the leads to the primary of the power transformer.
- (7) Ensure that these leads remain isolated from other components and oven chassis by using insulation tape.
- (8) After that procedure, re-connect the power supply cord.
- (9) Check the sensor cook operation proceed as follows:
  - 9-1. Touch Reheat pad once.
  - 9-2. The control panel is in the sensor cooking operation.
  - 9-3. After approximately 20 seconds, push plunger of select switch for more than 3 seconds. This condition is same as judgement by AH sensor.
  - 9-4. After approximately 3 seconds, the display shows " X X . X X " which is the remaining cooking time, and the display count down.

If the above is not the case, the control unit is probably defective.  
If the above is proper, the AH sensor is probably defective.
- (10) Disconnect the power supply cord, and then remove outer case.
- (11) Open the door and block it open.
- (12) Discharge high voltage capacitor.
- (13) Disconnect the dummy resistor circuit from the sensor connector of control panel.
- (14) Carry out necessary repair.
- (15) Reconnect all leads removed from components during testing and repairing.
- (16) Re-install the outer case (cabinet).
- (17) Reconnect the power supply cord after the outer case is installed. Run the oven and check all functions.
- (18) Carry out "Water load cooking test" again and ensure that the oven works properly.

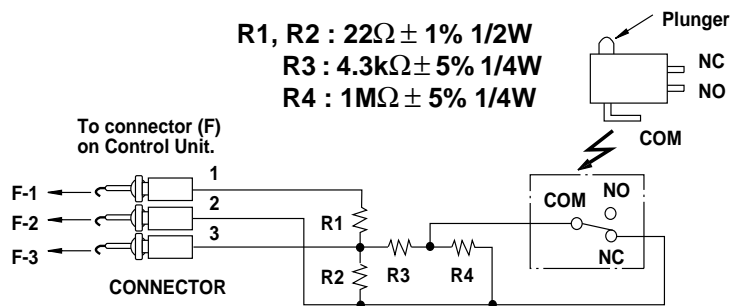

Sensor Dummy Resistor Circuit

# TOUCH CONTROL PANEL ASSEMBLY

## OUTLINE OF TOUCH CONTROL PANEL

The touch control section consists of the following units.

- (1) Key Unit
- (2) Control Unit (The Control Unit consists of Power Unit and LSI Unit).

The principal functions of these units and the signals communicated among them are explained below.

### Key Unit

The key unit is composed of a matrix, signals generated in the LSI are sent to the key unit through P20, P21, P22, P23, P24, P25, P26 and P27.

When a key pad is touched, a signal is completed through the key unit and passed back to the LSI through P43, P44, P45 and P46 to perform the function that was requested.

### Control Unit

Control unit consists of LSI, ACL circuit, indicator circuit, power source circuit, relay circuit, buzzer circuit, synchronizing signal circuit, absolute humidity sensor circuit and back light circuit.

#### 1) ACL

This circuit generates a signal which resets the LSI to the initial state when power is supplied.

#### 2) Indicator Circuit

This circuit consists of 25 segments and 4 common electrodes using a Liquid Crystal Display.

#### 3) Power Source Circuit

This circuit generates voltages necessary in the control unit from the AC line voltage.

In addition, the synchronizing signal is available in order to compose a basic standard time in the clock circuit.

Symbol	Voltage	Application
VC	-5V	LSI(IC1)

#### 4) Relay Circuit

A circuit to drive the magnetron, fan motor, turntable motor and light the oven lamp.

#### 5) Buzzer Circuit

The buzzer is responsive to signals from the LSI to emit audible sounds (key touch sound and completion sound).

#### 6) Synchronizing Signal Circuit

The power source synchronizing signal is available in order to compose a basic standard time in the clock circuit.

It accompanies a very small error because it works on commercial frequency.

#### 7) Door Sensing Switch

A switch to "tell" the LSI if the door is open or closed.

#### 8) Back Light Circuit

A circuit to drive the back light (Light emitting diodes LD1-LD5).

#### 9) Absolute Humidity Sensor Circuit

This circuit detects moisture of the cooking food to allow its automatic cooking.

**LSI(IZA865DR)**

The I/O signal of the LSI(IZA865DR) is detailed in the following table.

Pin No.	Signal	I/O	Description
1-2	VL2-VL1	IN	<b>Power source voltage input terminal.</b> Standard voltage for LCD.
3-6	AN7-AN4	IN	<b>Terminal to change cooking input according to the Model.</b> By using the A/D converter contained in the LSI, DC voltage in accordance with the Model in operation is applied to set up its cooking constant.
7	AN3	OUT	Terminal not used.
8	AN2	IN	<b>To input signal which communicates the door open/close information to LSI.</b> Door close "H" level signal (0V). Door open "L" level signal (-5V).
9	AN1	IN	<b>AH sensor input.</b> This input is an analog input terminal from the AH sensor circuit, and connected to the A/D converter built into the LSI.
10	AN0	IN	Used for initial balancing of the bridge circuit (absolute humidity sensor). This input is an analog input terminal from the AH sensor circuit, and connected to the A/D converter built into the LSI.
11-13	P57-P55	OUT	Used for initial balancing of the bridge circuit (absolute humidity sensor).
14	P54	OUT	<b>Signal to sound buzzer (2.0 kHz).</b> A: key touch sound. B: Completion sound.
15	P53	OUT	Used for initial balancing of the bridge circuit (absolute humidity sensor).
16	P52	OUT	<b>Oven lamp, fan motor and turntable motor driving signal</b> To turn on and off shut off relay (RY1). The square waveform voltage is delivered to the RY1 driving circuit and RY2 control circuit.
17	P51	OUT	Used for initial balancing of the bridge circuit (absolute humidity sensor).
18	P50	OUT	Terminal not used.
19	P47	OUT	<b>Magnetron high-voltage circuit driving signal.</b> To turn on and off the cook relay (RY2). The signals holds "L" level during microwave cooking and "H" level while not cooking. In other cooking modes (variable cooking) the signal turns to "H" level and "L" level in repetition according to the power level.
			<p>(ON and OFF times for other power level.)</p>
20	P46	IN	<b>Signal coming from touch key.</b> When either G12 line on key matrix is touched, a corresponding signal out of P20 - P27 will be input into P46. When no key is touched, the signal is held at "H" level.
21	P45	IN	<b>Signal similar to P46.</b> When either G11 line on key matrix is touched, a corresponding signal will be input into P45.
22	P44	IN	<b>Signal similar to P46.</b> When either G10 line on key matrix is touched, a corresponding signal will be input into P44.
23	P43	IN	<b>Signal similar to P46.</b> When either G9 line on key matrix is touched, a corresponding signal will be input into P43.
24	INT0	IN	<b>Signal synchronized with commercial power source frequency.</b> This is the basic timing for time processing of LSI.

Pin No.	Signal	I/O	Description																																																								
25	P41	OUT	Terminal not used.																																																								
26	P40	IN	Connected to VC.																																																								
27	RESET	IN	<b>Auto clear terminal.</b> Signal is input to reset the LSI to the initial state when power is applied. Temporarily set "L" level the moment power is applied, at this time the LSI is reset. Thereafter set at "H" level.																																																								
28-29	P71-P70	OUT	Terminal not used.																																																								
30	XIN	IN	<b>Internal clock oscillation frequency input setting.</b> The internal clock frequency is set by inserting the ceramic filter oscillation circuit with respect to XIN terminal.																																																								
31	XOUT	OUT	<b>Internal clock oscillation frequency control output.</b> Output to control oscillation input of XOUT.																																																								
32	VSS	IN	<b>Power source voltage: -5.0V.</b> VC voltage of power source circuit input.																																																								
33	P27	OUT	<b>Key strobe signal.</b> Signal applied to touch-key section. A pulse signal is input to P43 - P46 terminal while one of G8 line keys on key matrix is touched.																																																								
34	P26	OUT	<b>Key strobe signal.</b> Signal applied to touch-key section. A pulse signal is input to P43 - P46 terminal while one of G7 line keys on key matrix is touched.																																																								
35	P25	OUT	<b>Key strobe signal.</b> Signal applied to touch-key section. A pulse signal is input to P43 - P46 terminal while one of G6 line keys on key matrix is touched.																																																								
36	P24	OUT	<b>Key strobe signal.</b> Signal applied to touch-key section. A pulse signal is input to P43 - P46 terminal while one of G5 line keys on key matrix is touched.																																																								
37	P23	OUT	<b>Key strobe signal.</b> Signal applied to touch-key section. A pulse signal is input to P43 - P46 terminal while one of G4 line keys on key matrix is touched.																																																								
38	P22	OUT	<b>Key strobe signal.</b> Signal applied to touch-key section. A pulse signal is input to P43 - P46 terminal while one of G3 line keys on key matrix is touched.																																																								
39	P21	OUT	<b>Key strobe signal.</b> Signal applied to touch-key section. A pulse signal is input to P43 - P46 terminal while one of G2 line keys on key matrix is touched.																																																								
40	P20	OUT	<b>Key strobe signal.</b> Signal applied to touch-key section. A pulse signal is input to P43 - P46 terminal while one of G1 line keys on key matrix is touched.																																																								
41-44	P17-P14	OUT	Terminal not used.																																																								
45-51	SEG27-SEG21	OUT	<b>Segment data signal.</b> Connected to LCD. The relation between signals are as follows: <table border="0" style="width: 100%; border-collapse: collapse;"> <thead> <tr> <th style="text-align: left;">LSI signal (Pin No.)</th> <th style="text-align: left;">LCD (Pin No.)</th> <th style="text-align: left;">LSI signal (Pin No.)</th> <th style="text-align: left;">LCD (Pin No.)</th> </tr> </thead> <tbody> <tr> <td>SEG 27 (45) .....</td> <td>S16 (25)</td> <td>SEG 13 (59) .....</td> <td>S20 (12)</td> </tr> <tr> <td>SEG 26 (46) .....</td> <td>S15 (24)</td> <td>SEG 11 (61) .....</td> <td>S21 (11)</td> </tr> <tr> <td>SEG 25 (47) .....</td> <td>S14 (23)</td> <td>SEG 10 (62) .....</td> <td>S22 (10)</td> </tr> <tr> <td>SEG 24 (48) .....</td> <td>S13 (22)</td> <td>SEG 9 (63) .....</td> <td>S23 ( 9)</td> </tr> <tr> <td>SEG 23 (49) .....</td> <td>S12 (21)</td> <td>SEG 8 (64) .....</td> <td>S24 ( 8)</td> </tr> <tr> <td>SEG 22 (50) .....</td> <td>S11 (20)</td> <td>SEG 7 (65) .....</td> <td>S25 ( 7)</td> </tr> <tr> <td>SEG 21 (51) .....</td> <td>S10 (19)</td> <td>SEG 6 (66) .....</td> <td>S26 ( 6)</td> </tr> <tr> <td>SEG 19 (53) .....</td> <td>S9 (18)</td> <td>SEG 5 (67) .....</td> <td>S4 ( 5)</td> </tr> <tr> <td>SEG 18 (54) .....</td> <td>S8 (17)</td> <td>SEG 3 (69) .....</td> <td>S3 ( 4)</td> </tr> <tr> <td>SEG 17 (55) .....</td> <td>S7 (16)</td> <td>SEG 2 (70) .....</td> <td>S2 ( 3)</td> </tr> <tr> <td>SEG 16 (56) .....</td> <td>S6 (15)</td> <td>SEG 1 (71) .....</td> <td>S1 ( 2)</td> </tr> <tr> <td>SEG 15 (57) .....</td> <td>S5 (14)</td> <td>SEG 0 (72) .....</td> <td>S0 ( 1)</td> </tr> <tr> <td>SEG 14 (58) .....</td> <td>S19 (13)</td> <td></td> <td></td> </tr> </tbody> </table>	LSI signal (Pin No.)	LCD (Pin No.)	LSI signal (Pin No.)	LCD (Pin No.)	SEG 27 (45) .....	S16 (25)	SEG 13 (59) .....	S20 (12)	SEG 26 (46) .....	S15 (24)	SEG 11 (61) .....	S21 (11)	SEG 25 (47) .....	S14 (23)	SEG 10 (62) .....	S22 (10)	SEG 24 (48) .....	S13 (22)	SEG 9 (63) .....	S23 ( 9)	SEG 23 (49) .....	S12 (21)	SEG 8 (64) .....	S24 ( 8)	SEG 22 (50) .....	S11 (20)	SEG 7 (65) .....	S25 ( 7)	SEG 21 (51) .....	S10 (19)	SEG 6 (66) .....	S26 ( 6)	SEG 19 (53) .....	S9 (18)	SEG 5 (67) .....	S4 ( 5)	SEG 18 (54) .....	S8 (17)	SEG 3 (69) .....	S3 ( 4)	SEG 17 (55) .....	S7 (16)	SEG 2 (70) .....	S2 ( 3)	SEG 16 (56) .....	S6 (15)	SEG 1 (71) .....	S1 ( 2)	SEG 15 (57) .....	S5 (14)	SEG 0 (72) .....	S0 ( 1)	SEG 14 (58) .....	S19 (13)		
LSI signal (Pin No.)	LCD (Pin No.)	LSI signal (Pin No.)	LCD (Pin No.)																																																								
SEG 27 (45) .....	S16 (25)	SEG 13 (59) .....	S20 (12)																																																								
SEG 26 (46) .....	S15 (24)	SEG 11 (61) .....	S21 (11)																																																								
SEG 25 (47) .....	S14 (23)	SEG 10 (62) .....	S22 (10)																																																								
SEG 24 (48) .....	S13 (22)	SEG 9 (63) .....	S23 ( 9)																																																								
SEG 23 (49) .....	S12 (21)	SEG 8 (64) .....	S24 ( 8)																																																								
SEG 22 (50) .....	S11 (20)	SEG 7 (65) .....	S25 ( 7)																																																								
SEG 21 (51) .....	S10 (19)	SEG 6 (66) .....	S26 ( 6)																																																								
SEG 19 (53) .....	S9 (18)	SEG 5 (67) .....	S4 ( 5)																																																								
SEG 18 (54) .....	S8 (17)	SEG 3 (69) .....	S3 ( 4)																																																								
SEG 17 (55) .....	S7 (16)	SEG 2 (70) .....	S2 ( 3)																																																								
SEG 16 (56) .....	S6 (15)	SEG 1 (71) .....	S1 ( 2)																																																								
SEG 15 (57) .....	S5 (14)	SEG 0 (72) .....	S0 ( 1)																																																								
SEG 14 (58) .....	S19 (13)																																																										

Pin No.	Signal	I/O	Description
52	SEG20	OUT	Terminal not used.
53-59	SEG19-SEG13	OUT	<b>Segment data signal.</b> Signal similar to SEG27.
60	SEG12	OUT	Terminal not used.
61-67	SEG11-SEG5	OUT	<b>Segment data signal.</b> Signal similar to SEG27.
68	SEG4	OUT	Terminal not used.
69-72	SEG3-SEG0	OUT	<b>Segment data signal.</b> Signal similar to SEG27.
73/74	VCC/VREF	IN	Connected to GND.
75	AVSS	IN	Connected to VC.
76	COM3	OUT	<b>Common data signal: COM3.</b> Connected to LCD signal C3 (Pin No. 29)
77	COM2	OUT	<b>Common data signal: COM3.</b> Connected to LCD signal C2 (Pin No. 28)
78	COM1	OUT	<b>Common data signal: COM3.</b> Connected to LCD signal C1 (Pin No. 27)
79	COM0	OUT	<b>Common data signal: COM3.</b> Connected to LCD signal C0 (Pin No. 26)
80	VL3	IN	<b>Power source voltage input terminal.</b> Standard voltage for LCD.

## ABSOLUTE HUMIDITY SENSOR CIRCUIT

### (1) Structure of Absolute Humidity Sensor

The absolute humidity sensor includes two thermistors as shown in the illustration. One thermistor is housed in the closed vessel filled with dry air while another in the open vessel. Each sensor is provided with the protective cover made of metal mesh to be protected from the external airflow.

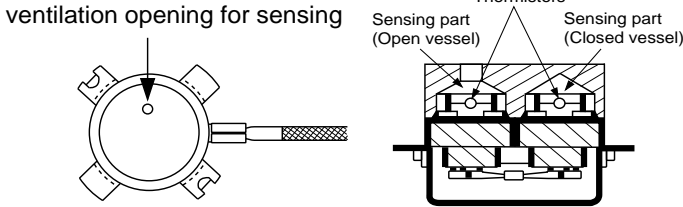

### (2) Operational Principle of Absolute Humidity Sensor

The figure below shows the basic structure of an absolute humidity sensor. A bridge circuit is formed by two thermistors and two resistors (R1 and R2).

The output of the bridge circuit is to be amplified by the operational amplifier.

Each thermistor is supplied with a current to keep it heated at about 150°C (302°F), the resultant heat is dissipated in the air and if the two thermistors are placed in different humidity conditions they show different degrees of heat conductivity leading to a potential difference between them causing an output voltage from the bridge circuit, the intensity of which is increased as the absolute humidity of the air increases. Since the output is very minute, it is amplified by the operational amplifier.

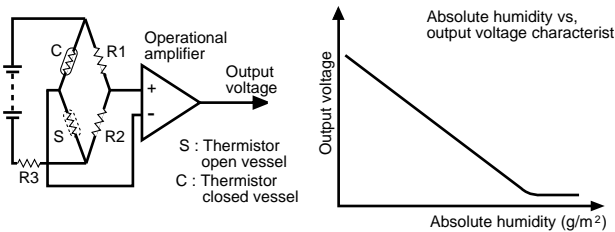

### (3) Detector Circuit of Absolute Humidity Sensor Circuit

This detector circuit is used to detect the output voltage of the absolute humidity circuit to allow the LSI to control sensor cooking of the unit. When the unit is set in the

sensor cooking mode, 16 seconds clearing cycle occurs than the detector circuit starts to function and the LSI observes the initial voltage available at its AN1 terminal. With this voltage given, the switches SW1 to SW5 in the LSI are turned on in such a way as to change the resistance values in parallel with R107 ~ R111 of IC2. Changing the resistance values results in that there is the same potential at both F-3 terminal of the absolute humidity sensor and AN0 terminal of the LSI. The voltage of AN1 terminal will indicate about -2.5V. This initial balancing is set up about 16 seconds after the unit is put in the Sensor Cooking mode. As the sensor cooking proceeds, the food is heated to generate moisture by which the resistance balance of the bridge circuit is deviated to increase the voltage available at AN1 terminal of the LSI.

Then the LSI observes that voltage at AN1 terminal and compares it with its initial value, and when the comparison rate reaches the preset value (fixed for each menu to be cooked), the LSI causes the unit to stop sensor cooking; thereafter, the unit goes in the next operation automatically.

When the LSI starts to detect the initial voltage at AN1 terminal 16 seconds after the unit has been put in the Sensor Cooking mode, if it is not possible to balance, of the bridge circuit due to disconnection of the absolute humidity sensor, ERROR will appear on the display and the cooking is stopped.

### 1) Absolute humidity sensor circuit

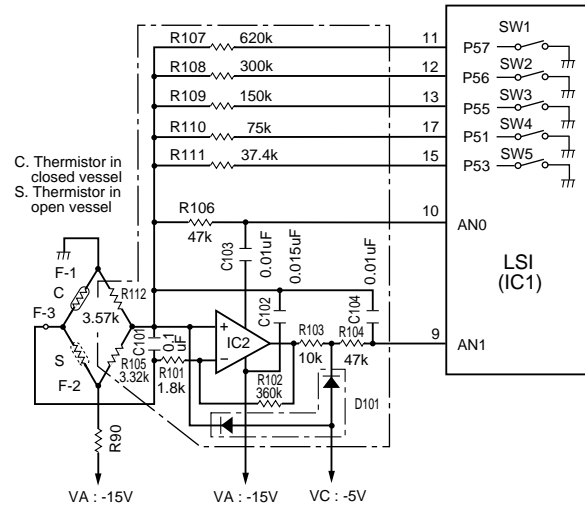

## TOUCH CONTROL PANEL SERVICING

### 1. Precautions for Handling Electronic Components

This unit uses CMOS LSI in the integral part of the circuits. When handling these parts, the following precautions should be strictly followed. CMOS LSI have extremely high impedance at its input and output terminals. For this reason, it is easily influenced by the surrounding high voltage power source, static electricity charge in clothes, etc. and sometimes it is not fully protected by the built-in protection circuit.

In order to protect CMOS LSI.

- 1) When storing and transporting, thoroughly wrap them in aluminium foil. Also wrap all PW boards containing them in aluminium foil.
- 2) When soldering, ground the technician as shown in the figure and use grounded soldering iron and work table.

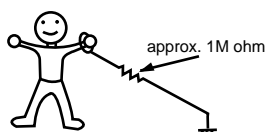

### 2. Shapes of Electronic Components

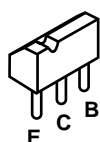

Transistor  
2SB1238

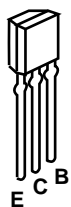

Transistor  
DTD143ES

### 3. Servicing of Touch Control Panel

We describe the procedures to permit servicing of the touch control panel of the microwave oven and the precautions you must take when doing so. To perform the servicing, power to the touch control panel is available either from the power line of the oven itself or from an external power source.

#### (1) Servicing the touch control panel with power supply of the oven:

##### CAUTION:

**THE HIGH VOLTAGE TRANSFORMER OF THE MICROWAVE OVEN IS STILL LIVE DURING SERVICING AND PRESENTS A HAZARD.**

Therefore, before checking the performance of the touch control panel,

- 1) Disconnect the power supply cord, and then remove outer case.
- 2) Open the door and block it open.
- 3) Discharge high voltage capacitor.
- 4) Disconnect the leads to the primary of the power transformer.
- 5) Ensure that these leads remain isolated from other components and oven chassis by using insulation tape.
- 6) After that procedure, re-connect the power supply cord. After checking the performance of the touch control panel,
  - 1) Disconnect the power supply cord.
  - 2) Open the door and block it open.
  - 3) Re-connect the leads to the primary of the power transformer.

4) Re-install the outer case (cabinet).

5) Re-connect the power supply cord after the outer case is installed.

6) Run the oven and check all functions.

- A. On some models, the power supply cord between the touch control panel and the oven itself is so short that the two can't be separated. For those models, check and repair all the controls (sensor-related ones included) of the touch control panel while keeping it connected to the oven.
- B. On some models, the power supply cord between the touch control panel and the oven proper is long enough that they may be separated from each other. For those models, it is possible to check and repair the controls of the touch control panel while keeping it apart from the oven proper; in this case you must short both ends of the door sensing switch (on PWB) of the touch control panel with a jumper, which activates an operational state that is equivalent to the oven door being closed. As for the sensor-related controls of the touch control panel, checking them is possible if dummy resistor(s) with resistance equal to that of the controls are used.

#### (2) Servicing the touch control panel with power supply from an external power source:

Disconnect the touch control panel completely from the oven proper, and short both ends of the door sensing switch (on PWB) of the touch control panel, which activates an operational state that is equivalent to the oven door being closed. Connect an external power source to the power input terminal of the touch control panel, then it is possible to check and repair the controls of the touch control panel it is also possible to check the sensor-related controls of the touch control panel by using the dummy resistor(s).

### 4. Servicing Tools

Tools required to service the touch control panel assembly.

- 1) Soldering iron: 30W  
(It is recommended to use a soldering iron with a grounding terminal.)
- 2) Oscilloscope: Single beam, frequency range: DC-10MHz type or more advanced model.
- 3) Others: Hand tools

### 5. Other Precautions

- 1) Before turning on the power source of the control unit, remove the aluminium foil applied for preventing static electricity.
- 2) Connect the connectors of the key unit to the control unit being sure that the lead wires are not twisted.
- 3) After aluminium foil is removed, be careful that abnormal voltage due to static electricity etc. is not applied to the input or output terminals.
- 4) Attach connectors, electrolytic capacitors, etc. to PWB, making sure that all connections are tight.
- 5) Be sure to use specified components where high precision is required.

## COMPONENT REPLACEMENT AND ADJUSTMENT PROCEDURE

### WARNING AGAINST HIGH VOLTAGE:

Microwave ovens contain circuitry capable of producing very high voltage and current, contact with following parts may result in severe, possibly fatal, electric shock.

(Example)

High Voltage Capacitor, Power Transformer, Magnetron, High Voltage Rectifier Assembly, High Voltage Harness etc..

**WARNING:** Avoid possible exposure to microwave energy. Please follow the instructions below before operating the oven.

1. Disconnect the power supply cord.
2. Make sure that a definite "click" can be heard when the microwave oven door is unlatched. (Hold the door in a closed position with one hand, then push the door open button with the other, this causes the latch leads to rise, it is then possible to hear a "click" as the door switches operate.)
3. Visually check the door and cavity face plate for damage (dents, cracks, signs of arcing etc.).
1. Door does not close firmly.
2. Door hinge, support or latch hook is damaged.
3. The door gasket or seal is damaged.
4. The door is bent or warped.
5. There are defective parts in the door interlock system.
6. There are defective parts in the microwave generating and transmission assembly.
7. There is visible damage to the oven.

Carry out any remedial work that is necessary before operating the oven.

Do not operate the oven if any of the following conditions exist;

Do not operate the oven:

1. Without the RF gasket (Magnetron).
2. If the wave guide or oven cavity are not intact.
3. If the door is not closed.
4. If the outer case (cabinet) is not fitted.

### WARNING FOR WIRING

**To prevent an electric shock, take the following precautions.**

1. Before wiring,
  - 1) Disconnect the power supply cord.
  - 2) Open the door block it open.
  - 3) Discharge the high voltage capacitor and wait for 60 seconds.
2. Don't let the wire leads touch to the following parts:
  - 1) High voltage parts:  
Magnetron, High voltage transformer, High voltage capacitor and High voltage rectifier assembly.
  - 2) Hot parts:  
Oven lamp, Magnetron, High voltage transformer and Oven cavity.
  - 3) Sharp edge:  
Bottom plate, Oven cavity, Waveguide flange, Chassis support and other metallic plate.
  - 4) Movable parts (to prevent a fault)  
Fan blade, Fan motor, Switch, Switch lever, Open button.
3. Do not catch the wire leads in the outer case cabinet.
4. Insert the positive lock connector until its pin is locked and make sure that the wire leads do not come off even if the wire leads are pulled.
5. To prevent an error function, connect the wire leads correctly, referring to the Pictorial Diagram.

Please refer to 'OVEN PARTS, CABINET PARTS, CONTROL PANAL PARTS, DOOR PARTS', when carrying out any of the following removal procedures:

### OUTER CASE REMOVAL

To remove the outer case, proceed as follows.

1. Disconnect the power supply cord.
2. Open the oven door and block it open.
3. Remove the two (2) screws from the lower portion of the rear cabinet using a T20H Torx type or GTXH20-100 screw driver.
4. Remove the remaining two (2) screws from rear and one (1) screw along the right side of outer case.
5. Slide the entire outer case back out about 1 inch (3 cm) to free it from retaining clips on the cavity face plate.
6. Lift entire outer case from the unit.

- CAUTION:** 1. DISCONNECT OVEN FROM POWER SUPPLY BEFORE REMOVING OUTER CASE.  
2. DISCHARGE THE HIGH VOLTAGE CAPACITOR BEFORE TOUCHING ANY OVEN COMPONENTS OR WIRING.

**NOTE:** When replacing the outer case, the 2 special Torx screws must be reinstalled in the same locations.

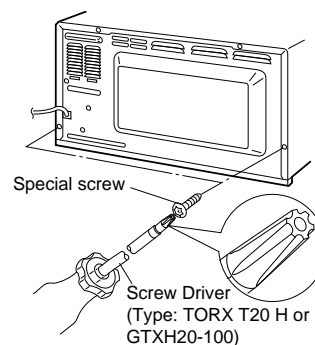

## POWER TRANSFORMER REMOVAL

1. Disconnect the power supply cord and remove outer case.
2. Open the oven door and block it open.
3. Discharge high voltage capacitor.
4. Disconnect wire leads from power transformer, magnetron and capacitor terminals.
5. Remove four (4) screws holding transformer to bottom right plate.
6. Remove transformer from bottom right plate.
7. Remove the one (1) terminal insulator and tube from filament lead (longer one) of power transformer.

### Re-install

1. Install the terminal insulator to receptacle of filament lead (longer one) of power transformer.
2. Rest transformer on the bottom right plate with its primary terminals toward the oven face plate.
3. Secure transformer with four screws to bottom right plate.
4. Re-connect wire leads (primary and high voltage) to power transformer and filament leads of transformer to magnetron and high voltage capacitor. Refer to "PICTORIAL DIAGRAM" on page 33.
5. Re-install outer case and check that oven is operating properly.

## TERMINAL INSULATOR REPLACEMENT

1. Disconnect the power supply cord, and then remove outer case.
2. Open the door and block it open.
3. Discharge high voltage capacitor.
4. Open covers of the terminal insulator by using small flat type screw driver.
5. Remove the receptacle from the terminal insulator.
6. Now, the terminal insulator is free.

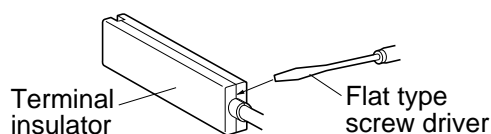

### Installation

1. Insert the receptacle into terminal insulator.
2. Close covers of the terminal insulator, as shown below.
3. Reconnect all leads removed from components during testing.
4. Reinstall the outer case (cabinet).
5. Reconnect the power supply cord after the outer case is installed.
6. Run the oven and check all functions.

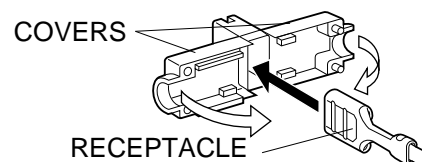

## HIGH VOLTAGE RECTIFIER AND HIGH VOLTAGE CAPACITOR REMOVAL

1. Disconnect the power supply cord and remove outer case.
2. Open the door and block it open.
3. Discharge high voltage capacitor.
4. Disconnect the high voltage wire B from the high voltage capacitor.
5. Disconnect the high voltage wire of high voltage rectifier assembly from the magnetron.
6. Remove one (1) screw holding capacitor holder to oven cavity rear plate.

7. Disconnect rectifier terminal from capacitor. High voltage rectifier assembly is now free.
8. Remove one (1) screw holding high voltage rectifier assembly to capacitor holder.
9. Remove capacitor holder. Capacitor is now free.

**CAUTION:** WHEN REPLACING HIGH VOLTAGE RECTIFIER AND HIGH VOLTAGE CAPACITOR, GROUND SIDE TERMINAL OF THE HIGH VOLTAGE RECTIFIER MUST BE SECURED FIRMLY WITH A GROUNDING SCREW.

## MAGNETRON REMOVAL

### Removal

1. Disconnect the power supply cord and remove outer case.
2. Open the door and block it open.
3. Discharge high voltage capacitor.
4. Disconnect wire leads from magnetron.
5. Remove the one (1) screw holding chassis support to magnetron.
6. Remove the chassis support from oven.
7. Carefully remove the four (4) screws holding magnetron to waveguide flange.
8. Lift up magnetron with care so that magnetron antenna is not hit by any metal object around antenna.
9. Now, the magnetron is free.

### Re-install

1. Re-install the magnetron to waveguide flange with the four (4) screws as shown in Figure C-1.
2. Insert the two (2) tabs of the chassis support to the oven cavity front plate and the back plate.
3. Re-install the chassis support to magnetron with the one (1) screw.

4. Reconnect the wire leads to the magnetron. Refer to "PICTORIAL DIAGRAM" on page 33.
5. Re-install outer case and check that the oven is operating properly.

CAUTION: WHEN REPLACING MAGNETRON, BE SURE THE R.F. GASKET IS IN PLACE AND MOUNTING SCREWS ARE TIGHTENED SECURELY

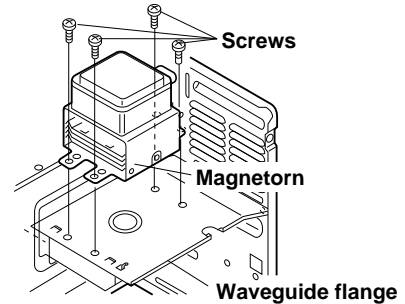

Figure C-1. Magnetron replacement

## OVEN LAMP AND LAMP SOCKET REMOVAL

1. Disconnect the power supply cord and remove outer case.
2. Open the door and block it open.
3. Discharge high voltage capacitor.
4. Bend the tab of the partition angle holding the lamp socket.
5. Lift up the oven lamp socket.
6. Pull the wire leads from the oven lamp socket by pushing the terminal hole of the oven lamp socket with the small flat type screw driver.
7. Now, the oven lamp socket is free.

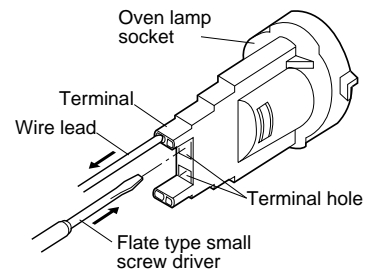

Figure C-2. Oven lamp socket

## POSITIVE LOCK® CONNECTOR (NO-CASE TYPE) REMOVAL

1. Disconnect the power supply cord, and remove outer case.
2. Open the door and block it open.
3. Discharge high voltage capacitor.
4. Push the lever of positive lock® connector.
5. Pull down on the positive lock® connector.

CAUTION: WHEN CONNECTING THE POSITIVE LOCK® CONNECTORS TO THE TERMINALS, INSTALL THE POSITIVE LOCK® SO THAT THE LEVER FACES YOU

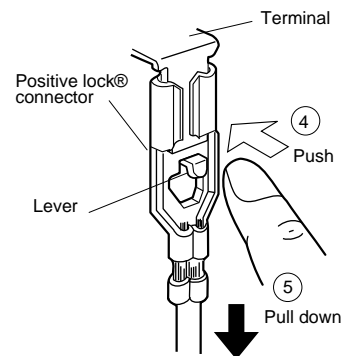

Figure C-3. Positive lock® connector

## CONTROL PANEL ASSEMBLY REMOVAL

1. Disconnect the power supply cord and remove outer case.
2. Open the door and block it open.
3. Discharge high voltage capacitor.
4. Disconnect wire leads from the door sensing switch and the oven cavity front flange.

5. Disconnect the wire leads from panel components.
6. Make one (1) tab of the oven cavity front plate straight holding the control panel assembly to the oven flange.
7. Slide the control panel assembly upward and remove it.
8. Now, individual components can be removed.

- NOTE: 1. Before attaching a new key unit, wipe off remaining adhesive on the control panel frame surfaces completely with a soft cloth soaked in alcohol.
2. When attaching the key unit to the control panel frame, adjust the upper edge and right edge of the key unit to the correct position of control panel frame.
3. Stick the key unit firmly to the control panel frame by rubbing with soft cloth not to scratch.

#### CPU UNIT AND POWER UNIT

NOTE: When soldering the CPU unit and the power unit, make sure both the CPU unit and power unit are parallel, as shown figure C-4.

Handle the CPU unit carefully so that the ribbon cable does not come off. Because the ribbon cable is glued on the LCD and the printed wiring board only by heated paste.

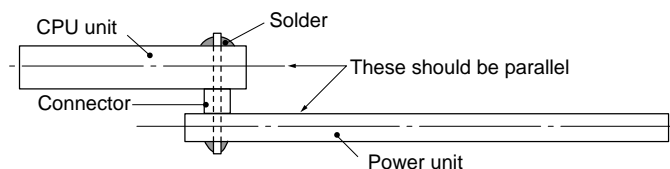

Figure C-4. Side view of CPU unit and Power unit

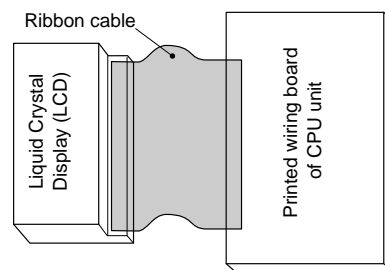

Figure C-5. CPU unit

## TURNTABLE MOTOR REMOVAL

1. Disconnect the power supply cord.
2. Remove turntable and turntable support from oven cavity.
3. Lay the oven on it's backside. Remove the turntable motor cover by snipping off the material in four corners.
4. Where the corners have been snipped off bend corner areas flat. No sharp edges must be evident after removal of the turntable motor cover.
5. Disconnect wire leads from turntable motor. (See "Positive lock connector removal")
6. Remove two (2) screws holding turntable motor to oven cavity.
7. Now the turntable motor is free.
8. After replacement use the one (1) screw to fit the turntable motor cover.

## COOLING FAN MOTOR REMOVAL

#### REMOVAL

1. Disconnect the power supply cord and remove outer case.
2. Open the door and block it open.
3. Discharge high voltage capacitor.
4. Disconnect the wire leads from the fan motor.
5. Remove the magnetron from the waveguide flange, referring to "MAGNETRON REMOVAL".
6. Release the snap of the main wire harness from the fan duct.
7. Remove one (1) screw holding the fan duct assembly to oven cavity.
8. Release the main wire harness from the hole of the fan duct.
9. Release the fan duct from the waveguide flange.
10. Release the fan duct assembly from the oven cavity.
11. Remove the fan blade from the fan motor shaft according to the following procedure.
12. Hold the edge of the rotor of the fan motor by using a pair of groove joint pliers.

#### CAUTION:

- \* **Make sure that any pieces do not enter the gap between the rotor and the stator of the fan motor because the rotor is easily shaven by pliers and metal pieces may be produced.**
  - \* **Do not touch the pliers to the coil of the fan motor because the coil may be cut or injured.**
  - \* **Do not disfigure the bracket by touching with the pliers.**
13. Remove the fan blade from the shaft of the fan motor by pulling and rotating the fan blade with your hand.

14. Now, the fan blade will be free.

#### CAUTION:

- \* **Do not reuse the removed fan blade because the hole (for shaft) may be larger than normal.**
15. Remove the two (2) screws holding the fan motor to the fan duct.
  16. Now, the fan motor is free.

#### INSTALLATION

1. Install the fan motor to the fan duct with the two (2) screws.
2. Install the fan blade to the fan motor shaft according to the following procedure.
3. Hold the center of the bracket which supports the shaft of the fan motor on the flat table.
4. Apply the screw lock tight into the hole (for shaft) of the fan blade.
5. Install the fan blade to the shaft of fan motor by pushing the fan blade with a small, light weight, ball peen hammer or rubber mallet.

#### CAUTION:

- \* **Do not hit the fan blade strongly when installed because the bracket may be disfigured.**
  - \* **Make sure that the fan blade rotates smooth after installation.**
  - \* **Make sure that the axis of the shaft is not slanted.**
6. Catch three holes of fan duct on three tabs of the waveguide flange.

7. Install the fan duct assembly to the oven cavity with the one (1) screw.
8. Insert the snap of the main wire harness to the hole of the fan duct and insert the main wire harness into the hole of the fan duct.

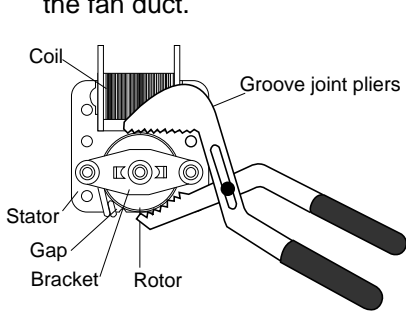

Rear View

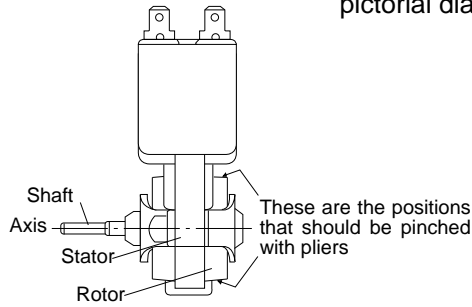

Side View

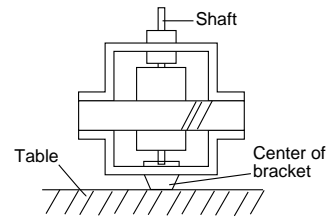

9. Install the magnetron and the chassis support to the oven cavity, referring to "Re-install of MAGNETRON REMOVAL".
10. Connect the wire leads to the fan motor, referring to the pictorial diagram.

## DOOR SENSING SWITCH/SECONDARY INTERLOCK SWITCH AND MONITOR SWITCH REMOVAL

1. Disconnect the power supply cord and remove outer case.
2. Open the door and block it open.
3. Discharge high voltage capacitor.
4. Disconnect wire leads from the switches.
5. Remove two (2) screws holding latch hook to oven flange.
6. Remove latch hook assembly from oven flange.
7. Push outward on the two (2) retaining tabs holding switch in place.
8. Switch is now free.  
At this time switch lever will be free, do not lose it.

### Re-install

1. Re-install each switch in its place. The secondary interlock/monitor switches are in the lower position and the door sensing switch is in the upper position.
2. Re-connect wire leads to each switch.  
Refer to pictorial diagram.
3. Secure latch hook (with two (2) mounting screws) to oven flange.
4. Make sure that the monitor switch is operating properly and check continuity of the monitor circuit. Refer to chapter "Test Procedure" and Adjustment procedure.

## DOOR SENSING SWITCH/SECONDARY INTERLOCK SWITCH AND MONITOR SWITCH ADJUSTMENT

1. Disconnect the power supply cord, and then remove outer case.
2. Open the door and block it open.
3. Discharge high voltage capacitor.

If the door sensing switch, secondary interlock switch and monitor switch do not operate properly due to a misadjustment, the following adjustment should be made.

4. Loosen the two (2) screws holding latch hook to the oven cavity front flange.
5. With door closed, adjust latch hook by moving it back and forth, and up and down. In and out play of the door allowed by the upper and lower position of the latch hook should be less than 0.5mm. The vertical position of the latch hook should be adjusted so that the door sensing switch and secondary interlock switch are activated with the door closed. The horizontal position of the latch hook should be adjusted so that the plunger of the monitor switch is pressed with the door closed.
6. Secure the screws with washers firmly.
7. Check the operation of all switches. If each switch has not activated with the door closed, loosen screw and adjust the latch hook position.

### After adjustment, check the following.

1. In and out play of door remains less than 0.5mm when in the latched position. First check upper position of latch

hook, pushing and pulling upper portion of door toward the oven face. Then check lower portion of the latch hook, pushing and pulling lower portion of the door toward the oven face. Both results (play in the door) should be less than 0.5mm.

2. The door sensing switch and secondary interlock switch interrupt the circuit before the door can be opened.
3. Monitor switch contacts close when door is opened.
4. Re-install outer case and check for microwave leakage around door with an approved microwave survey meter. (Refer to Microwave Measurement Procedure.)

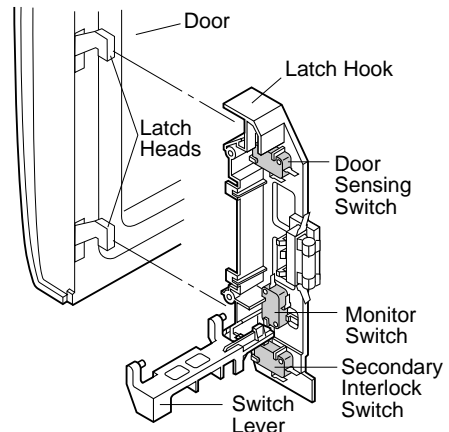

Figure C-6. Latch Switch Adjustments

## DOOR REPLACEMENT

### REMOVAL

1. Disconnect the power supply cord.
2. Push the open button and open the door slightly.
3. Insert a putty knife (thickness of about 0.5mm) into the gap between the choke cover and door frame as shown in Figure C-7 to free engaging parts.
4. Pry the principles of the lever and lift up the choke cover by inserting a putty knife as shown Figure C-7.
5. Release choke cover from door panel.
6. Now choke cover is free.
7. Release two (2) pins of door panel from two (2) holes of upper and lower oven hinges by lifting up.
8. Now, door panel with door frame is free from oven cavity.

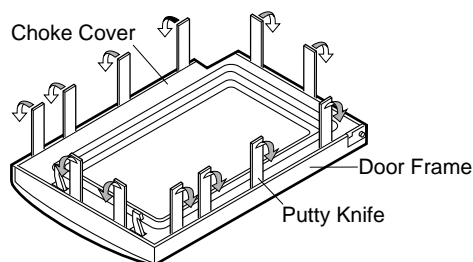
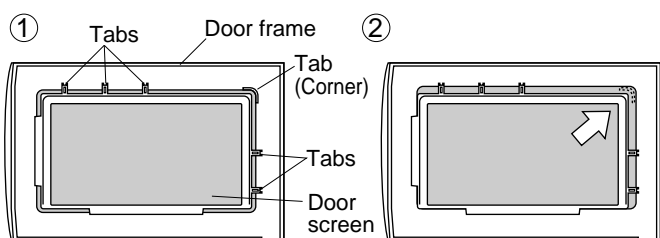

Figure C-7. Door Disassembly

9. Release door panel from nine (9) tabs of door frame by sliding door panel downward.
10. Now, door panel with sealer film is free.
11. Tear sealer film from door panel.
12. Now, door panel is free.
13. Slide latch head upward and remove it from door frame with releasing latch spring from door frame and latch head.
14. Now, latch head and latch spring are free.
15. Remove door screen from door frame as follows.
  - 1) Turn the door frame over. Refer to Figure ①.
  - 2) Push the upper right corner of the door screen by your finger from the front side of the door frame. And slide the door screen over the corner tab until the upper and right edges of the door screen touch the tabs of the door frame. Refer to Figure ②.



View; back side of door frame

- 3) Turn the door frame back. Refer to Figure ③.
- 4) Push the lower right corner of the door screen by your finger from the back side of the door frame. And slide the door screen clockwise. Refer to Figure ③.
- 5) Pull out the door screen toward the lower right corner of the door frame. Refer to Figure ④.

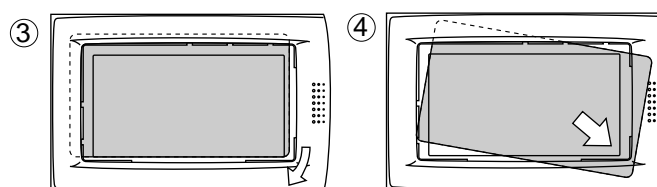

View; front side of door frame

16. Now, door screen is free.

### RE-INSTALL

1. Re-install door screen to door frame by reversing the procedure of item 15 of "REMOVAL".
2. Re-install the latch spring to the latch head. Re-install the latch spring to the door frame. Re-install latch head to door frame.
3. Re-install door panel to door frame by fitting nine (9) tabs of door frame to nine (9) holes of door panel.
4. Hold the door panel to the door frame by sliding the door panel upward.
5. Put sealer film on door panel. Refer to "Sealer Film" about how to handle new one.
6. Catch two (2) pins of door panel on two (2) hole of upper and lower oven hinges.
7. Re-install choke cover to door panel by pushing.

**Note: After any service to the door;**

- (A) Make sure that door sensing switch and secondary interlock switch are operating properly. (Refer to chapter "Test Procedures".)
- (B) An approved microwave survey meter should be used to assure compliance with proper microwave radiation emission limitation standards.

**After any service, make sure of the following :**

1. Door latch heads smoothly catch latch hook through latch holes and that latch head goes through center of latch hole.
2. Deviation of door alignment from horizontal line of cavity face plate is to be less than 1.0mm.
3. Door is positioned with its face pressed toward cavity face plate.
4. Check for microwave leakage around door with an approved microwave survey meter. (Refer to Microwave Measurement Procedure.)

**Note:** The door on a microwave oven is designed to act as an electronic seal preventing the leakage of microwave energy from oven cavity during cook cycle. This function does not require that door be airtight, moisture (condensation)-tight or light-tight. Therefore, occasional appearance of moisture, light or sensing of gentle warm air movement around oven door is not abnormal and do not of themselves indicate a leakage of microwave energy from oven cavity.

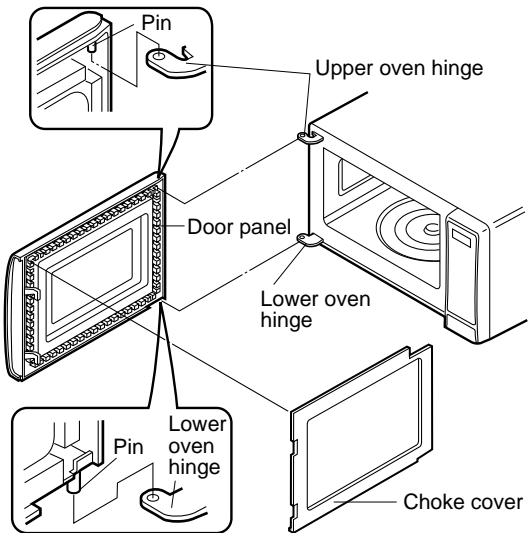
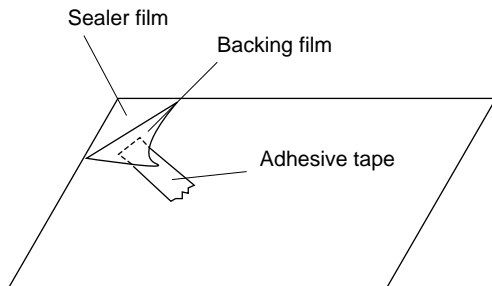

**Figure C-8. Door Replacement**

## **SEALER FILM**

### **Installation**

1. Put the adhesive tape on the backing film of the sealer film as shown in Fig. C-9.
2. Tear the backing film by pulling the adhesive tape.
3. Put the pasted side of the sealer film on the door panel



**Figure C-9. Sealer film**

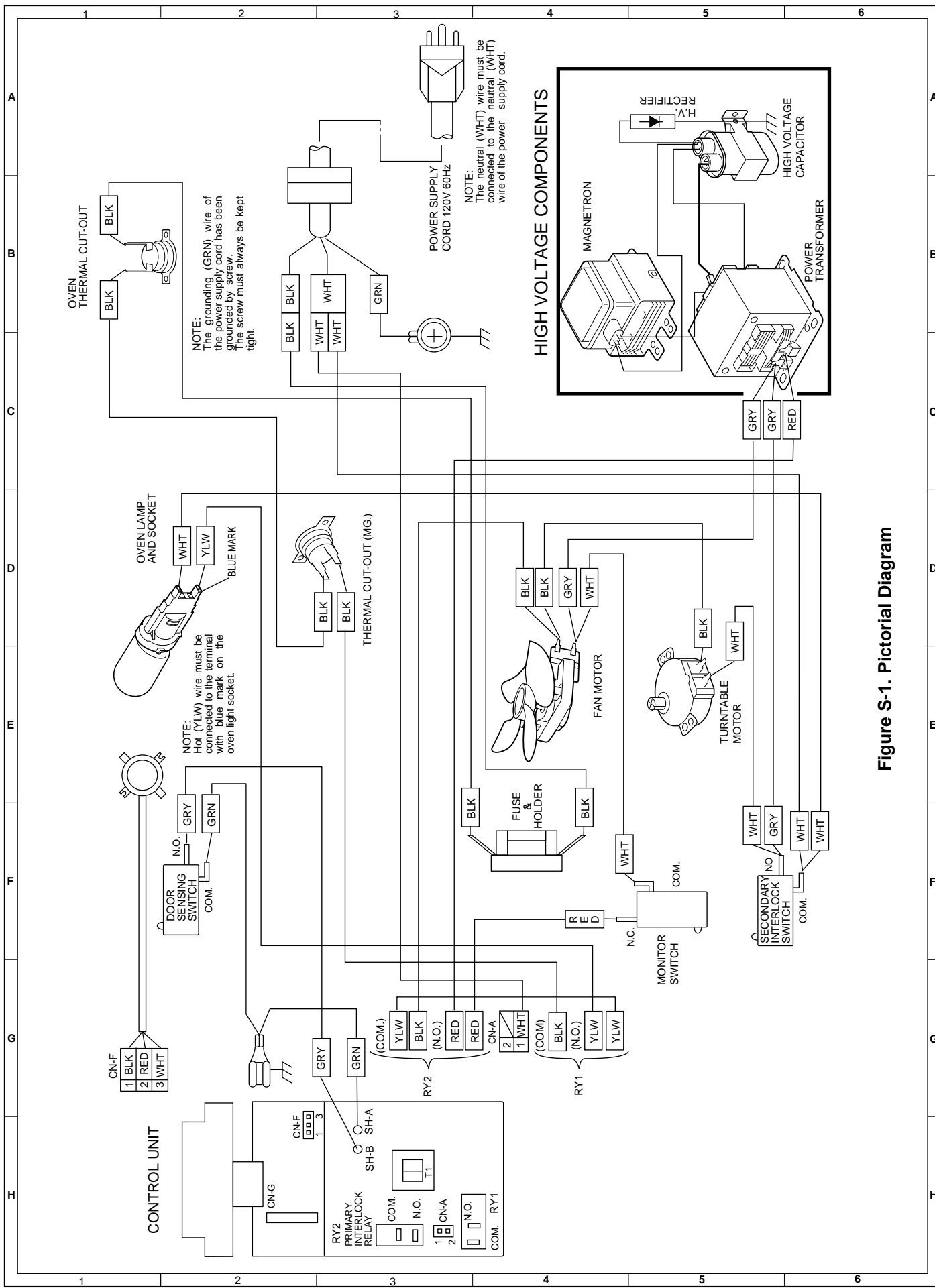
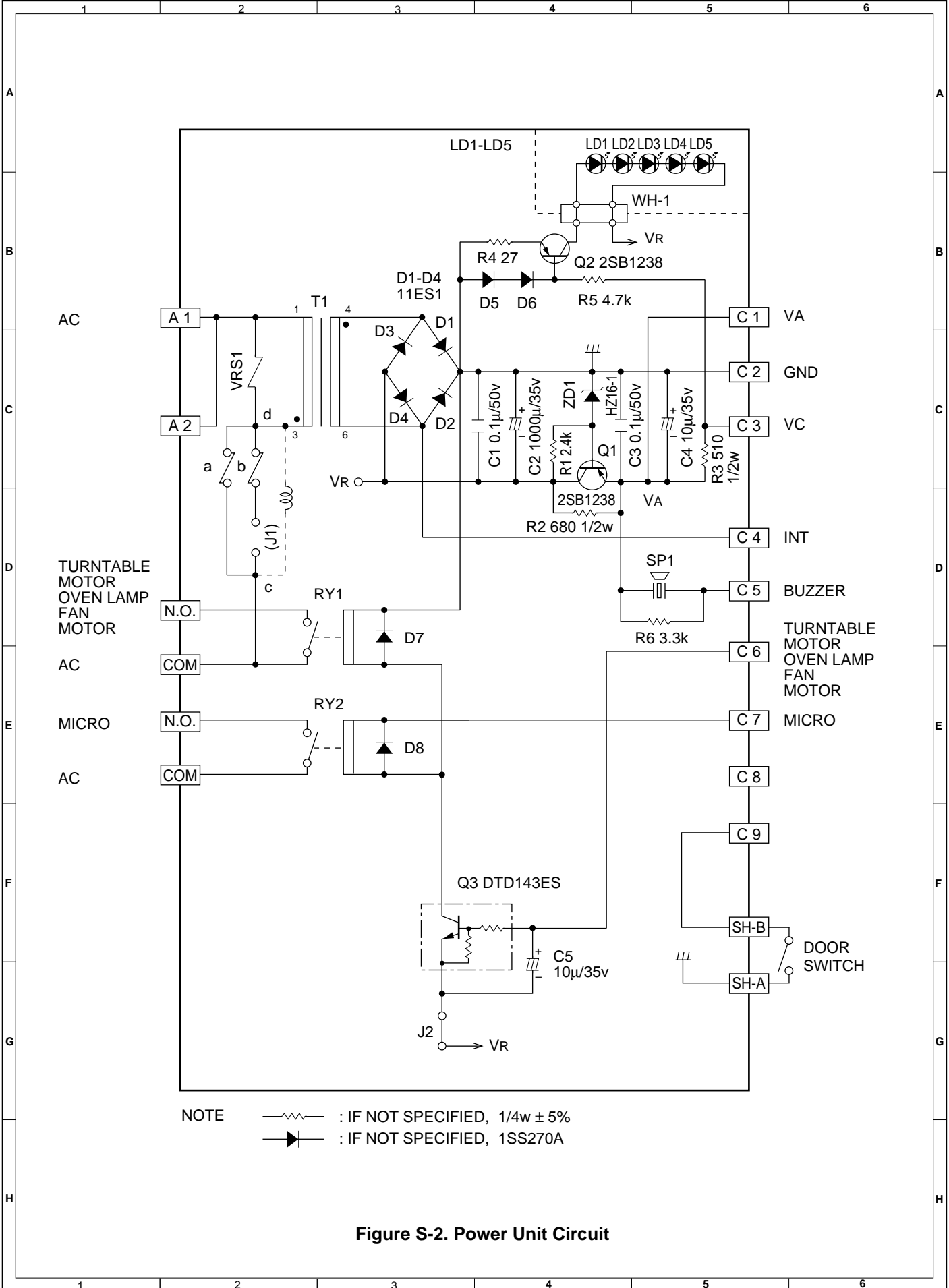
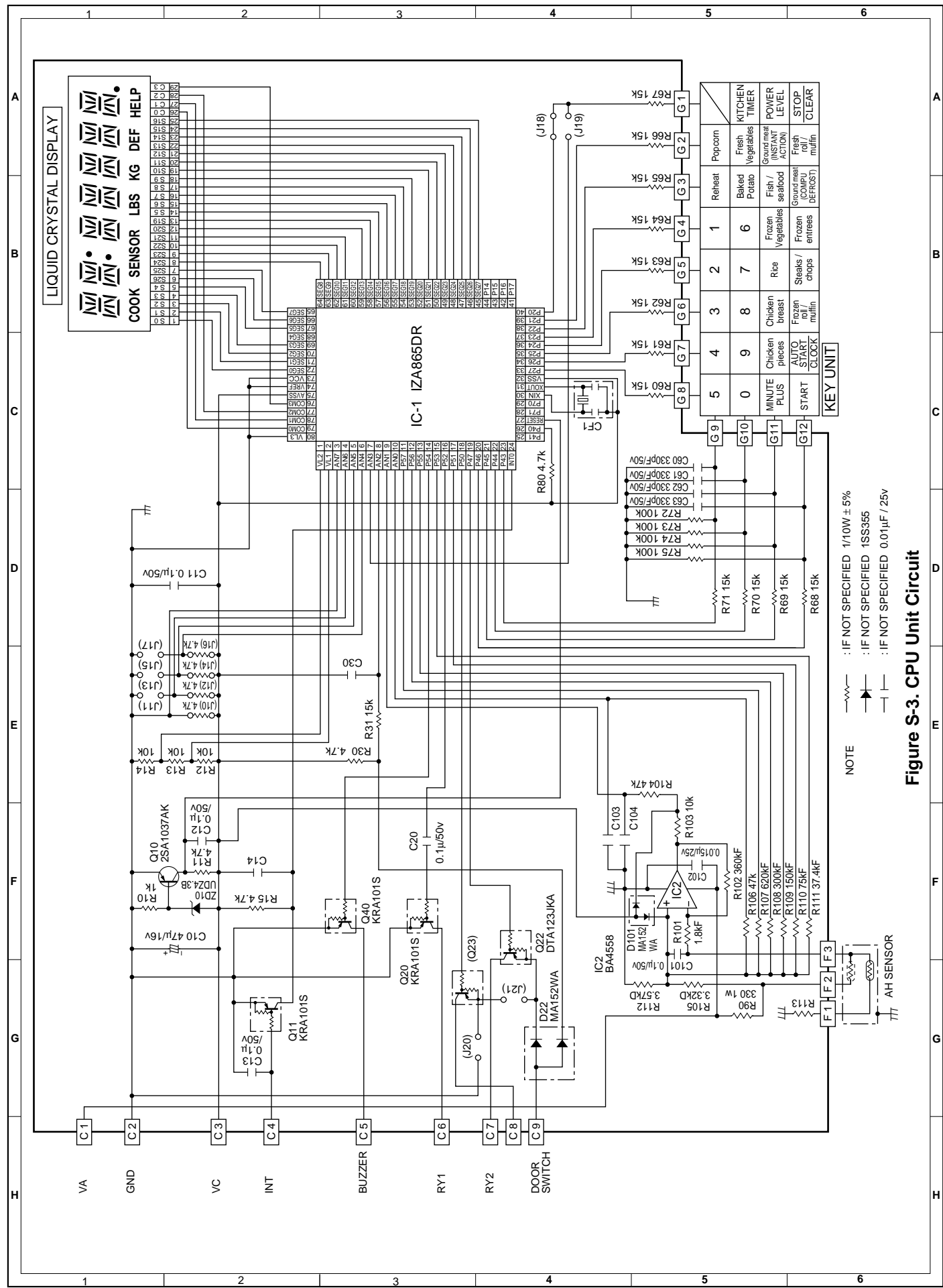

Figure S-1. Pictorial Diagram



NOTE    : IF NOT SPECIFIED, 1/4w ± 5%  
          : IF NOT SPECIFIED, 1SS270A

Figure S-2. Power Unit Circuit



NOTE  
 --- : IF NOT SPECIFIED 1/10W ± 5%  
 ▲ : IF NOT SPECIFIED 1SS355  
 — : IF NOT SPECIFIED 0.01µF / 25V

Figure S-3. CPU Unit Circuit



## PARTS LIST

**Note: The parts marked "Δ" may cause undue microwave exposure.  
The parts marked "\*" are used in voltage more than 250V.**

REF. NO.	PART NO.	DESCRIPTION	Q'TY	CODE
<b>ELECTRIC PARTS</b>				
1- 1	QSW-MA110WRE0	2nd interlock switch / door sensing switch	2	AK
1- 2	QFSHDA009WRE0	Fuse holder	1	AH
1- 3	FFS-BA012WRK0	Monitor fuse and monitor switch assembly	1	AH
1- 4	RTHM-A078WRE0	Thermal cut-out 125 deg.	1	AL
1- 5	FACCDAA077WRE0	Power supply cord	1	AU
* 1- 6	FH-DZA083WRK0	High voltage rectifier assembly	1	AQ
* 1- 7	RC-QZA236WRE0	High voltage capacitor	1	AU
Δ* 1- 8	RV-MZA267WRE0	Magnetron	1	BL
1- 9	RMOTEA355WRE0	Fan motor	1	AU
1-10	QSOCLA021WRE0	Oven lamp socket	1	AH
1-11	RLMPTA030WRE0	Oven lamp	1	AF
1-12	RMOTDA161WRE0	Turntable motor	1	AU
1-13	RTHM-A048WRE0	Thermal cut-out 170 deg.	1	AH
* 1-14	RTRN-A569WRE0	Power transformer	1	BP
1-15	FDTCTA176WRK0	AH sensor assembly	1	AV

### CABINET PARTS

2- 1	GCABUA631WRP0	Outer case cabinet [R-320BK]	1	BB
2- 1	GCABUA649WRP0	Outer case cabinet [R-320BW]	1	AZ
2- 1	GCABUA671WRT0	Outer case cabinet [R-320BB]	1	AV
2- 2	GDAI-A261WRW0	Bottom left plate	1	AP
2- 3	GDAI-A286WRW0	Bottom right plate	1	AN
2- 4	GLEGPA019WRE0	Foot	2	AD
2- 5	GLEGPA067WRF0	Leg	1	AE

### CONTROL PANEL PARTS

3- 1	CPWBFA776WRK0	Power unit	1	BD
3- 1A	QCNCMA446DRE0	2-pin connector (CN-A)	1	AC
3- 1B	QCNCMA422DRE0	9-pin connector (CN-C)	1	AF
3- 1C	FW-VZA196DRE0	2P wire harness (WH-1)	1	AD
3- 1D	FW-VZA195DRE0	Switch harness A (SH-A)	1	AD
3- 1E	FW-VZA197DRE0	Switch harness B (SH-B)	1	AD
3- 1F	LHLD-A171WRF0	LED holder	1	AE
C1	RC-KZA087DRE0	Capacitor 0.1 uF 50V	1	AB
C2	VCEAB31VW108M	Capacitor 1000 uF 35V	1	AD
C3	RC-KZA087DRE0	Capacitor 0.1 uF 50V	1	AB
C4-5	VCEAB31VW106M	Capacitor 10 uF 35V	2	AB
D1-4	VHD11ES1///-1	Diode (11ES1)	4	AB
D5-8	VHD1SS270A/-1	Diode (1SS270ATA)	4	AA
LD1-5	VHPSLZ381A9-3	Light emitting diode	5	AC
Q1-2	VS2SB1238// -3	Transistor (2SB1238)	2	AA
Q3	VSDTD143ES/-3	Transistor (DTD143ES)	1	AC
R1	VRD-B12EF242J	Resistor 2.4k ohm 1/4W	1	AA
R2	VRD-B12HF681J	Resistor 680 ohm 1/2W	1	AA
R3	VRD-B12HF511J	Resistor 510 ohm 1/2W	1	AB
R4	VRD-B12EF270J	Resistor 27 ohm 1/4W	1	AA
R5	VRD-B12EF472J	Resistor 4.7k ohm 1/4W	1	AA
R6	VRD-B12EF332J	Resistor 3.3k ohm 1/4W	1	AA
RY1	RRLY-A076DRE0	Relay (OMIF-S-124LM)	1	AK
RY2	RRLY-A081DRE0	Relay (VRB24)	1	AL
SP1	RALM-A014DRE0	Buzzer (PKM22EPT)	1	AG
T1	RTRNPA111DRE0	Transformer	1	AP
VRS1	RH-VZA032DRE0	Varistor (10G471K)	1	AE
ZD1	VHEHZ161///-1	Zener diode (HZ16-1)	1	AA
3- 2	DPWFBF753WRK0	CPU unit	1	BD
3- 3	FPNLCB358WRK0	Control panel frame with key unit [R-320BK]	1	BB
3- 3	FPNLCB359WRK0	Control panel frame with key unit [R-320BW]	1	BB
3- 3	FPNLCB372WRK0	Control panel frame with key unit [R-320BB]	1	BD
3- 3-1	FUNTKA852WRE0	Key unit [R-320BK]	1	AX
3- 3-1	FUNTKA853WRE0	Key unit [R-320BW]	1	AX
3- 3-1	FUNTKA867WRE0	Key unit [R-320BB]	1	AY
3- 3-2	JBTN-B088WRF0	Open button [R-320BK]	1	AF
3- 3-2	JBTN-B089WRF0	Open button [R-320BW]	1	AF
3- 3-2	JBTN-B090WRF0	Open button [R-320BB]	1	AF
3- 3-3	MSPRCA050WRE0	Open button spring	1	AB
3- 4	PSHEPA588WRE0	LED sheet	1	AE
3- 5	XEPSD30P08XS0	Screw; 3mm x 8mm	4	AA

REF. NO.	PART NO.	DESCRIPTION	Q'TY	CODE
<b>OVEN PARTS</b>				
4- 1	PCUSUA376WRP0	Cushion	1	AG
4- 2	PPACGA084WRF0	TTM packing	1	AF
4- 3	PHOK-A106WRF0	Latch hook	1	AL
4- 4	LBNDKA099WRW0	Capacitor holder	1	AD
4- 5	NFANJA029WRE0	Fan blade	1	AL
4- 6	PDUC-A652WRP0	Fan duct	1	AU
4- 7	*****	Oven cavity (Not a replaceable part)	1	--
4- 8	LANGFA175WRP0	Chassis support	1	AX
4- 9	LANGQA452WRP0	Partition angle	1	AK
4-10	LANGQA492WRP0	MG thermo angle	1	AV
4-11	MLEVPA226WRF0	Switch lever	1	AF
4-12	NCPL-A045WRF0	Coupling	1	AH
4-13	PCUSGA399WRE0	Cushion	1	AF
4-14	PCOVPA275WRE0	Waveguide cover	1	AR
4-15	PCUSGA339WRP0	Cushion	1	AG
4-16	PCUSUA212WRP0	Cushion	1	AB
4-17	LANGTA338WRP0	Sensor mounting angle	1	AP
4-18	GCOVHA385WRF0	Choke cover	1	AG
4-19	PCUSGA385WRP0	Cushion	1	AH
4-20	PCUSUA192WRP0	Cushion	1	AD
4-21	PCUSUA329WRP0	Cushion	1	AC
4-22	PGIDHA058WRP0	MG air guide	1	AE
4-23	PCUSUA126WRP0	Cushion	1	AC

<b>DOOR PARTS</b>				
5- 1	FDORFA318WRT0	Door panel	1	BE
5- 2	PSHEPA382WRE0	Sealer film	1	AH
5- 3	GWAKPA547WRR0	Door frame [R-320BK]	1	AZ
5- 3	GWAKPA549WRR0	Door frame [R-320BW]	1	AZ
5- 3	GWAKPA561WRR0	Door frame [R-320BB]	1	AZ
5- 4	HPNL-A684WRR0	Door screen [R-320BK]	1	AT
5- 4	HPNL-A690WRR0	Door screen [R-320BW]	1	AT
5- 4	HPNL-A684WRR0	Door screen [R-320BB]	1	AT
5- 5	LSTPPA139WRF0	Latch head	1	AF
5- 6	MSPRTA187WRE0	Latch spring	1	AC
5- 7	XCPD40P08000	Screw : 4mm x 8mm	1	AA
5- 8	XCPD40P08WN2	Screw : 4mm x 8mm	1	AC

<b>MISCELLANEOUS</b>				
6- 1	FROLPA079WRK0	Turntable support	1	AQ
6- 2	NTNT-A079WRE0	Turntable tray	1	AR
6- 3	FW-VZB678WRE0	Main wire harness	1	AW
6- 4	QW-QZA150WRE0	High voltage wire B	1	AF
6- 5	PZET-A012WRE0	Terminal insulator	1	AB
6- 6	TCAUAA166WRR0	DHHS caution label	1	AC
6- 7	TCAUAA200WRR0	Monitor caution label	1	AB
6- 8	TINSEA741WRR0	Instruction book	1	AE
6- 9	TCAUAA240WRR0	Screw caution	1	AC
6-10	TLABMA559WRR0	Menu label	1	AD

<b>SCREWS,NUTS AND WASHERS</b>				
7- 1	XFPSD40P08K00	Screw : 4mm x 8mm	6	AA
7- 2	XHPD30P06000	Screw : 3mm x 6mm	4	AA
7- 3	XHTSD40P08RV0	Screw : 4mm x 8mm	3	AA
7- 4	XFTSD40P08000	Screw : 4mm x 8mm	4	AA
7- 5	XOTSD40P12RV0	Screw : 4mm x 12mm	7	AA
7- 6	XOTSD40P12000	Screw : 4mm x 12mm	13	AA
7- 7	XOTSF40P08000	Screw : 4mm x 8mm [R-320BB]	1	AA
7- 7	XOTSF40P08000	Screw : 4mm x 8mm [R-320BK]	1	AA
7- 7	XOTSE40P08000	Screw : 4mm x 8mm [R-320BW]	1	AA
7- 8	LX-CZA070WRE0	Special screw (Torx tamper proof screw)	2	AC

### HOW TO ORDER REPLACEMENT PARTS

To have your order filled promptly and correctly, please furnish the following information.

1. MODEL NUMBER      2. REF. NO.      3. PART NO.      4. DESCRIPTION

Order Parts from the authorized SHARP parts Distributor for your area.

Defective parts requiring return should be returned as indicated in the Service Policy.

### OVEN AND CABINET PARTS

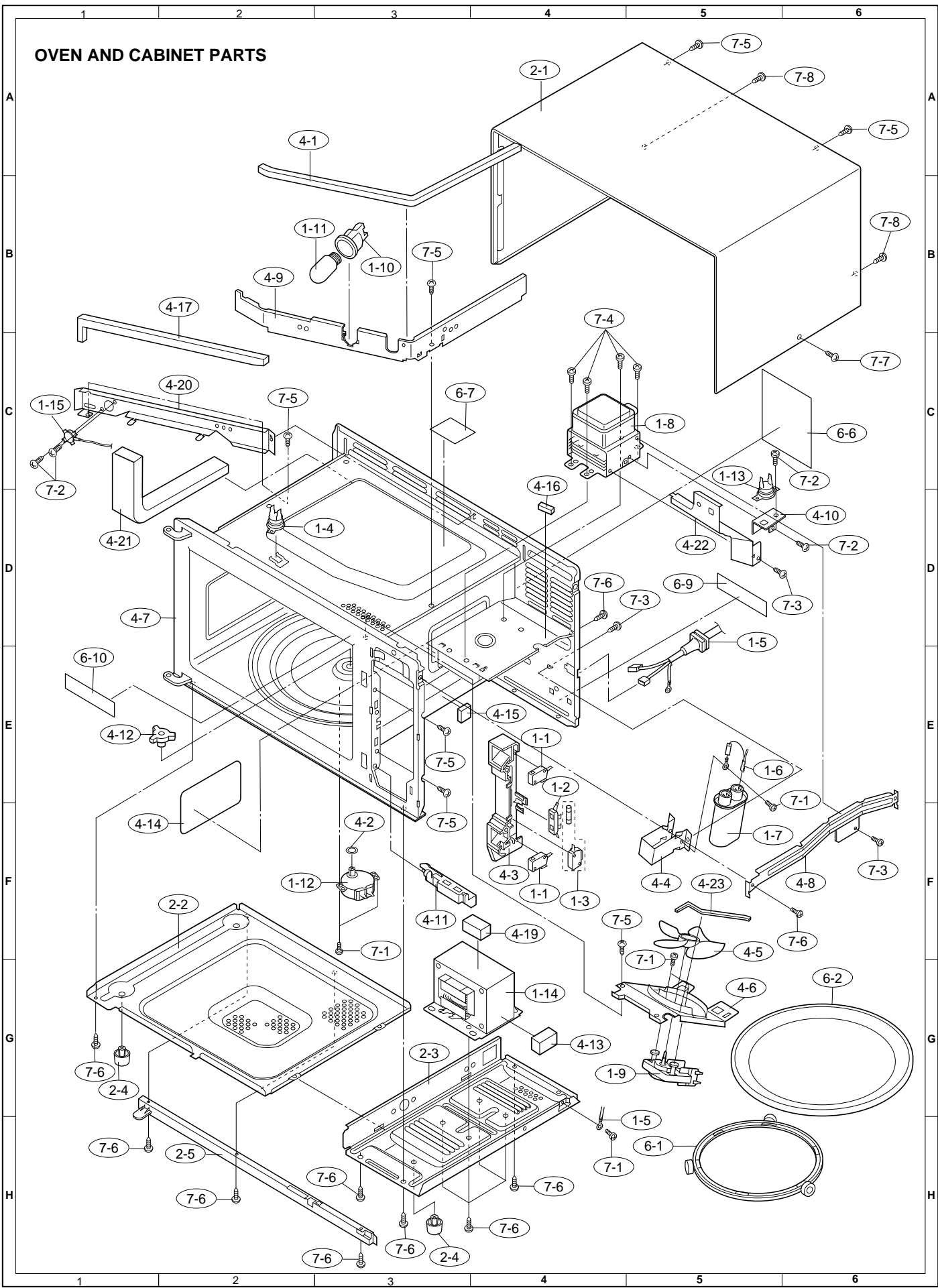

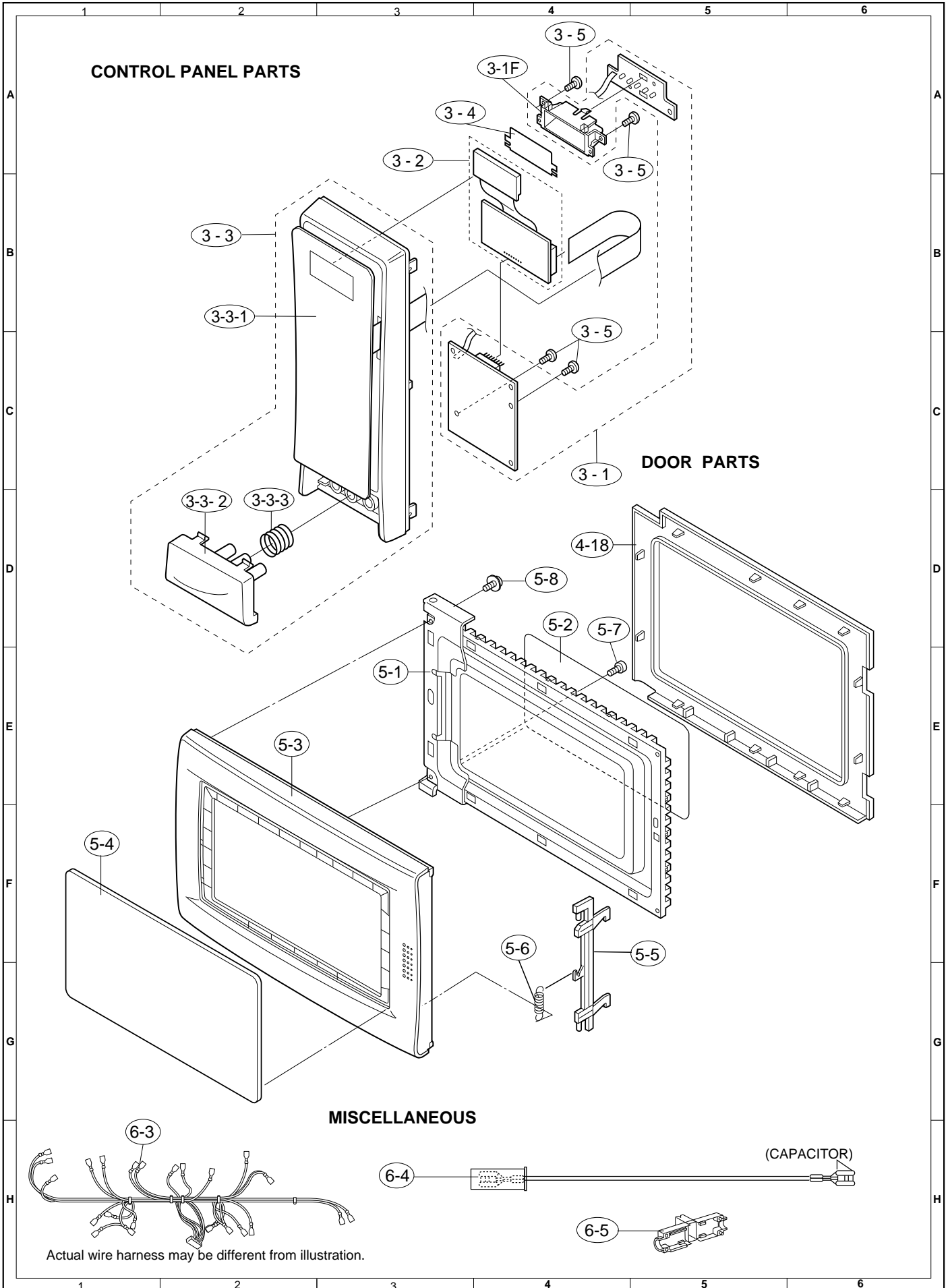

**PACKING AND ACCESSORIES**

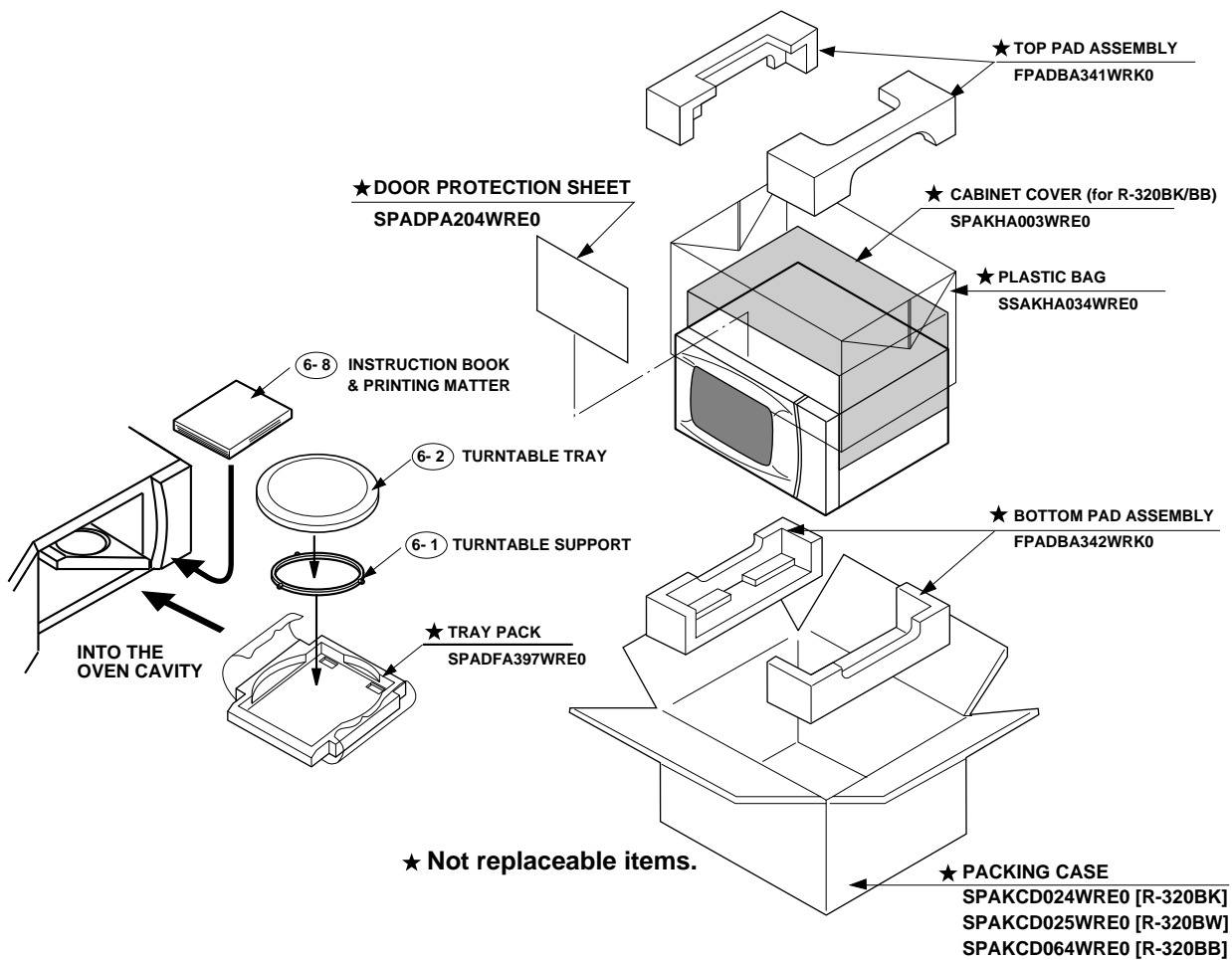

# SHARP

COPYRIGHT © 1997 BY SHARP CORPORATION

ALL RIGHTS RESERVED.

No part of this publication may be reproduced, stored in retrieval systems, or transmitted in any form or by any means, electronic, mechanical, photocopying, recording, or otherwise, without prior written permission of the publisher.