

This Owner's Manual is provided and hosted by [Appliance Factory Parts](#).

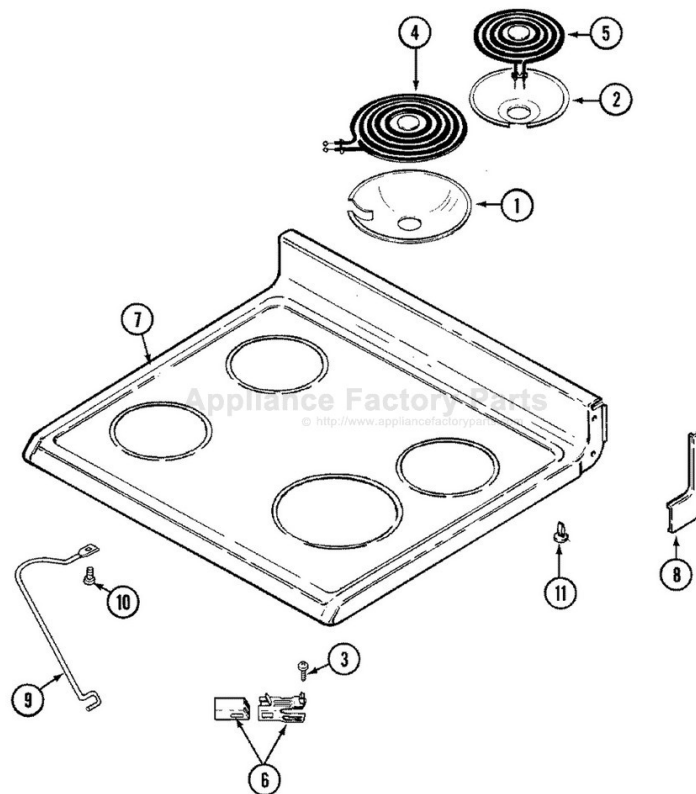

# MAYTAG MER1140AAW Owner's Manual

[Shop genuine replacement parts for MAYTAG  
MER1140AAW](#)



[Find Your MAYTAG Electric Range Parts - Select From 1309 Models](#)

----- Manual continues below -----



# Owner's Guide

for

## 30-inch Electric Ranges

### TABLE OF CONTENTS

<b>IMPORTANT SAFETY INSTRUCTIONS</b> .....	1-4	Preheating .....	10
<b>CLOCK AND TIMER</b> , if equipped .....	5	Use of aluminum foil .....	10
<b>SURFACE COOKING</b> .....	6	Oven racks .....	11
Control knobs .....	6	Common baking problems chart .....	12
Cooking tips .....	6	Baking tips .....	13
Cookware .....	6	Roasting tips .....	13
Heat setting guide .....	6	Broiling tips and chart .....	14
<b>SMOOTHTOP COOKTOP</b> , if equipped .....	7-8	<b>CARE AND CLEANING CHART</b> .....	15-16
<b>COIL ELEMENT COOKTOP</b> , if equipped .....	9	<b>MAINTENANCE</b> .....	17-18
<b>OVEN USE</b> .....	10-19	Cooktop .....	17
Oven light, if equipped .....	10	Oven light, if equipped .....	17
Oven vent .....	10	Oven door .....	17
Oven characteristics .....	10	Continuous clean oven, if equipped .....	18
Oven controls .....	10	Storage drawer, if equipped .....	18
Oven indicator light .....	10	Leveling legs .....	18
How to set oven to bake .....	10	<b>SERVICE INFORMATION</b> .....	19
		Before you call for service .....	19
		How to obtain service .....	19

**INSTALLER** Please leave this manual with this appliance.

Be sure appliance has been properly installed.

**CONSUMER** To save you time, energy and money, read and keep this manual for future reference.

The model and serial numbers are found on the rating plate located on the range front frame. Open the storage drawer or oven door to see the rating plate. Use these numbers when requesting service.

Model Number: \_\_\_\_\_

Serial Number: \_\_\_\_\_

Date of Purchase: \_\_\_\_\_

Please keep your sales receipt and/or your cancelled check as proof of purchase should warranty service be needed. Store these documents with this booklet.

*OK to Print  
mstrach  
8-19-96*

*1ST PROOF  
8-15-96*

**8113P127-60**  
(08-96-02)

# IMPORTANT SAFETY INSTRUCTIONS

Read all instructions before using this appliance.

## ABOUT YOUR NEW ELECTRIC RANGE

Congratulations on your choice of this electric range. As you use your new range, we know you will appreciate the many features that provide excellent performance, ease of cleaning, convenience and dependability.

New features have dramatically changed today's cooking appliances and the way we cook. It is therefore very important to understand how your new electric range operates BEFORE you use it for the first time.

In this Owner's Guide, you will find a wealth of information regarding all aspects of your appliance. By carefully following the instructions, you will be able to fully enjoy and properly maintain your new range. NOTE: Your appliance may not be equipped with some of the features referred to in this manual.

Should you have any questions about using your new electric appliance, please write to us at this address:

Customer Assistance  
c/o Maytag Customer Service  
P.O. Box 2370  
Cleveland, TN 37320-2370

Be sure to include the model and serial numbers of your appliance. For your convenience, we have provided space on the front cover to record this information.

In our continuing effort to improve the quality and customer satisfaction of our cooking products, we may find it necessary to make changes to our line of appliances without revising the Owner's Guide.

## IMPORTANT INSTRUCTIONS

Instructions on the following pages are based on safety considerations and must be strictly followed to eliminate the potential risks of fire, electric shock, or personal injury.

	 <b>WARNING</b>
	<ul style="list-style-type: none"> <li>• ALL RANGES CAN TIP</li> <li>• INJURY TO PERSONS COULD RESULT</li> <li>• INSTALL ANTI-TIP DEVICE PACKED WITH RANGE</li> <li>• SEE INSTALLATION INSTRUCTIONS</li> </ul>

**WARNING:** To reduce the risk of tipping of the appliance from abnormal usage or by excessive loading of the oven door, the appliance must be secured by a properly installed anti-tip device.

If the range is moved from the wall for cleaning, be sure the anti-tip device is engaged when the range is replaced. Remove storage drawer, if equipped, and look underneath range to verify that one of the rear leveling legs is properly engaged in the bracket slot. The anti-tip device secures the rear leveling leg to the floor when properly engaged.



50% POST-CONSUMER FIBER  
100% DE-INKED NEWSPAPERS, MAGAZINES & CATALOGS

# IMPORTANT SAFETY INSTRUCTIONS

2

Be sure appliance is properly installed and grounded by a qualified technician.

Locate and mark circuit breaker or fuse. Never replace a blown fuse or reset a circuit breaker until you know what caused the problem. Always replace a blown fuse with one of the correct amperage, do not use a substitute.

To ensure proper operation and avoid possible injury or damage to unit do not attempt to adjust, repair, service, or replace any part of your appliance unless it is specifically recommended in this book. All other servicing should be referred to a qualified installer or servicer. Always disconnect power to unit **before** any servicing by tripping circuit breaker to the OFF position or removing the fuse.

## TO PREVENT FIRE OR SMOKE DAMAGE

Be sure all packing materials are removed from the appliance before operating it.

Do not store or use gasoline or other flammable materials, vapors and liquids in the oven, near surface units or in the vicinity of this or any other appliance. The fumes can create a fire hazard or explosion.

If appliance is installed near a window, proper precautions should be taken to prevent curtains from blowing over surface elements.

Do not leave any items on the cooktop. The hot air from the vent may ignite flammable items and may increase pressure in closed containers which may cause them to burst.

Many aerosol-type spray cans are **EXPLOSIVE** when exposed to heat and may be highly flammable. Avoid their use or storage near an appliance.

Many plastics are vulnerable to heat. Keep plastics away from parts of the appliance that may become warm or hot. Do not leave plastic items on the cooktop as they may melt or soften if left too close to the vent or surface element.

To eliminate the hazard of reaching over hot surface elements, cabinet storage should not be provided directly above a unit. If such storage is provided, it should be limited to items which are used infrequently and which are safely stored in an area subjected to heat from an appliance. Temperatures may be unsafe for some items, such as volatile liquids, cleaners or aerosol sprays.

## IN CASE OF FIRE

Turn off appliance and ventilating hood to avoid spreading the flame. Extinguish flame then turn on hood to remove smoke and odor.

Use dry chemical or foam-type extinguisher or baking soda to smother fire or flame. Never use water on a grease fire.

If fire is in the oven or broiler pan, smother by closing oven door.

If fire is in a pan on the surface element, cover pan. Never attempt to pick up or move a flaming pan.

## CHILD SAFETY

Do not leave children alone or unsupervised near the appliance when it is in use or is still hot. Children should never be allowed to sit or stand on any part of the appliance.

Children must be taught that the appliance and utensils in or on it can be hot. Let hot utensils cool in a safe place, out of reach of small children. Children should be taught that an appliance is not a toy. Children should not be allowed to play with controls or other parts of the unit.

**CAUTION:** Do not store items of interest to children in cabinets above an appliance or on the backguard of a range. Children climbing on the appliance or on the appliance door to reach items could be seriously injured.

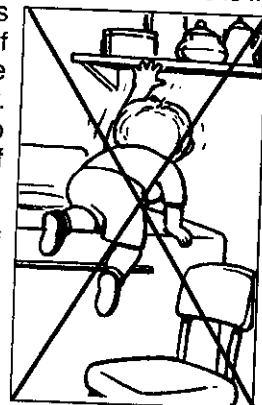

## ABOUT YOUR APPLIANCE

To prevent injury or damage to the appliance, do not use appliance as a space heater to heat or warm a room. Also, do not use the cooktop or oven as a storage area for food or cooking utensils.



The oven vent is located at the rear of the cooktop or at the right rear element. Keep oven vent duct unobstructed. Blockage of the vent prevents proper oven air circulation and will affect oven performance. Avoid touching vent area while oven is on and for several minutes after oven is turned off. Some parts of the vent and surrounding areas may become hot enough to cause burns.

# IMPORTANT SAFETY INSTRUCTIONS

Do not touch surface or oven elements, areas near elements or interior surface of oven. Heating elements may be hot even though they are dark in color. Areas near surface elements and interior surfaces of an oven may become hot enough to cause burns. During and after use, do not touch, or let clothing or other flammable materials contact heating elements, areas near elements, or interior surfaces of oven until they have had sufficient time to cool.

Other surfaces of the appliance may become hot enough to cause burns – among these surfaces are the cooktop, surfaces facing the cooktop, oven vent opening and surfaces near the vent opening, oven door, and oven window.

Do not allow aluminum foil, meat probes or any other metal object, other than a utensil on a surface element, to contact heating elements.

Do not touch a hot oven light bulb with a damp cloth as the bulb could break. If bulb breaks, disconnect power to the appliance to avoid electrical shock then remove bulb.

**CAUTION:** Do not use an appliance as a step stool to cabinets above. Misuse of appliance doors or drawers, such as stepping, leaning or sitting on the door or drawer, may result in possible tipping of the appliance, breakage of door, and serious injuries.

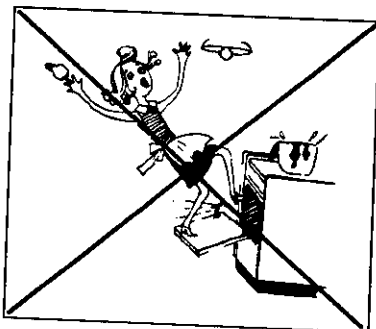

## COOKING SAFETY

Always turn off surface element or the oven when cooking is completed.

It is normal for some parts of the cooktop, especially areas surrounding the surface elements, to become warm or hot during surface cooking operations. Therefore, do not touch the cooktop until it has had sufficient time to cool. If necessary, use dry pot holders to protect hands.

Do not cook on a broken ceramic glass cooktop. If cooktop should break, cleaning solutions and spillovers may penetrate the broken cooktop and create a risk of electric shock. Contact a qualified technician immediately.

Make sure drip bowls are in place. Absence of these bowls during cooking may subject wiring or components underneath to damage.

Always place a pan on a surface element before turning it on. Be sure you know which knob controls which surface element. Make sure the correct element is turned on. Begin

cooking on a higher heat setting then reduce to a lower setting to continue cooking. For smoothtops: To prevent boilovers, reduce to the desired heat setting just as the food begins to cook or water begins to boil.

Never leave a surface cooking operation unattended especially when using a high heat setting or when deep fat frying. Boilovers cause smoking and greasy spillovers may ignite. Clean up greasy spills as soon as possible. Do not use high heat for extended cooking operations.

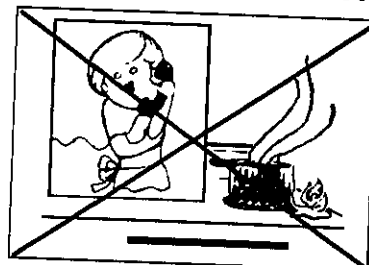

Always let quantities of hot fat used for deep fat frying cool before attempting to move or handle.

Never heat an unopened container as pressure build-up may cause container to burst resulting in serious personal injury or damage to the appliance.

Use dry, sturdy pot holders. Moist or damp pot holders on hot surfaces may cause burns from steam. Do not let pot holders touch hot heating elements. Do not use a towel or other bulky cloth.

Do not let cooking grease or other flammable materials accumulate in or near the appliance, vent hood or vent fan. Clean hood frequently to prevent grease from accumulating on hood or filter. When flaming foods under the hood turn the fan off as the fan may spread the flame.

Use caution when wearing garments made of flammable material to avoid clothing fires. Loose fitting or long hanging-sleeved apparel should not be worn while cooking. Clothing may ignite or catch utensil handles.

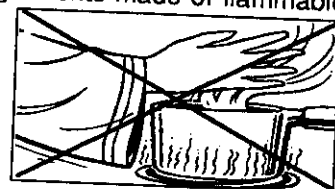

Always place oven racks in the desired positions while oven is cool. Slide oven rack out to add or remove food; avoid reaching into the oven. If a rack must be moved while oven is hot, use a dry pot holder and avoid touching hot element in oven.

Use care when opening the oven door. Let hot air or steam escape before removing or replacing food.

**PREPARED FOOD WARNING:** Follow food manufacturer's instructions. If a plastic frozen food container and/or its cover distorts, warps, or is otherwise damaged during cooking, immediately discard the food and its container. The food could be contaminated.

# IMPORTANT SAFETY INSTRUCTIONS

## UTENSIL SAFETY

Use proper pan size. This appliance is equipped with one or more surface elements of different sizes. Select utensils having flat bottoms large enough to cover the surface element. The use of undersized utensils will expose a portion of the heating element to direct contact and may result in ignition of clothing. Proper relationship of utensil to element will also improve efficiency.

Use pans with flat bottoms and handles that are easily grasped and stay cool. Avoid using unstable, warped, easily tipped or loose handled pans. Pans that are heavy to move when filled with food may also be hazardous.

Be sure utensil is large enough to properly contain food and avoid boilovers. Pan size is particularly important in deep fat frying. Be sure pan will accommodate the volume of food that is to be added as well as the bubble action of fat.

To minimize burns, ignition of flammable materials and spillage due to unintentional contact with the utensil, do not extend handles over adjacent surface elements. Always turn pan handles toward the side or back of the appliance, not out into the room where they are easily hit or reached by small children.

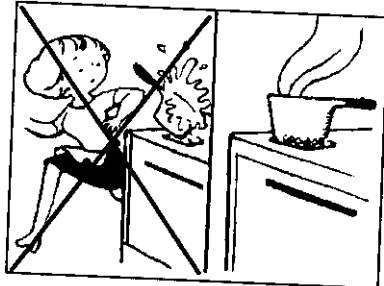

Never let a pan boil dry as this could damage the utensil and the appliance.

Follow the manufacturer's directions when using oven cooking bags.

Only certain types of glass, glass/ceramic, ceramic, earthenware or glazed utensils are suitable for cooktop or oven usage without breaking due to the sudden change in temperature.

This appliance has been tested for safe performance using conventional cookware. Do not use any devices or accessories that are not specifically recommended in this manual. Do not use eyelid covers for the surface units, stove top grills, or add-on oven convection systems. The use of devices or accessories that are not expressly recommended in this manual can create serious safety hazards, result in performance problems, and reduce the life of the components of the appliance.

## CLEANING SAFETY

Turn off all controls and wait for appliance parts to cool before touching or cleaning them. Clean appliance with caution. Use care to avoid steam burns if a wet sponge or cloth is used to wipe spills on a hot surface. Some cleaners can produce noxious fumes if applied to a hot surface.

Do not soak or immerse removable heating elements in water. Immersing element in water would damage element and insulating material inside element.

Do not use aluminum foil or foil liners to line drip bowls, cover an oven rack or line the oven bottom. Improper use of these liners may result in a risk of electric shock, or fire and may cause oven to overheat. Use foil only as recommended in this manual.

## SAVE THESE INSTRUCTIONS

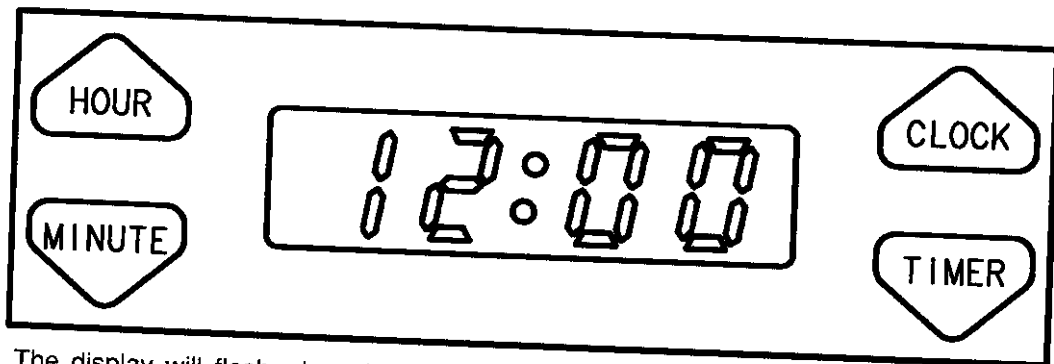

The display will flash when the appliance is first connected to power or if power is interrupted. The display will stop flashing once the time-of-day clock has been set.

#### TO SET THE TIME-OF-DAY CLOCK

1. Press the CLOCK pad.
2. Press and hold the HOUR pad to set the correct hours. Tap the pad once to change the time by a single hour.
3. Press and hold the MINUTE pad to set the correct minutes. Tap the pad once to change the time by a single minute.

For example: To set the clock for 3:15, press and hold the HOUR pad until 3 appears in the hours display. Then press and hold the MINUTE pad until 15 appears in the minutes display.

#### TO SET THE TIMER

1. Press the TIMER pad. 0:59 or one hour will appear in the display.  
The timer will automatically begin counting down in increments of one minute.
  2. **To set the timer for less than one hour**, press the TIMER pad then press and hold the MINUTE pad until the desired time appears in the display. Tap the pad once to change the time by a single minute.
  3. **To set the timer for more than one hour**, press the TIMER pad then –
    - Press the HOUR pad, 1:59 or two hours will appear in the display.
    - Press the MINUTE pad until the desired minutes appear in the display.
  4. When the time has elapsed, 0:00 will appear in the display and continuous beeps will sound indicating the end of the timing operation.
  5. Press the CLOCK pad to cancel the beeps. The current time of day will reappear in the display.
- To cancel the timer:** Press the CLOCK pad and the display will return to the current time of day.

## CONTROL KNOBS

Your cooktop is equipped with control knobs that provide an infinite choice of settings from LOW to HIGH. The knob can be set on or between any of the numbered settings.

**To operate:** Push in and turn the knob in either direction to the desired setting. An indicator light will glow when a surface element is turned on. The indicator light will remain on until the element is turned off. After a cooking operation, be sure the element and indicator light are off.

## GENERAL COOKING TIPS

To prevent damage to the range or utensil, never operate surface unit without a pan in place, never allow a pan to boil dry and never operate an element on HIGH for extended periods of time.

Food will not cook any faster at a higher setting than needed to maintain a gentle boil. Water boils at the same temperature whether boiling gently or vigorously. If a high setting is used, excessive spattering will occur and food may stick or burn onto the bottom of the pan.

If a higher heat setting is used to bring liquid to a boil or to begin cooking, always **reduce** to a lower setting once liquid comes to a boil or food begins cooking. **Never leave food unattended during a cooking operation.**

Fit the size of the cookware to the size of the element. This conserves energy.

## CANNING

Use HIGH just until water comes to a boil or pressure is reached in the pressure canner. Then, **reduce** to the lowest heat setting that maintains the boil or pressure. Prolonged use of HIGH or the use of incorrect canning utensils will produce excessive heat. Excessive heat can cause permanent damage to the porcelain cooktop, coil element and the drip bowl. See page 9 for additional information.

## COOKWARE

Cooking performance is greatly affected by the type of cookware used. Proper cookware will reduce cooking times, use less energy and produce more even cooking results. For best results use a heavy gauge metal pan with a smooth flat bottom and a tight fitting lid.

Cookware with uneven, warped, or grooved bottoms do not make good contact with the heating surface, will reduce heat conductivity and result in slower, less even heating.

Different types of cookware materials require different heat settings for the same cooking operation. The chart below is based on heavy gauge aluminum cookware. Lower the heat setting if using a thinner gauge metal or other materials.

Oversized cookware and cookware that rests across two elements are not recommended as they may trap enough heat to cause damage to the cooktop or elements. This is especially important when canning.

Do not use woks equipped with round metal rings. The ring, which is designed to support the wok above the element, will trap heat and may damage the element and the cooktop.

## SUGGESTED HEAT SETTING GUIDE

Refer to cookware manufacturer's recommendations for suggested heat settings. Some manufacturers do not recommend the use of HIGH, or the use of HIGH for extended cooking operations.

HEAT SETTINGS	USES
HIGH	To bring liquid to a boil, blanch, preheat skillet, or reach pressure in a pressure cooker. <b>Always</b> reduce to a lower heat setting when liquids just begin to boil or foods begin to cook.
Medium-High 7-9	To brown or sear meat; heat oil for deep fat frying; scald; to saute or fry. Maintain fast boil for large amounts of liquids.
Medium 4-6	To maintain moderate to slow boil for large amounts of liquids. To continue cooking uncovered foods and for most frying operations.
Medium-Low 1-3	To continue cooking covered foods and to maintain pressure in most pressure cookers. Stew, braise or steam operations. To maintain boil for small amounts of liquid, poach, steam or simmer.
LOW	To keep foods warm before serving. Melt chocolate.

**COOKING AREAS**

The four cooking areas on your range are identified by permanent patterns in the cooktop. There are two large (8-inch) and two small (6-inch) areas. The patterns on your cooktop may not look like the cooktop in this illustration but your cooktop will operate as described in this manual.

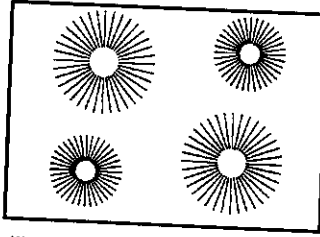

Before using the cooktop for the first time, clean it thoroughly as directed on the cleaning chart on page 15. This will protect the smoothtop and will guarantee a clean cooktop when the elements are turned on.

During the first few hours of use, you may notice that the cooktop emits a slight burning odor and a light smoke. Both of these conditions are normal.

When a cooking area is turned on, the coil element under the cooktop will heat up and glow red. To maintain the heat setting the element will cycle on and off. It is normal to see a red glow through the smoothtop when the element cycles on.

**HOT SURFACE LIGHT**

Your range is equipped with a HOT SURFACE light located at the center-back of the smoothtop. This red light will turn on to indicate that the smoothtop is hot and will remain on until the top has cooled.

**RETAINED HEAT**

The smoothtop cooking area retains heat for a period of time after the element has been turned off. Turn the element off a few minutes before food is completely cooked and use the retained heat to complete the cooking operation. After 30 minutes, the cooktop may be too cool to keep foods warm. However, the TOP MAY STILL BE TOO WARM TO TOUCH. When the HOT SURFACE light turns off, the top will be cool enough to touch.

**COOKING TIPS**

When cooking delicate foods which easily scorch or overcook, start with a lower heat setting then gradually increase the setting until you find the optimum setting. Boilovers are more likely to occur if you start out on HIGH then reduce to the lower setting. If you do begin cooking on HIGH, reduce to a lower setting before liquids come to a full boil.

If food is cooking too fast or if a boilover occurs, remove lid or remove cookware from cooking area and reduce to a lower setting. Allow enough time for the cooking area to adjust to the new setting.

**COOKWARE TIPS**

**Aluminum foil** will damage the smoothtop if it melts onto the glass. Do not use aluminum foil or foil-type disposable containers such as popcorn poppers under any circumstances. They may leave metal marks or may permanently melt onto the smoothtop. Do not use cooktop if metal or aluminum foil melts onto the smoothtop. Call an authorized servicer. Do not attempt to repair cooktop yourself.

**Aluminum cookware** will cause metal marks on the glass if you slide them across the smoothtop. Remove any metal marks immediately using Cooktop Cleaning Creme.

**Glass ceramic, earthenware, porcelain over metal, heat-proof glass or glazed cookware** may scratch the smoothtop cooktop if you slide them across the top.

**TO PROTECT SMOOTHTOP**

- Do not use the top as a work surface or as a cutting board. Do not cook food directly on the cooktop.
- Do not use a trivet or metal stand (such as a wok ring) between the utensil and the cooktop. These items can mark or etch the surface and affect cooking efficiency.
- Do not place plastics on a warm or hot cooking area. They will melt and adhere to the smoothtop. The smoothtop may chip or pit in attempting to remove melted plastic from the top.
- To prevent scratching or damage to the smoothtop, do not leave sugar, salt, sand, soil, shortening or other fats on the cooking area. Be sure area is free from these before turning on cooking area.
- Be sure the bottom of the cookware is smooth and free of nicks, scratches or rough areas as they may scratch the smoothtop.
- Do not allow a pan to boil dry. This could cause permanent damage to the smoothtop.

## CARE INFORMATION

To help keep cooktop clean, be sure cooking area and cookware bottom are clean and dry before each use.

To prevent possible damage to the cooktop, always rinse the bottom of cookware to completely remove any cleaning agent residue. This is especially important when using a copper or aluminum cleaner. In the presence of heat, the cleaning residue may stain, discolor or etch the smoothtop.

Carefully blot up spillovers around the outside of the cooking area as they occur with dry paper towels. **BE CAREFUL NOT TO BURN HANDS WHEN WIPING UP SPILLS. DO NOT USE A DAMP CLOTH WHICH MAY CAUSE STEAM BURNS.**

**CAUTION:** Do not use cooktop if the smoothtop is cracked, broken, or if metal melts onto the cooktop. Call an authorized servicer. Do not attempt to repair the cooktop yourself.

When surface is cool, clean as directed in the chart on page 15. **DO NOT USE** the following cleaning agents:

- Abrasives (metal scouring pads, cleansing powders, scouring cleaners or pads) will scratch the smoothtop.
- Chemicals (oven cleaners, chlorine bleaches, rust removers or ammonia) may damage the finish of the smoothtop.
- Glass cleaners containing ammonia may harm the smoothtop.
- Soiled cloth or sponge will leave an invisible film on the cooktop which may scratch or cause discoloration the next time the cooktop is used.

**IMPORTANT:** Watch sugary solutions carefully to avoid boilovers. If a sugar solution (such as jam, jelly, candy) boils over, it may pit the smoothtop. Turn element to **LOW** and clean sugary boilovers **immediately**. See page 15 for complete cleaning instructions.

## PROBLEM SOLVING CHART

PROBLEM	CAUSE	TO PREVENT
Tiny scratches or abrasions	Coarse particles (dust, salt and sand) between cookware bottom and cooktop. Incorrect cleaning materials. Sliding glassware or metal across top or using cookware with rough bottoms.	Tiny scratches are not removable and do not affect cooking. In time, the scratches will become smoother and less visible. Be sure cookware bottoms and cooktop are clean before use. Use cookware with a smooth, non-scratching bottom. Do not slide cookware across cooktop.
Metal-marking	Sliding or scraping metal utensils or oven racks across cooktop.	Do not slide metal object across cooktop. When cool, clean with Cooktop Cleaning Creme.
Brown streaks and specks	Boilovers, incorrect cleaning materials, used soiled cloth or sponge, soiled cookware.	Remove boilovers before reusing the cooktop. Use a clean cloth or sponge. Be sure cookware, especially bottoms, are clean and dry.
Areas of discoloration with a metallic sheen	Mineral deposits from water and foods.	Use cookware with bottoms that are clean and dry. Use correct heat setting to prevent boilovers.
Pitting or flaking.	Sugary boilovers from sugar syrups, candy, jams, jellies, dessert sauces, etc.	Use correct heat setting and large enough utensil. Watch cooking operation to prevent boilovers or spattering.

# COIL ELEMENT COOKTOP, if equipped

## COIL SURFACE ELEMENTS

- Coil surface elements are self-cleaning.
- Do not immerse elements in water.
- When an element is turned on, it will cycle on and off to maintain the heat setting.
- To prevent damage to the range, NEVER operate surface element without a pan in place and NEVER allow a pan to boil dry.

**To remove:** When cool, raise element and carefully pull out and away from the receptacle.

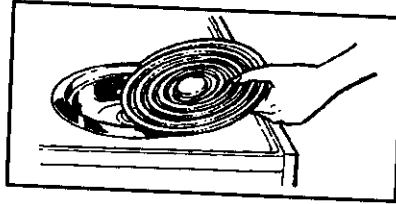

**To replace:** Insert the terminals on the element into the receptacle. Gently lift up on outer edge of element (opposite terminal-side of element) while inserting terminals into receptacle. Gently press down on outer edge of element until element sits level on drip bowl.

Be sure drip bowls are properly installed. Notch on trim ring should be centered over the screw securing the receptacle to the maintop. If trim ring is not installed properly and rests on this screw, the trim ring and drip bowl will "rock".

## DRIP BOWLS

- Be sure drip bowls, located under each element, are in place.
- Absence of these bowls during cooking may subject wiring or component parts underneath the cooktop to damage.
- To prevent risk of electric shock or fire, do not line drip bowls with aluminum foil.

Your range will be equipped with either chrome plated or porcelain coated steel drip bowls.

Chrome drip bowls will turn blue or gold over time or if overheated. This type of discoloration is permanent and will not affect cooking performance.

To protect the chrome or porcelain finish, avoid using high settings for long periods of time. Reduce to a lower setting once food begins cooking. Do not use oversized cookware. Pan should not extend more than 2 inches from the element.

If the oven vent is located under the right rear element, be sure the drip bowl for this element has a hole in the center to allow proper oven venting. To prevent baking problems, never block the vent opening by placing a solid drip bowl in this location or by covering the hole in the center of the drip bowl with aluminum foil.

## CANNING ELEMENT ACCESSORY KIT

(MODEL CE1)

The use of oversized cookware or large canners on the coil element cooktop may result in damage to the porcelain enamel finish. A special canning element has been designed to protect the finish when using this type of cookware. The canning element and chrome drip bowl are available as an optional accessory kit.

For information on the Canning Element Accessory Kit, contact your dealer or write to Maytag Customer Service, P.O. Box 2370, Cleveland, TN 37320-2370.

**NOTE:** For additional canning information contact your local County Extension Office. Or, contact Alltrista Consumer Products Company, marketer of Ball brand home canning products at 800-240-3340 or write: Alltrista Corp., Consumer Affairs Dept., P.O. Box 2729, Muncie, IN 47307-0729.

## OVEN LIGHT, if equipped

The oven light switch is located on the control panel. To turn the oven light on, push in the bottom half of the switch.

## OVEN VENT

The oven vent is located at the rear of the cooktop or under the right rear surface element. When the oven is in use, this area may feel warm or hot to the touch. To prevent baking problems, do not block the vent opening.

## OVEN CHARACTERISTICS

Because each oven has its own personal baking characteristics, do not expect that your new oven will perform exactly like your previous oven. You may find that the cooking times, oven temperatures, and cooking results differ somewhat from your previous range. Allow a period of adjustment. If you have questions concerning baking results, please refer to pages 11, 12, 13 and 19 for additional information.

## OVEN CONTROLS

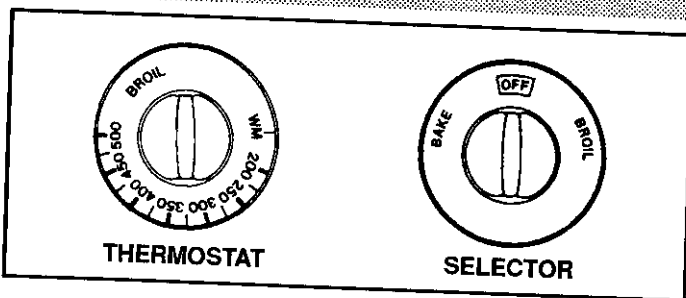

NOTE: The knobs on your range may not look like the knobs in the above illustration. However, they will operate as described below.

The THERMOSTAT knob is used to select and maintain the oven temperature. Always turn this knob just TO the desired temperature. Do not turn to a higher temperature and then back.

The SELECTOR knob, if equipped, determines the type of oven operation. Turn this knob to the desired setting. Each setting is identified by an indent (stop) and a "click" sound.

To turn the oven on, **both** the Thermostat and Selector knobs, if equipped, must be set. The oven will not operate if the Selector knob is left in the OFF position. To turn the oven off, turn the Selector knob, if equipped, or the Thermostat knob to the OFF position.

## OVEN INDICATOR LIGHT

The OVEN indicator light, located on the backguard, turns on whenever the oven is turned on. When the oven reaches the preset temperature, the indicator light will turn off and on as the oven elements cycle off and on.

## HOW TO SET OVEN TO BAKE OR ROAST

1. When cool, position the racks in the oven.
2. Turn the Thermostat knob to the desired temperature.
3. Turn the Selector knob, if equipped, to BAKE.
4. Place the food in the center of the oven, allowing a minimum of 2 inches between the utensil and the oven walls.  
When the oven is in use, the oven vent area may feel warm or hot to the touch. Do not block this area or the vent opening as this may affect baking results.
5. Check food for doneness at the minimum time in the recipe. Cook longer if necessary. Cooking time may vary from oven to oven.
6. Remove food from the oven and turn the Thermostat knob or the Selector knob, if equipped, to OFF.

## PREHEATING

Preheating is necessary for baking. Allow about 10 to 15 minutes for the oven to preheat. It is not necessary to preheat for roasting.

Selecting a temperature higher than desired will NOT preheat the oven any faster, and may have a negative effect on baking results.

## USE OF ALUMINUM FOIL

**Do not cover the oven bottom or an entire rack with foil or place foil directly under cookware.** To catch spillovers, place a piece of foil a little larger than the pan, on the rack below the pan. For ranges with one rack, it will be necessary to place the foil directly under the utensil. Cut a small opening in the foil to allow heat to the bottom of the pan. This is especially important when baking pies.

**OVEN RACKS**

Your range will feature one or two oven racks. The oven rack is designed with a safety lock-stop position to keep the rack from accidentally coming completely out of the oven when pulling the rack out to add or remove food.

**CAUTION:** Do not attempt to change the rack positions when the oven is hot.

**To remove:** Be sure the rack is cool. Pull the rack straight out until it stops at the lock-stop position. Tilt the front end of the rack up and continue pulling the rack out of the oven.

**To replace:** Place the rack on the rack supports and tilt the front end of the rack up slightly. Slide it back until it clears the lock-stop position. Lower the front and slide the rack straight in. Pull the rack out to the lock-stop position to be sure it is positioned correctly and then return it to its normal position.

It is important that air can circulate freely within the oven and around the food. To help ensure this, place food on the center of the oven rack. Allow two inches between the edge of the utensil(s) and the oven walls.

For optimum baking results of cakes, cookies or biscuits use one rack. Position the rack so the food is in the center of the oven. Use either rack position 2 or 3.

If cooking on more than one rack, stagger the food to ensure proper air flow.

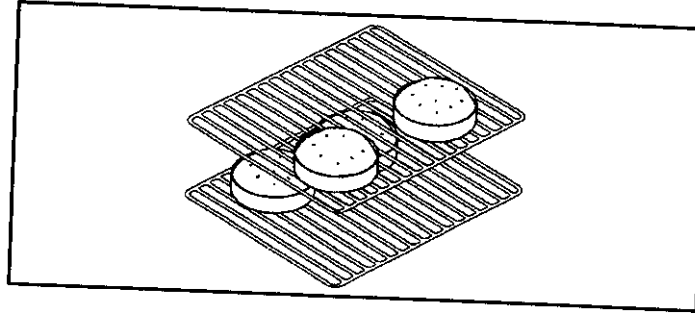

If cooking on two racks, use rack positions 2 and 4 for cakes and rack positions 1 and 4 when using cookie sheets. Never place two cookie sheets on one rack.

If roasting a large turkey, place the turkey on rack 1 and the side dishes on rack 5.

**RACK POSITIONS**

<b>RACK 5</b> (highest position)	Used for toasting bread, or for two-rack baking.
<b>RACK 4</b>	Used for most broiling and two-rack baking.
<b>RACK 3</b>	Used for most baked goods on a cookie sheet or jelly roll pan, or frozen convenience foods, or for two-rack baking.
<b>RACK 2</b>	Used for roasting small cuts of meat, large casseroles, baking loaves of bread, cakes (in either tube, bundt, or layer pans) or two-rack baking.
<b>RACK 1</b>	Used for roasting large cuts of meat and large poultry, pies, souffles, or angel food cake, or for two-rack baking.

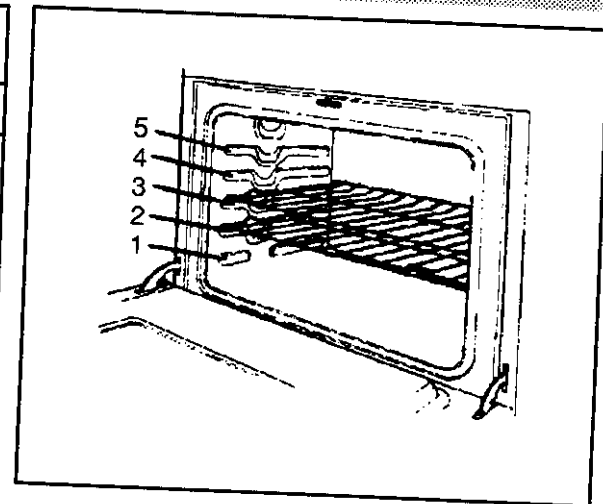

## COMMON BAKING PROBLEMS AND WHY THEY HAPPEN

PROBLEM	CAUSE
<i>Cakes are uneven.</i>	<ul style="list-style-type: none"> <li>• Pans too close or touching each other or oven walls.</li> <li>• Batter uneven in pans.</li> <li>• Temperature set too low or baking time too short.</li> <li>• Oven not level.</li> <li>• Undermixing.</li> <li>• Too much liquid.</li> </ul>
<i>Cake high in middle.</i>	<ul style="list-style-type: none"> <li>• Temperature set too high.</li> <li>• Baking time too long.</li> <li>• Overmixing.</li> <li>• Too much flour.</li> <li>• Pans touching each other or oven walls.</li> <li>• Incorrect rack position.</li> </ul>
<i>Cake falls.</i>	<ul style="list-style-type: none"> <li>• Too much shortening or sugar.</li> <li>• Too much or too little liquid.</li> <li>• Temperature set too low.</li> <li>• Old or too little baking powder.</li> <li>• Pan too small.</li> <li>• Oven door opened frequently.</li> <li>• Added incorrect type of oil to cake mix.</li> <li>• Added additional ingredients to cake mix or recipe.</li> </ul>
<i>Cakes, cookies, biscuits don't brown evenly.</i>	<ul style="list-style-type: none"> <li>• Incorrect rack position.</li> <li>• Oven door not closed properly.</li> <li>• Door gasket not sealing properly or properly attached to door.</li> <li>• Incorrect use of aluminum foil.</li> <li>• Oven not preheated.</li> <li>• Pans darkened, dented or warped.</li> </ul> <p>For optimum results, bake on one rack. If baking cakes on two racks, place pans toward the front of the oven on the upper rack and toward the back of the oven on the lower rack.</p>
<i>Cakes, cookies, biscuits too brown on bottom.</i>	<ul style="list-style-type: none"> <li>• Oven not preheated.</li> <li>• Pans touching each other or oven walls.</li> <li>• Incorrect rack position.</li> <li>• Incorrect use of aluminum foil.</li> <li>• Placed 2 cookie sheets on one rack.</li> <li>• Used glass, dark, stained warped or dull finish metal pans. (Use a shiny cookie sheet.)</li> </ul> <p>Follow cookware manufacturer's instructions for oven temperature. Glassware and dark cookware such as Ecko's Baker's Secret may require lowering the oven temperature by 25°F.</p>
<i>Cakes don't brown on top.</i>	<ul style="list-style-type: none"> <li>• Incorrect rack position.</li> <li>• Temperature set too low.</li> <li>• Overmixing.</li> <li>• Too much liquid.</li> <li>• Pan size too large or too little batter in pan.</li> <li>• Oven door opened too often.</li> </ul>
<i>Excessive shrinkage.</i>	<ul style="list-style-type: none"> <li>• Too little leavening.</li> <li>• Overmixing.</li> <li>• Pan too large.</li> <li>• Temperature set too high.</li> <li>• Baking time too long.</li> <li>• Pans too close to each other or oven walls.</li> </ul>
<i>Uneven texture.</i>	<ul style="list-style-type: none"> <li>• Too much liquid.</li> <li>• Undermixing.</li> <li>• Temperature set too low.</li> <li>• Baking time too short.</li> </ul>
<i>Cakes have tunnels.</i>	<ul style="list-style-type: none"> <li>• Not enough shortening.</li> <li>• Too much baking powder.</li> <li>• Overmixing or at too high a speed.</li> <li>• Temperature set too high.</li> </ul>
<i>Cake not done in middle.</i>	<ul style="list-style-type: none"> <li>• Temperature set too high.</li> <li>• Pan too small.</li> <li>• Baking time too short.</li> </ul> <p>If additional ingredients were added to mix or recipe, expect cooking time to increase.</p>
<i>Pie crust edges too brown.</i>	<ul style="list-style-type: none"> <li>• Temperature set too high.</li> <li>• Pans touching each other or oven walls.</li> <li>• Edges of crust too thin; shield with foil.</li> </ul>
<i>Pies don't brown on bottom.</i>	<ul style="list-style-type: none"> <li>• Used shiny metal pans.</li> <li>• Temperature set too low.</li> <li>• Incorrect rack position.</li> <li>• Some frozen pies should be placed on a cookie sheet, check package directions.</li> </ul>
<i>Pies have soaked crust.</i>	<ul style="list-style-type: none"> <li>• Temperature too low at start of baking.</li> <li>• Filling too juicy.</li> <li>• Used shiny metal pans.</li> </ul>

**BAKING TIPS**

Use a **reliable recipe** and accurately measure fresh ingredients. **Carefully follow directions** for oven temperature and cooking time. Preheat oven if recommended.

Use the **correct rack position**. Baking results may be affected if the wrong rack position is used.

- \* Top browning may be darker if food is located toward the top of the oven.
- \* Bottom browning may be darker if food is located toward the bottom of the oven.
- \* When using two racks for baking, allow enough space between the racks for proper air circulation. Browning and cooking results will be affected if air flow is blocked.

**Cookware material** plays an important part in baking results. Always use the type and size of pan called for in the recipe. Cooking times or cooking results may be affected if the wrong size is used.

- \* **Shiny metal pan** reflects heat away from the food, produces lighter browning and a softer crust. Use shiny pans for baking cakes or cookies. For optimum baking results, bake cookies and biscuits on a **flat** cookie sheet. If the pan has sides, such as a jelly roll pan, browning may not be even.
- \* **Dark metal pan or a pan with an anodized (dull) bottom** absorbs heat, produces darker browning and a

crisper crust. Use this type of pan for pies, pie crusts or bread.

- \* If using **oven-proof glassware**, or **dark pans such as Baker's Secret** reduce the oven temperature by 25° except when baking pies or bread. Use the same baking time as called for in the recipe.

**Allow hot air to flow freely through the oven** for optimum baking results. Improper placement of pans in the oven will block air flow and may result in uneven browning. For optimum browning and even cooking results:

- \* Do not crowd a rack with pans. Never place more than one cookie sheet, one 13x9x2-inch cake pan or two 9-inch round cake pans on one rack.
- \* Stagger pans when baking on two racks so one pan is not directly over another pan.
- \* Allow one to two inches between the pan and the oven walls.

**Check the cooking progress at the minimum time** recommended in the recipe. If necessary, continue checking at intervals until the food is done. If the oven door is opened too frequently, heat will escape from the oven; this can affect baking results and wastes energy.

**If you add additional ingredients** or alter the recipe, expect cooking times to increase or decrease slightly.

**ROASTING TIPS**

Roasting is the method for cooking large, tender cuts of meat uncovered, without adding moisture. Most meats are roasted at 325°F. It is not necessary to preheat the oven. Place the roasting pan on either of the two lowest rack positions, ~~or on the special roasting position (see page 6).~~

Use tender cuts of meat weighing three pounds or more. Some good choices are: Beef rib, ribeye, top round, high quality tip and rump roast, pork loin roast, leg of lamb, veal shoulder roast and cured or smoked hams.

Season meat, if desired, either before or after roasting. Rub into the surface of the roast if added before cooking.

Place the meat **fat-side-up** on a rack in a shallow roasting pan. Placing the meat on a rack holds it out of the drippings, thus allowing better heat circulation for even cooking. As the

fat on top of the roast melts, the meat is basted naturally, eliminating the need for additional basting.

The cooking time is determined by the weight of the meat and the desired doneness. For more accurate results, use a meat thermometer. Insert it so the tip is in the center of the thickest part of the meat. It should not touch fat or bone.

Remove the roast from the oven when the thermometer registers approximately 5°F below the doneness wanted. As the meat stands, the temperature will rise.

**NOTE:** For more information about food safety, call USDA's Meat & Poultry Hotline at 1-800-535-4555. For cooking information write to the National Live Stock and Meat Board, 444 North Michigan Avenue, Chicago, Illinois 60611.

## BROILING

Broiling is a method of cooking tender meats by direct heat. The cooking time is determined by the distance between the meat and the broil element, the desired degree of doneness and the thickness of the meat.

### Broiling Tips

Broiling requires the use of the broiler pan and insert. The broiler insert must be in place to allow fat and liquid to drain to the pan below to prevent spatters, smoke and flare-ups. Improper use may cause grease fires.

For easier clean up, line the broiler pan with foil and spray the insert with a non-stick vegetable spray. Do not cover the broiler insert with aluminum foil as this prevents fat from draining into pan below.

Trim excess fat and slash remaining fat to help keep meat from curling and to reduce smoking and spattering. Season meat after cooking.

Place oven rack in the correct rack position when oven is cool. For darker browning, place meat closer to the broil element. Place meat further down if you wish meat to be well done or if excessive smoking or flaring occurs.

See Care and Cleaning Chart on page 14 for instructions on cleaning the broiler pan and insert.

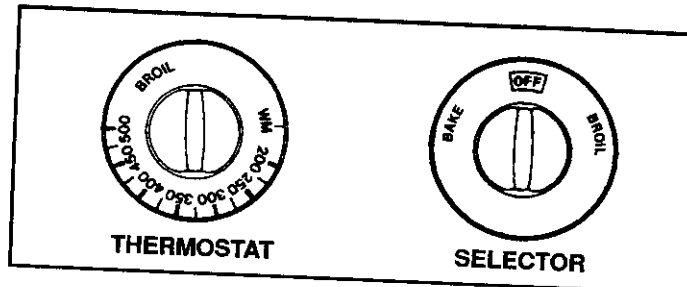

### To Set Oven To Broil:

1. Place the oven rack in the recommended rack position.
2. Turn the Thermostat knob to BROIL or, for lower temperature broiling, to 450°F.
3. Turn the Selector knob, if equipped, to BROIL.
4. If desired, preheat the broil element for about 3 minutes before placing the meat in the oven.
5. Follow the suggested times in the chart below. Turn meat once about halfway through cooking.
6. Check for doneness by cutting a slit near the center of the meat.
7. After broiling, turn the oven off and remove the broiler pan from the oven.

NOTE: Broil times may increase if the range is installed on 208 volts.

## BROILING CHART

TYPE OF MEAT	RACK POSITION*	DONENESS	TOTAL TIME (MINUTES)**
BACON	#4	Well Done	6 to 10
BEEF STEAKS 1-inch thick	#4	Medium Well Done	15 to 18 19 to 23
CHICKEN Pieces	#3 or #4	Well Done	Broil at 450°F 30 to 45
FISH Fillets Steaks, 1-inch thick	#4	Flaky Flaky	8 to 12 10 to 15
GROUND BEEF PATTIES 3/4-inch thick	#4	Well Done	15 to 18
HAM SLICE, precooked 1/2-inch thick	#4	Warm	8 to 12
PORK CHOPS 1-inch thick	#4	Well Done	22 to 26

\* The top rack position is position #5.

\*\* Broiling times are approximate and may vary depending on the meat.

# CARE AND CLEANING CHART

## ABOUT CLEANING PRODUCTS

Because of the many new cleaning products introduced in the marketplace each year, it is not possible to list all products that can be safely used to clean this appliance.

ALWAYS READ THE MANUFACTURER'S INSTRUCTIONS to be sure the cleaner can be safely used on this appliance. Also, read and carefully follow the manufacturer's directions when using any cleaning product.

To determine if a cleaning product is safe, test a small inconspicuous area using a very light pressure to see if the surface may scratch or discolor. This is particularly important for porcelain enamel, metal, plastic or highly polished, shiny, or painted surfaces.

The following brands may help you to make an appropriate selection:

**Glass Cleaners** – Bon Ami, Cinch, Glass Plus, Windex.

**Dishwashing Liquid Detergents** – Dawn, Dove, Ivory, Joy.

**Mild Liquid Spray Cleaners** – Fantastik, Formula 409.

**Non-Abrasive Cleaners** – Bon Ami, paste of baking soda and water.

**Mildly Abrasive Powder or Liquid Cleansers** – Ajax, Barkeepers Friend, Cameo, Comet, Soft Scrub.

**Non-Abrasive or Scratchless Plastic or Nylon Scouring Pads or Sponges** – Chore Boy Plastic Cleaning Puff, Scrunge Scrub Sponges, or Scotch-Brite No Scratch, Cookware or Kitchen Sponge.

**Abrasive Scouring Pads** – S.O.S., Brillo Steel Wool Soap, Scotch-Brite Wool Soap Pads.

*(Brand names for the above cleaning products are registered trademarks of the respective manufacturers.)*

Be sure appliance is off and all parts are cool before handling or cleaning to avoid damage and possible burns. If a part is removed, be sure it is correctly replaced.

To prevent staining or discoloration, clean cooktop after each use.

## CARE AND CLEANING CHART

PARTS	CLEANING AGENTS	DIRECTIONS
<b>Baked Enamel:</b> <ul style="list-style-type: none"> <li>• Side panels</li> <li>• Storage drawer</li> <li>• Oven door</li> <li>• Backguard</li> </ul>	<ul style="list-style-type: none"> <li>• Detergent and water</li> <li>• Mild liquid cleaner</li> <li>• Glass cleaner</li> </ul>	Use a dry paper towel or cloth to wipe up spills, especially acid spills, as soon as they occur. This is especially important for white surfaces. When surface is cool, wash with detergent and water. Do not use abrasive or harsh cleaning liquids and powders or oven cleaners. These will scratch and permanently damage the finish. Dry with a soft cloth. On smoothtop cooktops, clean vent opening area after each oven use.
<b>Broiler Pan and Insert</b>	<ul style="list-style-type: none"> <li>• Detergent and water</li> <li>• Plastic or soap-filled scouring pad</li> <li>• Dishwasher</li> </ul>	Pretreat the broiler pan and insert with a non-stick vegetable coating such as Pam or Mazola to make cleaning easier.  Remove from oven after use. Cool then pour off grease. Place soapy cloth over insert and pan; let soak to loosen soil. Wash in warm soapy water. Use soap filled scouring pad to remove stubborn soil. Broiler pan and insert can be cleaned in the dishwasher.
<b>Continuous Clean Oven, if equipped</b>		Follow instructions on page 18 for the Continuous Clean Oven.
<b>Control Knobs</b>	<ul style="list-style-type: none"> <li>• Detergent and water</li> <li>• Mild liquid sprays</li> <li>• Glass cleaners</li> </ul>	For ease of cleaning, turn off knob and remove by pulling forward. Wash, rinse, and dry. Do not use abrasive cleaning agents as they may scratch the finish and remove the markings. Turn on each element to be sure knobs have been correctly replaced.
<b>Drip Bowls, Chrome</b> <ul style="list-style-type: none"> <li>• Brown food stains</li> </ul> <ul style="list-style-type: none"> <li>• Blue/gold heat stains</li> </ul>	<ul style="list-style-type: none"> <li>• Detergent and water</li> <li>• Plastic scouring pads</li> <li>• Mild abrasive cleaners</li> </ul> <ul style="list-style-type: none"> <li>• Flitz Metal Polish (Follow package directions)</li> </ul>	After each use, wash, rinse and dry to prevent difficult soils. If heavily soiled, gently scrub with plastic scouring pad. If soil is allowed to burn on, it may be impossible to remove.  <b>Do not cover with aluminum foil.</b>  These stains are caused by overheating, and normally occur over a period of time. They are usually permanent. To minimize: <ol style="list-style-type: none"> <li>1. Avoid excessive use of the high heat setting. Use HIGH only to start cooking, then lower the setting to finish cooking.</li> <li>2. Use flat bottom pans that do not extend more than two inches from the surface element.</li> </ol> A non-abrasive metal polish such as Flitz may be used to help remove stains. Flitz is available in many automotive supply and hardware stores.

## CARE AND CLEANING CHART, Continued

PARTS	CLEANING AGENTS	DIRECTIONS
<b>Drip Bowls, Porcelain</b>	<ul style="list-style-type: none"> <li>• Detergent and water</li> <li>• Mild abrasive cleaners</li> <li>• Plastic scouring pads</li> <li>• Dishwasher</li> </ul>	After each use, wash, rinse and dry to prevent difficult soils. To clean by hand, soak in hot sudsy water, then use mild abrasive cleaner and plastic scouring pad. <b>Do not cover with aluminum foil.</b>
<b>Elements, Oven and Coil</b>		Elements are self-cleaning. Soil will burn off as elements are used. Do not spray oven cleaner on elements, electrical hook up or connection. Do not immerse coil-type surface elements in water.
<b>Glass</b> • Oven window	<ul style="list-style-type: none"> <li>• Detergent and water</li> <li>• Glass cleaner</li> </ul>	To prevent staining of the oven window, avoid using excessive amounts of water which may seep under or behind glass. Wash with detergent and water. Remove stubborn soil with paste of baking soda and water. Do not use abrasive materials such as scouring pads, steel wool or powdered cleaning agents. They will damage glass. Rinse with clear water and dry.
<b>Metal Finishes</b> • Trim	<ul style="list-style-type: none"> <li>• Detergent and water</li> <li>• Glass cleaner</li> </ul>	Do not use oven cleaner or abrasive agents, as they will damage the finish. Remove stubborn soil with detergent and water. Polish with a soft cloth.
<b>Oven Racks</b>	<ul style="list-style-type: none"> <li>• Detergent and water</li> <li>• Plastic scouring pad</li> <li>• Cleansing powders</li> <li>• Soap-filled scouring pads</li> </ul>	Clean with soapy water. Remove stubborn soil with cleansing powder or soap filled scouring pad. Rinse and dry.
<b>Plastic Finishes</b> • Door handles • Backguard trim • Knobs • End caps	<ul style="list-style-type: none"> <li>• Soap and water</li> <li>• Non-abrasive plastic pad or sponge</li> <li>• Glass cleaner</li> </ul>	When surface is cool, clean with soap and water, rinse, and dry. Use a glass cleaner and a soft cloth. <b>NOTE:</b> Never use oven cleaners, abrasive or caustic liquid or powdered cleansers on plastic finishes. These cleaning agents will scratch or mar finish. <b>NOTE:</b> To prevent staining or discoloration, wipe up fat, grease or acid (tomato, lemon, vinegar, milk, fruit juice, marinade) immediately with a dry paper towel or cloth.
<b>Porcelain Enamel</b> • Cooktop, coil elements • Cooktop trim, smoothtop • Oven interior	<ul style="list-style-type: none"> <li>• Detergent and water</li> <li>• Paste of baking soda and water</li> <li>• Non-abrasive plastic pad or sponge</li> <li>• Oven cleaner, porcelain oven cavity only.</li> </ul>	Porcelain enamel is glass fused on metal and may crack or chip with misuse. Porcelain enamel is acid resistant, not acid proof. All spillovers, especially acidic or sugar spillovers, should be wiped up immediately with a dry cloth. This is especially important around the vent opening for smoothtop cooktop models. Surface may discolor or dull if soil, especially acidic soil, is not removed. Never wipe off a warm or hot surface with a damp cloth. This may cause cracking and chipping. Never use oven cleaners, abrasive or caustic cleaning agents on exterior finish of range or in the Continuous Clean Oven. Use oven cleaner only on porcelain enamel oven interior.
<b>Silicone Rubber</b> • Door gasket	<ul style="list-style-type: none"> <li>• Detergent and water</li> </ul>	Door gasket is located on the door plug. <b>DO NOT REMOVE GASKET.</b> Wash with soap. Rinse thoroughly.
<b>Smoothtop Cooktop</b> • Light to moderate soil  • Heavy soil or brown/gray stains from hard water or metal marks  • Burned-on or crusty soils or residue  • Sugar, plastic, aluminum foil	<ul style="list-style-type: none"> <li>• Cooktop Cleaning Creme</li> <li>• Detergent and water</li> <li>• Paste of baking soda and water</li> <li>• Cooktop Cleaning Creme</li> <li>• Single-edge safety razor blade</li> <li>• Cooktop Cleaning Creme</li> <li>• Single-edge safety razor blade held with a potholder or a wooden handled stainless steel spatula</li> </ul>	Wait until cooktop has cooled before cleaning. Gently apply cleaning agent with a non-abrasive plastic brush, nylon or plastic pad, paper towel or clean cloth. Rinse thoroughly and completely dry.  Gently scrub with cleaning creme and clean cloth or paper towel. Reapply cleaner. Cover with damp paper towels to keep cleaner moist. Let stand for 30 to 45 minutes. Scrub to remove remaining stain. Rinse and dry.  Hold razor blade scraper at 30° angle and very carefully scrape off soil. Clean remaining soil with cleaning creme.  Immediately turn element to LOW and scrape from hot surface to a cool area. Then turn element OFF and cool. Clean residue with razor blade scraper and cleaning creme.  <b>NOTE:</b> Call an authorized servicer if the smoothtop should crack, break or if metal or aluminum foil should melt on the cooktop.

**COOKTOP**

To prevent staining or discoloration, clean cooktop after each use. Wipe acid or sugar stains as soon as the cooktop has cooled as these stains may discolor or etch the porcelain.

Freestanding ranges with a coil element cooktop will feature a lift-up cooktop.

Cooktops on the following models do not lift up: Smooth-top cooktops, slide-in or drop-in ranges and ranges for Canada.

**To raise the cooktop:** When cool, grasp the front edge of the cooktop and gently lift up until the two support rods at the front of the cooktop snap into place.

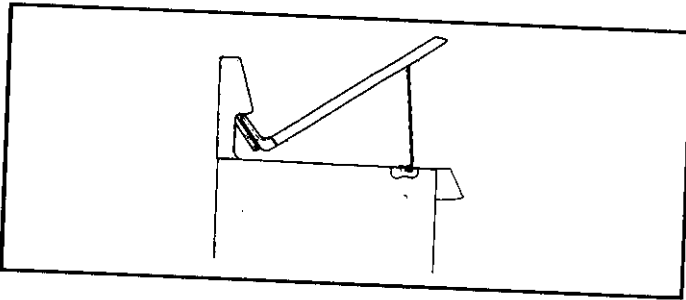

**To lower the top:** Hold the front edge of the cooktop and carefully push back on each support rod to release the notched support. Then gently lower the top into place. The support rods will slide into the range frame.

**OVEN LIGHT, if equipped**

Before replacing the light bulb, **DISCONNECT POWER TO RANGE.** Be sure the bulb is cool. Do not touch a hot bulb with a damp cloth as the bulb may break.

**To turn on oven light:** Push the rocker switch located on the backguard or on the control panel.

**To replace oven light:** Be sure bulb is cool. Use a dry potholder, to prevent possible harm to hands, and very carefully unscrew bulb.

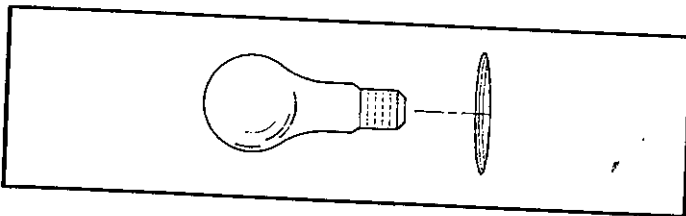

Replace with a 40 watt appliance bulb and reconnect power to range. Reset the clock.

**OVEN DOOR**

Do not place excessive weight on an open oven door or stand on an open oven door as, in some cases, it could cause the range to tip over, break the door or cause serious injury to the user.

When opening the oven door, allow steam and hot air to escape before reaching in oven to check, add or remove food.

Do not attempt to open or close door until the door is completely seated on the hinge arms. Never turn on the oven unless door is properly in place. When baking, be sure the door is completely closed. Baking results will be affected if the door is not securely closed.

**CAUTION:** Hinge arms are spring mounted and will slam shut against the range if accidentally hit. **Never place hand or fingers between the hinges and the front oven frame.** You could be injured if hinge snaps back.

**To remove lift-off door:** When cool, open the door to the "stop" position (opened about 6 inches) and grasp the door at each side. Do not use the door handle to lift the door. Lift up evenly until the door clears the hinge arms.

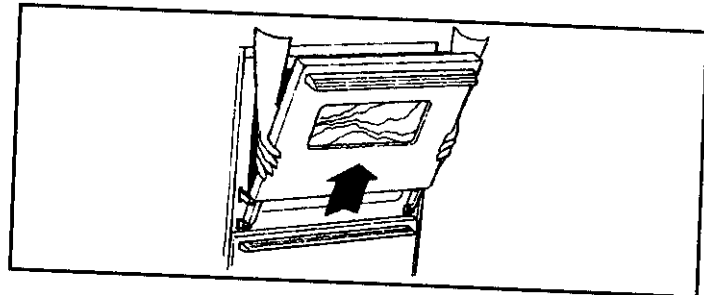

**To replace door:** Grasp the door at each side, align slots in the door with the hinge arms and slide the door down onto the hinge arms until it is completely seated on hinges.

## CONTINUOUS CLEAN OVEN, if equipped

The rough, porous finish of the Continuous Cleaning Oven prevents grease spatters from forming beads which run down the walls leaving unsightly streaks. Rather, the rough texture absorbs spatters and allows them to spread, thus exposing a larger area to the hot oven air. The catalyst, when exposed to heat, speeds the oxidation of soil.

### Factors Affecting Length Of Cleaning Time

Cleaning action automatically begins whenever the oven is turned on for baking or roasting. No cleaning will occur when the oven is off.

The length of cleaning time will depend on: Type of soil, amount or size of soil, oven temperature and length of time oven is in use. Time may vary from a few minutes to several hours. Soil deposited at the end of a cycle may still be visible. This will usually fade with continued oven use until the soil gradually disappears or can be wiped up manually. The oven will appear presentably clean, even though some spatters may be present.

### To Manually Clean Heavy Spillovers

Crusty stains must either be removed or broken up before cleaning can effectively take place. Brush off heavy soil with a nylon brush or plastic pad. **DO NOT USE** paper towels, cloths or sponges for the oven walls are porous and particles of these materials will rub off on the walls. Rinse area with clear water only.

Varnish type stains usually need to be softened with a small amount of water or damp cloth. Remaining soil will gradually reduce with continued oven use at normal baking temperatures.

Do not use oven cleaner, powdered cleansers, soap, detergent or paste on any continuous cleaning surface. Also, do not use any abrasive materials, steel wool, sharp instruments or scrapers for they will damage the finish.

Avoid spillovers by using utensils that are large enough to hold food. A cookie sheet or piece of aluminum foil, just a little larger than the pan, can be placed on the rack directly below the rack holding the utensil to catch spills.

Over a period of time, wear marks may appear on the embossed rack supports. This is normal and results from sliding the racks in and out of the oven. Wear marks will not affect the cleaning action of the oven.

## STORAGE DRAWER, if equipped

The storage drawer at the bottom of the range is safe and convenient for storing metal and glass cookware. **DO NOT** store plastic, paperware, food or flammable material in this drawer. Remove drawer to clean under range.

**To remove:** Empty drawer then pull drawer out to the first stop position. Lift up front of drawer and pull to the second stop position. Grasp sides and lift up and out to remove drawer.

**To replace:** Fit the ends of the drawer glides onto the rails. Lift up drawer front and gently push in to first stop position. Lift up drawer again and continue to slide drawer to the closed position.

## LEVELING LEGS

Some floors are not level. For proper baking, your range must be level. Leveling legs are located on each corner at the base of the range. Level by turning the legs. To prevent range from accidentally tipping, range should be secured to the floor by sliding a rear leveling leg into the anti-tip bracket supplied with the range.

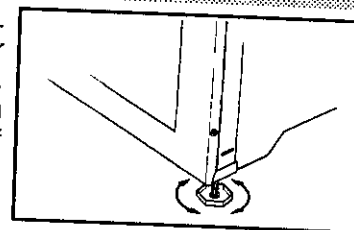

## BEFORE YOU CALL FOR SERVICE CHECK THESE POINTS

**Part or all of your electric range does not operate**

- Is the range plug loose or disconnected from the electrical outlet?
- Are any house fuses blown or circuit breakers tripped?
- Has the power supply to the home been interrupted?
- Are the oven controls properly set?

**Surface elements fail to turn on or heat the food properly.**

- Is the range plug loose or disconnect from the electrical outlet?
- If the range has coil elements, are they properly plugged into the receptacles?
- Were appropriate utensils used? (See page 6.)
- Are the surface element controls properly set?
- Is voltage to the house reduced?

**Food not baking or cooking correctly**

- Are the oven racks properly placed for baking?
- Have you used aluminum foil correctly?
- Was the oven preheated as recommended?
- Are the controls properly set?
- Is there 1 to 2 inches of space between pans and the oven walls?
- Are the range and oven racks level?
- Was good cookware/bakeware of the proper size used?
- Was the oven vent covered or blocked on the range surface?
- Are you using a tested recipe from a reliable source?
- Have you used aluminum foil correctly?

**Baking results differ from previous oven**

- Oven thermostat calibration may differ between old and new oven. The newer oven thermostat may be more accurate than the one on your previous oven. Follow a reliable recipe and review information on pages 12 and 13.

**Food does not broil correctly**

- Was the control set properly for broiling? (See page 14.)
- Was the proper rack position used? (See page 14.)
- Did you allow time for the broil element to preheat?
- Did you use the broiler pan that came with the range?
- Was aluminum foil used on the broiler insert, blocking the slits for fat drainage?
- Was the oven door opened to the broil stop position?

**Oven light does not operate**

- Is the bulb loose or burned out?
- Is the light switch in the On position?

## HOW TO OBTAIN SERVICE

**Do not attempt to service the appliance yourself unless directed to do so in this manual. Contact the dealer who sold you the appliance for service or call us. Our telephone number is found on the separate warranty sheet.**

If your appliance should require service or replacement parts, contact your dealer or authorized servicer. Be sure to have the model and serial numbers of the appliance available. See the front cover of this manual for location of these numbers. Please review the separate warranty sheet that comes with your appliance to see if the service you are requesting is covered by the warranty.

If you are not satisfied with the local response to your service requirements, write to Maytag Customer Service, P.O. Box 2370, Cleveland, TN 37320-2370. Include your name, address, phone number, the complete model and serial numbers of the appliance, the name and address of the dealer from whom you purchased the appliance, the date of purchase and details concerning your problem.

If you do not receive satisfactory service, you may contact the Major Appliance Consumer Action Program by letter. Include the information listed above.

Major Appliance Consumer Action Program  
20 North Wacker Drive  
Chicago, IL 60606

MACAP (Major Appliance Consumer Action Program) is an independent agency sponsored by three trade associations as a court of appeals on consumer complaints which have not been resolved satisfactorily within a reasonable period of time.