

This Owner's Manual is provided and hosted by [Appliance Factory Parts](#).



FRIGIDAIRE FCCW3000FS0 Owner's Manual

[Shop genuine replacement parts for FRIGIDAIRE
FCCW3000FS0](#)

FRIGIDAIRE

[Find Your FRIGIDAIRE Washer Parts - Select From 478 Models](#)

----- Manual continues below -----

Installation And Safety Instructions

Full Size Tumble Action Washer

Before beginning installation, carefully read these instructions. This will simplify the installation and ensure the washer is installed correctly and safely. Leave these instructions near the washer after installation for future reference.

NOTE: The electrical service to the washer must conform with local codes and ordinances and the latest edition of the National Electrical Code, ANSI/NFPA 70.

⚠ WARNING For your safety the information in this manual must be followed to minimize the risk of fire or explosion or to prevent property damage, personal injury or loss of life.

- Do not store or use gasoline or other flammable vapors and liquid in the vicinity of this or any other appliance.

- **WHAT TO DO IF YOU SMELL GAS**

- Do not try to light any appliance.
- Do not touch any electrical switch; do not use any phone in your building.
- Clear the room, building or area of all occupants.
- Immediately call your gas supplier from a neighbor's phone. Follow the gas suppliers instructions.
- If you cannot reach your gas supplier, call the fire department.

Installation and service must be performed by a qualified installer, service agency or the gas supplier.

Record Coin Box

Key Number _____

Key number is on key and/or coin box.

Contents

SUBJECT	PAGE
Important Safety Instructions.....	2
Pre-Installation Requirements.....	3
Electrical Requirements.....	3
Grounding Requirements.....	3
Water Supply Requirements.....	3
Drain Requirements.....	3
Rough-In Dimensions.....	3
Location Of Your Washer.....	3
Unpacking.....	3-4
Installation.....	4-5
Replacement Parts.....	5
Coin slide installation.....	5
Meter case instructions and parts lists..	6-7
Warranty.....	8

Your washer is equipped with a door safety interlock. Verify proper operation of interlock system daily, using the following procedure:

1. With the washer door open, insert the required number of coins (or the appropriate card, on machines equipped with a card-start system) and press the START button. THE WASHER MUST NOT START!
2. Close the washer door. Press the START button again to start the machine. Attempt to open the door, without exerting excessive force. THE DOOR MUST NOT OPEN!

IF THE WASHER STARTS WITH THE DOOR OPEN, OR THE DOOR CAN BE OPENED WHILE THE WASHER IS OPERATING, THE MACHINE MUST IMMEDIATELY BE TAKEN OUT OF SERVICE. DISCONNECT THE POWER CORD, AND MARK THE MACHINE "OUT OF ORDER", UNTIL THE INTERLOCK SYSTEM IS REPAIRED, AND OPERATES AS DESCRIBED ABOVE.

Note: The instructions appearing in this INSTALLATION AND SAFETY INSTRUCTIONS manual are not meant to cover every possible condition and situation that may occur. Common sense and caution must be practiced when installing, operating and maintaining any appliance.

Important Safety Instructions

Read all instructions before using this washer.

FOR YOUR SAFETY

Do not store or use gasoline or other flammable vapors or liquids in the vicinity of this or any other appliance.

⚠ WARNING Avoid fire hazard or electrical shock. Do not use an adaptor plug or extension cord or remove grounding prong from electrical power cord. Failure to follow this warning can cause serious injury, fire or death.

Grounding type wall receptacle

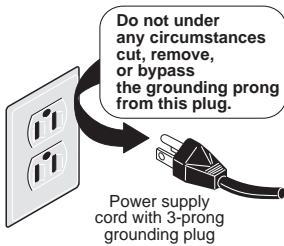

Power supply cord with 3-prong grounding plug

CORRECT
Use this way ONLY

⚠ WARNING Do not use or mix liquid chlorine bleach with other household chemicals such as toilet cleaners, rust removers, acid or products containing ammonia. These mixtures can produce dangerous fumes which can cause serious injury or death.



⚠ WARNING You can be killed or seriously injured if you don't follow these **Important Safety Instructions**:

- To reduce the risk of fire, electrical shock, or injury to persons when using this washer, comply with the basic warnings listed below.
- Failure to comply with these warnings could result in serious personal injuries.

Prevent Fire

- Do not wash items that have been previously cleaned in, soaked in, or spotted with gasoline, cleaning solvents, kerosene, cooking oils, waxes, etc. Do not store these items on or near the washer. These substances give off vapors or chemical reactions that could ignite or explode.
- Do not put oily or greasy rags or clothing on top of the washer. These substances give off vapors that could ignite the materials.
- Do not add gasoline, cleaning solvents, or other flammable or explosive substances to the wash water. These substances give off vapors that could ignite or explode.
- Under certain conditions, hydrogen gas may be produced in a hot water system that has not been used for 2 weeks or more. **HYDROGEN GAS IS EXPLOSIVE.** If the hot water system has not been used for such a period, before using the washer, turn on all hot water faucets and let the water flow from each for several minutes. This will release any accumulated hydrogen gas. Hydrogen gas is flammable; do not smoke or use an open flame during this time.
- Failure to comply with these warnings could result in fire, explosion, serious bodily injury and/or damage to the rubber or plastic parts of the washer.

Protect Children

- Do not allow children to play on or in the washer. Close supervision of children is necessary when the washer is used near children. As children grow, teach them the proper, safe use of all appliances.
- Destroy the carton, plastic bag and other packing materials after the washer is unpacked. Children might use them for play. Cartons covered with rugs, bedspreads or plastic sheets can become airtight chambers.
- Keep laundry products out of children's reach. To prevent personal injury, observe all warnings on product labels.
- Before the washer is removed from service or discarded, remove the washer lid to prevent accidental entrapment.
- Failure to comply with these warnings could result in serious personal injuries.

Prevent Injury

- Test door interlock system daily. Follow instructions on previous page.
- To prevent shock hazard and assure stability during operation, the washer must be installed and electrically grounded by a qualified service person in accordance with local codes. Refer to INSTALLATION AND SAFETY INSTRUCTIONS for detailed grounding procedures. If the washer is moved to a new location, have it checked and reinstalled by a qualified service person.
- To prevent personal injury or damage to the washer, the electrical power cord of the washer must be plugged into a properly grounded and polarized 3-prong outlet. **The third grounding prong must never be removed. Never ground the washer to a gas pipe. Do not use an extension cord or an adaptor plug.**
- Follow package directions when using laundry products. Incorrect usage can produce poisonous gas--resulting in serious injury or death.
 - **Do not** combine laundry products for use in 1 load unless specified on the label.
 - **Do not** mix chlorine bleach with ammonia or acids such as vinegar.
- To prevent serious personal injury and damage to the washer:
 - **All repairs and servicing must be performed by an authorized servicer** unless specifically recommended in this INSTALLATION AND SAFETY INSTRUCTIONS manual. Use only authorized factory parts.
 - **Do not** tamper with controls.
 - **Do not** install or store the washer where it will be exposed to the weather.
- To reduce the risk of electric shock, disconnect this appliance from the power supply before attempting any user maintenance. Turning the controls to the OFF position does not disconnect this appliance from the power supply.
- To prevent injury, do not reach into the washer while parts are moving. Before loading, unloading or adding items, push in the cycle selector knob and allow the tub to coast to a complete stop before reaching inside.
- Failure to comply with these warnings could result in serious personal injuries.
- This washer is equipped with an electrical overload protector. The motor will stop if it becomes overheated. The washer will automatically restart after a cool down period of up to 30 minutes, if the washer has not been manually turned off during this time.

SAVE THESE INSTRUCTIONS

PRE-INSTALLATION REQUIREMENTS

Tools Required for Installation:

1. 1/4 in. nut driver
2. 3/8 in. socket with ratchet.
3. 3/8 in. open end wrench.
4. 7/16 in. socket with ratchet.
5. 9/16 in. open end wrench.
6. Channel-lock adjustable pliers.
7. Carpenter's level.

ELECTRICAL REQUIREMENTS

CIRCUIT - Individual, properly polarized and grounded 15 amp. branch circuit fused with 15 amp. time delay fuse or circuit breaker.

POWER SUPPLY - 2 wire, with ground, 120 volt, single phase, 60 Hz, Alternating Current. NOTE: The use of this washer with power created by gas powered generators, solar powered generators, wind powered generators or any other generator other than the local utility company is not recommended.

OUTLET RECEPTACLE - Properly grounded 3-prong receptacle to be located so the power supply cord is accessible when the washer is in an installed position. NOTE: GFI (Ground Fault Interrupter) receptacle is not required.

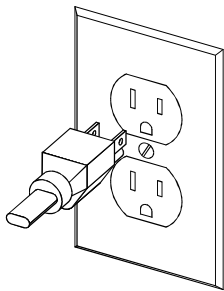

GROUNDING REQUIREMENTS

WARNING Improper connection of the equipment grounding conductor can result in a risk of electrical shock. Check with a licensed electrician if you are in doubt as to whether the appliance is properly grounded.

1. The washer **MUST** be grounded. In the event of malfunction or breakdown, grounding will reduce the risk of electrical shock by a path of least resistance for electrical current.
2. Since your washer is equipped with a power supply cord having an equipment-grounding conductor and a grounding plug, the plug **MUST** be plugged into an appropriate, copper wired receptacle that is properly installed and grounded in accordance with all local codes and ordinances or in the absence of local codes, with the National Electrical Codes, ANSI/NFPA 70 (latest edition). If in doubt, call a licensed electrician.

DO NOT cut off or alter the grounding prong on the power supply cord. In situations where a two-slot receptacle is present, it is the owner's responsibility to have a licensed electrician replace it with a **properly grounded** three prong grounding type receptacle.

WATER SUPPLY REQUIREMENTS

Hot and cold water faucets **MUST** be installed within 42 inches (107 cm) of your washer's water inlet. The faucets **MUST** be 3/4 inch (1.9 cm) garden hose type so inlet hoses can be connected. Water pressure **MUST** be between 10 and 120 pounds per square inch (maximum unbalance pressure, hot vs. cold, 10 psi.) Your water department can advise you of your water pressure.

DRAIN REQUIREMENTS

Models equipped with drain pump:

1. Drain **MUST** be capable of eliminating 17 gals (64.3 L) per minute.
2. A standpipe diameter of 1-1/4 in. (3.18 cm) minimum.
3. The standpipe height above the floor should be:

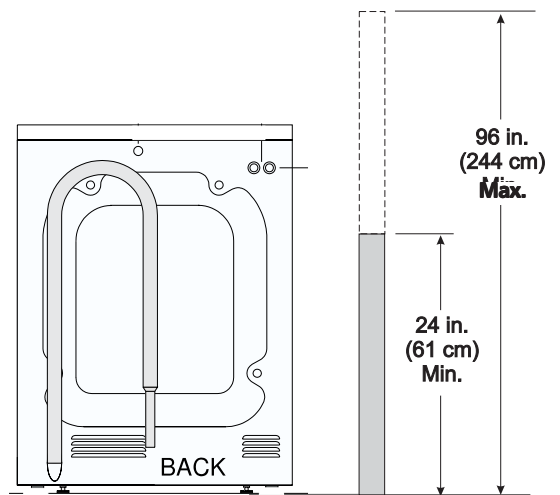

NOTE:

Drain hose attached to the washer can reach a 58 in. (147 cm) high standpipe. For higher standpipe use hose P/N 131461201, available from an authorized parts distributor. If drain is less than 24 in. (61 cm), install a siphon break kit, available at your local hardware store.

Models equipped with gravity drain:

1. Floor drain **MUST** be capable of eliminating 17 gals (64.3 L) per minute.
2. Floor drain diameter must be at least 1/2 inch larger than drain hose.

LOCATION OF YOUR WASHER

DO NOT INSTALL YOUR WASHER:

1. In an area exposed to dripping water or outside weather conditions. The ambient temperature should never be below 60 degrees F (15.6 degrees C) for proper washer operation.
2. In an area where it will come in contact with curtains or drapes.
3. In an area (garage or garage-type building) where gasoline of other flammables are kept or stored (including automobiles).
4. On carpet. Floor **MUST** be solid with a maximum slope of 1/2 in. per foot (1.27 cm per 30.5 cm). To ensure vibration or movement does not occur, reinforcement of the floor may be necessary.!

IMPORTANT MINIMUM INSTALLATION CLEARANCES

When installed in alcove: Sides, Rear, Top = 0 in (0 cm).

When installed in closet: Sides, Rear, Top = 0 in (0 cm), Front = 1 in (2.54 cm).

Closet door ventilation openings required: 2 louvers each 60 in² (387 cm²) - 3 in (7.6 cm) from top and bottom of door.

UNPACKING

1. Cut the shipping carton along the dotted line along the base of the unit.

2. While in the carton carefully lay the washer on its back side.

3. Remove the styrofoam base.

4. Carefully return the washer to an upright position and remove the carton.

5. Carefully move the washer to within 4 feet (122cm) of the final location.

6. Remove the following from the back side of the washer:
3 bolts,
3 yellow plastic spacers,
2 or 3 metal "P" clamps.

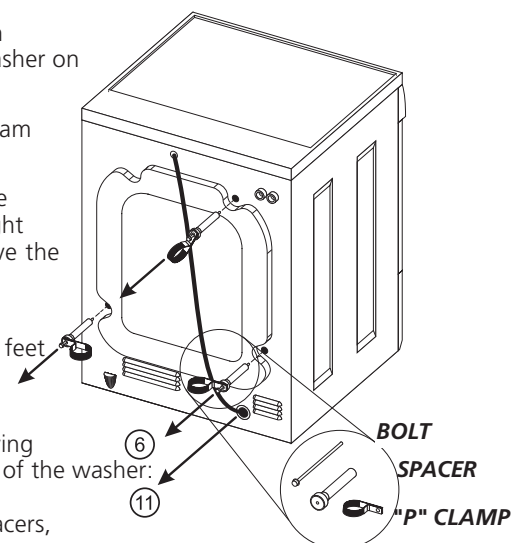

ROUGH-IN DIMENSIONS

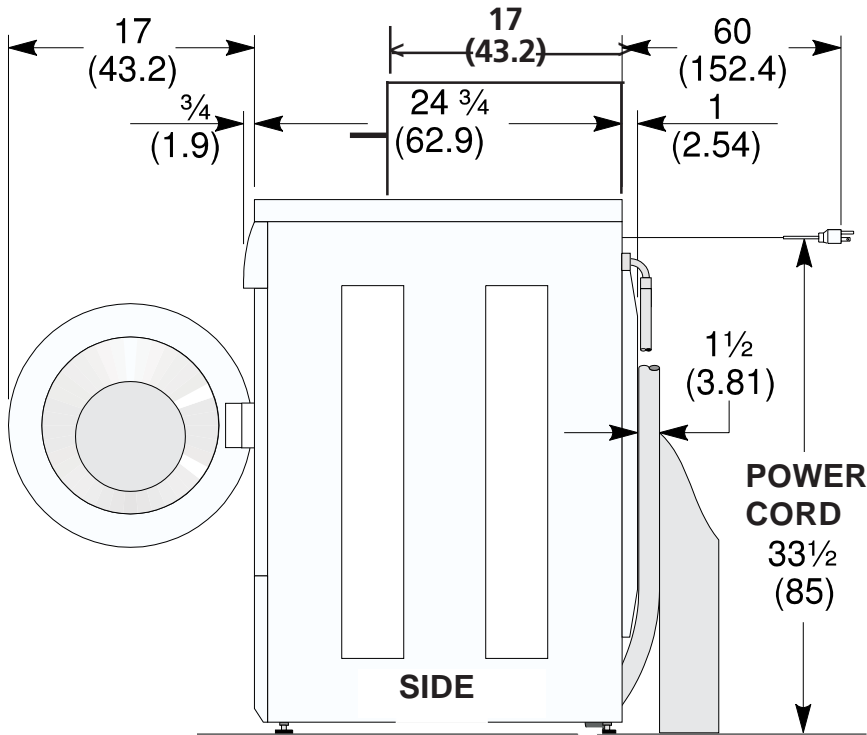

inch (cm)

7. Remove the service panel from the front of the washer.
8. Remove the 4 nuts and 6 large washers that attach the 2 yellow shipping braces to the drum and the base. Lift up on the drum and remove the braces (a yellow ribbon surrounds the items to be removed). These braces must be removed to allow the power supply cord to be released from the shipping ring.
9. Remove the large styrofoam block located under the drum. Lift up on the drum, tilt the base of the foam block inwards toward the rear of the washer until free, then pull it out.
10. Remove and discard the yellow ribbon and label from the front of the washer.
11. From the rear of the washer, carefully pull out the power supply cord through the hole in the backsheet.

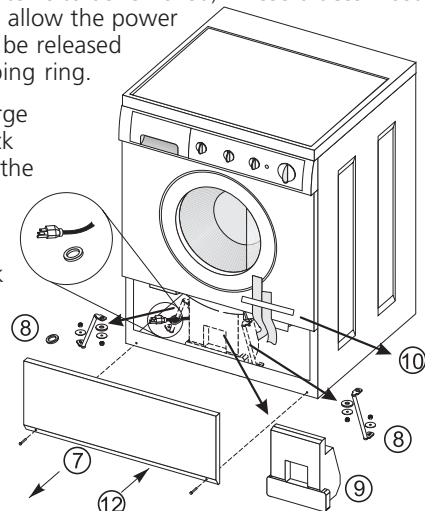

12. Replace the service panel and screws.

NOTE: If the washer is to be transported at a later date, the shipping support hardware must be reinstalled to prevent shipping damage.

INSTALLATION

1. Run some water from the hot and cold faucets to flush the water lines and remove particles that might clog up the water valve screens.
2. Remove the inlet hoses and rubber washers from the plastic bag and install the rubber washers in each end of the inlet hoses.
3. Carefully connect the inlet hose marked "HOT" to the outside "H" outlet of the water valve. Tighten by hand, then tighten another 2/3 turn with pliers. Carefully connect the other inlet hose to the inside "C" outlet of the water valve. Tighten by hand, then tighten another 2/3 turn with pliers. **Do not crossthread or over-tighten these connections.**



4. Connect the inlet hose ends to the HOT and COLD water faucets tightly by hand, then tighten another 2/3 turn with pliers. Turn the water on and check for leaks.
5. On machines equipped with drain pump, form a U shape on the end of the drain hose, with the hose pointed toward the drain.

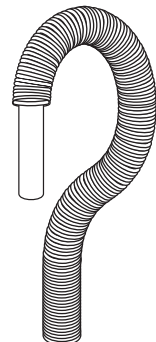

NOTE: If the drain hose is placed in a standpipe without forming a U shape, a siphoning action could occur. There must be an air gap around the drain hose. A snug hose fit can also cause a siphoning action.

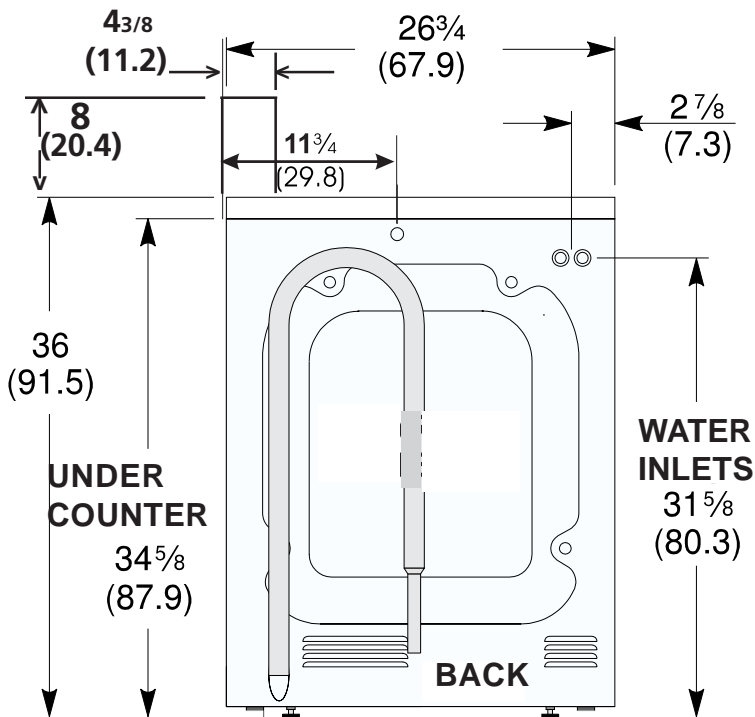

inch (cm)

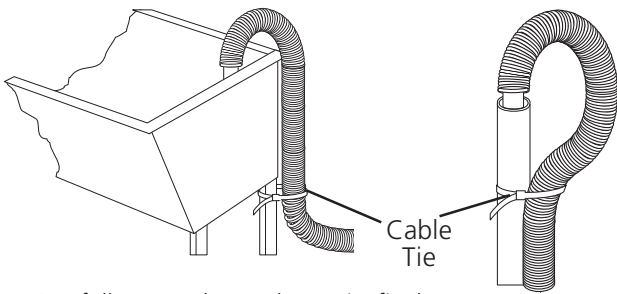

6. Carefully move the washer to its final location.

NOTE: Do not use the dispenser drawer or door to lift washer.

7. With the washer in its final position, place a level on top of the washer. Adjust the front leveling legs up or down to ensure the washer is resting solid. Turn the lock nuts on each leg up towards the base of the washer and snug with a wrench.

NOTE: Keep the leg extension at a minimum to prevent excessive vibration. The farther out the legs are extended the more the washer will vibrate. Rear leg adjustments are also accessible through the front service panel.

8. **Models equipped with drain pump:** Place the formed end of the drain hose in a laundry tub or a standpipe and secure with the cable tie provided in the enclosure package. **NOTE:** The drain pipe or floor drain, into which the drain hose is placed, **MUST** be at least 1/2 inch larger in diameter than the drain hose. This will insure that the sewer line cannot back up into the washing machine.

9. Plug the power cord into a grounded outlet.

NOTE: Check to ensure the power is off at the circuit breaker/fuse box before plugging the power cord into an outlet.

10. Turn on the power at the circuit breaker/fuse box.

11. Be sure you have read the "Important Safety Instructions" on pages 2-3 before operating this washer.

12. Run the washer through a complete cycle. Check for water leaks and proper operation.

13. Keep these instructions for future reference.

NOTE: A wiring diagram is located inside the washer on the side panel.

Install Coin Slide Mechanism

Note: If the slide mechanism has already been installed, skip this step.

Install Coin Slide

1. Remove the access panel from the top of the meter case by unlocking the service lock with the key taped to the front of the coin box.

2. Deposit coins in the coin slide and push the coin slide all the way in. Hold coin slide in extended position and insert through opening in the front of the meter case.

3. From inside the meter case, place the threaded end of the bolt through the center mounting hole in the front of the meter case.

4. While holding the bolt in place, guide the coin slide mechanism onto the threads and into the guide holes in the front of the meter case.

5. Tighten the bolt as you guide the coin slide mechanism into place.

6. Tighten the bolt using a ratchet and a 5/8-in. socket until the slide mechanism is secure and does not move.

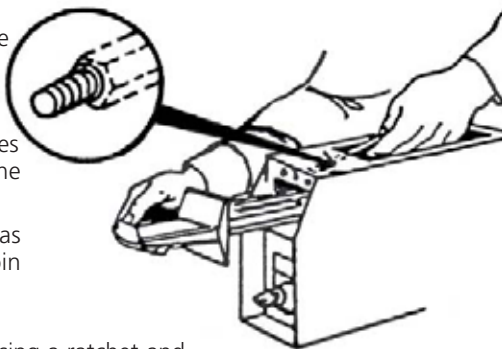

COIN BOX ADJUSTMENT

The tight fit of the money box is set at the factory. Customer may loosen fit as desired by loosening the slotted nuts. See FIG.2.

Keep A record of all coin-box key numbers.

A lost key can only be replaced by ordering the key numbers from the place where the unit was purchased. The key number is located both on the key and behind the end panel of the coin box. If the key number is not available, the lock must be drilled out to remove the coin box.

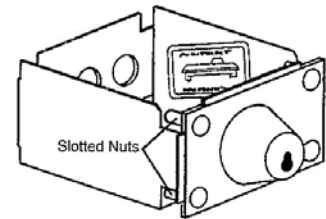

FIGURE 2

Changing Vend Price

Note: Place all screws and other items removed from coin slide assembly on a cloth so they will not get lost.

WARNING Electrical Shock hazard. Disconnect power before servicing. Replace all parts and panels before operating. Failure to do so can result in death or electrical shock.

1. Unplug washer or disconnect power.
2. Remove slide mechanism from meter case.
3. Remove slide return spring.
4. Place coin(s) in coin slot(s) and push forward all the way.
5. Remove buffer.
6. Turn coin chute upside down and install or remove required number of block-out keys. Remove keys to increase vend, add keys to lower vend.
7. Reassemble buffer.
8. Pull slide back to original position and reassemble slide return spring.
9. Set new vend price by adding or removing the appropriate block-out keys and/or dime inserts according to Table of Vend Prices.

TABLE OF VEND PRICE

VEND PRICE	COIN SLOTS							
	1	2	3	4	5	6	7	8
0	█	█	█	█	█	█	█	█
10c	□	█	█	█	█	█	█	█
25c	█	█	█	█	█	█	█	█
35c	□	█	█	█	█	█	█	█
50c	█	█	█	█	█	█	█	█
60c	□	█	█	█	█	█	█	█
75c	█	█	█	█	█	█	█	█
85c	□	█	█	█	█	█	█	█
\$1.00	█	█	█	█	█	█	█	█
\$1.10	□	█	█	█	█	█	█	█
\$1.25	█	█	█	█	█	█	█	█
\$1.35	□	█	█	█	█	█	█	█
\$1.50	█	█	█	█	█	█	█	█
\$1.60	□	█	█	█	█	█	█	█
\$1.75	█	█	█	█	█	█	█	█
\$1.85	□	█	█	█	█	█	█	█
\$2.00	█	█	█	█	█	█	█	█

NOTES:

- Black slots are closed out by block-out key. To remove block-out keys, pull straight up.
- Be sure block-out keys and/or dime inserts are seated properly and ratchet dog is in place with its spring connected. Be sure the proper coin sizing block is in place.

10. Plug in washer or reconnect power.

REPLACEMENT PARTS

If replacements parts are needed for your washer, contact the source where you purchased your washer, call 1-800-944-9044, or visit our website, www.frigidaire.com, for the Frigidaire Company Authorized Parts Distributor nearest you. For coin box parts, call 1-800-221-0982, Greenwald Industries.

WARNING Destroy the carton and plastic bags after the washer is unpacked. Children might use them for play. Cartons covered with rugs, bedspreads, or plastic sheets can become airtight chambers causing suffocation. Place all materials in a garbage container or make materials inaccessible to children.

WARNING The instructions in this manual and all other literature included with this washer are not meant to cover every possible condition and situation that may occur. Good safe practice and caution **MUST** be applied when installing, operating and maintaining any appliance.

Maximum benefits and enjoyment are achieved when all the Safety and Operating instructions are understood and practiced as a routine with your laundering tasks.

Meter Case Instructions

INSTRUCTIONS TO CHANGE THE NUMBER OF COIN SLIDE INSERTIONS TO START APPLIANCE.

1. Disconnect power from machine.
2. Turn Shaft & Cam Assembly in a clockwise direction until switch lever arm drops into cam notch (Fig. 1).
3. Lift Adjusting Tab away from cam with finger and turn Tab to desired number. Make sure Tab locks into place in new position.
4. Turn Shaft & Cam Assembly in a clockwise direction until switch lever arm is on top of Tab to assure that both mechanism switches are open (Fig. 2).
5. Reconnect power to machine.

EXAMPLE:

To change from \$1 to \$2 move tab from 1 to 2.

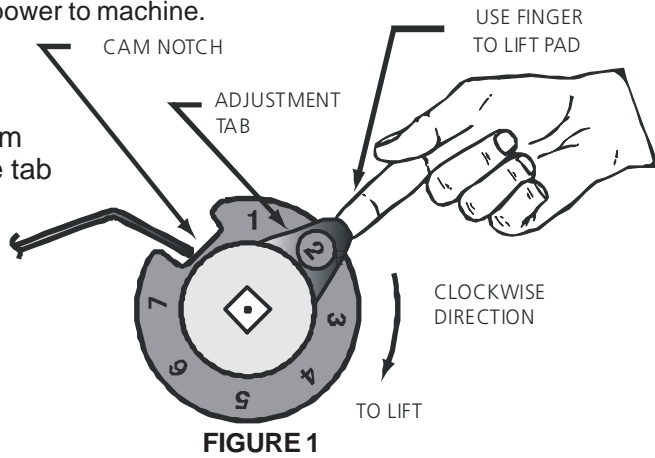

FIGURE 1

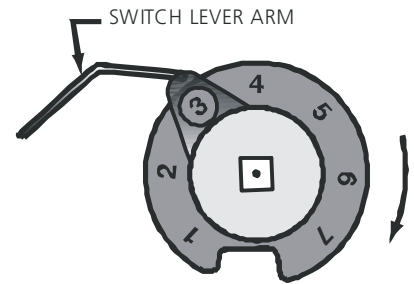
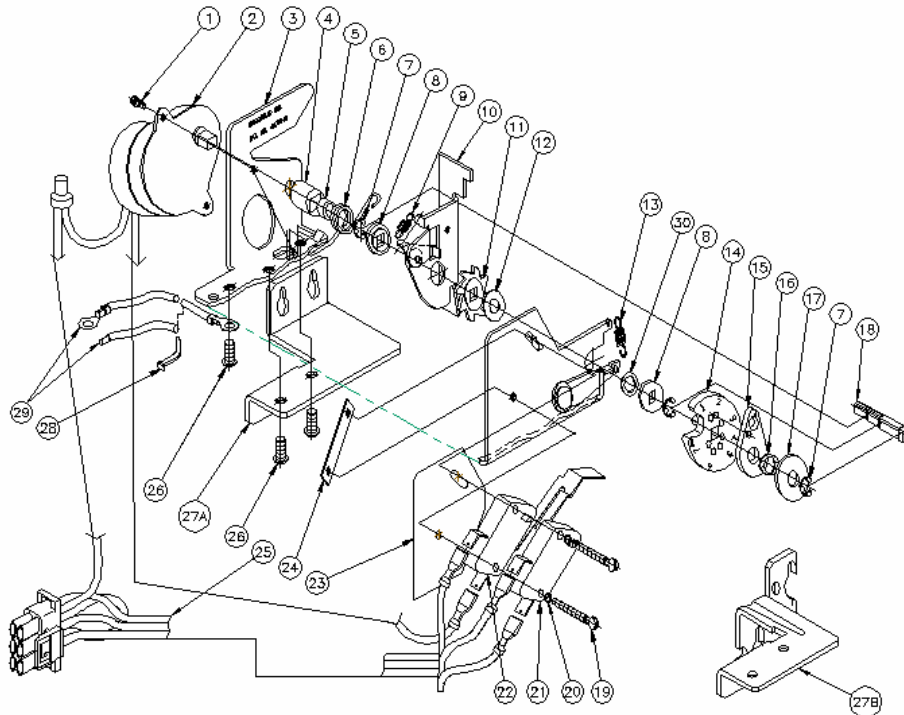

FIGURE 2

Parts List for series 7682 "Quick-Change" Start Mechanism



Item 27A: Models 76-1030-21 (115v-60Hz),
76-1030-22 (230v-60Hz)
Item 27B: Models 76-1030-11 (115v-60Hz),
76-1030-12 (230v-60Hz)

ITEM	REQ'D	PART NO	DESCRIPTION	ITEM	REQ'D	PART NO	DESCRIPTION
1	2	00-7185	#4-40 SELF-TAPPING SC.	18	1	76-2026	DRIVE SHAFT
2	1	76-6009-*	TIMER MOTOR ASS'Y	19	2	00-7458	#4-40 3/16 PAN HD SC.
3	1	76-1037	SWITCH & BRACKET SUB-ASS'Y	20	2	00-7097	#4 SPLIT LOCKWASHER
4	1	76-5014	DRIVE SELEEVE	21	1	00-6189	SNAP SWITCH
5	1	76-2033	SLEEVE	22	1	00-6190	SNAP SW. & LEVER ARM ASS'Y
6	1	00-8149	TORSION SPRING	23	1	76-5009	SWITCH INSULATOR
7	3	00-7070	RETAINING RING	24	1	76-2035	NUT PLATE
8	2	76-5013	DRIVE BUSHING	25	1	76-6000	WIRE HARNESS ASS'Y
9	1	00-8003	SPRING	26	2	02-0810-00	#8-32x5/16 SEMS SCREW
10	1	76-1036	RACHTET ARM & PAWL ASS'Y	27A	1	76-2059	MOUNTING BRACKET
11	1	76-5017	RACHET WHEEL	27B	1	76-2027	MOUNTING BRACKET
12	1	76-2003	WASHER	28	1	59-0314	CABLE TIE
13	1	59-204	SPRING	29	1	58-172-*	GROUND WIRE
14	1	76-5012	CAM	30	1	00-7558	WASHER
15	1	76-5010	ADJUSTER TAB				
16	1	00-7055	SPRING WASHER				
17	1	00-7047	WASHER				

CHANGING THE VEND PRICE ON A GREENWALD V8 COIN CHUTE

CHANGING THE PRICE OF A V8 COIN CHUTE ID# 20-3000

1. Remove slide return spring (#15).
2. Remove slide stop (#22).
3. Remove slide (#12) from chute.
4. Turn slide upside down and remove screw (#38). DO NOT REMOVE COIN RECEIVER BLOCK.
5. Turn slide and block right side up and lay on a flat surface.
6. Lift slide clear of block and set aside.
7. To change prices, add or remove blockout keys (#24) or inserts (#20).
8. Replace coin receiver block into slide and reinstall into coin chute.
9. FOR 10¢ PRICING:
 - A. Remove top housing (#3).
 - B. Install correct coin sizing block (#31) or (#36).
 - C. Reinstall top housing and return spring.
10. Install appropriate price decals (#10 & #13).

CHANGING THE PRICE OF A V8 COIN CHUTE ID# 20-3020

A. TO CHANGE 25¢ PRICING

1. Remove slide return spring (#15).
2. Place coin(s) in coin slot(s) and push slide all the way forward.
3. Remove buffer (#28).
4. Turn coin chute upside down and install or remove the required number of blockout keys (#24). Remove keys to increase vend, add keys to lower vend.
5. Reassemble buffer.
6. Pull slide back to original position and reassemble slide return spring.
7. Install appropriate price decals (#10 & #13).

B. TO CHANGE 10¢ PRICING

1. Follow Steps 1, 2, 3, 4 in A above.
2. Turn coin chute upside down. Install or remove required number of blockout keys (#24). Install or remove 10¢ insert (#20) into left hand slot of slide (right hand slot with slide turned upside down).
3. Reassemble buffer and pull slide back.
4. Remove top housing (#3).
5. Remove two screws (#2) and coin sizing block (#5). Install 10¢ coin sizing block (#31).
6. Reassemble top housing and return spring.
7. Install appropriate price decals (#10 & #13).

For additional information online use website, www.greenwaldindustries.com

V8 Parts List

	DESCRIPTION	REQ.	20-3020	20-3000
1	SCREW (METRIC)	2	00-9724	00-7924
2	SCREW (METRIC)	2	00-7938	00-7938
3	TOP HOUSING	1	20-3019	20-3002
4	SHIM	2	20-2042	-----
5	COIN SIZING BLOCK	1	20-3006	20-3006
6	GATE COVER	1	20-2043	20-2006
7	GATE	1	20-2035	20-2000
8	SLIDE STOP DOG	8	20-2011	20-2011
9	DOG SHAFT	1	20-4004	20-4000
10	DECAL, CASTING	1	00-9905	00-9905
11	BODY CASTING	1	20-3020	20-3000
12	COIN SLIDE	1	20-3021	-----
13	DECAL, SLIDE	1	00-9104	00-9104
14	CHUTE LOCATING SCREW	4	00-7483	61-55
15	SLIDE RETURN SPRING	1	00-8148	00-8148

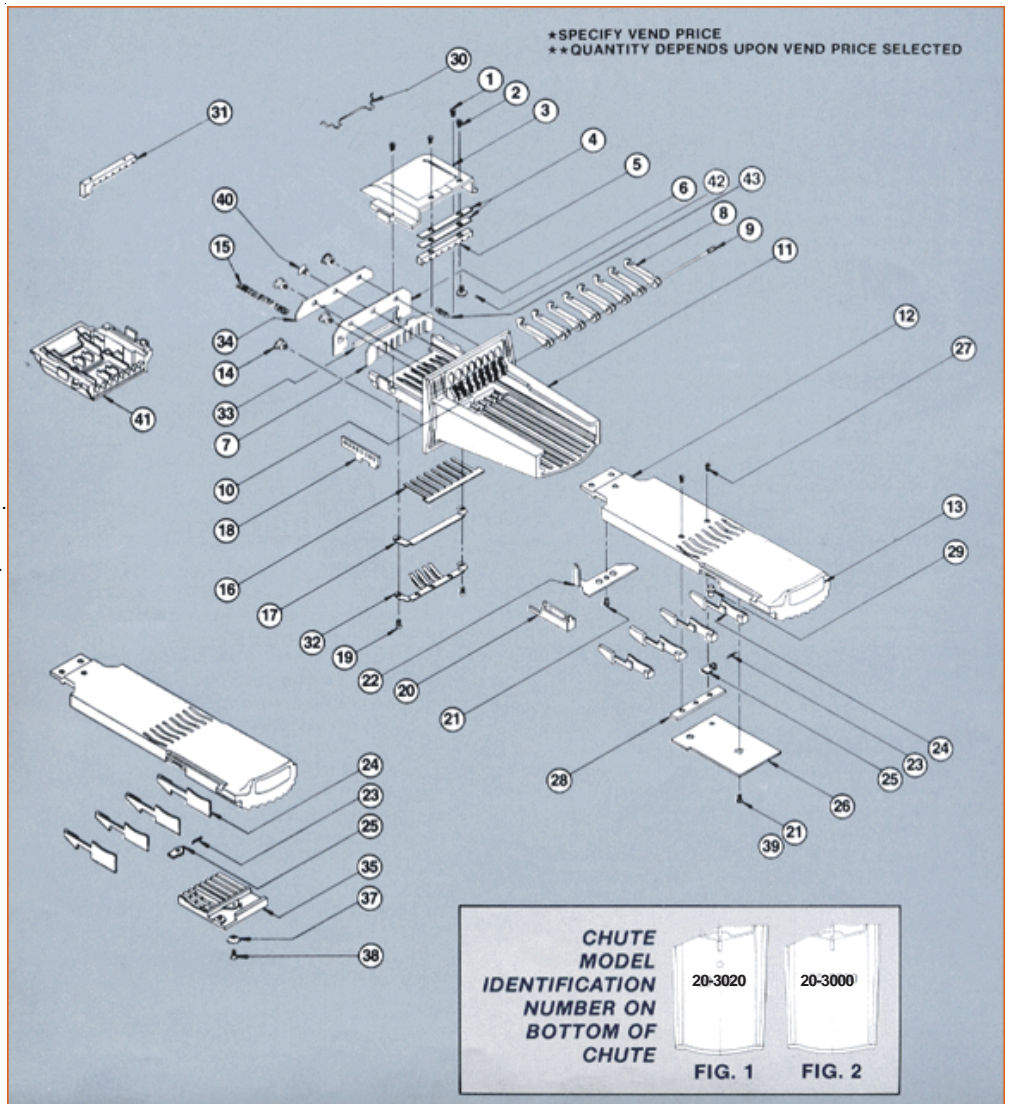

	DESCRIPTION	REQ.	20-3020	20-3000
16	SPRING	1	20-2040	20-2001
17	SPRING PROTECTOR	1	20-2038	20-2007
18	RACK	1	20-2023	20-2005
19	SCREW (METRIC)	2	00-7931	00-7931
20	10¢ INSERT varies		20-3023	20-5001
21	SCREW (METRIC)	2	00-7923	00-7929
22	SLIDE STOP	1	20-2039	20-2004
23	RATCHET DOG SPRING	1	00-8123	00-8123
24	BLOCKOUT KEY varies		20-5002	20-2010
25	SLIDE RATCHET DOG	1	20-2041	20-2008
26	STORAGE COMP. COVER		20-2037	20-2003
27	SCREW (METRIC)	2	00-7935	-----
28	BUFFER	1	20-2034	-----
29	RATCHET DOG POST	1	20-4005	-----
30	COIN RETAINER optional	Opt.	00-8168	-----

	DESCRIPTION	REQ.	20-3020	20-3000
31	COIN SIZING BLOCK varies		20-3007	20-3007
32	PRESSURE SPRING ASMY	Opt.	20-1012	20-1012
33	MAGNET	Opt.	00-9256	00-9256
34	SHIELD	Opt.	20-2045	20-2045
35	COIN RECEIVER BLOCK	1	-----	20-2003
37	LOCK WASHER	1	-----	00-7934
38	SCREW (METRIC)	1	-----	00-7933
39	SCREW (METRIC)	1	-----	00-7932
40	SCREW		00-7541	00-7541
41	TOP HOUSING ASMY		20-1103-1	20-1104-1

Commercial Appliance Warranty Information

Your appliance is covered by a **one year limited warranty**. For one year from your original date of purchase, Electrolux will pay all costs, except as set forth below, for repairing or replacing any parts of this appliance that prove to be defective in materials or workmanship when such appliance is installed, used, and maintained in accordance with the provided instructions.

Exclusions

This warranty does not cover the following:

1. All labor costs on commercial laundry products.
2. Payment acceptance devices for commercial laundry products.
3. Products with original serial numbers that have been removed, altered or cannot be readily determined.
4. Normal wear and tear and gradual deterioration.
5. Product that has been transferred from its original owner to another party or removed outside the USA or Canada.
6. Rust on the interior or exterior of the unit.
7. Products purchased "as-is".
8. Food loss due to any refrigerator or freezer failures.
9. Damage caused at any time during shipment.
10. Service calls which do not involve malfunction or defects in materials or workmanship, or for appliances used other than in accordance with the provided instructions.
11. Service calls to correct the installation of your appliance or to instruct you how to use your appliance.
12. Expenses for making the appliance accessible for servicing, such as removal of trim, cupboards, shelves, etc., which are not a part of the appliance when it is shipped from the factory.
13. Service calls to replace appliance light bulbs, air filters, water filters, other consumables, or knobs, handles, or other cosmetic parts.
14. Surcharges including, but not limited to, any after hour, weekend, or holiday service calls, tolls, ferry trip charges, or mileage expense for service calls to remote areas, including the state of Alaska.
15. Damages to the finish of appliance and/or location that are incurred during installation, including but not limited to floors, cabinets, walls, etc.
16. Damages caused by: services performed by unauthorized service companies; use of parts other than genuine Electrolux parts or parts obtained from persons other than authorized service companies; or external causes such as abuse, misuse, inadequate power supply, accidents, fires, or acts of God.
17. Labor costs after ninety (90) days from your original date of purchase incurred for product repair or replacement as provided herein for appliances operated by a concessionaire or vendor in a trailer or other motorized vehicle or at varying locations.

DISCLAIMER OF IMPLIED WARRANTIES; LIMITATION OF REMEDIES

CUSTOMER'S SOLE AND EXCLUSIVE REMEDY UNDER THIS LIMITED WARRANTY SHALL BE PRODUCT REPAIR OR REPLACEMENT AS PROVIDED HEREIN. CLAIMS BASED ON IMPLIED WARRANTIES, INCLUDING WARRANTIES OF MERCHANTABILITY OR FITNESS FOR A PARTICULAR PURPOSE, ARE LIMITED TO ONE YEAR OR THE SHORTEST PERIOD ALLOWED BY LAW, BUT NOT LESS THAN ONE YEAR. ELECTROLUX SHALL NOT BE LIABLE FOR CONSEQUENTIAL OR INCIDENTAL DAMAGES SUCH AS PROPERTY DAMAGE AND INCIDENTAL EXPENSES RESULTING FROM ANY BREACH OF THIS WRITTEN LIMITED WARRANTY OR ANY IMPLIED WARRANTY. SOME STATES AND PROVINCES DO NOT ALLOW THE EXCLUSION OR LIMITATION OF INCIDENTAL OR CONSEQUENTIAL DAMAGES, OR LIMITATIONS ON THE DURATION OF IMPLIED WARRANTIES, SO THESE LIMITATIONS OR EXCLUSIONS MAY NOT APPLY TO YOU. THIS WRITTEN WARRANTY GIVES YOU SPECIFIC LEGAL RIGHTS. YOU MAY ALSO HAVE OTHER RIGHTS THAT VARY FROM STATE TO STATE.

If You Need Service Keep your receipt, delivery slip, or some other appropriate payment record to establish the warranty period should service be required. If service is performed, it is in your best interest to obtain and keep all receipts. Service under this warranty must be obtained by contacting Electrolux at the addresses or phone numbers below.

This warranty only applies in the USA and Canada. In the USA, your appliance is warranted by **Electrolux Major Appliances North America, a division of Electrolux Home Products, Inc.** In Canada, your appliance is warranted by **Electrolux Canada Corp.** Electrolux authorizes no person to change or add to any obligations under this warranty. Obligations for service and parts under this warranty must be performed by Electrolux or an authorized service company. Product features or specifications as described or illustrated are subject to change without notice.

USA
1.866.738.1640
Electrolux Major Appliances
North America
P.O. Box 212378
Augusta, GA 30907



Canada
1.866.738.1640
Electrolux Canada Corp.
5855 Terry Fox Way
Mississauga, Ontario, Canada
L5V 3E4