

This Owner's Manual is provided and hosted by [Appliance Factory Parts](#).



# FRIGIDAIRE FCCW3000FS4 Owner's Manual

[Shop genuine replacement parts for FRIGIDAIRE  
FCCW3000FS4](#)

**FRIGIDAIRE**

[Find Your FRIGIDAIRE Washer Parts - Select From 478 Models](#)

----- Manual continues below -----

---

# Coin- Operated Commercial Tumble Action Washer

Installation Instructions and  
Use and Care Guide

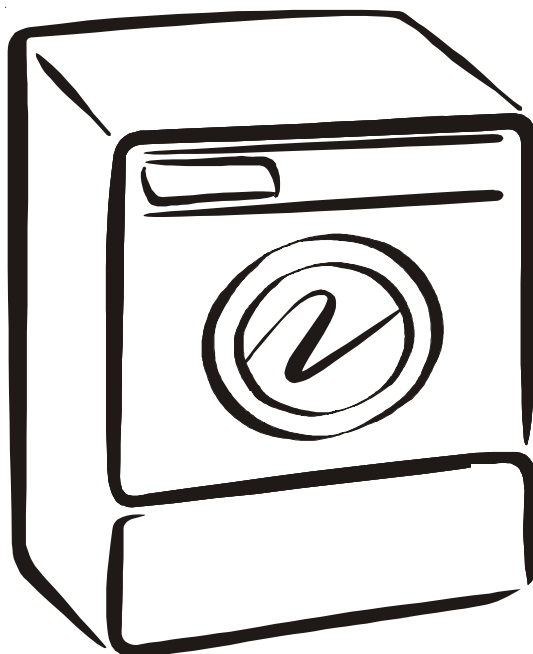

## TABLE OF CONTENTS

Important Safety Instructions.....	3	Unpacking.....	6
Pre-Installation Requirements.....	4	Installation.....	6-7
Electrical Requirements.....	4	Coin slide installation.....	7-9
Grounding Requirements.....	4	Meter case instructions.....	9
Water Supply Requirements.....	4	Replacement Parts.....	10
Drain Requirements.....	4	Parts lists.....	10-11
Location Of Your Washer.....	4	Warranty.....	12
Rough-In Dimensions.....	5		

**Before beginning installation, carefully read these instructions. This will simplify the installation and ensure the washer is installed correctly and safely. Leave these instructions near the washer after installation for future reference.**

**NOTE: The electrical service to the washer must conform with local codes and ordinances and the latest edition of the National Electrical Code, ANSI/NFPA 70.**

**NOTE:** The instructions appearing in this INSTALLATION AND SAFETY INSTRUCTIONS manual are not meant to cover every possible condition and situation that may occur. Common sense and caution must be practiced when installing, operating and maintaining any appliance.

### Product Record

For Frigidaire warranty information or to contact a Frigidaire Service Center, call **1-866-738-1640**

**If you need SERVICE or PARTS for your Frigidaire coin-operated dryer:** be ready to give the model number, serial number and date of purchase. Record below.

**Model number** \_\_\_\_\_

**Serial number** \_\_\_\_\_

**Purchase date** \_\_\_\_\_

#### Record Coin Box

**Key Number** \_\_\_\_\_

Key number is on key and/or coin box.

## WASHER SAFETY

Your safety and the safety of others is very important. We have provided many important safety messages in the Installation Instructions/Use & Care Guide and on your appliance. Always read and obey all safety messages.



This is the safety alert symbol. This symbol alerts you to hazards that can kill or hurt you or others. All safety messages will be preceded by the safety alert symbol and the word "DANGER" or "WARNING". These words mean:

**! DANGER** *You can be killed or seriously injured if you don't immediately follow instructions.*

**! WARNING** *You can be killed or seriously injured if you don't follow instructions.*

All safety messages will identify the hazard, tell you how to reduce the chance of injury, and tell you what can happen if the instructions are not followed.

#### **! WARNING**

For your safety the information in this manual must be followed to minimize the risk of fire or explosion or to prevent property damage, personal injury or loss of life.

- Do not store or use gasoline or other flammable vapors and liquid in the vicinity of this or any other appliance.

#### - **WHAT TO DO IF YOU SMELL GAS**

- Do not try to light any appliance.
- Do not touch any electrical switch; do not use any phone in your building.
- Clear the room, building or area of all occupants.
- Immediately call your gas supplier from a neighbor's phone. Follow the gas suppliers instructions.
- If you cannot reach your gas supplier, call the fire department.

Installation and service must be performed by a qualified installer, service agency or the gas supplier.

Your washer is equipped with a door safety interlock. Verify proper operation of interlock system daily, using the following procedure:

1. With the washer door open, insert the required number of coins and press the **START** button. **THE WASHER MUST NOT START!**
2. Close the washer door. Press the **START** button again to start the machine. Attempt to open the door, without exerting excessive force. **THE DOOR MUST NOT OPEN!**

**IF THE WASHER STARTS WITH THE DOOR OPEN, OR THE DOOR CAN BE OPENED WHILE THE WASHER IS OPERATING, THE MACHINE MUST IMMEDIATELY BE TAKEN OUT OF SERVICE. DISCONNECT THE POWER CORD, AND MARK THE MACHINE "OUT OF ORDER", UNTIL THE INTERLOCK SYSTEM IS REPAIRED, AND OPERATES AS DESCRIBED ABOVE.**

**⚠ WARNING** Avoid fire hazard or electrical shock. Do not use an adaptor plug or extension cord or remove grounding prong from electrical power cord. Failure to follow this warning can cause serious injury, fire or death.

Grounding type wall receptacle

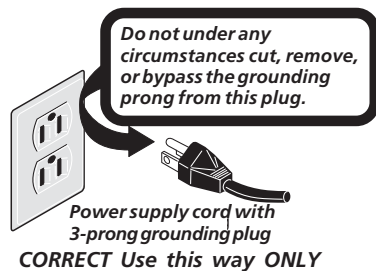

**⚠ WARNING** Do not use or mix liquid chlorine bleach with other household chemicals such as toilet cleaners, rust removers, acid or products containing ammonia. These mixtures can produce dangerous fumes which can cause serious injury or death.

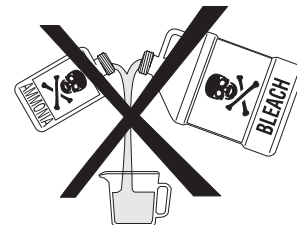

## Important Safety Instructions

Read all instructions before using this washer.

**⚠ WARNING** You can be killed or seriously injured if you don't follow these **Important Safety Instructions**:

- To reduce the risk of fire, electrical shock, or injury to persons when using this washer, comply with the basic warnings listed below.
- Failure to comply with these warnings could result in serious personal injuries.

### Prevent Fire

- Do not wash items that have been previously cleaned in, soaked in, or spotted with gasoline, cleaning solvents, kerosene, cooking oils, waxes, etc. Do not store these items on or near the washer. These substances give off vapors or chemical reactions that could ignite or explode.
- Do not put oily or greasy rags or clothing on top of the washer. These substances give off vapors that could ignite the materials.
- Do not add gasoline, cleaning solvents, or other flammable or explosive substances to the wash water. These substances give off vapors that could ignite or explode.

**FOR YOUR SAFETY** Do not store or use gasoline or other flammable vapors or liquids in the vicinity of this or any other appliance.

- Under certain conditions, hydrogen gas may be produced in a hot water system that has not been used for 2 weeks or more. **HYDROGEN GAS IS EXPLOSIVE.** If the hot water system has not been used for such a period, before using the washer, turn on all hot water faucets and let the water flow from each for several minutes. This will release any accumulated hydrogen gas. Hydrogen gas is flammable; do not smoke or use an open flame during this time.
- Failure to comply with these warnings could result in fire, explosion, serious bodily injury and/or damage to the rubber or plastic parts of the washer.

### Protect Children

- Do not allow children to play on or in the washer. Close supervision of children is necessary when the washer is used near children. As children grow, teach them the proper, safe use of all appliances.
- Destroy the carton, plastic bag and other packing materials after the washer is unpacked. Children might use them for play. Cartons covered with rugs, bedspreads or plastic sheets can become airtight chambers.
- Keep laundry products out of children's reach. To prevent personal injury, observe all warnings on product labels.
- Before the washer is removed from service or discarded, remove the washer lid to prevent accidental entrapment.
- Failure to comply with these warnings could result in serious personal injuries.

### Prevent Injury

- Test door interlock system daily. Follow instructions on previous page.
- To prevent shock hazard and assure stability during operation, the washer must be installed and electrically grounded by a qualified service person in accordance with local codes. Refer to INSTALLATION AND SAFETY INSTRUCTIONS for detailed grounding procedures. If the washer is moved to a new location, have it checked and reinstalled by a qualified service person.
- To prevent personal injury or damage to the washer, the electrical power cord of the washer must be plugged into a properly grounded and polarized 3-prong outlet. **The third grounding prong must never be removed. Never ground the washer to a gas pipe. Do not use an extension cord or an adaptor plug.**
- Follow package directions when using laundry products. Incorrect usage can produce poisonous gas--resulting in serious injury or death.
  - **Do not** combine laundry products for use in 1 load unless specified on the label.
  - **Do not** mix chlorine bleach with ammonia or acids such as vinegar.
- To prevent serious personal injury and damage to the washer:
  - **All repairs and servicing must be performed by an authorized servicer** unless specifically recommended in this INSTALLATION AND SAFETY INSTRUCTIONS manual. Use only authorized factory parts.
  - **Do not** tamper with controls.
  - **Do not** install or store the washer where it will be exposed to the weather.
- To reduce the risk of electric shock, disconnect this appliance from the power supply before attempting any user maintenance. Turning the controls to the OFF position does not disconnect this appliance from the power supply.
- To prevent injury, do not reach into the washer while parts are moving. Before loading, unloading or adding items, push in the cycle selector knob and allow the tub to coast to a complete stop before reaching inside.
- Failure to comply with these warnings could result in serious personal injuries.
- This washer is equipped with an electrical overload protector. The motor will stop if it becomes overheated. The washer will automatically restart after a cool down period of up to 30 minutes, if the washer has not been manually turned off during this time.

**SAVE THESE INSTRUCTIONS**

## PRE-INSTALLATION REQUIREMENTS

### Tools Required for Installation:

1. 1/4 in. nut driver
2. 3/8 in. socket with ratchet.
3. 3/8 in. open end wrench.
4. 7/16 in. socket with ratchet.
5. 9/16 in. open end wrench.
6. Channel-lock adjustable pliers.
7. Carpenter's level.

## ELECTRICAL REQUIREMENTS

**CIRCUIT** - Individual, properly polarized and grounded 15 amp. branch circuit fused with 15 amp. time delay fuse or circuit breaker.

**POWER SUPPLY** - 2 wire, with ground, 120 volt, single phase, 60 Hz, Alternating Current. NOTE: The use of this washer with power created by gas powered generators, solar powered generators, wind powered generators or and other generator other than the local utility company is not recommended.

**OUTLET RECEPTACLE** - Properly grounded 3-prong receptacle to be located so the power supply cord is accessible when the washer is in an installed position. NOTE: GFI (Ground Fault Interrupter) receptacle is not required.

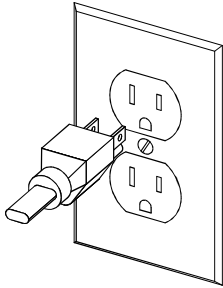

## GROUNDING REQUIREMENTS

**WARNING** Improper connection of the equipment grounding conductor can result in a risk of electrical shock. Check with a licensed electrician if you are in doubt as to whether the appliance is properly grounded.

1. The washer **MUST** be grounded. In the event of malfunction or breakdown, grounding will reduce the risk of electrical shock by a path of least resistance for electrical current.
2. Since your washer is equipped with a power supply cord having an equipment-grounding conductor and a grounding plug, the plug **MUST** be plugged into an appropriate, copper wired receptacle that is properly installed and grounded in accordance with all local codes and ordinances or in the absence of local codes, with the National Electrical Codes, ANSI/NFPA 70 (latest edition). If in doubt, call a licensed electrician.

**DO NOT** cut off or alter the grounding prong on the power supply cord. In situations where a two-slot receptacle is present, it is the owner's responsibility to have a licensed electrician replace it with a **properly grounded** three prong grounding type receptacle.

## WATER SUPPLY REQUIREMENTS

Hot and cold water faucets **MUST** be installed within 42 inches (107 cm) of your washer's water inlet. The faucets **MUST** be 3/4 inch (1.9 cm) garden hose type so inlet hoses can be connected. Water pressure **MUST** be between 10 and 120 pounds per square inch (maximum unbalance pressure, hot vs. cold, 10 psi.) Your water department can advise you of your water pressure.

## DRAIN REQUIREMENTS

Models equipped with drain pump:

1. Drain **MUST** be capable of eliminating 17 gals (64.3 L) per minute.
2. A standpipe diameter of 1-1/4 in. (3.18 cm) minimum.
3. The standpipe height above the floor should be:

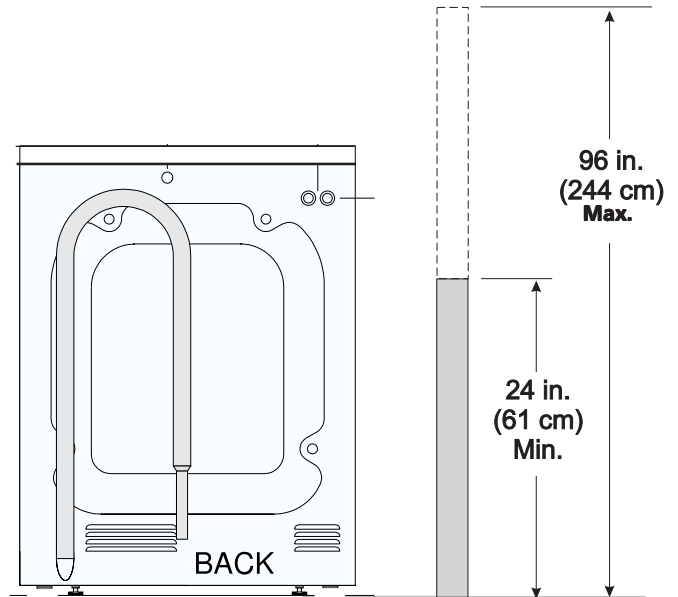

### NOTE:

Drain hose attached to the washer can reach a 58 in. (147 cm) high standpipe. For higher standpipe use hose P/N 134592701, available from an authorized parts distributor. If drain is less than 24 in. (61 cm), install a siphon break kit, available at your local hardware store.

Models equipped with gravity drain:

1. Floor drain **MUST** be capable of eliminating 17 gals (64.3 L) per minute.
2. Floor drain diameter must be at least 1/2 inch larger than drain hose.

## LOCATION OF YOUR WASHER

See rough-in dimensions on the next page (Figure 1).

### DO NOT INSTALL YOUR WASHER:

1. In an area exposed to dripping water or outside weather conditions. The ambient temperature should never be below 60 degrees F (15.6 degrees C) for proper washer operation.
2. In an area where it will come in contact with curtains or drapes.
3. In an area (garage or garage-type building) where gasoline or other flammables are kept or stored (including automobiles).
4. On carpet. Floor **MUST** be solid with a maximum slope of 1/2 in. per foot (1.27 cm per 30.5 cm). To ensure vibration or movement does not occur, reinforcement of the floor may be necessary.

### IMPORTANT MINIMUM INSTALLATION CLEARANCES

When installed in alcove: Sides, Rear, Top = 0 in (0 cm).

When installed in closet: Sides, Rear, Top = 0 in (0 cm), Front = 1 in (2.54 cm).

Closet door ventilation openings required: 2 louvers each 60 in<sup>2</sup> (387 cm<sup>2</sup>) - 3 in (7.6 cm) from top and bottom of door.

**ROUGH-IN DIMENSIONS**

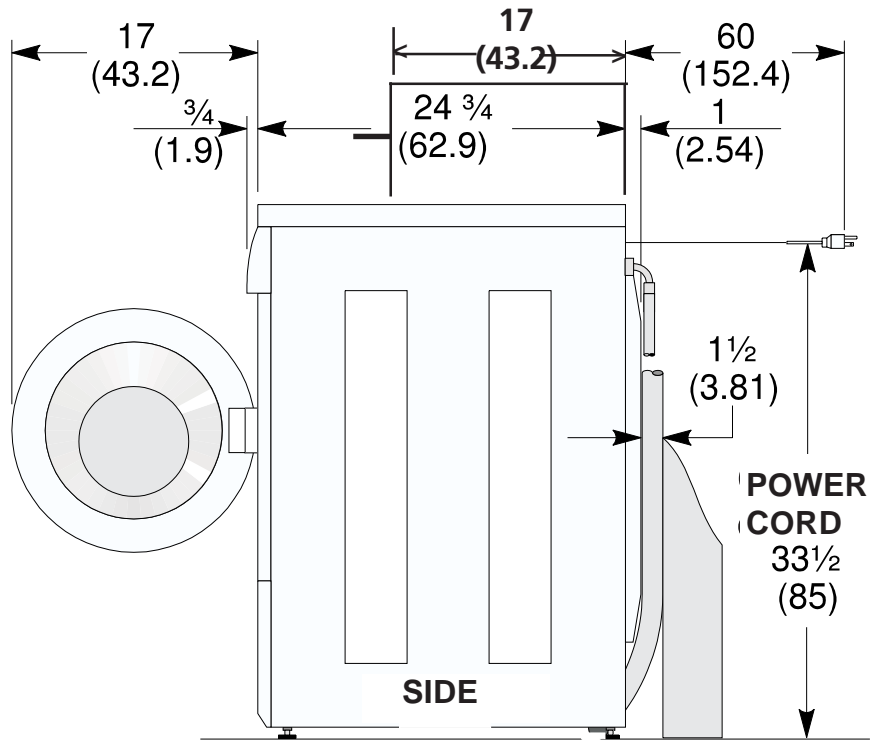

inch (cm)

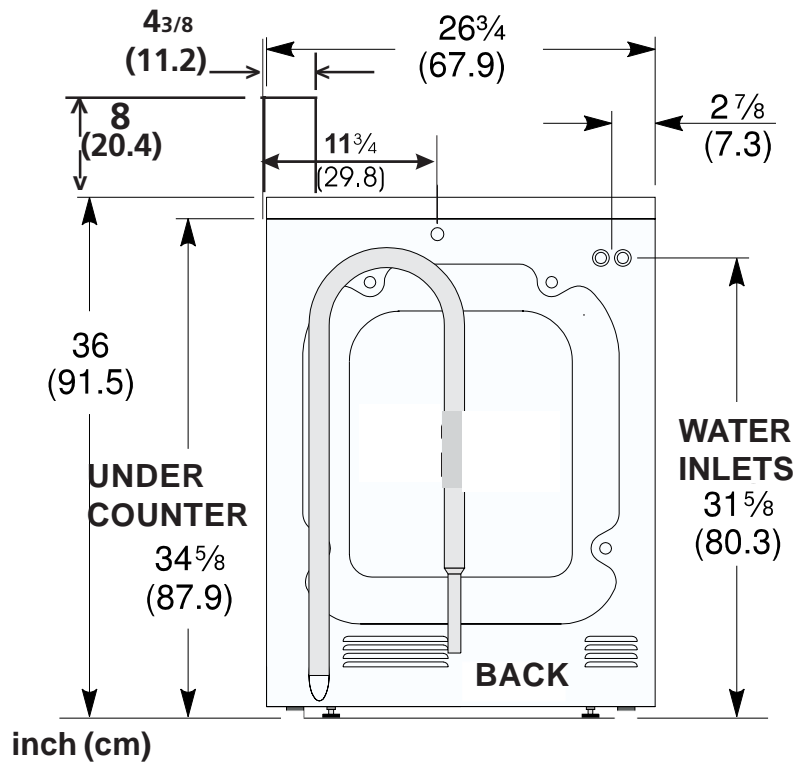

inch (cm)

**(Figure 1).**

## UNPACKING

1. Cut the shipping carton along the dotted line along the base of the unit.
2. While in the carton carefully lay the washer on its back side.
3. Remove the styrofoam base.
4. Carefully return the washer to an upright position and remove the carton.
5. Carefully move the washer to within 4 feet (122cm) of the final location.
6. Remove the following from the back side of the washer:

3 bolts,  
3 yellow plastic spacers,  
2 or 3 metal "P" clamps.

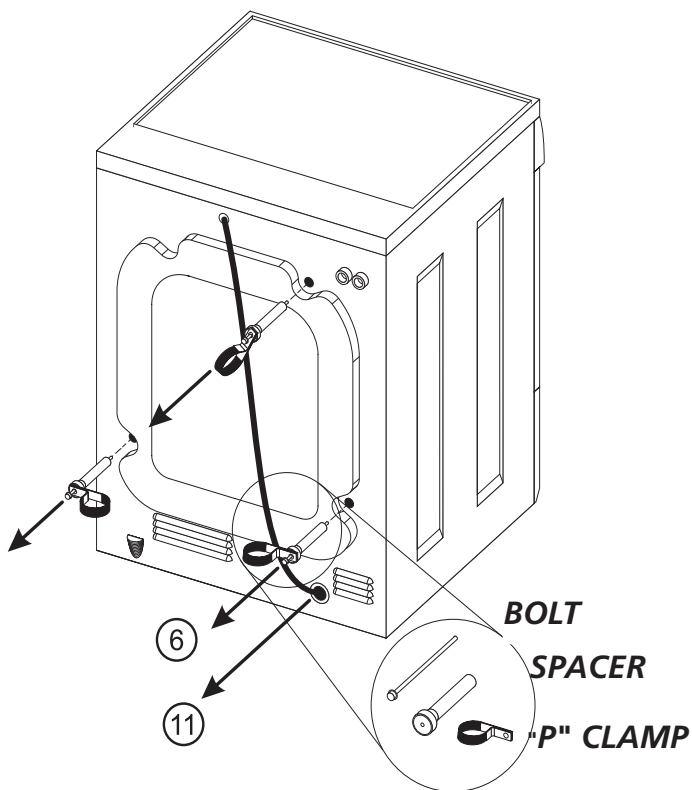

7. Remove the service panel from the front of the washer.
8. Remove the 4 nuts and 6 large washers that attach the 2 yellow shipping braces to the drum and the base. Lift up on the drum and remove the braces (a yellow ribbon surrounds the items to be removed). These braces must be removed to allow the power supply cord to be released from the shipping ring.

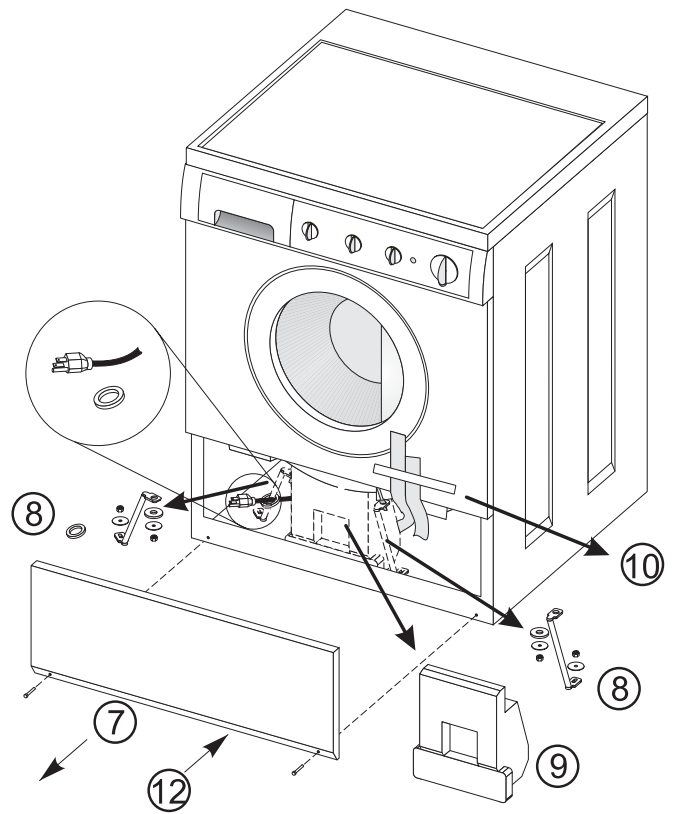

9. Remove the large styrofoam block located under the drum. Lift up on the drum, tilt the base of the foam block inwards toward the rear of the washer until free, then pull it out.
10. Remove and discard the yellow ribbon and label from the front of the washer.
11. From the rear of the washer, carefully pull out the power supply cord through the hole in the backsheet.
12. Replace the service panel and screws.

**NOTE:** If the washer is to be transported at a later date, the shipping support hardware must be reinstalled to prevent shipping damage.

## INSTALLATION

1. Run some water from the hot and cold faucets to flush the water lines and remove particles that might clog up the water valve screens.
2. Remove the inlet hoses and rubber washers from the plastic bag and install the rubber washers in each end of the inlet hoses.
3. Carefully connect the inlet hose marked "HOT" to the outside "H" outlet of the water valve. Tighten by hand, then tighten another 2/3 turn with pliers. Carefully connect the other inlet hose to the inside "C" outlet of the water valve. Tighten by hand, then tighten another 2/3 turn with pliers. **Do not crossthread or over-tighten these connections.**
4. Connect the inlet hose ends to the HOT and COLD water faucets tightly by hand, then tighten another 2/3 turn with pliers. Turn the water on and check for leaks.



- On machines equipped with drain pump, form a U shape on the end of the drain hose, with the hose pointed toward the drain.

**NOTE:** If the drain hose is placed in a standpipe without forming a U shape, a siphoning action could occur. There must be an air gap around the drain hose. A snug hose fit can also cause a siphoning action.

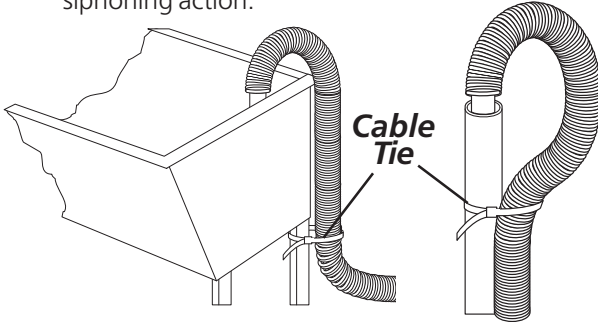
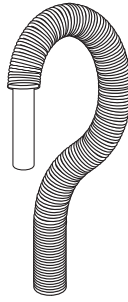

- Carefully move the washer to its final location.

**NOTE:** Do not use the dispenser drawer or door to lift washer.

Excessive noise and vibration can be prevented by properly leveling the washer.

- For free standing installation and with the washer in its final position, place a level on top of the washer. Adjust the leveling legs so the washer is level front-to-rear and side-to-side, and stable corner-to-corner.



Press down on alternate corners and sides and feel for the slightest movement. Adjust the appropriate leg so the washer is SOLID on the floor on ALL four legs. Keep the leveling leg extension at a minimum for best performance of the washer.

- For pedestal installations, See additional installation instructions included with the pedestal.

- Models equipped with drain pump:** Place the formed end of the drain hose in a laundry tub or a standpipe and secure with the cable tie provided in the enclosure package. **NOTE:** The drain pipe or floor drain, into which the drain hose is placed, **MUST** be at least 1/2 inch larger in diameter than the drain hose. This will insure that the sewer line cannot back up into the washing machine.

- Plug the power cord into a grounded outlet.

**NOTE:** Check to ensure the power is off at the circuit breaker/fuse box before plugging the power cord into an outlet.

- Turn on the power at the circuit breaker/fuse box.

- Be sure you have read the "Important Safety Instructions" before operating this washer.

- Run the washer through a complete cycle. Check for water leaks and proper operation.

- Keep these instructions for future reference.

**NOTE:** A wiring diagram is located inside the washer on the side panel.

### COIN BOX ADJUSTMENT

The tight fit of the money box is set at the factory. Customer may loosen fit as desired by loosening the slotted nuts. See FIG.2.

FIGURE 2

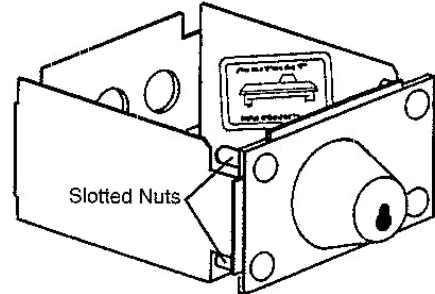

**Keep A record of all coin-box key numbers.**

A lost key can only be replaced by ordering the key numbers from the place where the unit was purchased. The key number is located both on the key and behind the end panel of the coin box. If the key number is not available, the lock must be drilled out to remove the coin box.

### Instructions for Changing Vend Price

#### TOOLS NEEDED

- Medium sized slotted screwdriver
- Small slotted Phillips screwdriver

Place all screws and other items removed from coin slide assembly on a cloth so they will not get lost.

#### STEP 1

Remove slide mechanism from meter case. (see FIGURE 1).

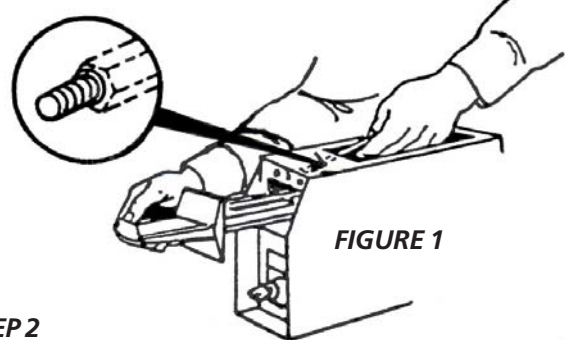

FIGURE 1

#### STEP 2

Remove the coin slide extension from coin slide by removing two mounting screws and spacers (see FIGURE 2).

(2) Mounting Screws and Spacers

FIGURE 2

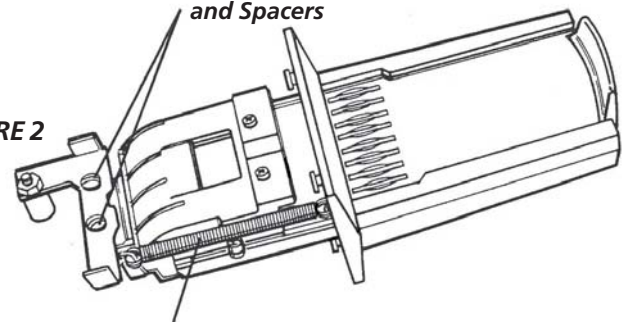

Slide Return Spring

**STEP 3**

**Remove coin slide from coin chute:**

- Unhook and remove the coin slide return spring. (see FIGURE 2).
- Turn coin slide mechanism upside down.
- Remove coin slide stop by taking out two screws to the chute bottom (see FIGURE 3).

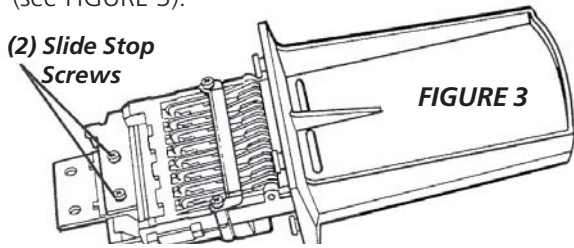

- Pull coin slide out of coin chute (see FIGURE 4).

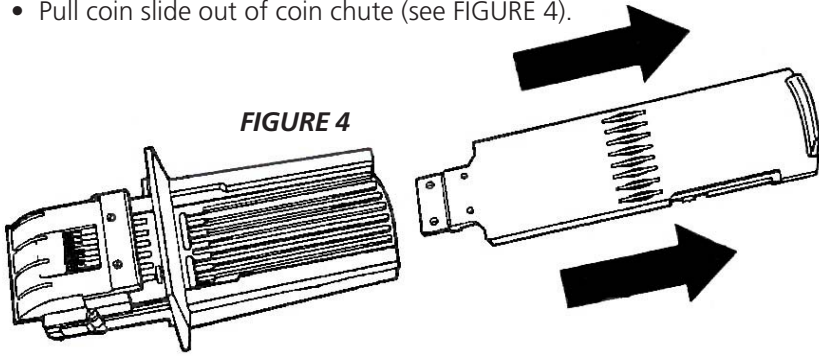

**STEP 4**

Turn coin slide upside down and remove screw that holds coin receiver block (see FIGURE 5).

**(1) Receiver Block Screw**

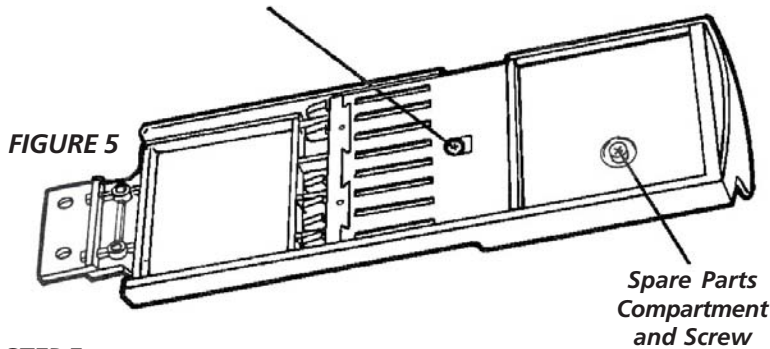

**STEP 5**

**Remove coin receiver block from coin slide (see FIGURE 6):**

- Turn coin slide right side up. Keep coin receiver block in place with your fingers.
- Carefully lift coin slide from coin receiver block. If necessary, shake coin slide gently to loosen block.

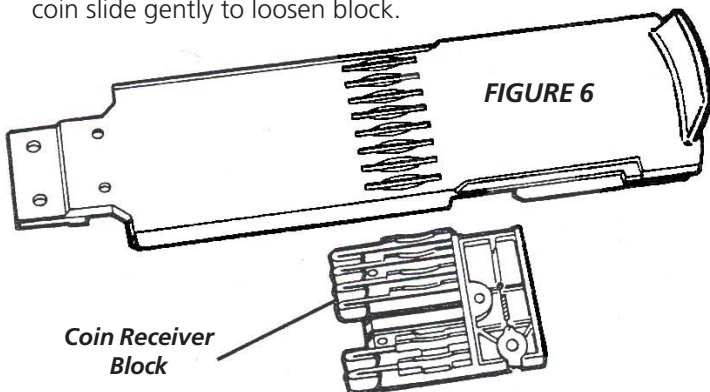

**STEP 6**

Set new vend price by adding or removing the appropriate block-out keys and/or dime inserts according to the Table of Vend Prices (see FIGURE 7).

**FIGURE 7**

**TABLE OF VEND PRICE**

VEND PRICE	COIN SLOTS							
	1	2	3	4	5	6	7	8
0	█	█	█	█	█	█	█	█
\$.10	□	█	█	█	█	█	█	█
\$.20	□	□	█	█	█	█	█	█
\$.25	█	█	□	█	█	█	█	█
\$.35	□	█	█	█	█	█	█	█
\$.45	□	□	█	█	█	█	█	█
\$.50	█	█	□	□	█	█	█	█
\$.60	□	█	█	□	█	█	█	█
\$.70	□	□	□	█	█	█	█	█
\$.75	█	█	□	□	█	█	█	█
\$.85	□	█	█	□	█	█	█	█
\$.95	□	□	□	□	█	█	█	█
\$1.00	█	█	□	□	█	█	█	█
\$1.10	□	█	█	□	□	█	█	█
\$1.20	□	□	□	□	█	█	█	█
\$1.25	█	□	□	□	█	█	█	█
\$1.35	□	█	█	□	□	█	█	█
\$1.45	□	□	□	□	□	█	█	█
\$1.50	█	□	□	□	□	█	█	█
\$1.60	□	□	□	□	□	█	█	█
\$1.70	□	□	□	□	□	□	█	█
\$1.75	█	□	□	□	□	□	█	█
\$1.85	□	□	□	□	□	□	█	█
\$2.00	□	□	□	□	□	□	□	█

**NOTE:** Black colored slots are closed off by block-out key.

To remove block-out keys, pull straight up.

**NOTE:** Be sure block-out keys and /or dime inserts are seated properly and ratchet dog is in place with its spring connected (see FIGURE 8).

Be sure the proper coin sizing block is in place.

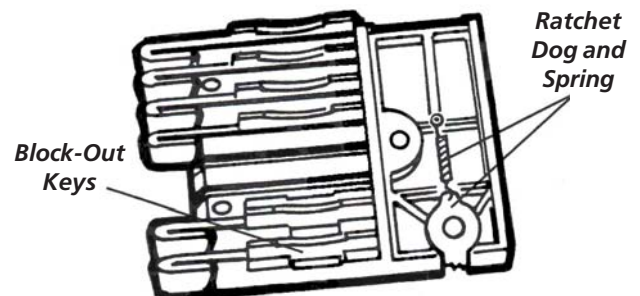

**FIGURE 8**

### Change coin sizing block:

- Remove two screws that hold upper coin chute cover. Remove cover (see FIGURE 9).

FIGURE 9

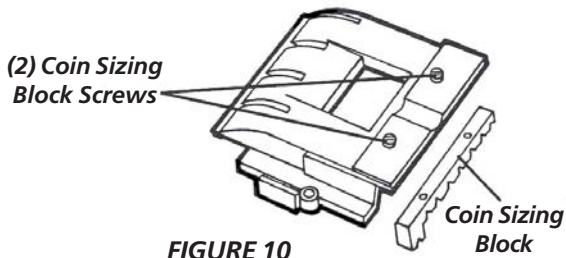
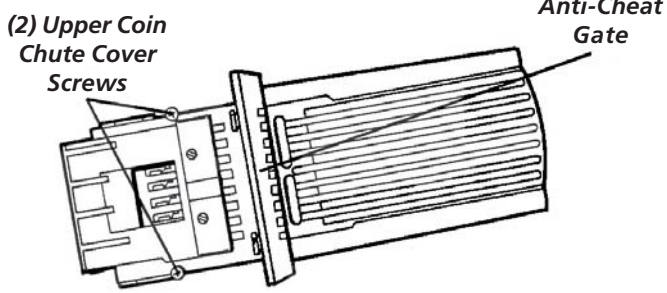

FIGURE 10

- Remove two screws that hold coin sizing block to upper coin chute cover cover (see FIGURE 10).
- Put new coin sizing block in place. Reinsert and tighten mounting screws.
- Replace coin chute cover. Reinsert and tighten screws.

### STEP 7

#### Replace coin receiver block into slide:

- Hold coin receiver right side up in the palm of one hand.
- Lower coin slide until coin receiver block fits into the coin slide cavity. CAUTION: Do not dislodge ratchet dog and spring.
- Hold coin receiver block in place with your fingers and turn slide upside down.
- Insert and tighten screw.

### STEP 8

Install slide into coin chute. Slide can only be pushed in if the anti-cheat gate in flange is pushed to the left. (see FIGURE 9).

### STEP 9

Replace coin slide stop with two screws. Replace coin slide return spring. Replace coin slide extension with two screws (be sure spacers are in place).

### STEP 10

Replace coin slide mechanism in meter case. Replace and tighten coin slide mounting bolt.

**NOTE:** It may be easier to insert coin slide mounting bolt if you remove the timer from the mounting screws temporarily.

## Meter Case Instructions

### INSTRUCTIONS TO CHANGE THE NUMBER OF COIN SLIDE INSERTIONS TO START APPLIANCE.

1. Disconnect power from machine.
2. Remove meter-case service door. (Fig.1)

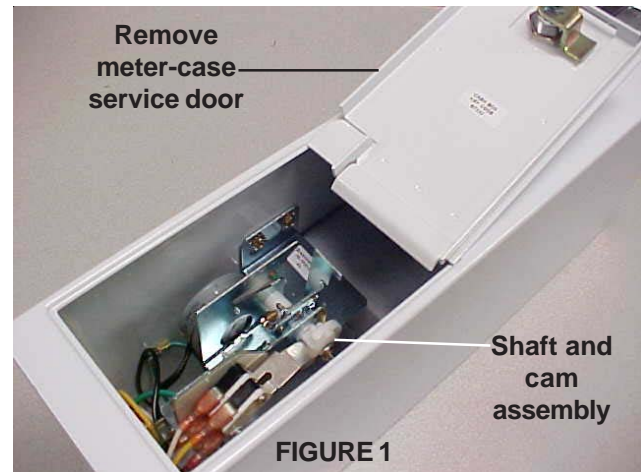

FIGURE 1

3. Turn Shaft & Cam Assembly in a clockwise direction until switch lever arm drops into cam notch (Fig. 2).
4. Lift Adjusting Tab away from cam with finger and turn Tab to desired number. Make sure Tab locks into place in new position.
5. Turn Shaft & Cam Assembly in a clockwise direction until switch lever arm is on top of Tab to assure that both mechanism switches are open (Fig. 3).
6. Replace meter-case service door and reconnect power to machine.

**EXAMPLE:** To change from \$1 to \$2 move tab from 1 to 2.

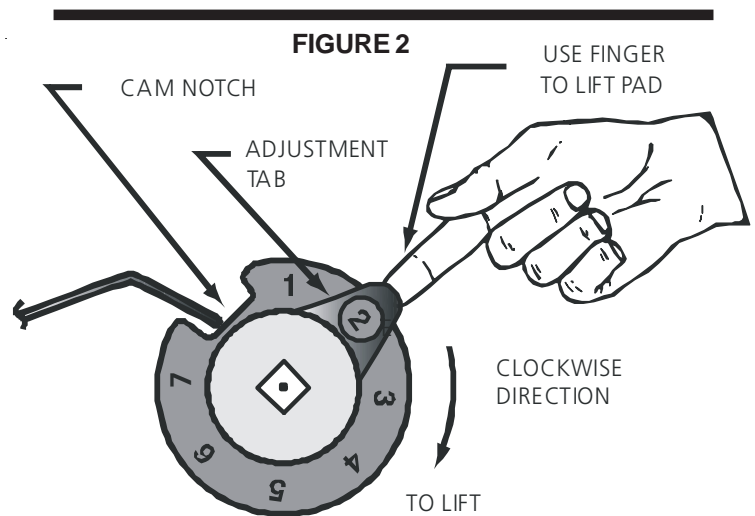

FIGURE 2

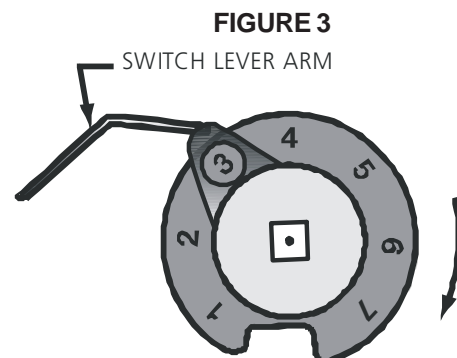

FIGURE 3

## REPLACEMENT PARTS

If replacement parts are needed for your dryer, contact the source where you purchased your dryer, or call Frigidaire at **1-866-738-1640**. For coin box parts, call 1-800-221-0982, Greenwald Industries.

**⚠ WARNING** Destroy the carton and plastic bags after the washer is unpacked. Children might use them for play. Cartons covered with rugs, bedspreads, or plastic sheets can become airtight chambers causing suffocation. Place all materials in a garbage container or make materials inaccessible to children.

**⚠ WARNING** The instructions in this manual and all other literature included with this washer are not meant to cover every possible condition and situation that may occur. Good safe practice and caution **MUST** be applied when installing, operating and maintaining any appliance.

Maximum benefits and enjoyment are achieved when all the Safety and Operating instructions are understood and practiced as a routine with your laundering tasks.

### Parts List for series 7682 "Quick-Change" Start Mechanism

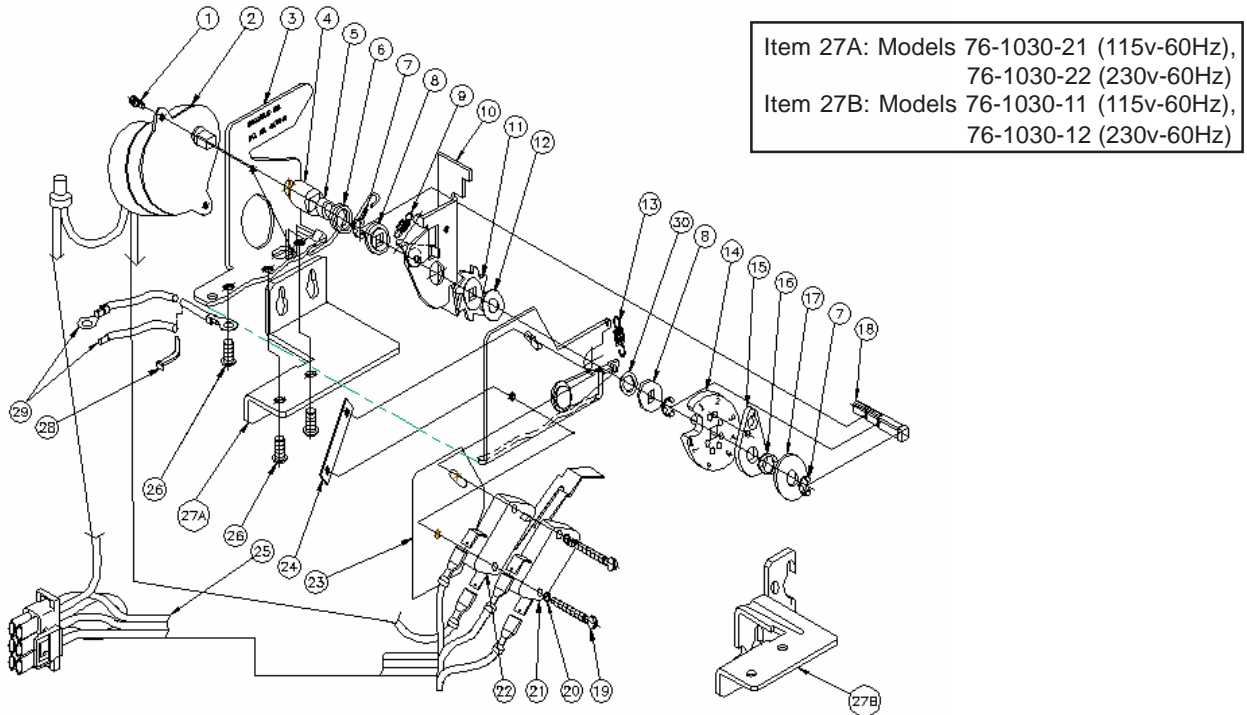

ITEM	REQ'D	PART NO	DESCRIPTION	ITEM	REQ'D	PART NO	DESCRIPTION
1	2	00-7185	#4-40 SELF-TAPPING SC.	18	1	76-2026	DRIVE SHAFT
2	1	76-6009-*	TIMER MOTOR ASS'Y	19	2	00-7458	#4-40 3/16 PAN HD SC.
3	1	76-1037	SWITCH & BRACKET SUB-ASS'Y	20	2	00-7097	#4 SPLIT LOCKWASHER
4	1	76-5014	DRIVE SELEEVE	21	1	00-6189	SNAP SWITCH
5	1	76-2033	SLEEVE	22	1	00-6190	SNAP SW. & LEVER ARM ASS'Y
6	1	00-8149	TORSION SPRING	23	1	76-5009	SWITCH INSULATOR
7	3	00-7070	RETAINING RING	24	1	76-2035	NUT PLATE
8	2	76-5013	DRIVE BUSHING	25	1	76-6000	WIRE HARNESS ASS'Y
9	1	00-8003	SPRING	26	2	02-0810-00	#8-32x5/16 SEMS SCREW
10	1	76-1036	RACHTET ARM & PAWL ASS'Y	27A	1	76-2059	MOUNTING BRACKET
11	1	76-5017	RACHTET WHEEL	27B	1	76-2027	MOUNTING BRACKET
12	1	76-2003	WASHER	28	1	59-0314	CABLE TIE
13	1	59-204	SPRING	29	1	58-172-*	GROUND WIRE
14	1	76-5012	CAM	30	1	00-7558	WASHER
15	1	76-5010	ADJUSTER TAB				
16	1	00-7055	SPRING WASHER				
17	1	00-7047	WASHER				

# V8 Coin Chute Parts List

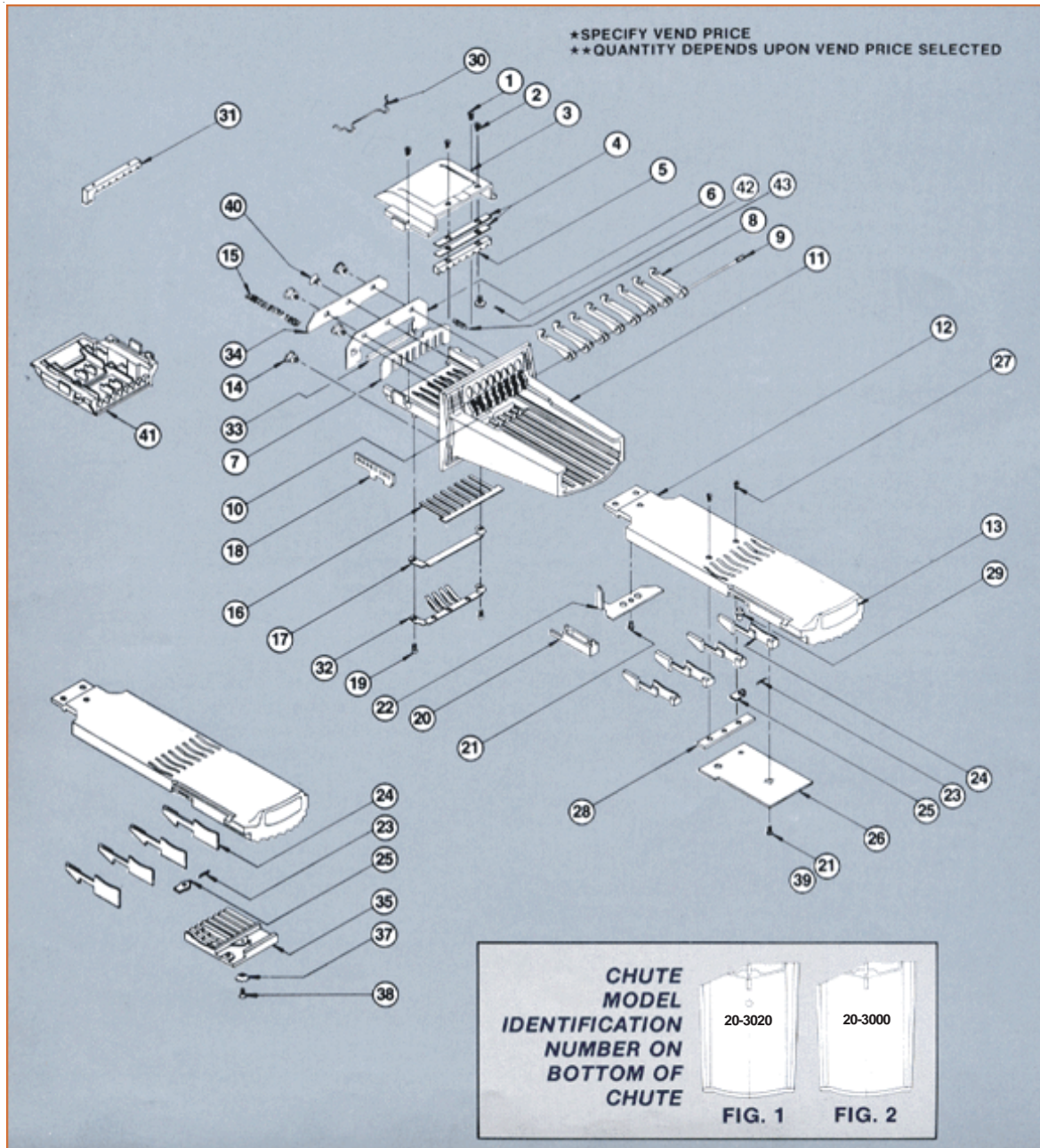

## V8 Parts List

	DESCRIPTION	REQ.	20-3020	20-3000
1	SCREW (METRIC)	2	00-9724	00-7924
2	SCREW (METRIC)	2	00-7938	00-7938
3	TOP HOUSING	1	20-3019	20-3002
4	SHIM	2	20-2042	-----
5	COIN SIZING BLOCK	1	20-3006	20-3006
6	GATE COVER	1	20-2043	20-2006
7	GATE	1	20-2035	20-2000
8	SLIDE STOP DOG	8	20-2011	20-2011
9	DOG SHAFT	1	20-4004	20-4000
10	DECAL, CASTING	1	00-9905	00-9905
11	BODY CASTING	1	20-3020	20-3000
12	COIN SLIDE	1	20-3021	-----
13	DECAL, SLIDE	1	00-9104	00-9104
14	CHUTE LOCATING SCREW	4	00-7483	61-55
15	SLIDE RETURN SPRING	1	00-8148	00-8148

	DESCRIPTION	REQ.	20-3020	20-3000
16	SPRING	1	20-2040	20-2001
17	SPRING PROTECTOR	1	20-2038	20-2007
18	RACK	1	20-2023	20-2005
19	SCREW (METRIC)	2	00-7931	00-7931
20	10¢ INSERT varies		20-3023	20-5001
21	SCREW (METRIC)	2	00-7923	00-7929
22	SLIDE STOP	1	20-2039	20-2004
23	RATCHET DOG SPRING	1	00-8123	00-8123
24	BLOCKOUT KEY varies		20-5002	20-2010
25	SLIDE RATCHET DOG	1	20-2041	20-2008
26	STORAGE COMP. COVER		20-2037	20-2003
27	SCREW (METRIC)	2	00-7935	-----
28	BUFFER	1	20-2034	-----
29	RATCHET DOG POST	1	20-4005	-----
30	COIN RETAINER optional	Opt.	00-8168	-----

	DESCRIPTION	REQ.	20-3020	20-3000
31	COIN SIZING BLOCK varies		20-3007	20-3007
32	PRESSURE SPRING ASMY	Opt.	20-1012	20-1012
33	MAGNET	Opt.	00-9256	00-9256
34	SHIELD	Opt.	20-2045	20-2045
35	COIN RECEIVER BLOCK	1	-----	20-2003
37	LOCK WASHER	1	-----	00-7934
38	SCREW (METRIC)	1	-----	00-7933
39	SCREW (METRIC)	1	-----	00-7932
40	SCREW		00-7541	00-7541
41	TOP HOUSING ASMY		20-1103-1	20-1104-1

## NEW VEND PRICE

### Order Form

To change vend price, detach and mail the lower portion to:

**Customer Service Department  
Greenwald Industries Inc.  
212 Middlesex Ave.  
Chester, CT 06412**

Order required parts using this tear-off. Block-out keys will be shipped to you at no charge. Follow product information instructions.

Quantity \_\_\_\_\_

Existing Vend Price \_\_\_\_\_

Name \_\_\_\_\_

Company \_\_\_\_\_

Address \_\_\_\_\_

City \_\_\_\_\_

State/Zip \_\_\_\_\_

Daytime phone \_\_\_\_\_

Purchase date \_\_\_\_\_

The coin chute has been pre-set at the factory.

#### When increasing in \$.25 pricing

Follow product information instructions; no extra parts required.

#### When decreasing in \$.25 pricing - or - changing to

#### \$.10 pricing.

(Coin sizing block required; see "Changing Vend Price" section.)

## COMMERCIAL APPLIANCE WARRANTY INFORMATION

Your appliance is covered by a **one year limited warranty**. For one year from your original date of purchase, Electrolux will pay all costs, except as set forth below, for repairing or replacing any parts of this appliance that prove to be defective in materials or workmanship when such appliance is installed, used, and maintained in accordance with the provided instructions.

### Exclusions

#### This warranty does not cover the following:

1. Payment acceptance devices for commercial laundry products.
2. Products with original serial numbers that have been removed, altered or cannot be readily determined.
3. Normal wear and tear and gradual deterioration.
4. Product that has been transferred from its original owner to another party or removed outside the USA or Canada.
5. Rust on the interior or exterior of the unit.
6. Products purchased "as-is".
7. Food loss due to any refrigerator or freezer failures.
8. Damage caused at any time during shipment.
9. Service calls which do not involve malfunction or defects in materials or workmanship, or for appliances used other than in accordance with the provided instructions.
10. Service calls to correct the installation of your appliance or to instruct you how to use your appliance.
11. Expenses for making the appliance accessible for servicing, such as removal of trim, cupboards, shelves, etc., which are not a part of the appliance when it is shipped from the factory.
12. Service calls to replace appliance light bulbs, air filters, water filters, other consumables, or knobs, handles, or other cosmetic parts.
13. Surcharges including, but not limited to, any after hour, weekend, or holiday service calls, tolls, ferry trip charges, or mileage expense for service calls to remote areas, including the state of Alaska.
14. Damages to the finish of appliance and/or location that are incurred during installation, including but not limited to floors, cabinets, walls, etc.
15. Damages caused by: services performed by unauthorized service companies; use of parts other than genuine Electrolux parts or parts obtained from persons other than authorized service companies; or external causes such as abuse, misuse, inadequate power supply, accidents, fires, or acts of God.
16. Labor costs after ninety (90) days from your original date of purchase incurred for product repair or replacement as provided herein for appliances operated by a concessionaire or vendor in a trailer or other motorized vehicle or at varying locations.

### DISCLAIMER OF IMPLIED WARRANTIES; LIMITATION OF REMEDIES

CUSTOMER'S SOLE AND EXCLUSIVE REMEDY UNDER THIS LIMITED WARRANTY SHALL BE PRODUCT REPAIR OR REPLACEMENT AS PROVIDED HEREIN. CLAIMS BASED ON IMPLIED WARRANTIES, INCLUDING WARRANTIES OF MERCHANTABILITY OR FITNESS FOR A PARTICULAR PURPOSE, ARE LIMITED TO ONE YEAR OR THE SHORTEST PERIOD ALLOWED BY LAW, BUT NOT LESS THAN ONE YEAR. ELECTROLUX SHALL NOT BE LIABLE FOR CONSEQUENTIAL OR INCIDENTAL DAMAGES SUCH AS PROPERTY DAMAGE AND INCIDENTAL EXPENSES RESULTING FROM ANY BREACH OF THIS WRITTEN LIMITED WARRANTY OR ANY IMPLIED WARRANTY. SOME STATES AND PROVINCES DO NOT ALLOW THE EXCLUSION OR LIMITATION OF INCIDENTAL OR CONSEQUENTIAL DAMAGES, OR LIMITATIONS ON THE DURATION OF IMPLIED WARRANTIES, SO THESE LIMITATIONS OR EXCLUSIONS MAY NOT APPLY TO YOU. THIS WRITTEN WARRANTY GIVES YOU SPECIFIC LEGAL RIGHTS. YOU MAY ALSO HAVE OTHER RIGHTS THAT VARY FROM STATE TO STATE.

### If You Need Service

Keep your receipt, delivery slip, or some other appropriate payment record to establish the warranty period should service be required. If service is performed, it is in your best interest to obtain and keep all receipts. Service under this warranty must be obtained by contacting Electrolux at the addresses or phone numbers below.

Your appliance is covered by a one year limited warranty. For one year from your original date of purchase, Electrolux will pay all costs, except as set forth below, for repairing or replacing any parts of this appliance that prove to be defective in materials or workmanship when such appliance is installed, used, and maintained in accordance with the provided instructions. This warranty only applies in the USA and Canada. In the USA, your appliance is warranted by **Electrolux Major Appliances North America, a division of Electrolux Home Products, Inc.** In Canada, your appliance is warranted by **Electrolux Canada Corp.** Electrolux authorizes no person to change or add to any obligations under this warranty. Obligations for service and parts under this warranty must be performed by Electrolux or an authorized service company. Product features or specifications as described or illustrated are subject to change without notice.

**USA 1.866.738.1640**

Electrolux Major Appliances North America  
P.O. Box 212378 August, GA 30907

**Canada 1.866.738.1640**

Electrolux Canada Corp.  
5855 Terry Fox Way  
Mississauga, Ontario, Canada L5V 3E4

