

Product features may vary from the picture above.

Please read this manual and save it with your original sales receipt.

Tools needed for assembly: Phillips Screwdriver, Hammer, Safety Scissors, Slotted Screwdriver and Adjustable Wrench (no tools included).

Use only with a Power Wheels® 12 Volt Rechargeable Battery and a Power Wheels® 12 Volt Charger (both included).

Sound Box requires three “AA” (LR6) **alkaline** batteries (batteries not included) for operation.

 Harley-Davidson is a registered trademark and the motorcycle sound is a trademark of H-D Michigan, Inc. used under license. Fisher-Price, Power Wheels by Fisher-Price and Power Lock are U.S. trademarks of Mattel, Inc.

www.powerwheels.com



Owner's Manual with Assembly Instructions

For Models B3160 and B9784

Table of Contents

A	Important Information	2
B	Warnings and Cautions	3
C	Parts	4
D	Parts Diagram	8
E	Battery Charging	9
F	Assembly	11
G	Label Decoration	26
H	Battery Installation	30
I	Battery Care and Disposal	31
J	Caring For Your Vehicle	31
K	Rules For Safe Driving	32
L	How to Operate Your Vehicle	33
M	FCC Note (United States Only)	34
N	Statement of Limited Warranty	34
O	Problems and Solutions Guide	35

A

Important Information

- Your new vehicle requires adult assembly. Please set aside at least 90 minutes for assembly.
- You must charge your battery for 18 - 30 hours **before you use your vehicle for the first time**. We recommend that you start charging your battery before beginning assembly. Please see Battery Charging beginning on page 9 for detailed instructions.
- Read this manual carefully for important safety information and operating instructions before using your vehicle. Keep this manual for future reference as it contains important information.
- This vehicle is designed for use on: grass, asphalt and other hard surfaces; on generally level terrain; and by children 3 years of age and older.
- Make sure children know and follow these rules for safe driving and riding:
 - always sit on the seat.
 - always wear shoes.
 - only 1 (one) rider at a time.
- Please note that the front wheel of the vehicle can lift slightly off the ground during use, especially if the vehicle is driven forward in high speed from a stopped position. This is a normal occurrence and is not cause for alarm. The vehicle will not tip. The rear wheel is designed to act as a stabilizer by restricting front wheel lift, preventing the vehicle from tipping. To prevent front wheel lift, teach your child to start the vehicle in low speed and shift to high speed only when already moving forward.
- Use this vehicle **ONLY** outdoors. Most interior flooring can be damaged by riding this vehicle indoors. Fisher-Price® will not be responsible for damage to floor if the vehicle is used indoors.
- For safety reasons, your vehicle has been pre-set so that it will operate at low speed. Note that the power boost button on the handlebar will not operate in the pre-set, low speed mode. **You must connect the high speed hook-up to allow operation of the vehicle at high speed when pressing the power boost button on the handlebar.** Please see page 33 for detailed instructions.
- To prevent damaging the motors and gears, teach your child to stop the vehicle before switching direction. Do not tow anything behind the vehicle or overload it. Do not exceed the maximum weight capacity of 65 lb (29.5 kg).
- If you have any questions about your Power Wheels® vehicle, please call our toll-free service lines at **1-800-348-0751** from 8 AM to 6 PM (EST) Monday through Friday. Trained customer service representatives are available to take your call in English or French. Habla Español? Si usted tiene alguna pregunta ó necesita asistencia llame gratis **1-800-348-0755** para los Estados Unidos. Tenemos representantes que hablan español para atender su llamada.
- For your convenience, Power Wheels® maintains an **independently owned and operated** Authorized Service Center Network with more than 400 authorized service centers nationwide. The authorized service centers will repair or replace parts under warranty at no extra charge, and can perform non-warranty repairs for a minimal charge. To find the authorized service center nearest to you, visit us on-line at **www.powerwheels.com** or call **1-800-348-0751**.
- If you would like to register your vehicle, please visit us on-line at **www.powerwheels.com**.

B

Warnings and Cautions

ELECTRICAL HAZARD

WARNING

- Battery can fall out and injure a child if vehicle tips over. Always use battery clamp.
- **PREVENT FIRE**
 - Never modify the electrical system. Alterations could cause a fire resulting in serious injury and could also ruin the electrical system.
 - Use of the wrong type battery or charger could cause a fire or explosion resulting in serious injury.
 - Use of Power Wheels® components in products other than Power Wheels® vehicles could cause overheating, fire or explosion.
- The battery must be handled by adults only. The battery is heavy and contains sulfuric acid (electrolyte). Dropping the battery could result in serious injury.
- Never allow children to charge the battery. Battery charging must be done by adults only. A child could be injured by the electricity involved in charging the battery.
- Read the safety instructions on the battery.
- Examine the battery, charger and their connectors for excessive wear or damage each time you charge the battery. If damage or excessive wear is detected, do not use the charger or the battery until you have replaced the worn or damaged part.
- **HOT** motors. Handle carefully.

RIDING HAZARD

WARNING

- **Prevent Injuries and Deaths**
 - Direct Adult Supervision Required
 - Keep Children Within Safe Riding Areas.
These areas must be:
 - away from swimming pools and other bodies of water to prevent drownings
 - generally level to prevent tipovers
 - away from steps, driveways, cars, roads and alleys.

CAUTION

- In the unassembled state, this package contains small parts. Adult assembly is required.
- Use the charger in dry locations only.

C

Parts

- If you experience a problem with this product, or are missing a part, please call us at **1-800-348-0751**, rather than return this product to the store.
- Please identify all parts before assembly and save all packaging material until assembly is complete to ensure that no parts are discarded.
- Metal parts have been coated with a lubricant to protect them during shipment. Wipe all metal parts with a paper towel to remove any excess lubricant.

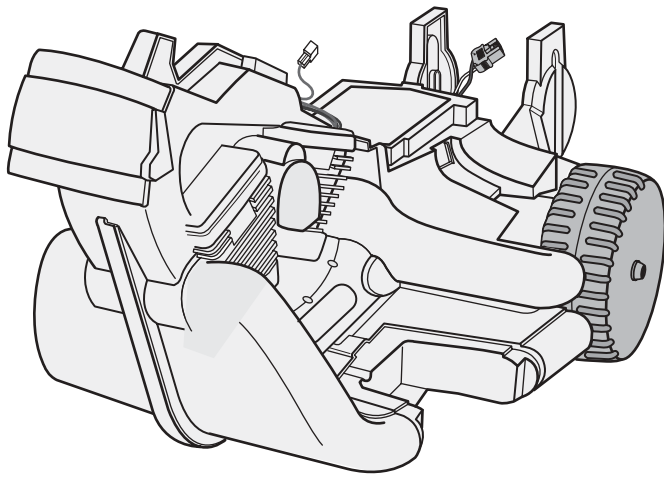

Vehicle Frame

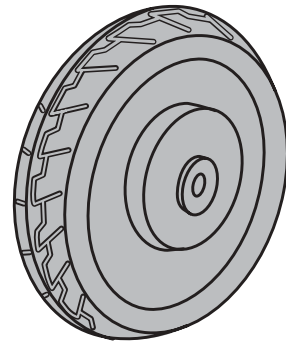

Rear Wheel

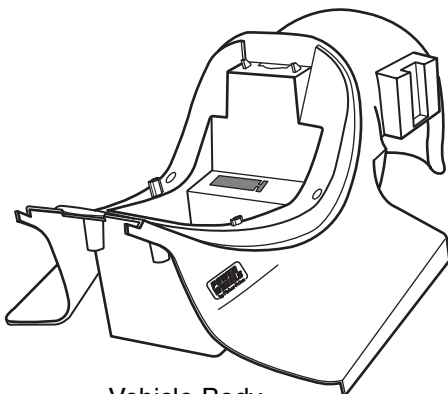

Vehicle Body

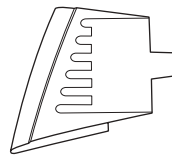

Left Footboard

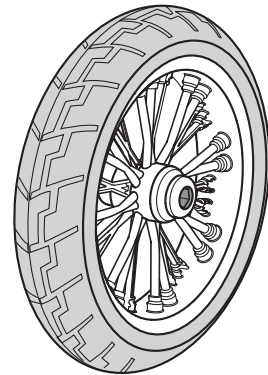

Front Wheel

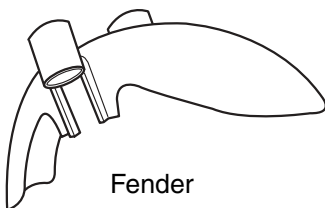

Fender

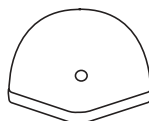

Steering Stop



Steering Bushing - 2

Parts

Exhaust Pipe Set

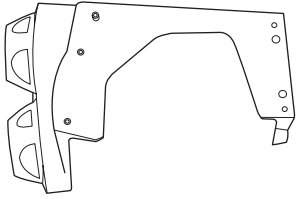

Left - Inner Half

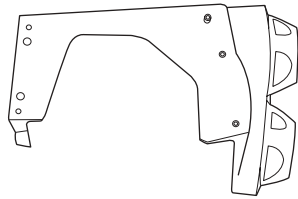

Right - Inner Half

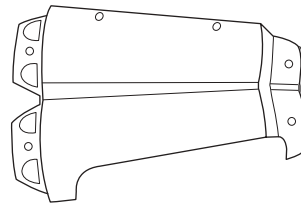

Right - Outer Half

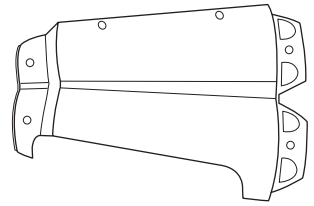

Left - Outer Half

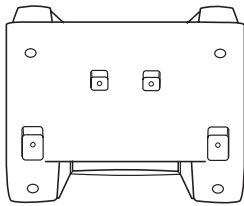

Front Fork

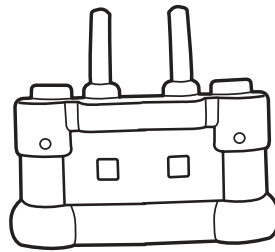

Front Fork Cover

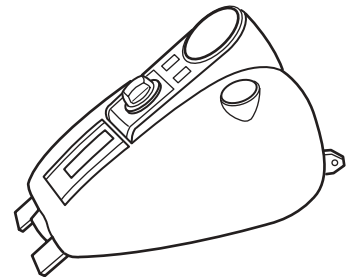

Tank

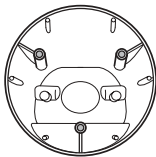

Headlight Housing

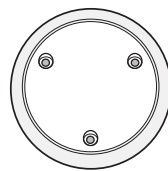

Headlight Lens

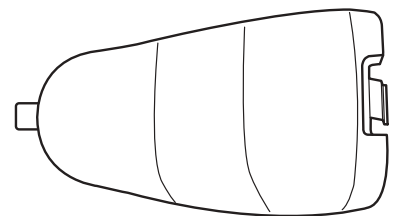

Seat

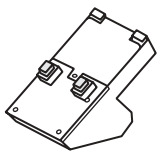

Sound Box

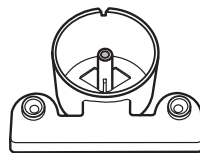

Tachometer Housing

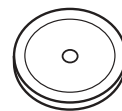

Tachometer Cover

Parts

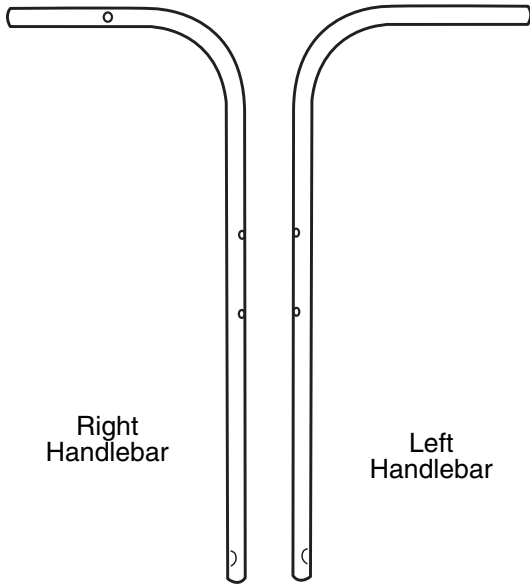

Left Shock Set

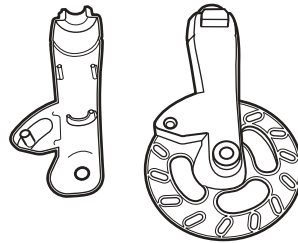

Outer

Inner

Right Shock Set

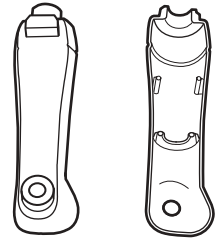

Inner

Outer

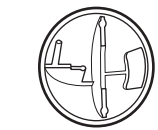

Signal Lens - 2

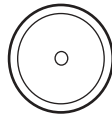

Signal Housing - 2

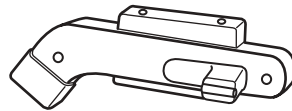

Left Strut

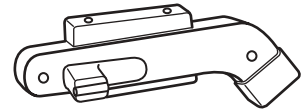

Right Strut



Switch Cover

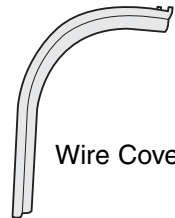

Wire Cover

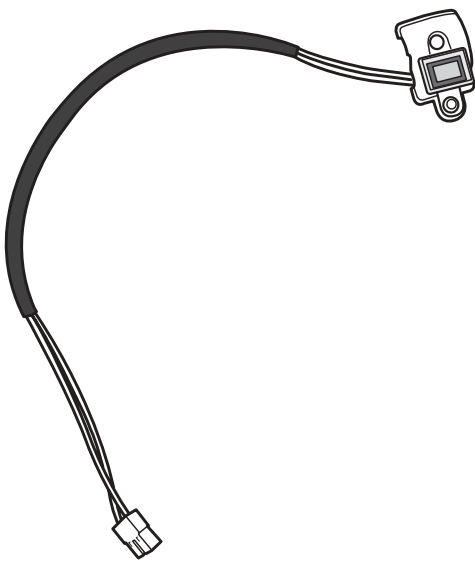

Handlebar Harness



Handgrip - 2

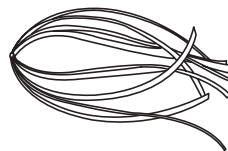

Tassel - 2



Battery Clamp



Wheel Axle - 2



Fork Axle

Parts



Hex Bushing - 2

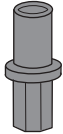

Extended Hex Bushing - 2



Axle Bushing - 2

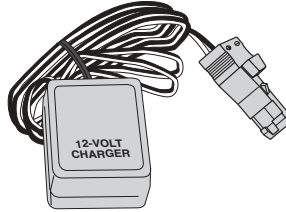

12 Volt Charger

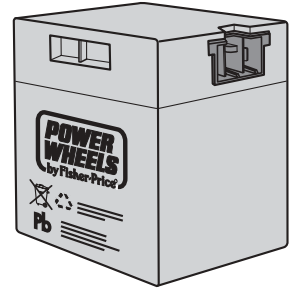

12 Volt Battery

Not Shown: Label Sheet

Note: Tighten and loosen all screws with a Phillips screwdriver. Do not over-tighten the screws.

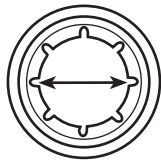

.437 (Large Diameter) Cap Nut - 4*

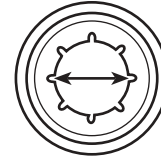

.354 (Small Diameter) Cap Nut - 2*



#8 x $\frac{3}{4}$ " Plastite Screw - 57*

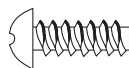

#8 x $\frac{1}{2}$ " Screw - 2



#8-32 x $\frac{3}{4}$ " Machine Screw - 2

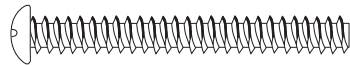

#8-32 x $1\frac{5}{8}$ " Machine Screw - 2



#8-32 Acorn Nut - 4

All Shown Actual Size

*For your convenience, two extra .437 (large diameter) cap nuts, one extra .354 (small diameter) cap nut, one extra #8 x $\frac{1}{2}$ " screw and one extra #8 x $\frac{3}{4}$ " plastite screw are included.

D

Parts Diagram

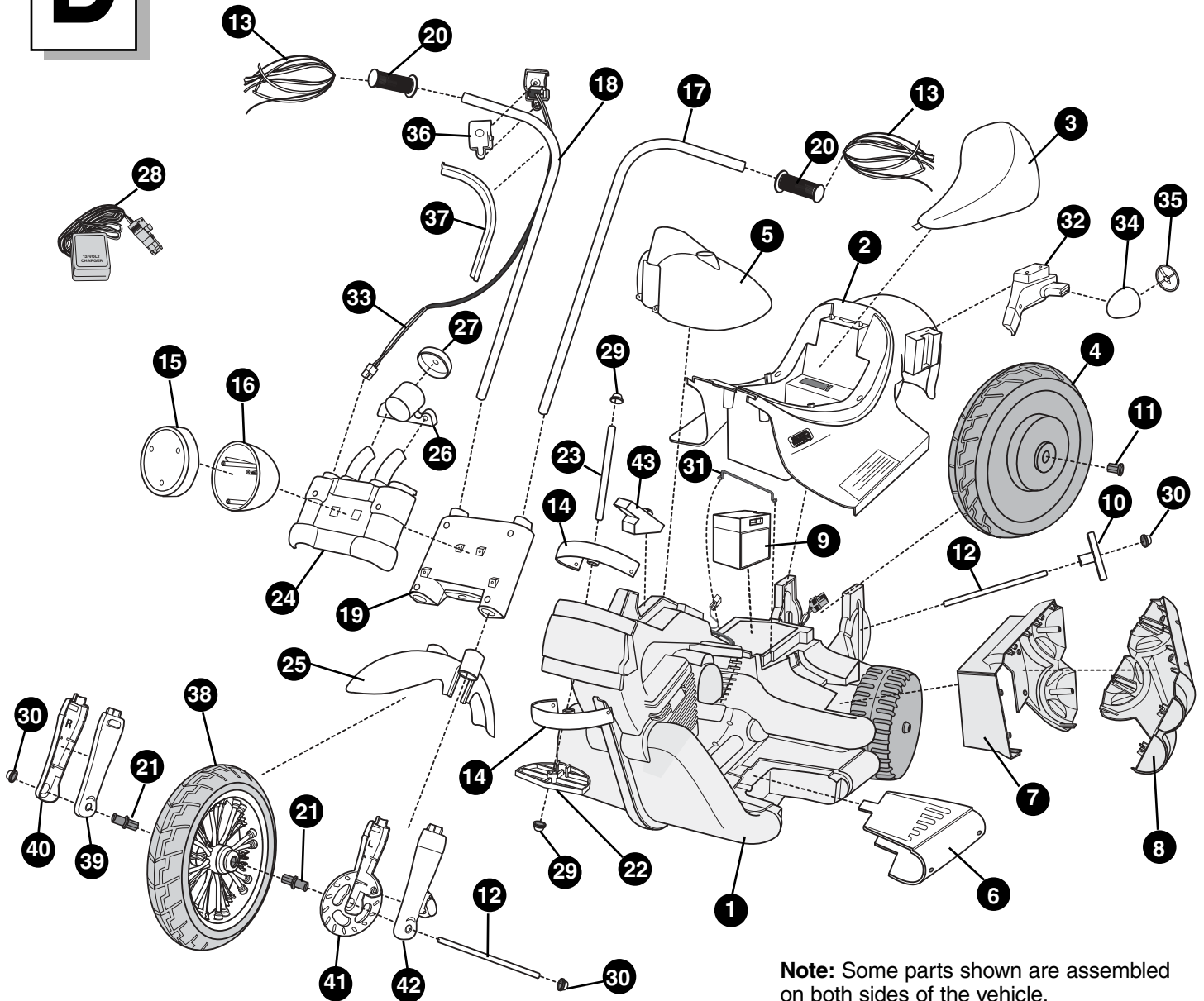

Note: Some parts shown are assembled on both sides of the vehicle.

- | | | |
|-----------------------------|-----------------------------|------------------------|
| 1. Vehicle Frame | 18. Right Handlebar | 34. Signal Housing - 2 |
| 2. Vehicle Body | 19. Front Fork | 35. Signal Lens - 2 |
| 3. Seat | 20. Handgrip - 2 | 36. Switch Cover |
| 4. Rear Wheel | 21. Extended Hex Bushing- 2 | 37. Wire Cover |
| 5. Tank | 22. Steering Stop | 38. Front Wheel |
| 6. Left Footboard | 23. Fork Axle | 39. Right Inner Shock |
| 7. Exhaust - Inner Half - 2 | 24. Front Fork Cover | 40. Right Outer Shock |
| 8. Exhaust - Outer Half - 2 | 25. Fender | 41. Left Inner Shock |
| 9. 12 Volt Battery | 26. Tachometer Housing | 42. Left Outer Shock |
| 10. Axle Bushing - 2 | 27. Tachometer Cover | 43. Sound Box |
| 11. Hex Bushing - 2 | 28. 12 Volt Charger | |
| 12. Wheel Axle - 2 | 29. .354 Cap Nut - 2 | |
| 13. Tassel - 2 | 30. .437 Cap Nut - 4 | |
| 14. Steering Bushing - 2 | 31. Battery Clamp | |
| 15. Headlight Lens | 32. Left Strut | |
| 16. Headlight Housing | 33. Handlebar Harness | |
| 17. Left Handlebar | | |

Not Shown

- #8 x 3/4" Screw - 57
 - #8 x 1/2" Screw - 2
 - #8-32 x 3/4" Machine Screw - 2
 - #8-32 x 1 5/8" Machine Screw - 2
 - #8-32 Acorn Nut - 4
- Label Sheet

ELECTRICAL HAZARD **WARNING**

- Battery can fall out and injure a child if vehicle tips over. Always use battery clamp.
- **PREVENT FIRE**
 - Never modify the electrical system. Alterations could cause a fire resulting in serious injury and could also ruin the electrical system.
 - Use of the wrong type battery or charger could cause a fire or explosion resulting in serious injury.
 - Use of Power Wheels® components in products other than Power Wheels® vehicles could cause overheating, fire or explosion.
- The battery must be handled by adults only. The battery is heavy and contains sulfuric acid (electrolyte). Dropping the battery could result in serious injury.
- Never allow children to charge the battery. Battery charging must be done by adults only. A child could be injured by the electricity involved in charging the battery.
- Read the safety instructions on the battery.
- Examine the battery, charger and their connectors for excessive wear or damage each time you charge the battery. If damage or excessive wear is detected, do not use the charger or the battery until you have replaced the worn or damaged part.

 **CAUTION**

Use the charger in dry locations only.

About Thermal Fuses

Your Power Wheels 12 volt battery is equipped with a built-in thermal fuse. The thermal fuse is a self-resetting safety device which automatically “trips” and shuts down operation of the vehicle if the vehicle is overloaded or the driving conditions too severe. Once a fuse has “tripped”, it will automatically reset itself after approximately 25 seconds and allow the vehicle to resume normal operations. To avoid repeated automatic shutdowns, do not overload the vehicle by exceeding the 65 lbs. maximum weight capacity or by towing anything behind the vehicle. Avoid severe driving conditions, such as driving up slopes or running into fixed objects, which can cause the wheels to stop spinning while power is still being supplied to the motors and make sure your child stops the vehicle before switching speeds or direction.

If a thermal fuse in a battery continually trips under normal driving conditions, please contact your local Power Wheels® Authorized Service Center. For the location of the Authorized Service Center nearest to you, please visit us on-line at www.powerwheels.com, or call **1-800-348-0751**.

Important Notes

- **Your new battery must be charged for at least 18 hours before you use it in your vehicle for the first time.**
- We recommend that you start charging your battery before beginning assembly of your new vehicle.
- The battery must be upright while charging.
- The charger is not a toy.
- Do not short circuit the battery.
- You do not need to remove the battery from your vehicle to recharge it.
- Before charging the battery, examine the battery case for cracks and other damage which may cause sulfuric acid (electrolyte) to leak during the charging process. If damage is detected, do not charge the battery or use it in your vehicle. Battery acid is very corrosive and can cause severe damage to surfaces it contacts.
- Do not charge the battery on a surface (such as kitchen counter tops) which could be damaged by the acid contained inside the battery. Take precautions to protect the surface on which you charge your battery.
- If your battery is old and will not accept a charge, do not leave it in your vehicle. Always remove a dead battery from the vehicle.
- Use only a Power Wheels® 12 volt charger (120 VAC 60 Hz 28W with an output of 12 VDC 1200mA) to charge your Power Wheels® 12 volt battery.
- When replacing the 12 volt battery, use only a Power Wheels® 12 volt battery.

Battery Charging

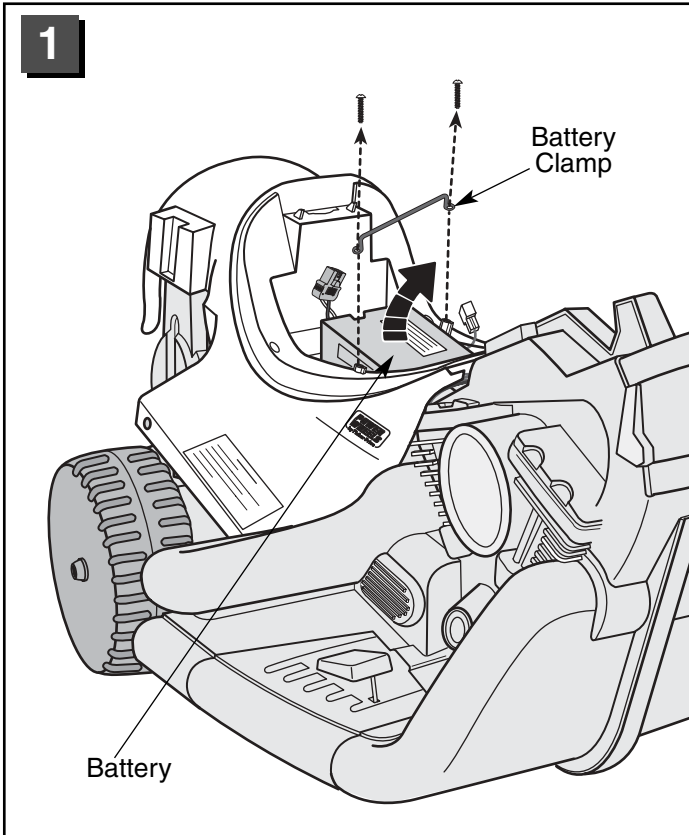

- Remove the two screws holding the battery clamp to the vehicle body.
- Remove the battery clamp. Set the battery clamp and screws aside. Do not throw out the battery clamp or screws. You will use them when installing your battery (see page 30).
- Remove the battery from the battery compartment.
- Remove and discard any cardboard in battery compartment which may have been added for shipping purposes.

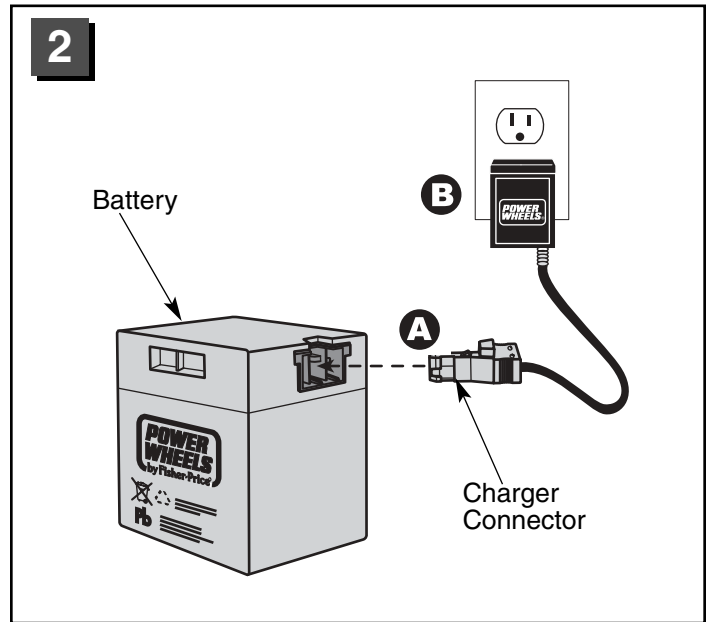

- Plug the charger connector into the battery **A**.
- Plug the charger into a standard 120 volt wall outlet **B**.

Note: If power flow to the wall outlet is controlled by a switch, make sure the switch is "ON".

- Before first-time use, charge the battery for **at least 18 hours**. Never charge the battery longer than 30 hours.
- Recharge the battery for at least 14 hours after each use of your vehicle. Do not charge the battery longer than 30 hours.
- Once the battery is charged, pull firmly on the charger connector to disconnect it from the battery. Unplug the charger from the wall outlet. The battery is now ready to be installed in your vehicle. Please see the Battery Installation section on page 30 for detailed instructions on installing your battery. If your battery is already installed in your vehicle, simply plug the motor harness connector into the battery and replace the seat.

WARNING

Children can be harmed by small parts, sharp edges and sharp points in the vehicle's unassembled state, or by electrical items. Care should be taken in unpacking and assembly of the vehicle.

Children should not handle parts, including the battery, or help in assembly of the vehicle.

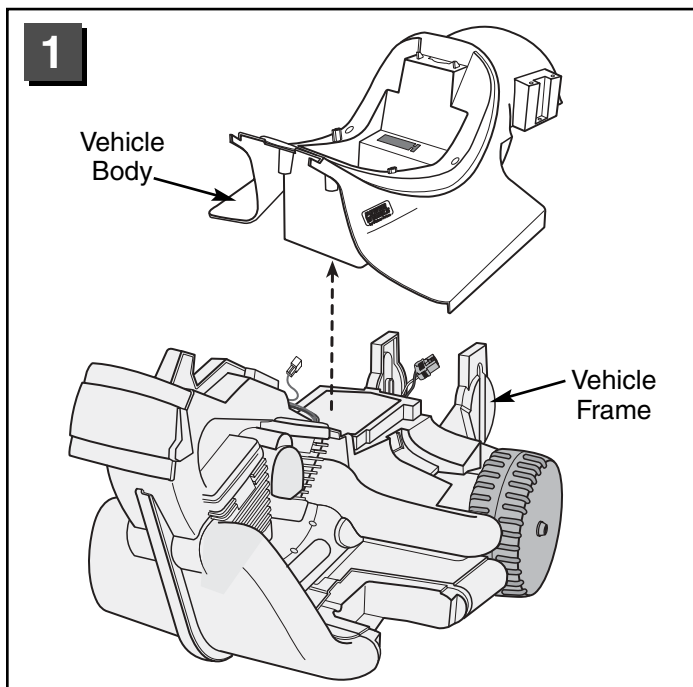

- Lift to remove the vehicle body from the vehicle frame.

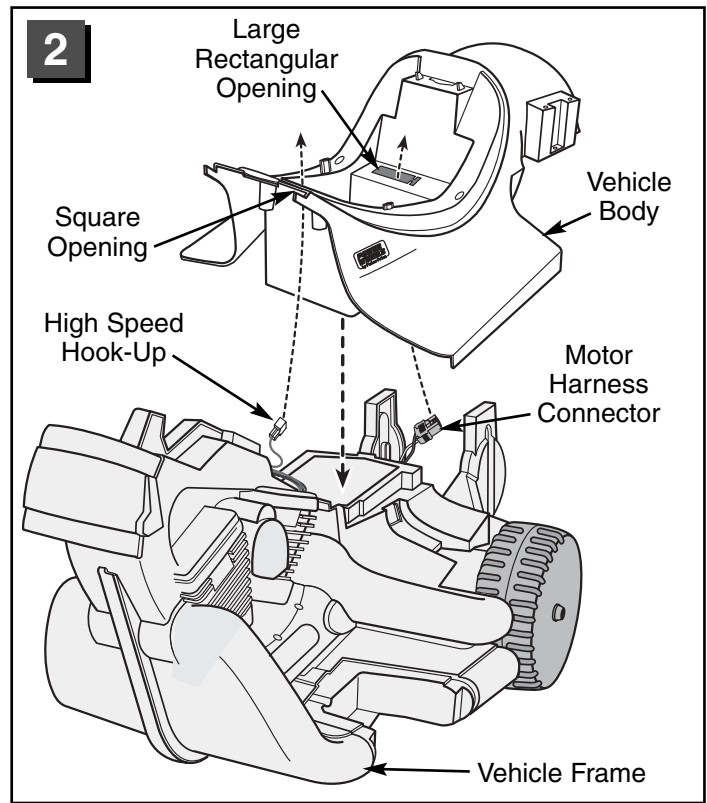

- Position the vehicle body on top of the vehicle frame.
- Fit **motor harness connector** up through the **large rectangular** opening in the vehicle body.
- Fit the **high speed hook-up connector** through the **square** opening near the front of the vehicle body.

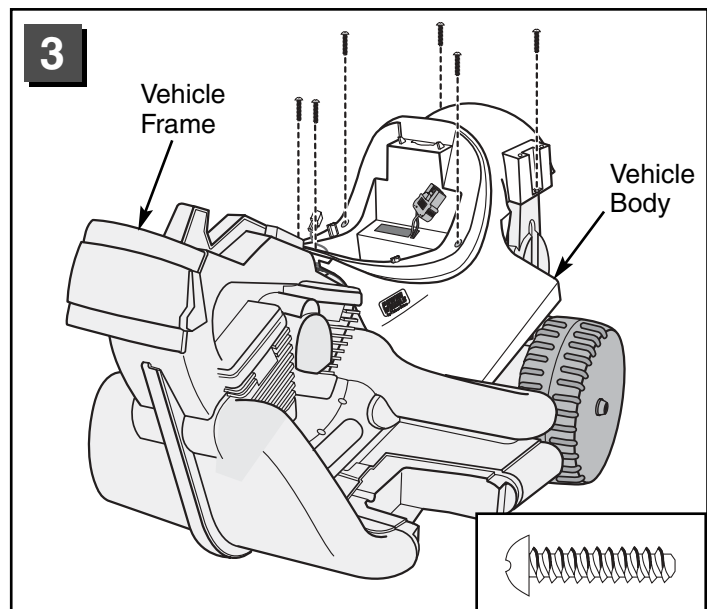

- Insert six #8 x $\frac{3}{4}$ " screws through the vehicle body and into the vehicle frame. Make sure the holes in the vehicle body and frame are aligned. Tighten the screws.

Assembly

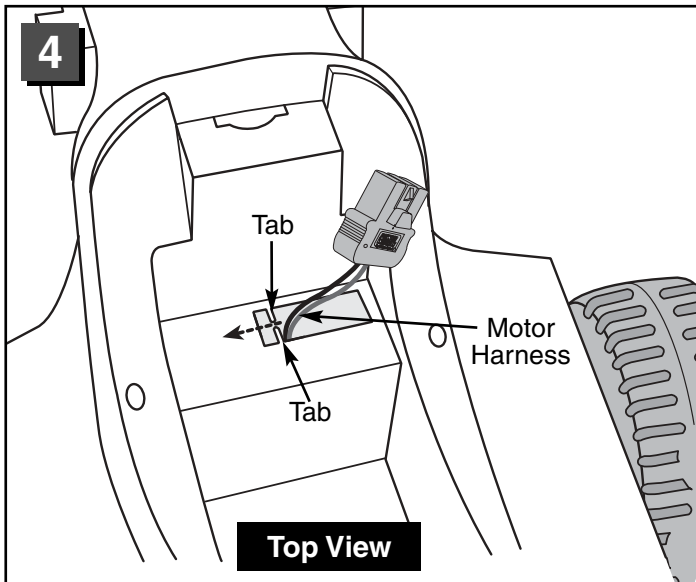

- Fit the motor harness between the vehicle body tabs.

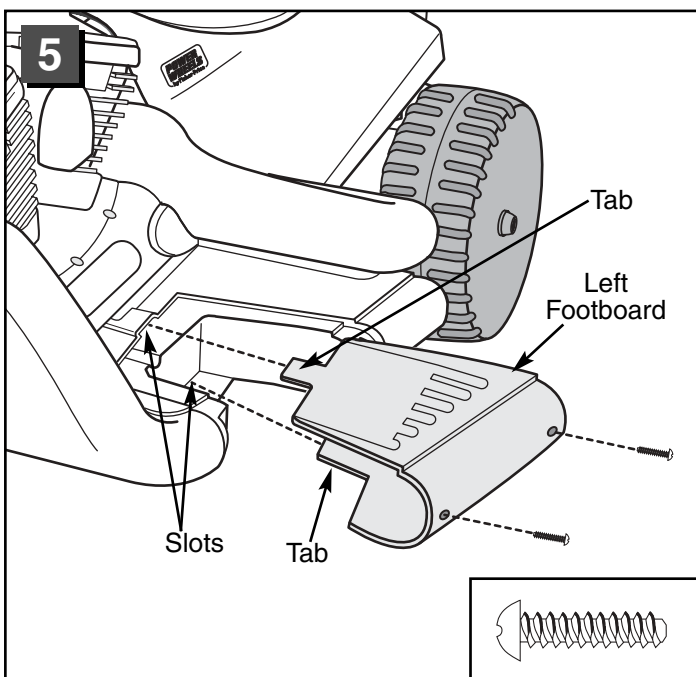

- Fit the tabs on the left footboard into the slots in the left side of the vehicle frame. **Make sure both tabs are in the slots.**
- Hint: You may need to squeeze the left footboard in order to align the tabs with the slots.*
- Insert two #8 x 3/4" screws into the left footboard as shown. Tighten the screws.

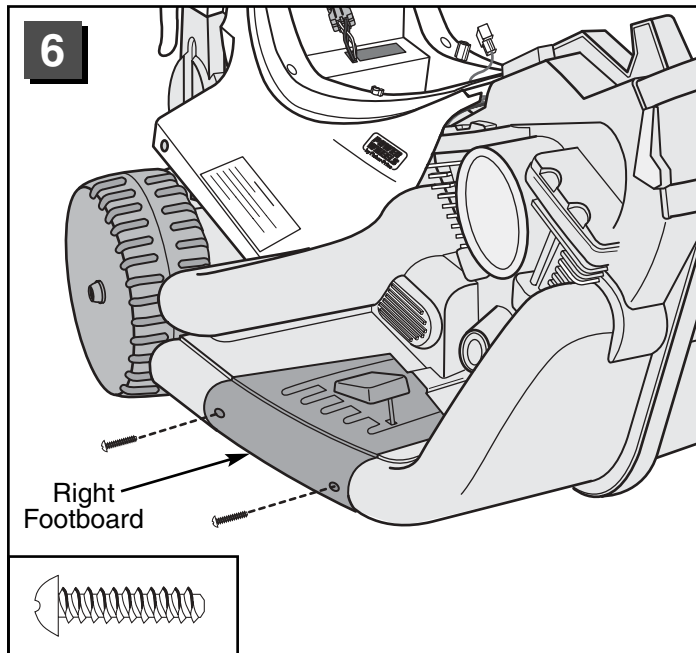

- The right footboard was inserted in the vehicle frame at the factory. **Make sure the right footboard is in place.**
- Insert two #8 x 3/4" screws into the right footboard as shown. Tighten the screws.

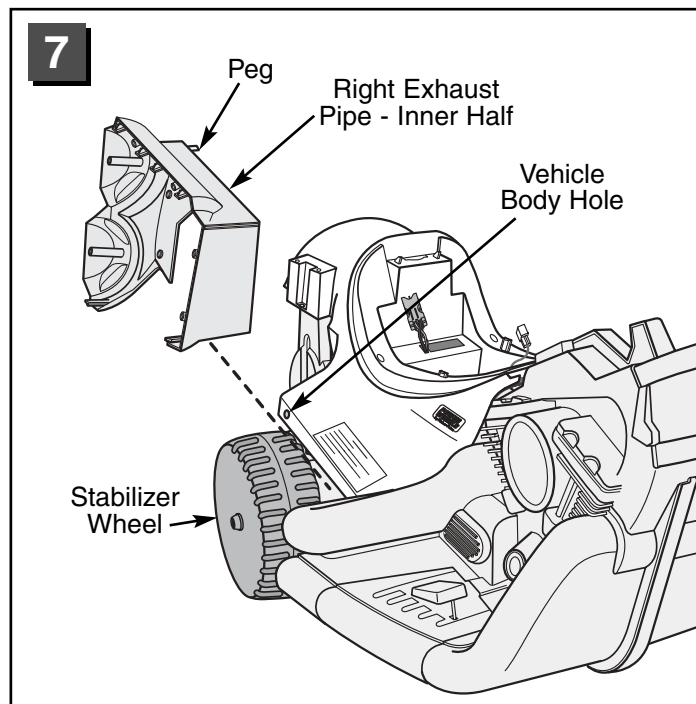

- Separate the exhaust pipe set pieces. Note the R (right side) and L (left side) markings on the inside of each piece.
- Fit the inner half of the right exhaust pipe (R) over the stabilizer wheel on the right side of the vehicle. Make sure the peg on the inner exhaust pipe fits into the hole in the vehicle body.

Assembly

8

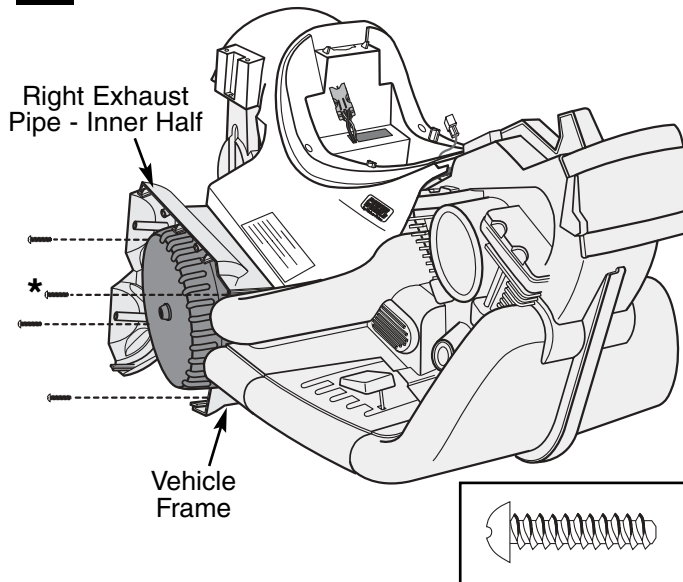

Hint: Use a long-shaft Phillips screwdriver to complete this assembly step.

- Align the holes in the inner half of the right exhaust pipe with the holes in the vehicle frame.
- Insert four #8 x 3/4" screws through the inner half of the right exhaust pipe and into the vehicle frame.

IMPORTANT! The screw marked with an asterisk * in the illustration above must go through the hole in the inner half of the right exhaust pipe, the vehicle body and into the vehicle frame. Make sure all the holes are properly aligned and the **screw goes through all three parts.**

- Tighten the screws.

9

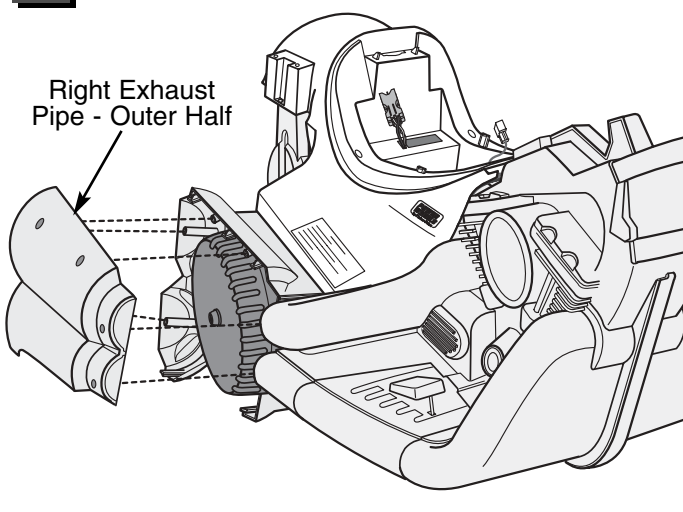

- Fit the outer half of the right exhaust pipe (R) to the inner half of the right exhaust pipe.

10

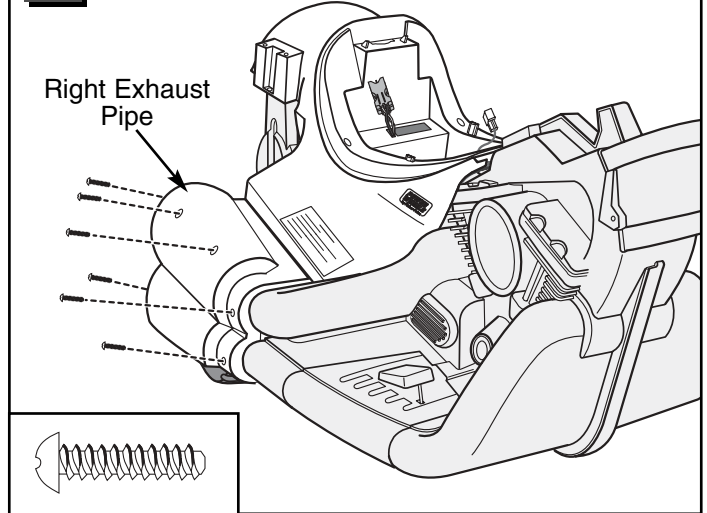

- With the holes of both halves aligned, insert six #8 x 3/4" screws to join the two halves of the right exhaust pipe.
- Tighten the screws.
- Repeat steps 7 through 10 to assemble the left exhaust pipe (L) to the left side of the vehicle.

11

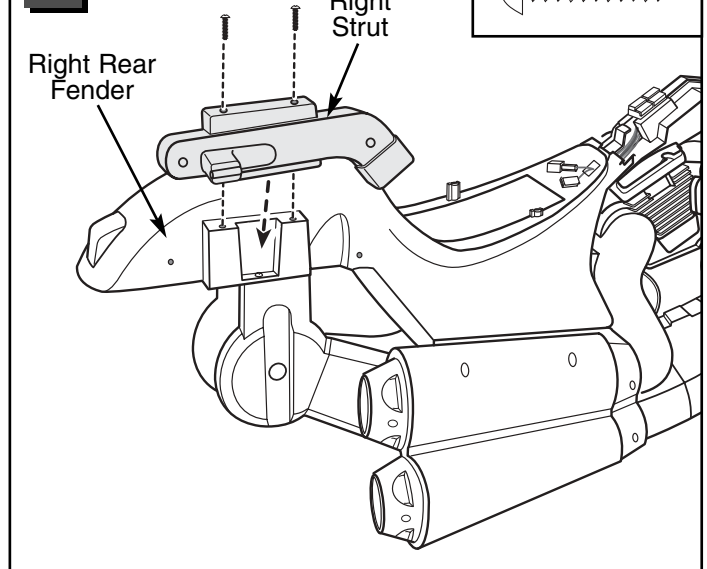

- Fit the right strut onto the right rear fender of the vehicle body.
- Insert two #8 x 3/4" screws into the top of the right strut and tighten.

Assembly

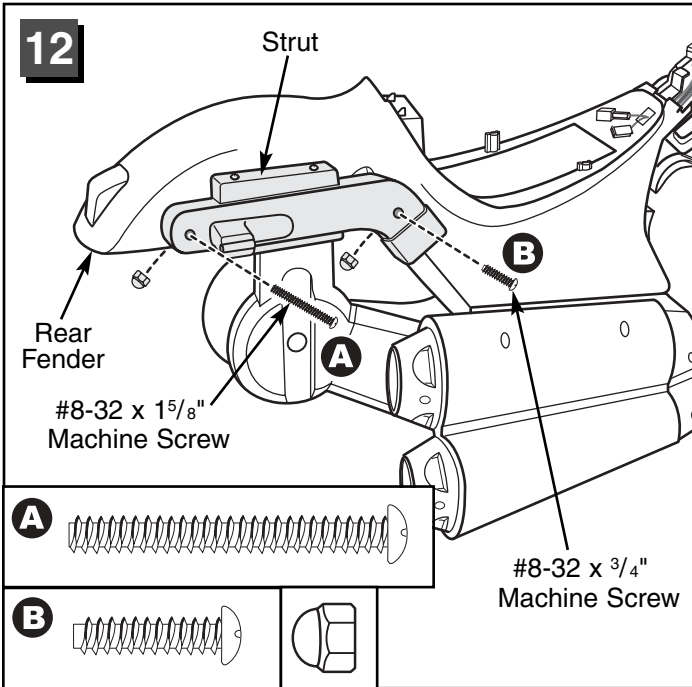

- First, insert a #8-32 x 1⁵/₈" machine screw through the hole in the side of the right strut that is closest to the rear of the vehicle body, as shown **A**.
- Attach an #8-32 acorn nut to the end of the screw, inside the rear fender. Hand-tighten the acorn nut.
- Then, insert a #8-32 x 3³/₄" machine screw through the hole in the side of the right strut that is towards the front of the vehicle body, as shown **B**.
- Attach an #8-32 acorn nut to the end of the screw, inside the rear fender. Hand-tighten the acorn nut.
- Using an adjustable wrench to hold the acorn nuts inside the rear fender, tighten the screws.
- Repeat steps 11 and 12 to assemble the left strut to the left rear fender of the vehicle body.

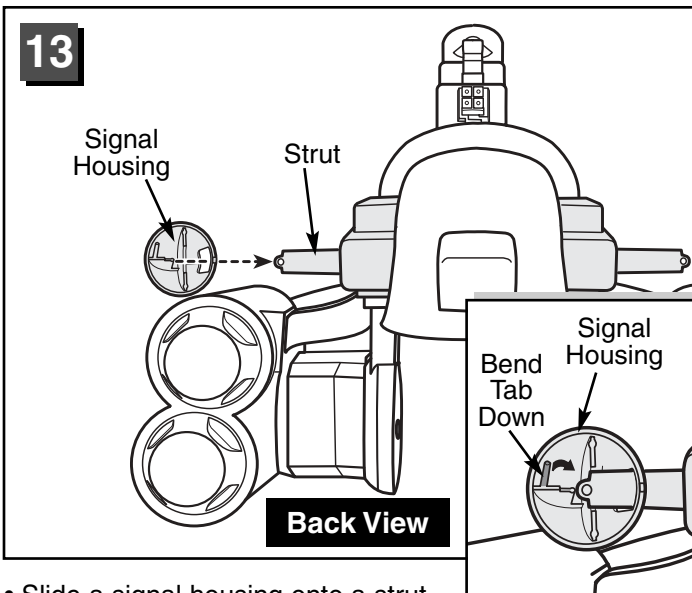

- Slide a signal housing onto a strut.
- Bend the tab inside the signal housing down.

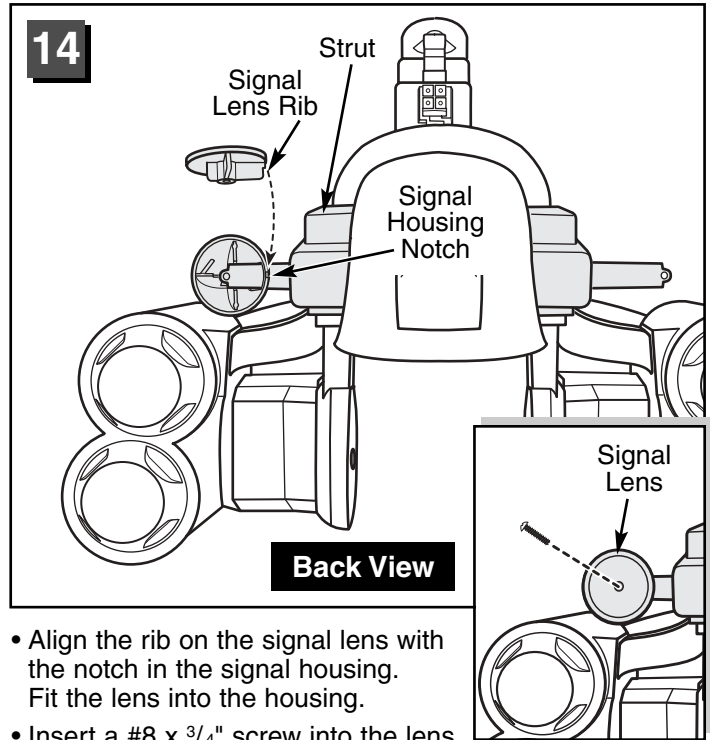

- Align the rib on the signal lens with the notch in the signal housing. Fit the lens into the housing.
- Insert a #8 x 3/4" screw into the lens and tighten.
- Repeat steps 13 and 14 to assemble the other signal housing and signal lens to the other strut.

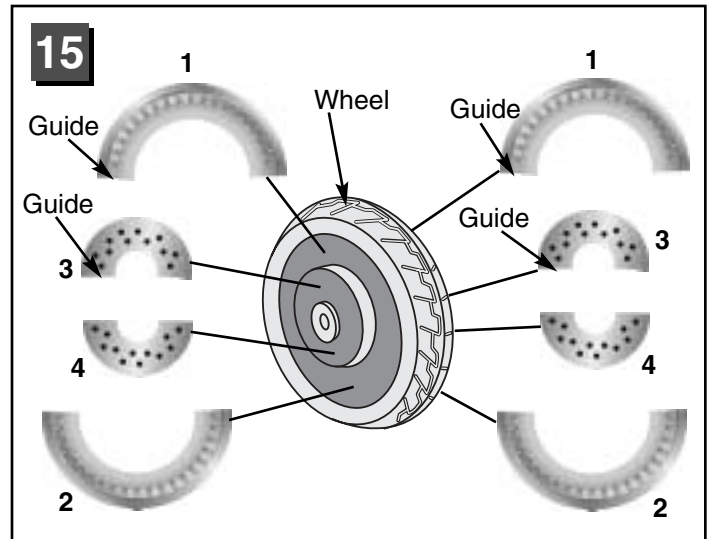

- Before applying labels to the rear wheel, wipe it with a clean, dry cloth to make sure it is free of dirt and oils. Make sure your hands are clean.
- Apply labels to both sides of the wheel as shown in the illustration.

IMPORTANT! Labels 1 and 2 are designed to slightly overlap; and labels 3 and 4 are designed to slightly overlap. For each side, apply label 1 before applying label 2. Align the edge of label 2 with the guide marks on label 1. Apply label 3 before applying label 4. Align the edge of label 4 with the guide marks on label 3.

Assembly

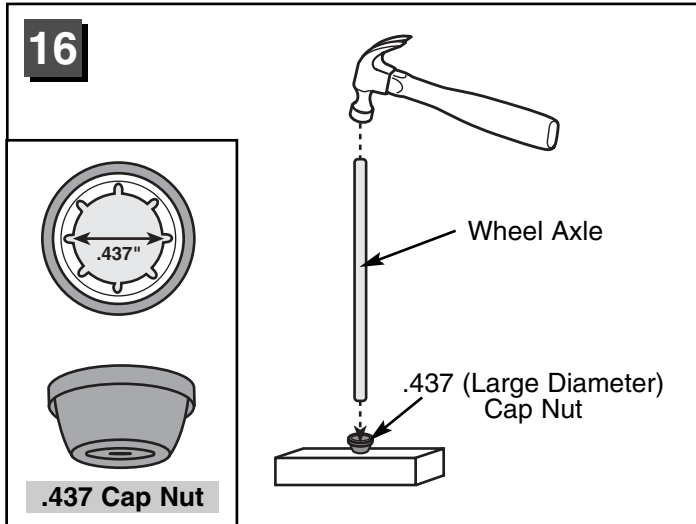

- Separate the fork axle from the two wheel axles. (The fork axle is shorter than the wheels axles.) Set the fork axle aside for assembly step 39.
- Place a .437 (large diameter) cap nut on a flat surface, inside up. Fit the end of a wheel axle into the cap nut.
- Tap the opposite end of the wheel axle with a hammer to secure the cap nut on the axle. Pull on the cap nut to make sure it is secure.
- Repeat this procedure to assemble a .437 (large diameter) cap nut to one end of the other wheel axle.
- Set one of the wheel axles aside for assembly step 52.

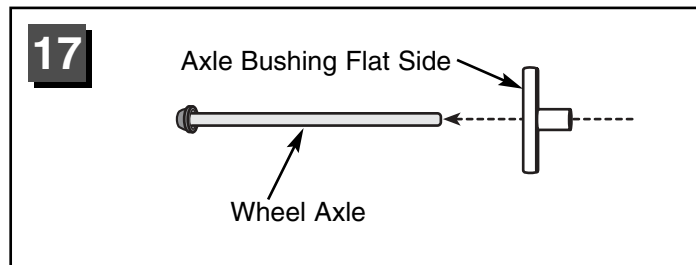

- Slide an axle bushing, *flat side first*, on the wheel axle.

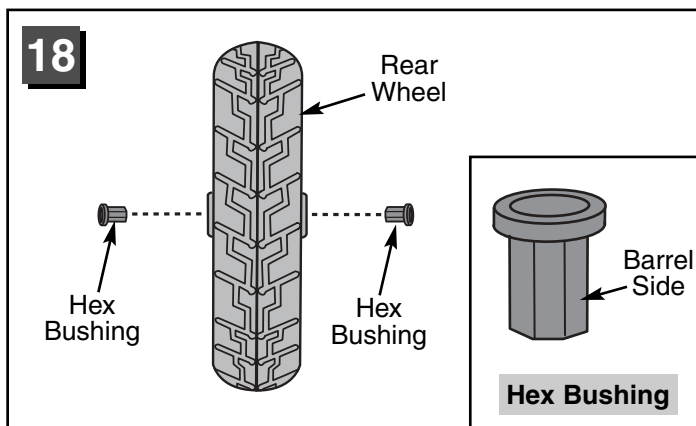

- Fit two hex bushings, *barrel side first*, into the hole in the rear wheel.

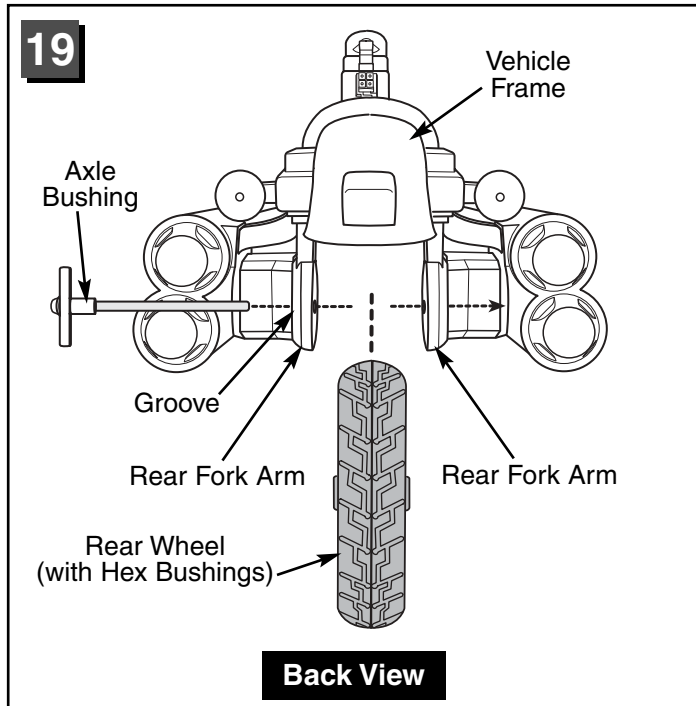

- Position the vehicle assembly so that the back is facing you.
- While holding the hex bushings in place, position the rear wheel between the rear fork arms of the vehicle frame.
- Slide the wheel axle (with axle bushing) through one rear fork arm, through the wheel (with hex bushings) and out through the other rear fork arm. Make sure the wheel axle bushing fits into the groove in the rear fork arm.

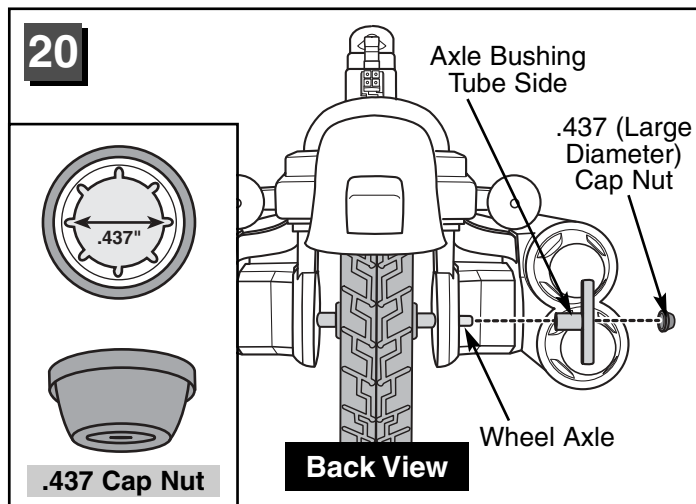

- Slide an axle bushing, *tube side first*, onto the end of the wheel axle. Make sure the flat end of the axle bushing fits into the groove in the rear fork arm.
- Fit a .437 (large diameter) cap nut on the end of the wheel axle. Tap the .437 cap nut with a hammer to secure it on the end of the wheel axle.

Hint: You may need the help of another adult to support the other end of the wheel axle.

- 15 • Pull on the .437 cap nut to make sure the rear wheel assembly is secure.

Assembly

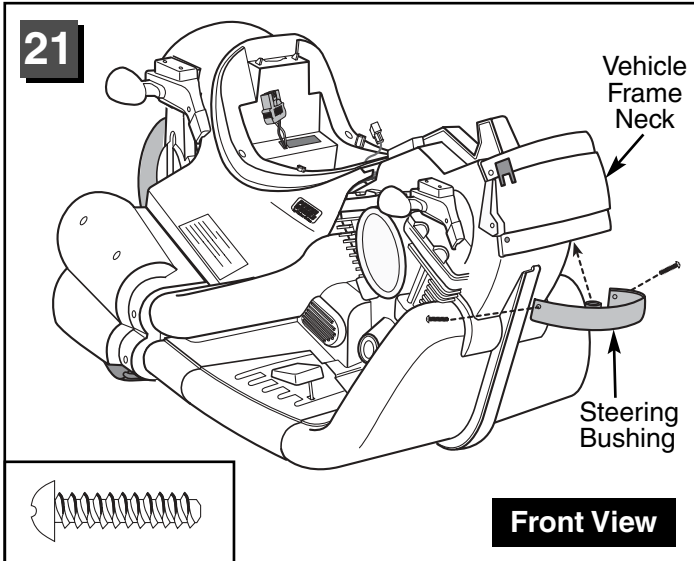

- Position the vehicle frame so that the front faces you.
- Fit a steering bushing underneath the neck of the vehicle frame.
- Insert a #8 x $\frac{3}{4}$ " screw into each end of the steering bushing and tighten.

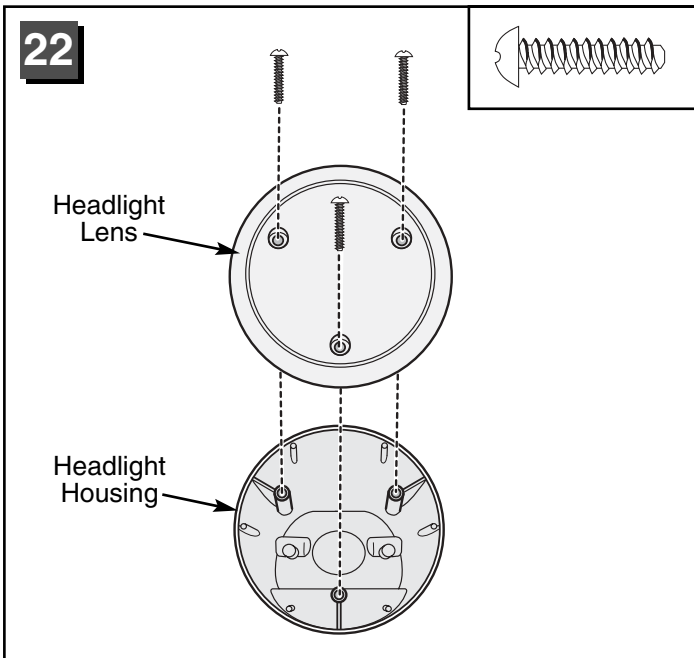

- Fit the headlight lens onto the headlight housing.
- Insert three #8 x $\frac{3}{4}$ " screws into the headlight lens and tighten.

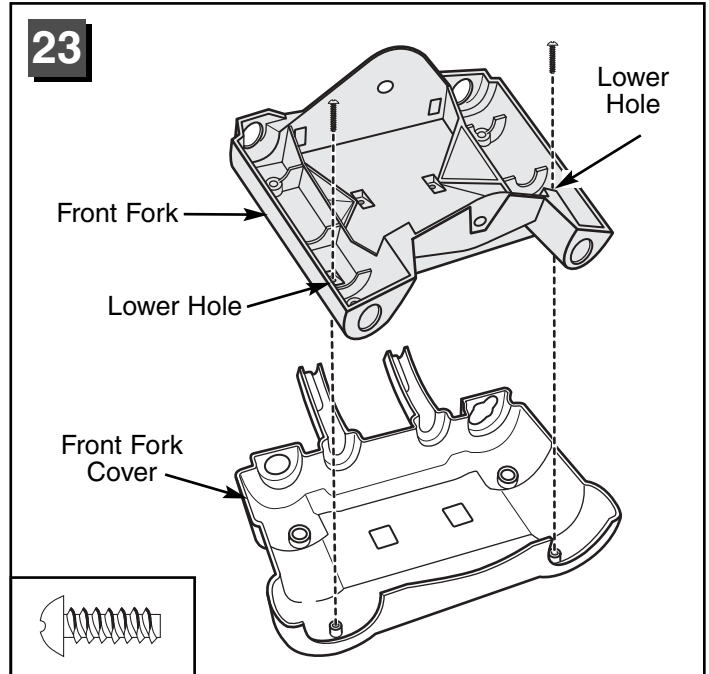

- Fit the front fork into the front fork cover.
- Insert two #8 x $\frac{1}{2}$ " screws into the lower holes in the front fork and tighten.

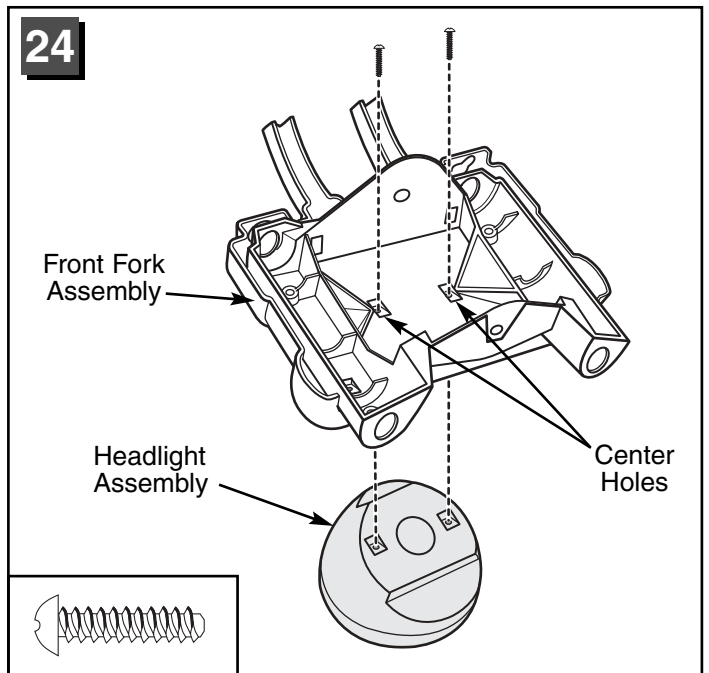

- Position the headlight assembly with the lens down on a flat surface.
- Fit the front fork assembly onto the back of the headlight assembly, as shown.
- Insert two #8 x $\frac{3}{4}$ " screws through the center holes in the front fork assembly and into the headlight assembly.
- Tighten the screws.

Assembly

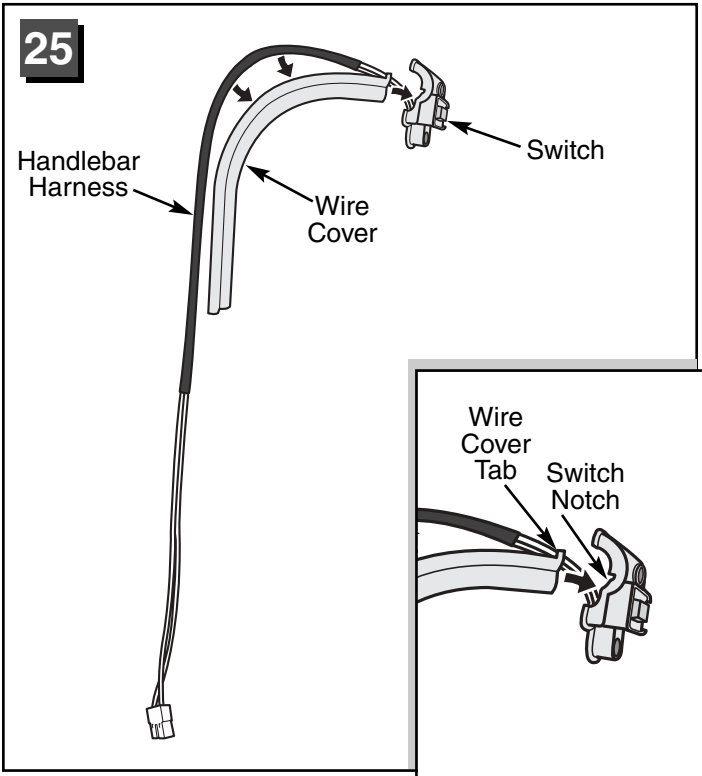

- Fit the wrapped portion of the handlebar harness into the wire cover.
- Fit the tab on the wire cover into the notch in the switch to lock the two parts together.

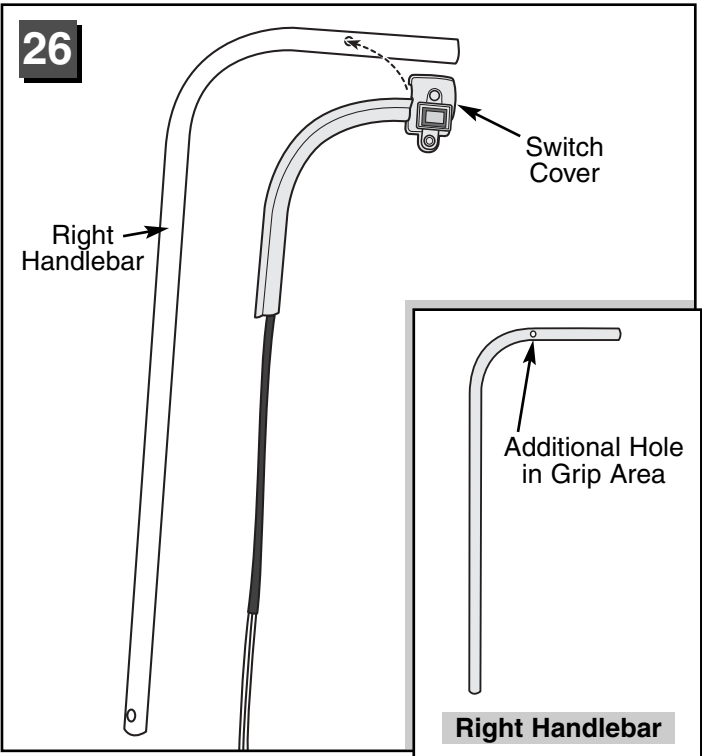

- Locate the right handlebar. The right handlebar has an additional hole in the grip area.
- Fit the switch to the right handlebar, making sure the screw hole in the switch aligns with the screw hole in the right handlebar.

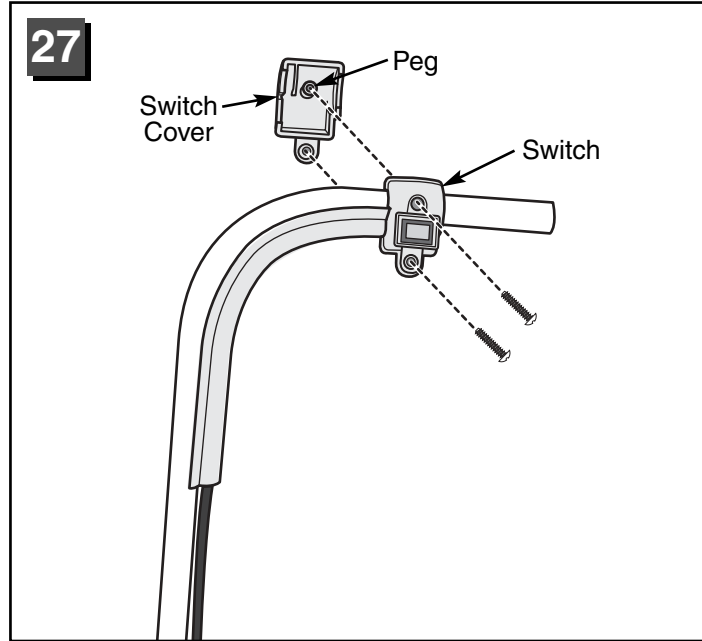

- Fit the switch cover peg through the hole in the right handlebar and the switch.
- While holding the two parts firmly together, insert two #8 x 3/4" screws into the switch and tighten.

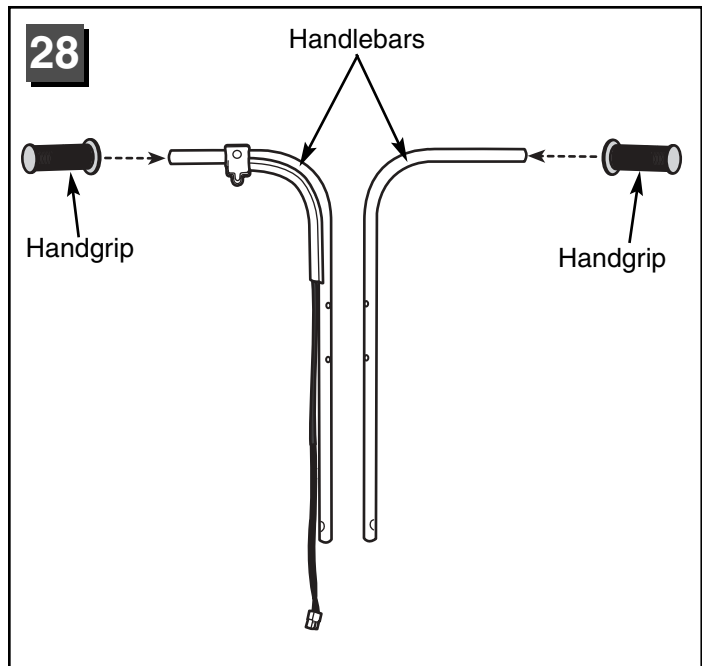

- Fit a handgrip on the end of each handlebar.
- Hint:** If it is difficult to slide the handgrips onto the handlebars, moisten the inside of the handgrips with water.

Assembly

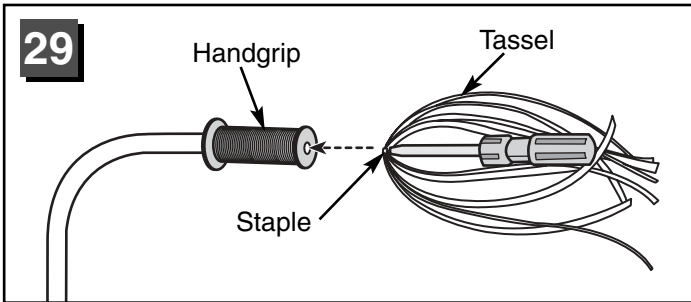

- Using a slotted screwdriver, push the staple in the center of a tassel into the hole in the end of a handgrip.
- Repeat this procedure to attach the other tassel to the other handlebar.

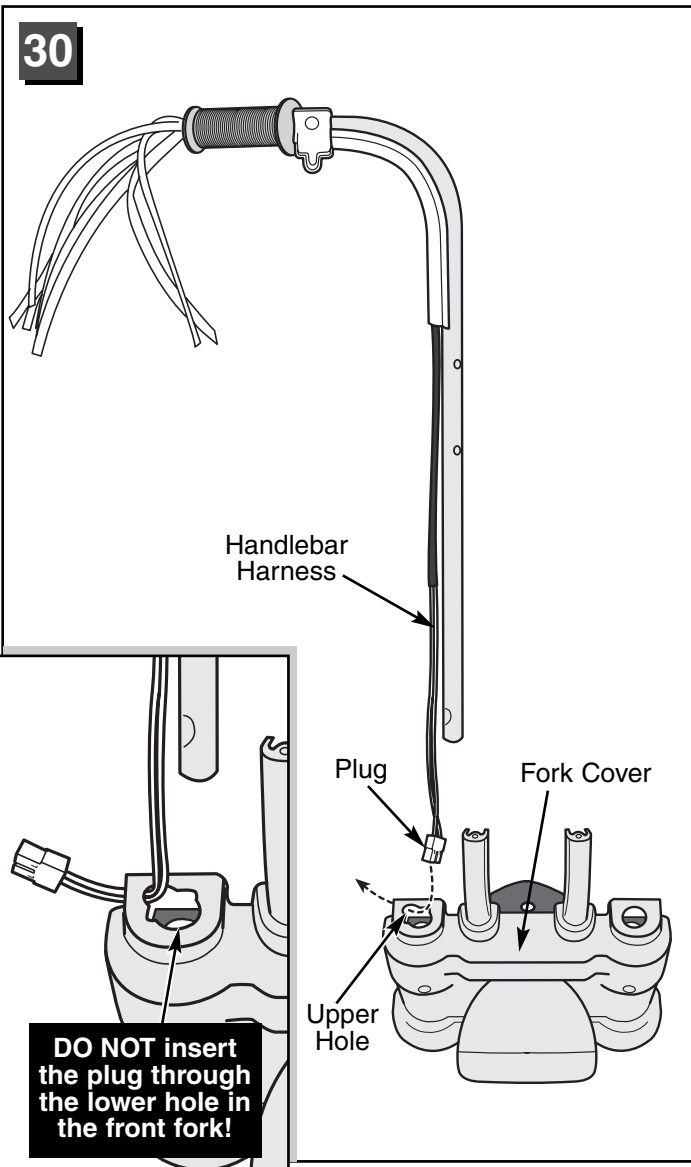

- Position the front fork so that it is upright and facing you.
- Insert the handlebar harness plug through the **upper hole** in the front fork. **Do not insert the plug through the lower hole in the front fork.**

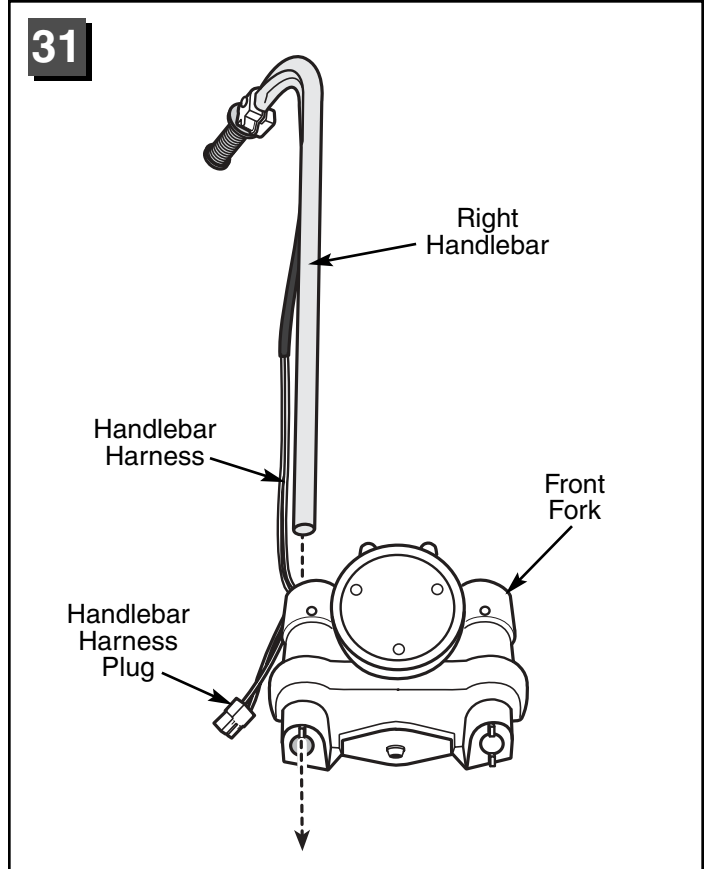

- While making sure the handlebar harness plug remains inserted through **only the upper hole** in the front fork, slide the right handlebar down through the upper and lower holes in the front fork.

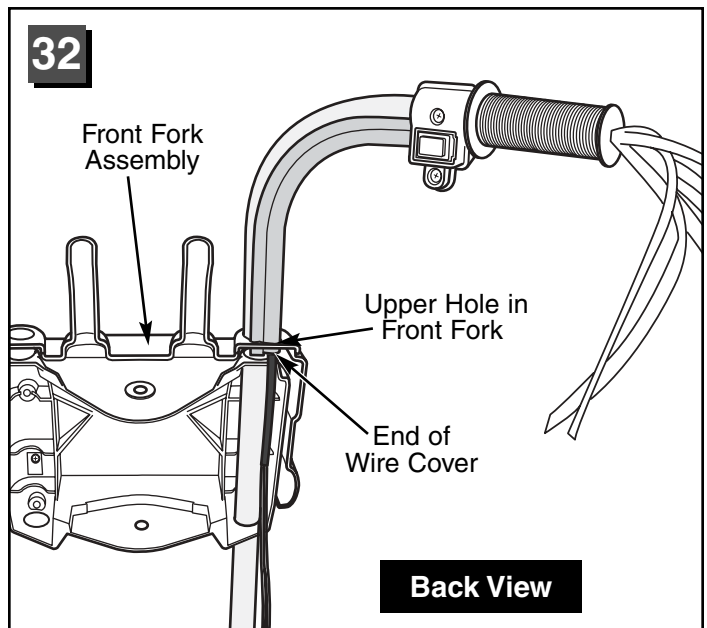

- Turn the front fork assembly around so the back is facing you.
- Slide the end of the wire cover into the upper hole in the front fork, as shown.

Assembly

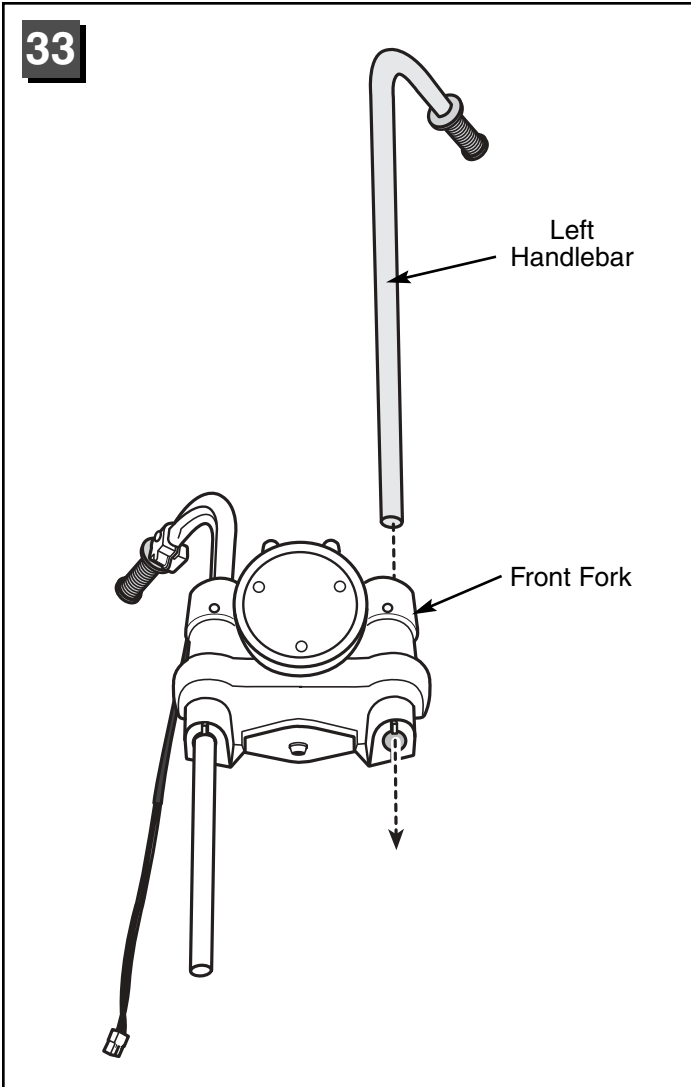

- Turn the front fork around so the front is facing you.
- Slide the left handlebar through the upper and lower holes in the front fork.

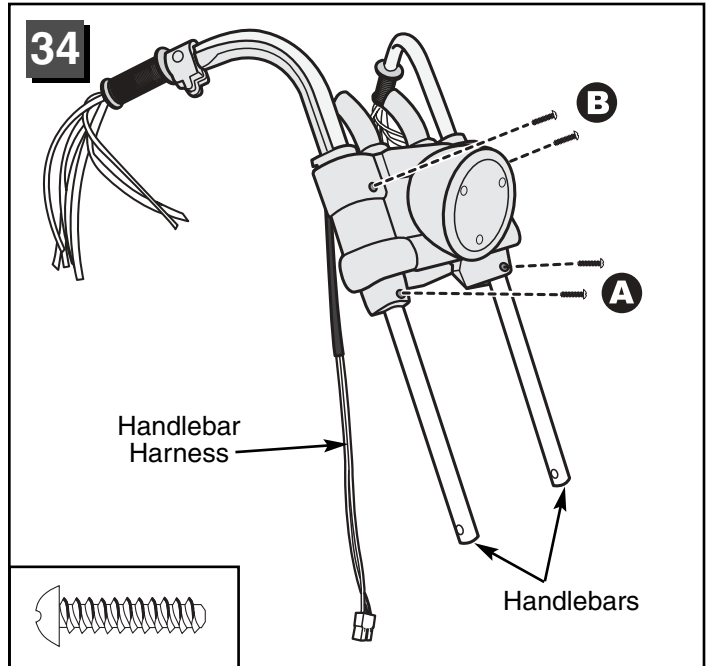

- Align the screw holes in each handlebar with the screw holes in the front fork.
- First, insert two #8 x $\frac{3}{4}$ " screws through the **lower holes** in the front fork and into each **lower hole** in each handlebar **A** and hand tighten. Do not tighten the screws completely. These screws will be tightened in step 54.
- Next, insert two #8 x $\frac{3}{4}$ " screws through the **upper holes** in the front fork and into each **upper hole** in each handlebar **B** and hand tighten. Do not tighten the screws completely. These screws will be tightened in step 54.

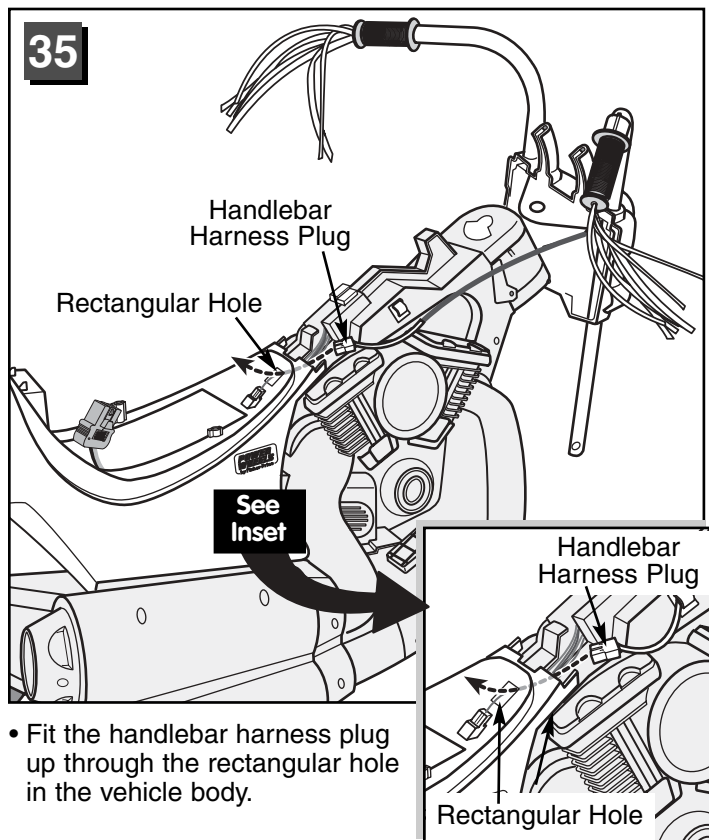

- Fit the handlebar harness plug up through the rectangular hole in the vehicle body.

Assembly

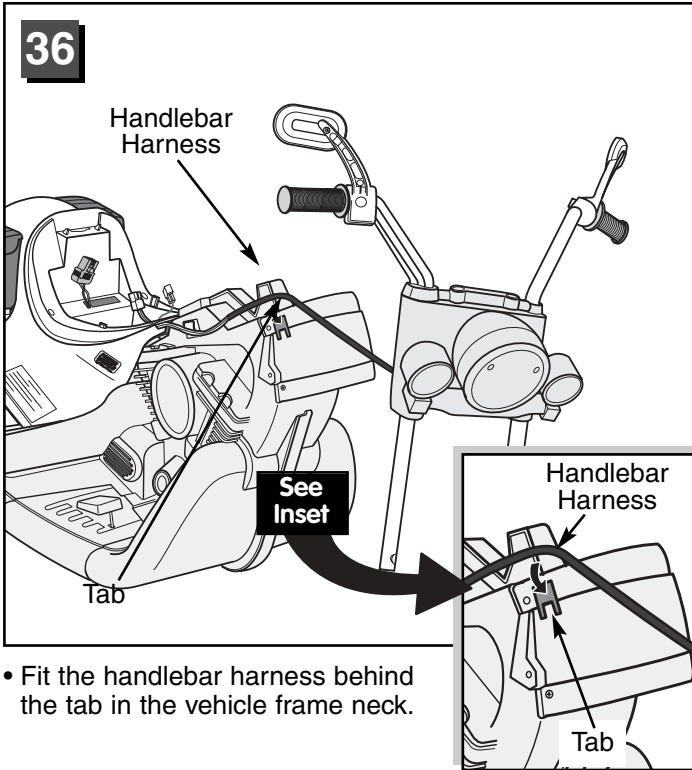

- Fit the handlebar harness behind the tab in the vehicle frame neck.

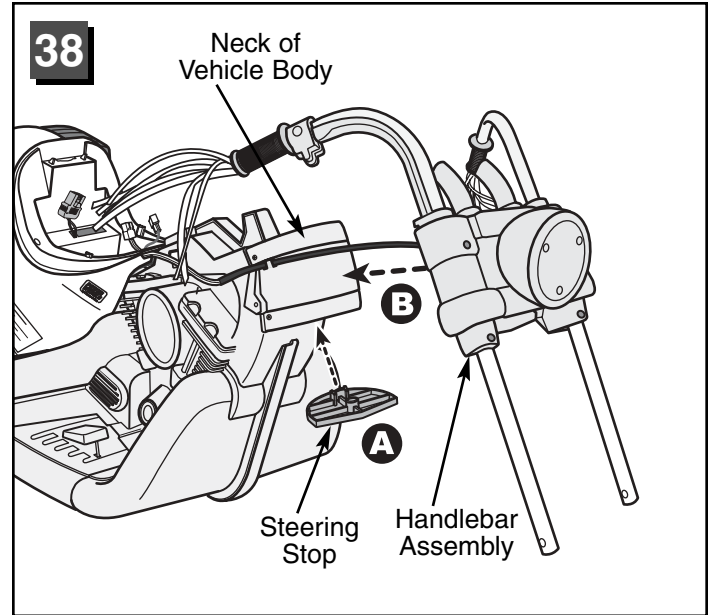

- First, fit the tab on the steering stop into the curved slot in the lower steering bushing **A**.
- Hold the steering stop in place.
- Then, slide the handlebar assembly on the vehicle frame neck and over the steering stop **B**.

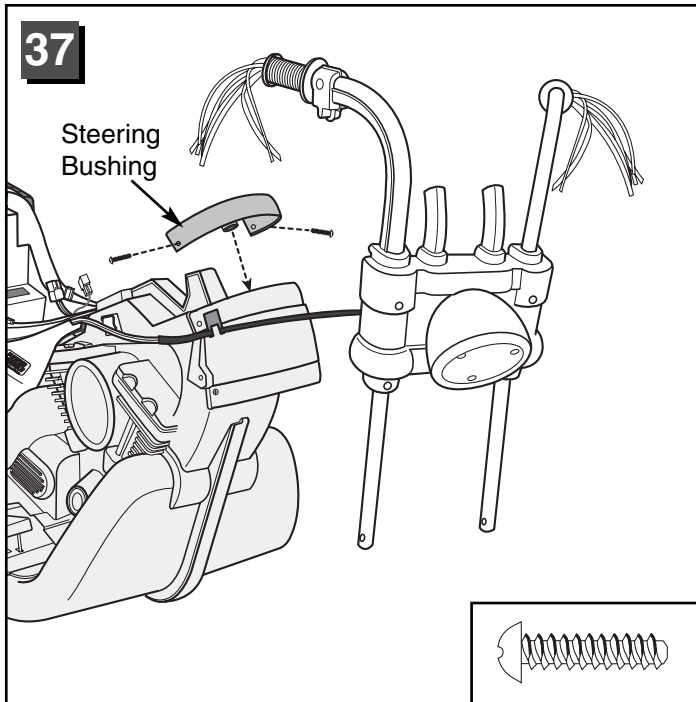

- Fit the remaining steering bushing onto the top of the vehicle frame neck.
- Insert two #8 x 3/4" screws into each end of the steering bushing and tighten.

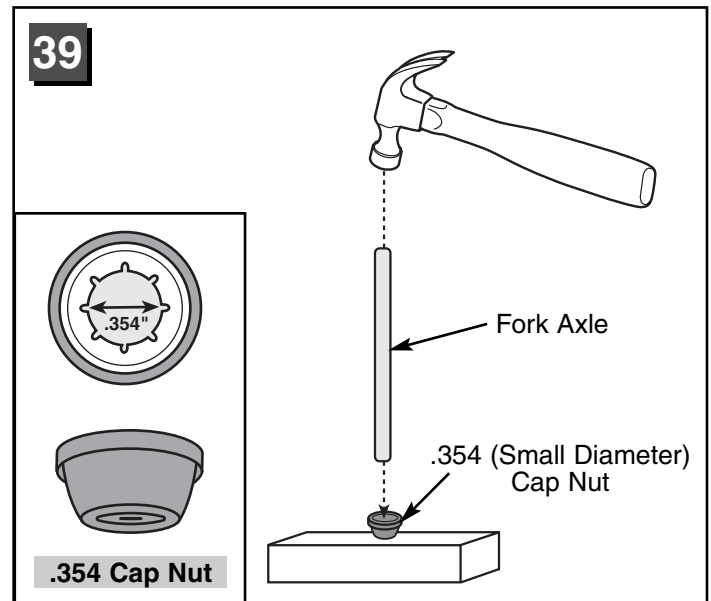

- Place a .354 (small diameter) cap nut on a flat surface, inside up. Fit the end of the fork axle into the cap nut.
- Tap the opposite end of the fork axle with a hammer to secure the cap nut on the axle. Pull on the cap nut to make sure it is securely assembled.

Assembly

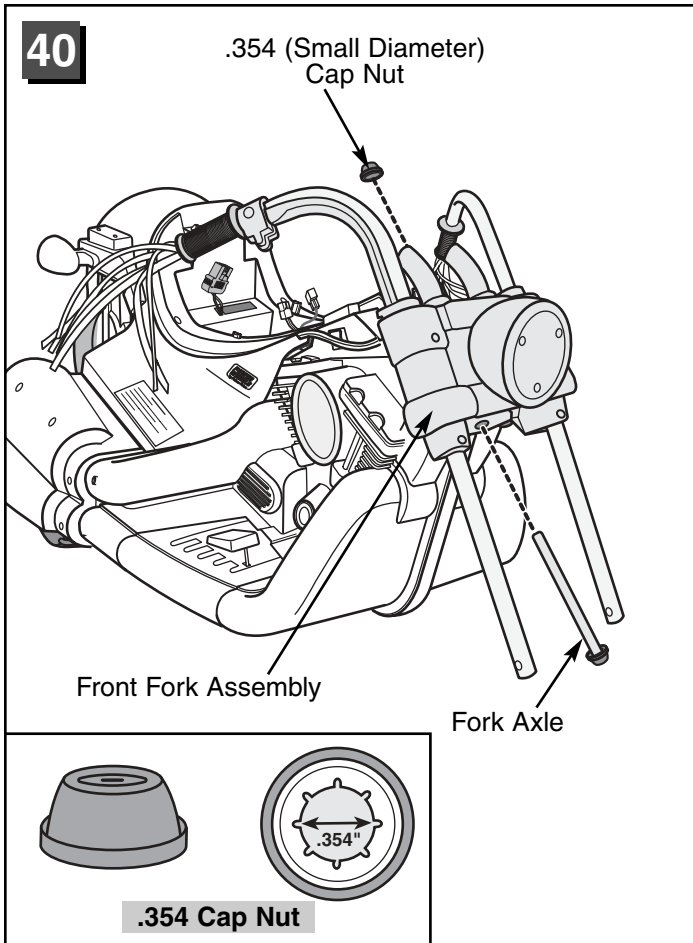

- Slide the fork axle up through the bottom of the front fork, through the frame neck and steering stop, and out the top of the front fork.
- Fit a .354 (small diameter) cap nut on the end of the fork axle.
- Support the fork axle and tap the cap nut with a hammer to secure it on the end of the axle.

Hint: You may need the help of another adult to hold the front axle in place while you secure the cap nut.

- Pull on the .354 cap nut to make sure it is secure on the fork axle.

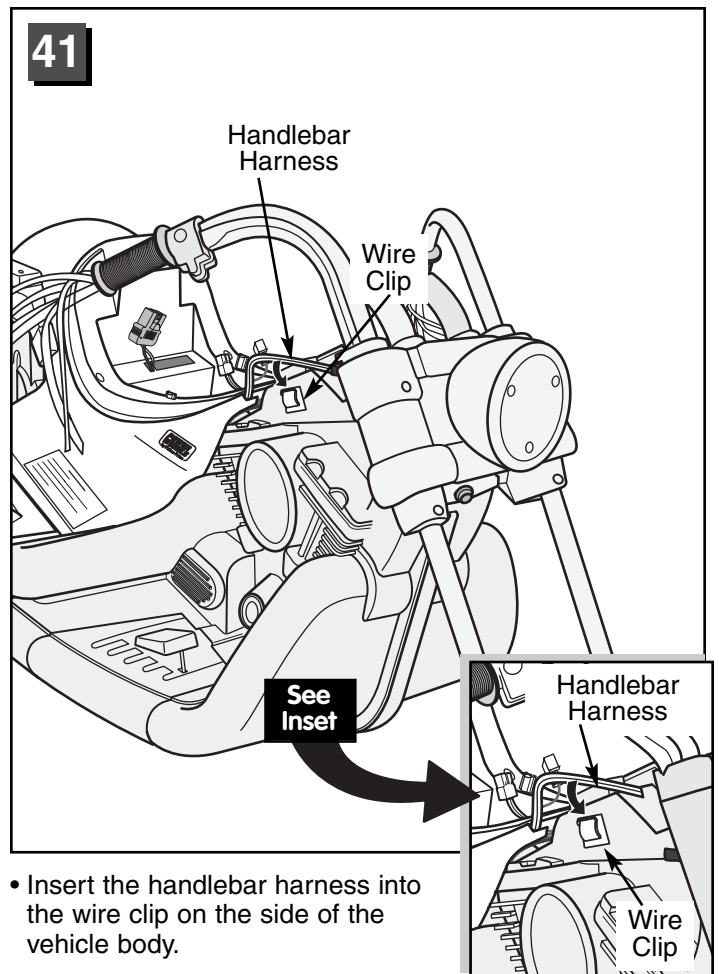

Assembly

42

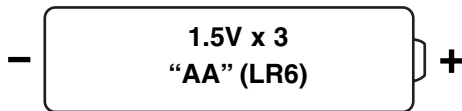
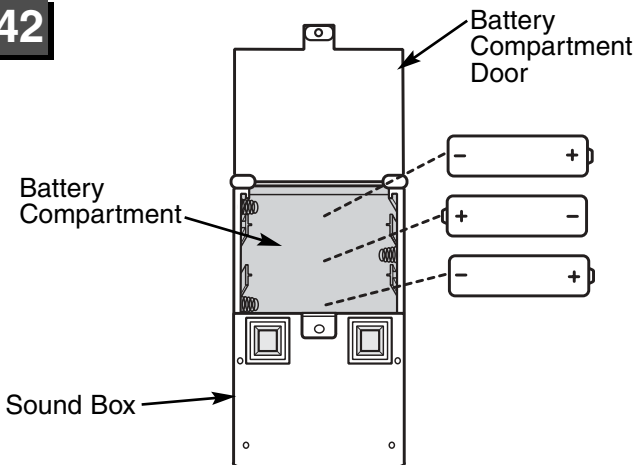

SHOWN ACTUAL SIZE

- Loosen the screw in the sound box battery compartment door using a Phillips screwdriver and open the battery compartment.
- Insert three "AA" (LR6) **alkaline** batteries in the sound box.

Hint: For longest battery life, use only **alkaline** batteries.

- Close the battery compartment door and tighten the screw using a Phillips screwdriver. Do not over-tighten.

Battery Tips

Batteries may leak fluids that can cause chemical burn injury or ruin your product. To avoid battery leakage:

- Do not mix old and new batteries or batteries of different types: alkaline, standard (carbon-zinc) or rechargeable (nickel-cadmium).
- Insert batteries as indicated inside the battery compartment.
- Remove batteries during long periods of non-use. Always remove exhausted batteries from the product. Dispose of batteries safely. Do not dispose of batteries in a fire. The batteries may explode or leak.
- Never short-circuit the battery terminals.
- Non-rechargeable batteries are not to be recharged.
- Use only batteries of the same or equivalent type as recommended.
- Do not charge non-rechargeable batteries.
- Remove rechargeable batteries from the product before charging.
- If removable rechargeable batteries are used, they are only to be charged under adult supervision.

43

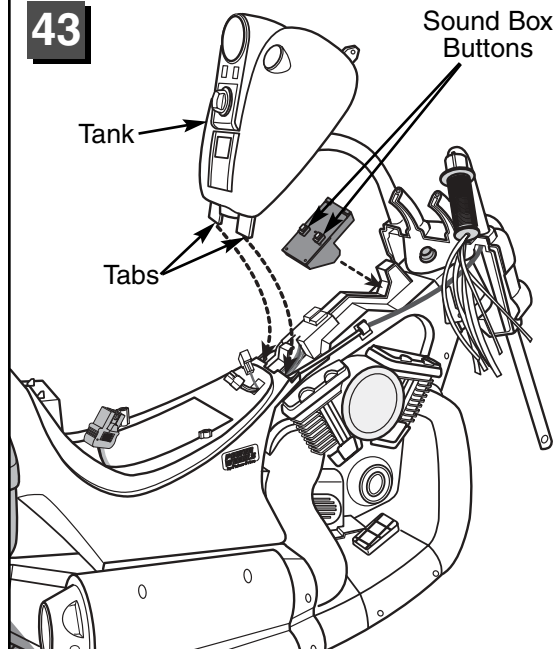

- Balance the sound box on the vehicle body. (The speaker should face down.)
- Fit the tabs at the bottom of the tank under the front end of the vehicle body.
- Lower the tank on the vehicle frame, making sure that the two small square openings in the tank fit over the buttons on the sound box.

44

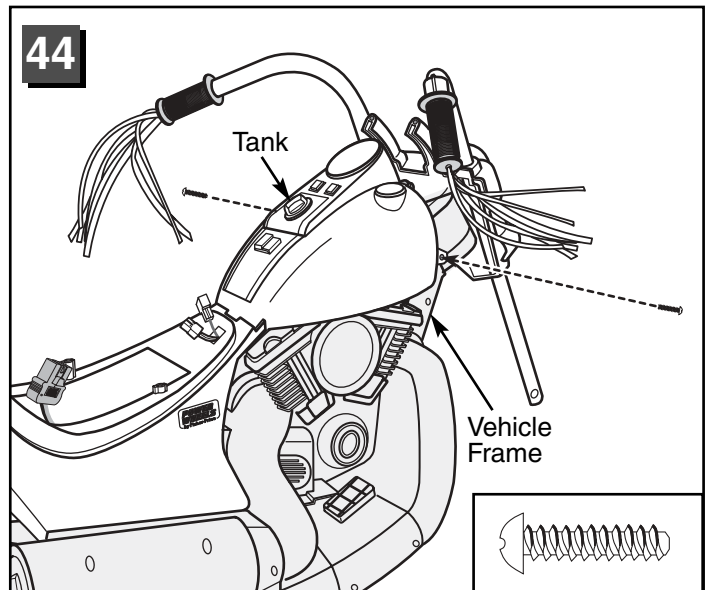

- Insert a #8 x 3/4" screw through the hole in each side of the tank and tighten.

Hint: To replace the batteries in the sound box, simply remove the screws from the tank and remove the tank from the vehicle frame. After replacing the batteries, be sure to replace the sound box, tank and screws.

Assembly

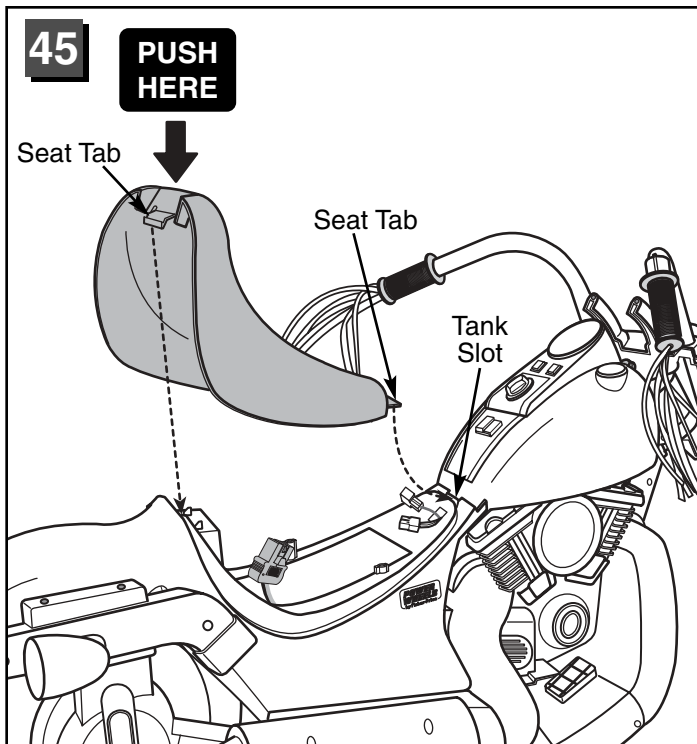

- Fit the tab on the front of the seat into the slot near the tank.
- Push down firmly near the back of the seat to “snap” it to the vehicle.

Hint: You will need to remove the seat to access the high speed connectors and to charge the 12 volt battery. To remove the seat, press the tab at the back of the seat and lift.

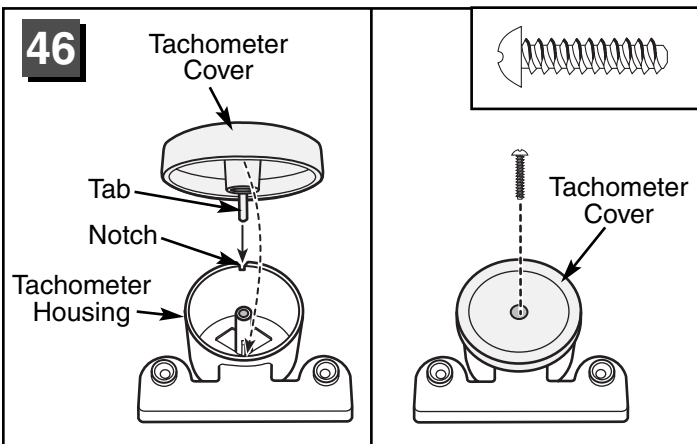

- Fit the tachometer cover onto the tachometer housing. The tab on the tachometer cover should fit into the notch in the tachometer housing.
- Insert a #8 x 3/4" screw into the tachometer cover and tighten.

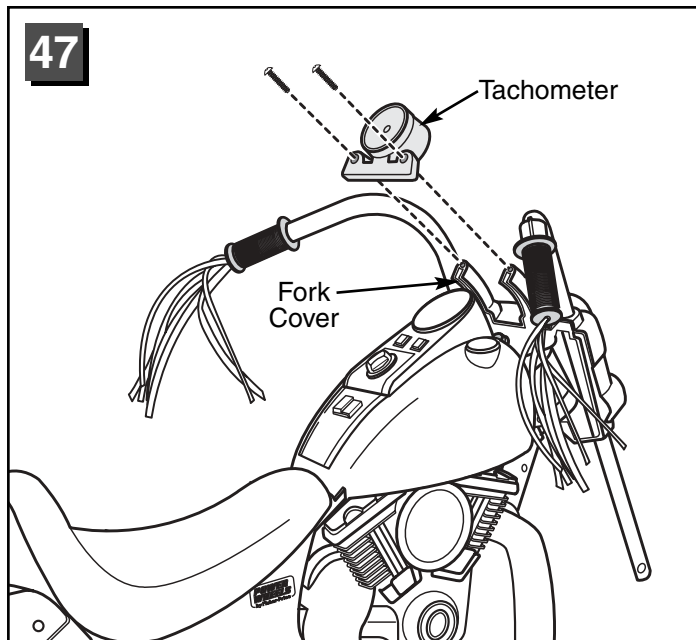

- Fit the tachometer to the fork cover.
- Insert two #8 x 3/4" screws into the tachometer and tighten.

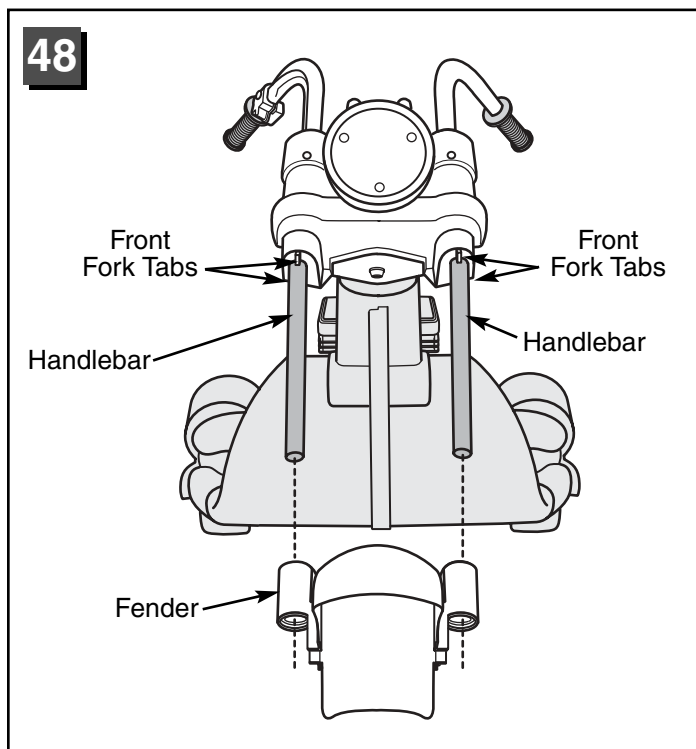

- Slide the fender onto the ends of the handlebars. Make sure the pegs on the fender slide over the tabs on the front fork.

Assembly

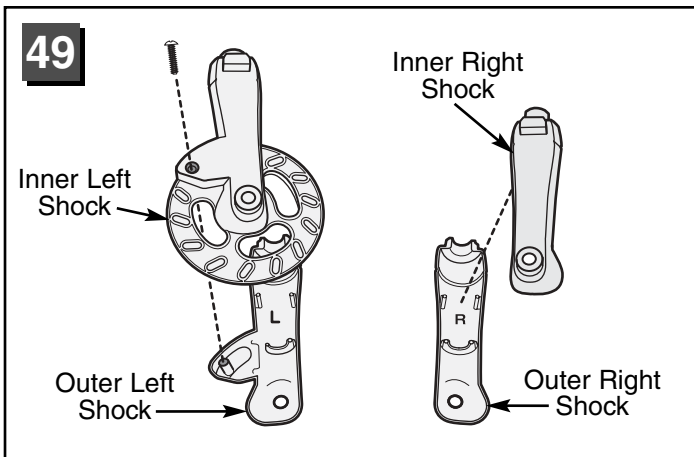

- The shock sets may be held together by rubber bands to aid in assembly. After completing assembly step 50, remove and throw away the rubber bands.
- Fit the inner and outer left shock halves together (they are labeled on the inside with an "L"). Insert a #8 x 3/4" screw into the hole in the outer left shock and tighten.
- Fit the inner and outer right shock halves together (they are labeled on the inside with an "R"). Hold the halves together until the next step.

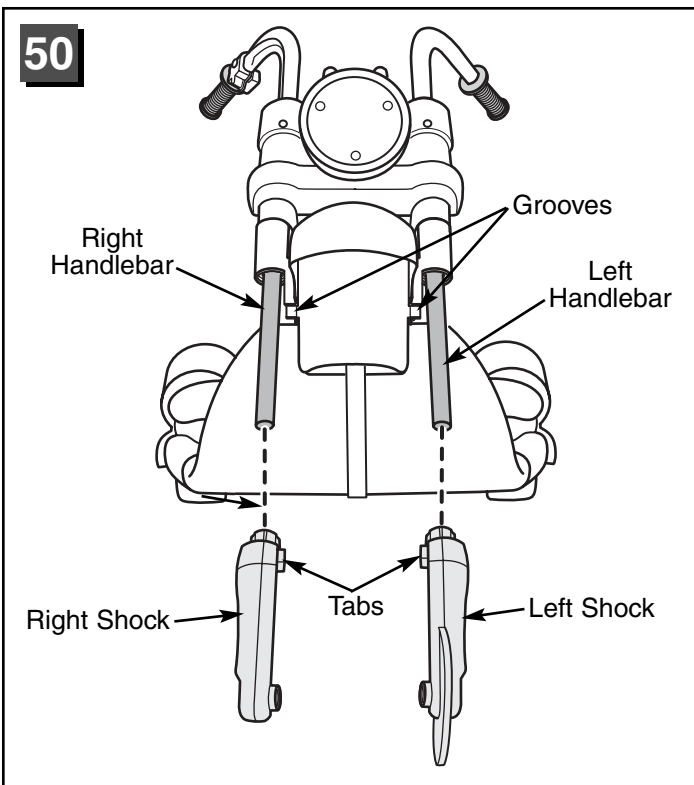

- Fit the right shock assembly onto the end of the right handlebar. Fit the left shock assembly onto the end of the left handlebar.
- Push firmly to slide the shocks onto the handlebars making sure that the tabs on the inner shock halves fit into the grooves in the fender.

Hint: You will need the help of another adult to hold the shocks and fender in place for the next two assembly steps.

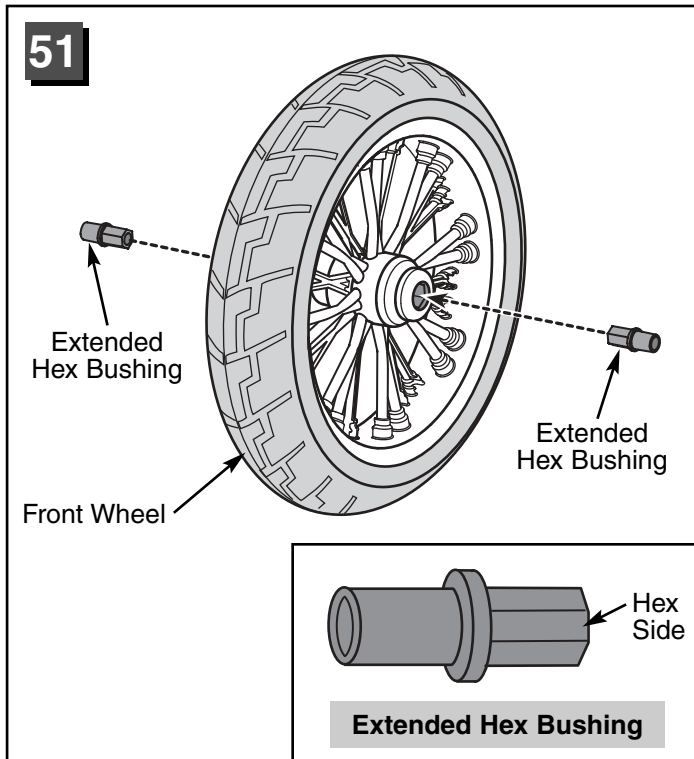

- Fit two extended hex bushings, *hex side first*, into the hole in the front wheel.

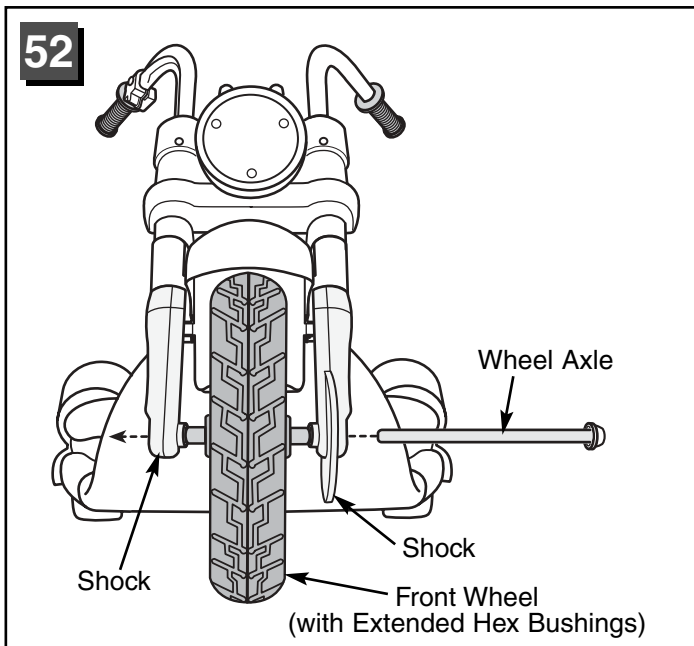

- While holding the extended hex bushings in place, position the front wheel between the shocks.
- Being careful to keep the shocks correctly positioned, align the holes in the shocks with the holes in the handlebars. Slide the remaining wheel axle (with .437 cap nut assembled in step 16) through one shock.

Hint: If the hole in the shock and handlebar are not aligned, the fender may not be properly positioned on the front fork. Reposition the fender to align the holes.

Assembly

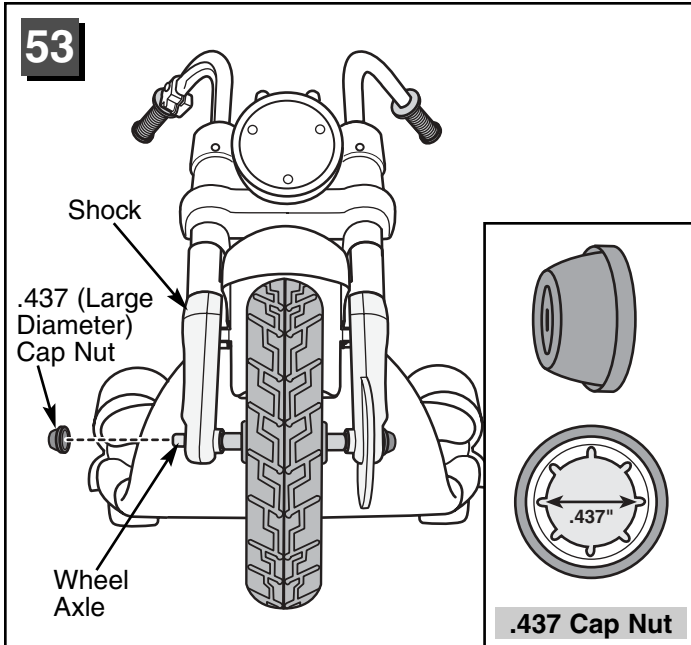

- Continue to slide the wheel axle through the extended hex bushing, wheel, extended hex bushing and then the shock.
- Fit a .437 (large diameter) cap nut on the end of the wheel axle.
- Support the opposite end of the wheel axle and tap the cap nut with a hammer to secure it on the end of the wheel axle.
- Pull on the .437 cap nut to make sure the front wheel assembly is secure.

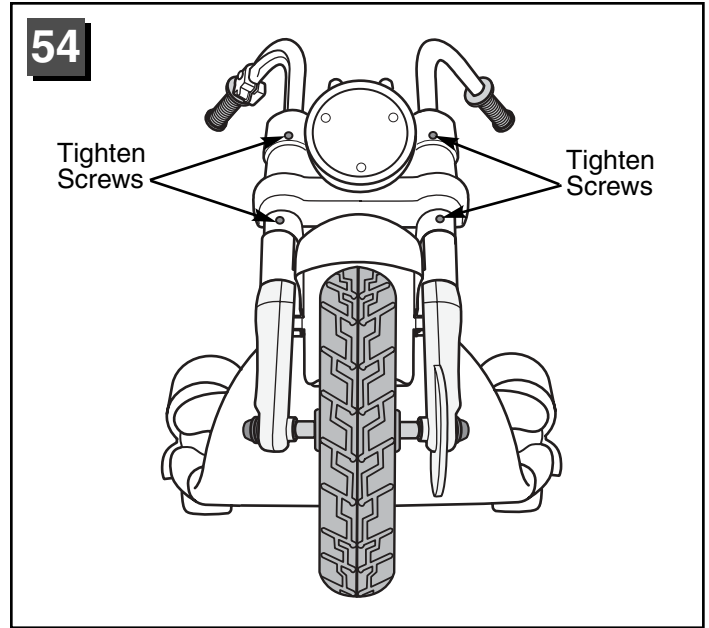

- Completely tighten the four screws in the front handlebar assembly to secure the handlebars.

Label Decoration - Model B3160

4

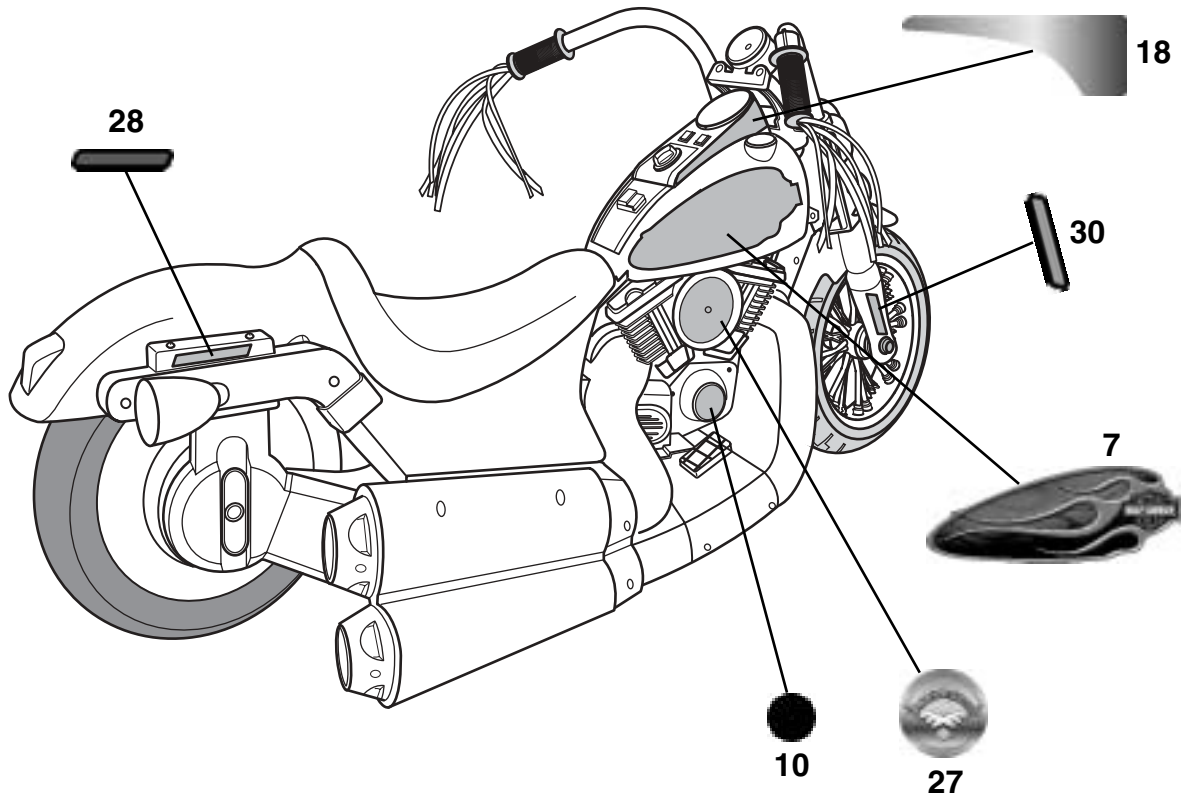

Right Side

5

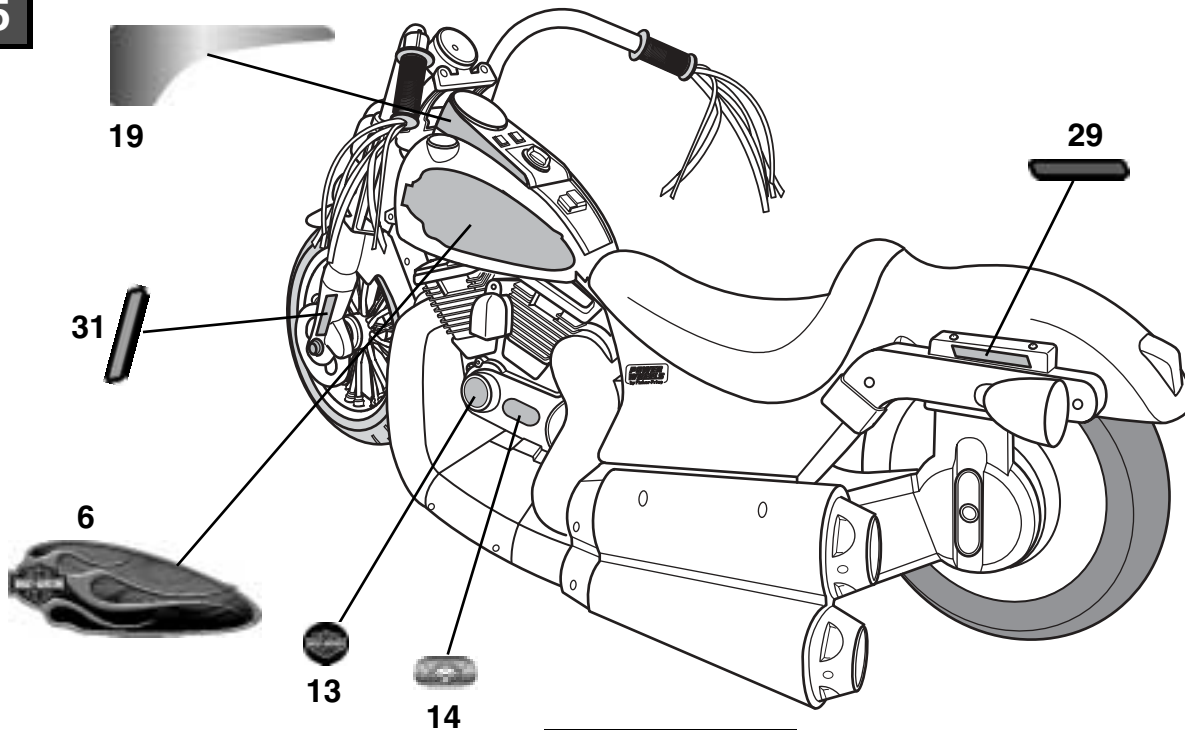

Left Side

Label Decoration - Model B9784

4

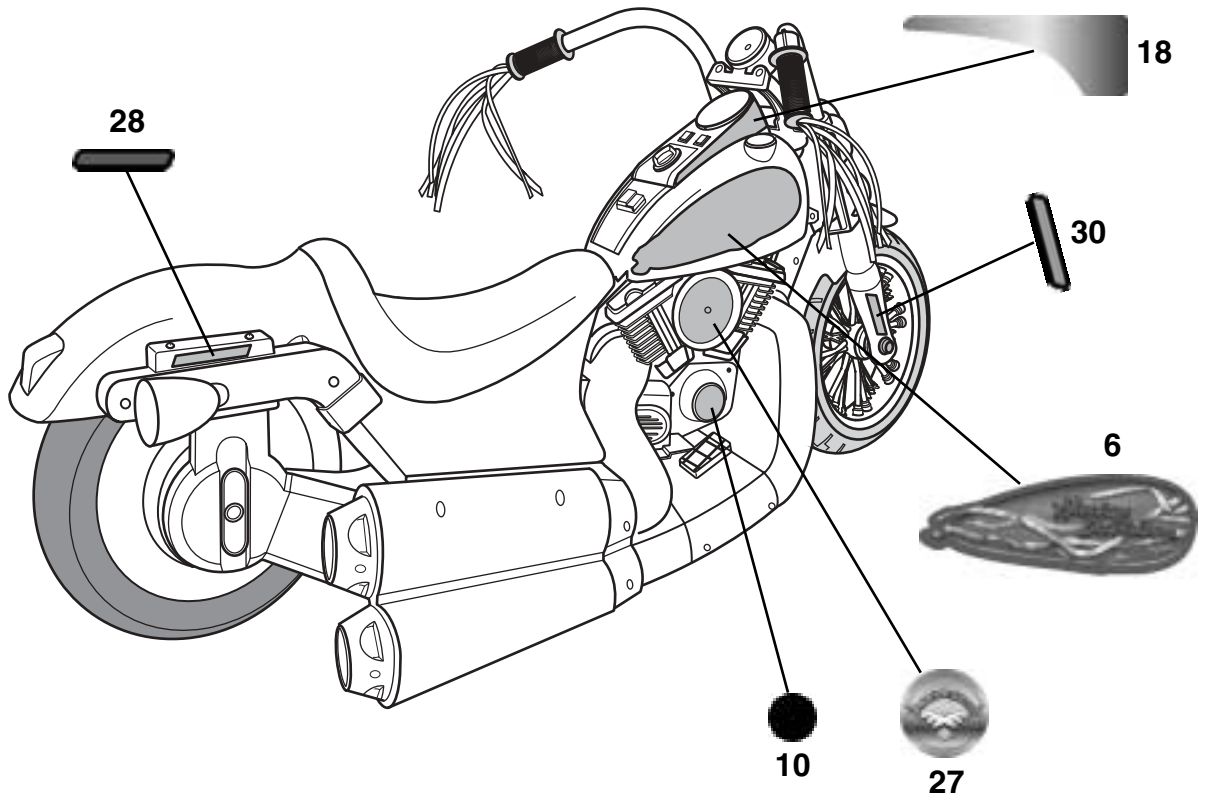

Right Side

5

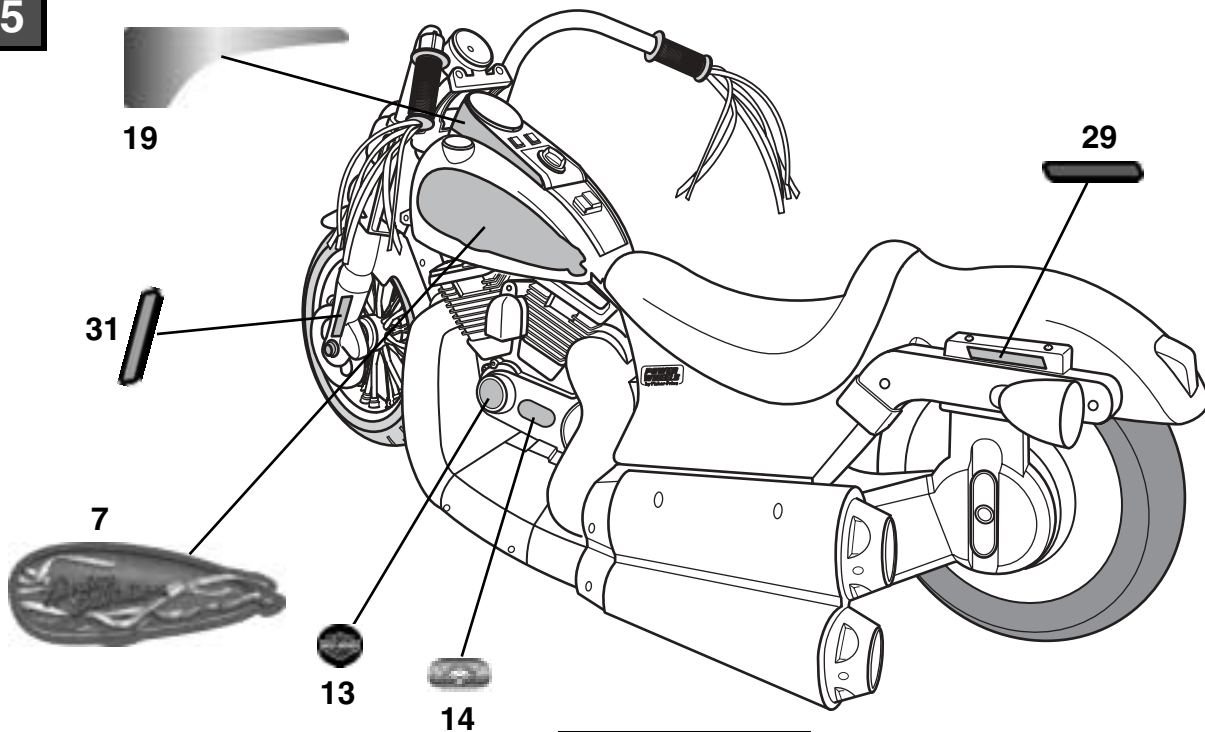

Left Side

H

Battery Installation

IMPORTANT! Use only Power Wheels® 12 volt battery. Use of any other battery will damage your vehicle. Make sure that you charge the battery for at least 18 hours using the enclosed Power Wheels® 12 volt charger **before operating your vehicle for the first time**. Charge the battery for at least 14 hours after each use of the vehicle. Never charge the battery longer than 30 hours. Failure to follow these instructions may damage your battery and will void your warranty.

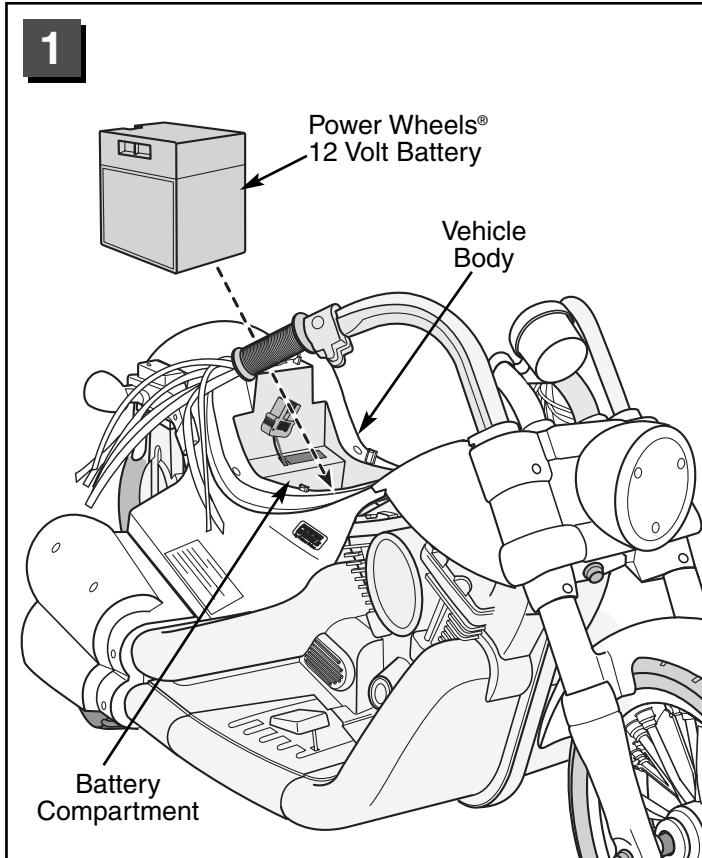

- Remove the seat. Press the tab at the back of the seat and lift.
- Place the Power Wheels® 12 volt battery upright in the battery compartment. **Make sure the battery terminals face the rear of the vehicle.**

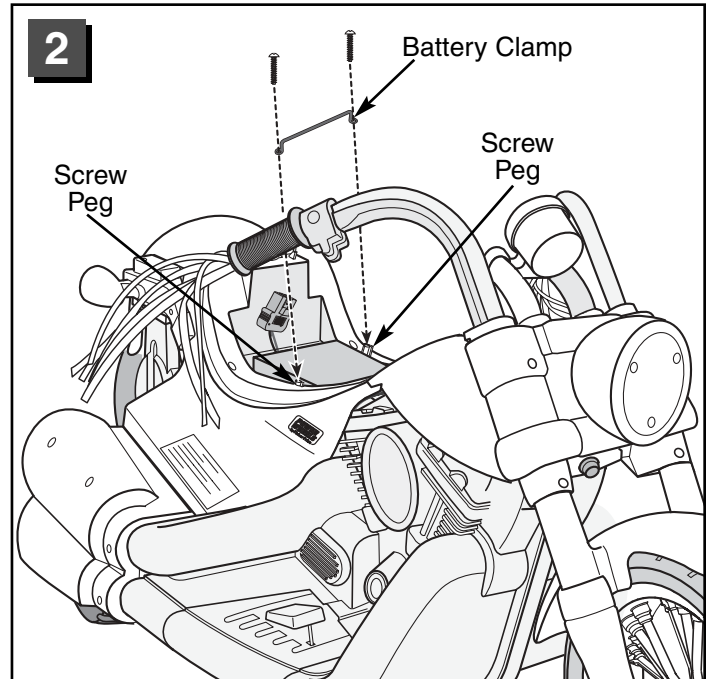

- Fit the battery clamp over the battery.
- Insert a screw through each end of the battery clamp and into the screw pegs in the vehicle body.
- Tighten the screws using a Phillips screwdriver. Do not over-tighten.

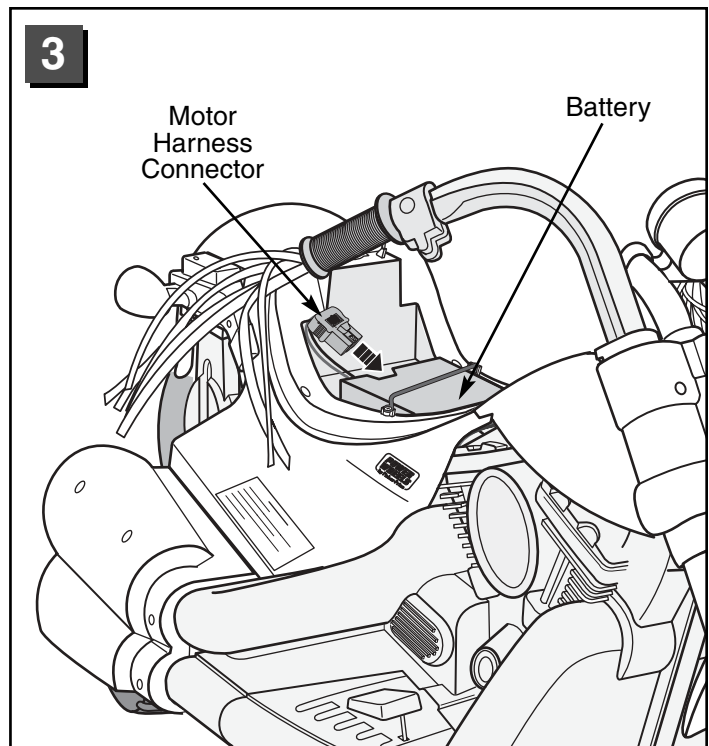

- Plug the motor harness connector into the battery. **Push firmly to make sure the connector is secure in the battery.**
- Replace the seat on the vehicle.

I

Battery Care and Disposal

Care

If a battery leak develops, avoid contact with the leaking acid and place the damaged battery in a plastic bag. See information below for proper disposal.

If acid comes in contact with skin or eyes, flush with cool water for at least 15 minutes and call a physician.

If acid is internally ingested, give water, milk of magnesia or egg whites immediately. Never give emetics or induce vomiting. Call a physician.

- Charge a new battery for at least 18 hours before first use. Never charge the battery longer than 30 hours. Overcharging or undercharging the battery may shorten battery life and decrease vehicle running time.
- After the first charge, recharge the battery for at least 14 hours after each use. Never charge the battery longer than 30 hours. Charge the battery after each use, regardless of how long the vehicle was used.
- The battery must be upright while charging.
- Do not allow the battery to run down completely before charging.
- Charge the battery before storing the vehicle.
- Charge the battery at least once per month, even if the vehicle has not been used.
- Leaving the battery in a discharged condition will ruin it.
- Always remove an exhausted battery from the vehicle. Battery leakage and corrosion can damage the vehicle.
- Do not store the battery on a surface (such as kitchen counter tops) which could be damaged by the acid contained inside the battery. Take precautions to protect the surface on which you store the battery.
- Do not store the battery in temperatures above 75° F or below -10° F.
- Use only a Power Wheels® 12 volt battery. Remember to charge the new battery for at least 18 hours before first use.
- Prevent the battery from moving freely inside the battery compartment. Always use the battery clamp to secure the battery in the battery compartment.
- Examine the battery, charger and their connectors for excessive wear or damage each time you charge the battery. If damage is detected, do not use the charger or the battery until you have replaced the worn or damaged part.

Battery Care and Disposal

Disposal



- Your Power Wheels® battery is sealed lead-acid battery. They must be recycled or disposed of in an environmentally sound manner.
- Do not dispose of a lead-acid battery in a fire. The battery may explode or leak.
- Do not dispose of a lead-acid battery in your regular, household trash. The incineration, landfilling or mixing of sealed lead-acid batteries with household trash is prohibited by law in most areas.
- Return an exhausted battery to a federal or state approved lead-acid battery recycler, such as a Power Wheels® authorized service center or a local seller of automotive batteries. For the authorized service center location nearest to you, please call **1-800-348-0751**. Contact your local waste management officials for other information regarding the environmentally sound collection, recycling and disposal of lead-acid batteries. If you live in the State of Florida or the State of Minnesota, it is prohibited by law for anyone to throw away lead-acid batteries in the municipal waste stream.

J

Caring For Your Vehicle

- Check all screws, cap nuts and their protective coverings regularly and tighten as required. Check plastic parts on a regular basis for cracks or broken pieces.
- During snowy or rainy weather, the vehicle should be stored inside or under a protective cover. Remember to charge the battery at least once per month while your vehicle is not in regular use.
- Avoid operating the vehicle in wet or snowy conditions, and do not spray the vehicle with a hose. Do not wash the vehicle with soap and water. Water or moisture in the motors or electrical switches can cause them to corrode, and could cause switch or motor failure.
- Avoid operating the vehicle on sand, loose dirt or gravel. Sand, loose dirt or gravel in the motors or electrical switches can cause them to jam, and could cause switch or motor failure.
- The vehicle can be wiped down with a soft, dry cloth. For a shiny finish, you can wipe plastic parts with a non-wax furniture polish applied to a soft-cloth. Do not use automotive wax. Do not use soap and water or spray the vehicle with a hose.
- To ensure that your vehicle stays in good operating order, we recommend that you periodically have your vehicle checked by a Power Wheels® authorized service center. For the location of the authorized service center nearest to you, visit us on-line at www.powerwheels.com or call **1-800-348-0751**.

RIDING HAZARD



WARNING

Prevent Injuries and Deaths

- Direct Adult Supervision Required.
- Keep Children Within Safe Riding Areas

These areas must be:

- away from swimming pools and other bodies of water to prevent drownings.
- generally level to prevent tipovers.
- away from steps, cars, driveways, roads and alleys.

Teach Safety Rules to Children

While children can quickly develop the skill necessary to drive this vehicle, it is important to remember that their judgment skills are still very immature. Unsupervised driving by children can lead to serious injury. Before children use this vehicle, an adult should carefully evaluate the driving area as well as the children's skill level and ability to drive this vehicle safely. Children are not always able to recognize or anticipate hazards, even when they have been taught about them. **THERE IS NO ACCEPTABLE SUBSTITUTE FOR DIRECT ADULT SUPERVISION.**

Teach appropriate safety rules to your child before allowing operation of this vehicle. These rules should also be reviewed with neighborhood children or other playmates who want to drive this vehicle.

Riding Rules

Make sure children know and follow these rules for safe driving:

1. Always sit on the seat.
2. Always wear shoes.
3. Only 1 (one) rider at a time. A child who is not sitting on the seat or who is standing on the vehicle could fall off, cause a tip-over or block the driver's view. A child could be seriously injured.
4. Do not allow any child to drive the vehicle in the street or near moving (motorized) vehicles.
5. Do not allow any child to drive near bodies of water (such as pools or creeks), obstructions (such as furniture, low tree limbs or play equipment), or drop-offs (such as stairs or decks).
6. Do not allow any child to drive the vehicle in the dark. A child could encounter unexpected obstacles and have an accident. Operate the vehicle only in the daytime or a well-lit area.
7. Do not allow your child to drive on sloped or inclined surfaces. **Restrict your child's driving to generally level ground ONLY!**
8. Do not allow your child to drive down or across a steep slope.
 - The vehicle may gain unsafe speed, even if the pedal is released to stop.
 - The vehicle may tilt and tip over.
 - The wheels could lose traction, causing the vehicle to slip.
9. Do not allow your child to drive up steep inclines. The motor may stop and the vehicle could roll backwards at an unsafe speed.
10. Never put anything near any moving parts. Rotating parts such as motors, gear boxes and wheels can snag fingers, hair, etc., causing serious injury. Do not allow operation of the vehicle when it is on its side or in an upside-down position.
11. Do not operate the vehicle near flammable vapors (gasoline, paint thinner, acetone, liquid wax, etc.). The vehicle's electrical switches, like most electrical switches, emit an internal spark when first turned on or turned off. The presence of flammable liquids or vapors could cause an explosion or a fire. Keep all flammable products in tightly sealed containers and away from the vehicle.
12. Do not allow a child to operate the vehicle without direct adult supervision. To prevent unsupervised use of the vehicle, disconnect the motor harness from the battery when the vehicle is not in use.

L

How to Operate Your Vehicle

IMPORTANT! As assembled, your vehicle is ready to roll in low speed (2½ mph, maximum). When your child is ready to drive the vehicle in high speed (5 mph, maximum), follow the instructions on this page to connect the high speed hook-up and use the power boost button.

Beginner Use - Low Speed

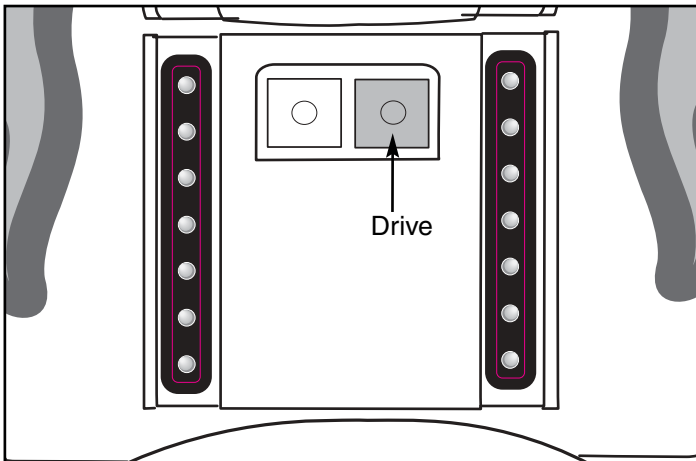

- Press the **DRIVE** button on the tank.
- Press the foot pedal. The vehicle drives forward at a maximum of 2½ mph.
- Help your child practice steering to learn how far and how quickly to turn the handlebar when driving forward in low speed.

To Back Up

IMPORTANT! To prevent damaging the motors and gears, teach your child to **stop the vehicle before switching direction**. Never shift from drive to reverse, or from reverse to drive, without stopping.

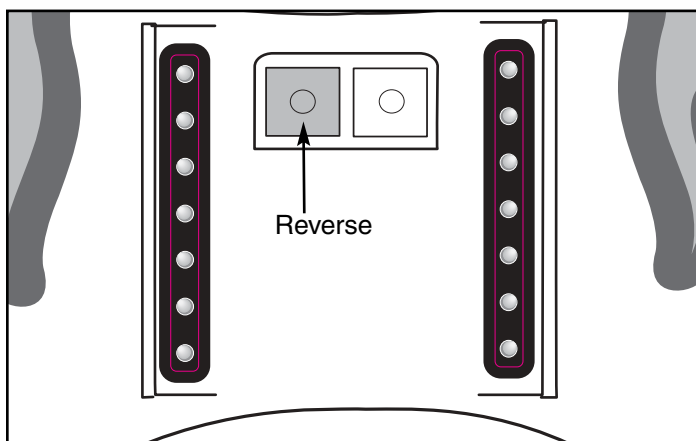

- Press the **REVERSE** button on the tank.
- Press the foot pedal. The vehicle backs-up at a maximum of 2½ mph.

Note: The vehicle is designed to operate in low speed only in reverse.

- Help your child practice steering to learn how far and how quickly to turn the handlebar when driving in reverse.

To Stop

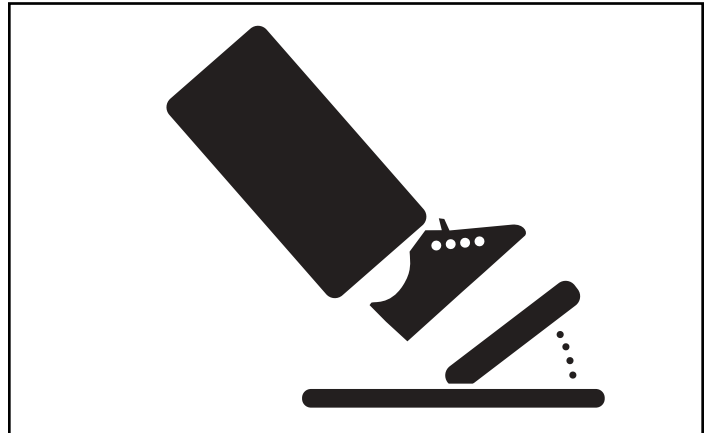

- Your vehicle has a patented, electronic braking system that automatically stops the vehicle when your child's foot is lifted from the pedal.
- Make sure your child is comfortable with steering the vehicle and automatically knows how to stop.

Advanced Use - High Speed

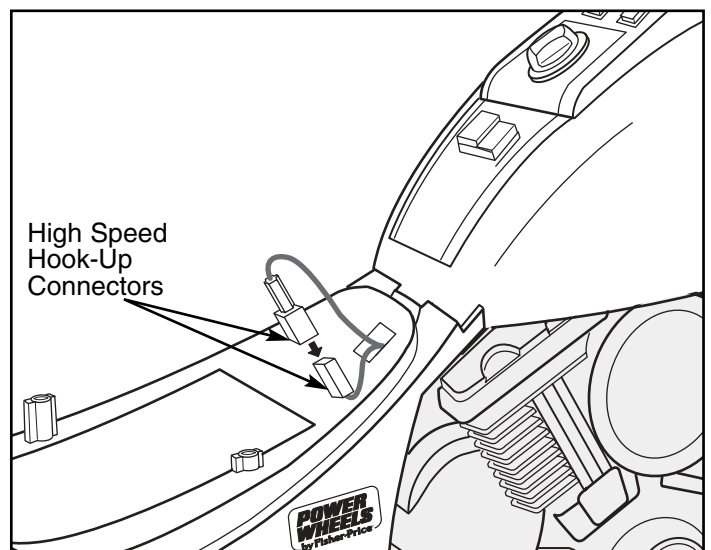

- Remove the vehicle seat to access the high speed hook-up.
- Plug the two high speed hook-up connectors together. Make sure the two connectors are completely joined.
- Re-assemble the vehicle seat.
- To prevent operation of the vehicle in high-speed, simply disconnect the high speed hook-up connectors.

How to Operate Your Vehicle

Advanced Use - High Speed

IMPORTANT! Your child should not drive the vehicle in **HIGH SPEED** from a stopped position. Always start in **LOW SPEED**. Then, press the power boost button to shift to **HIGH SPEED**.

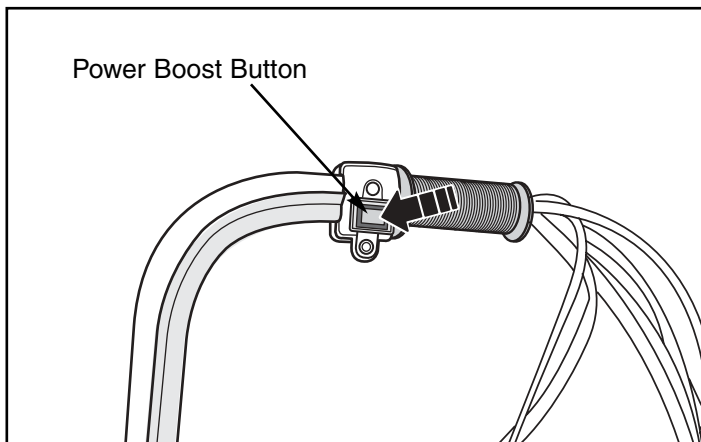

- Press the power boost button to shift the vehicle into high speed. The vehicle moves forward at a maximum of 5 mph.
- Help your child practice steering to learn how far and how quickly to turn the handlebar when driving forward in high speed.

M

FCC Statement (United States Only)

This equipment has been tested and found to comply with the limits for a Class B digital device, pursuant to part 15 of the FCC rules. These limits are designed to provide reasonable protection against harmful interference in a residential installation. This equipment generates, uses and can radiate radio frequency energy and, if not installed and used in accordance with the instructions, may cause harmful interference to radio communications. However, there is no guarantee that interference will not occur in a particular installation. If this equipment does cause harmful interference to radio or television reception, which can be determined by turning the equipment off and on, the user is encouraged to try to correct the interference by one or more of the following measures:

- Reorient or relocate the receiving antenna.
- Increase the separation between the equipment and receiver.
- Connect the equipment into an outlet on a circuit different from that to which the receiver is connected.
- Consult the dealer or an experienced radio/TV technician for help.

Note: Changes or modifications not expressly approved by the manufacturer responsible for compliance could void the user's authority to operate the equipment.

N

Bumper-to-Bumper* Limited Warranty

***One year limited warranty from the date of purchase on the Power Wheels® vehicle.**

Six month limited warranty on the 12 volt battery.

For the original purchaser, this one year limited warranty covers the Power Wheels® ride-on vehicle (purchased from Power Wheels®) against defects in materials and workmanship. The six month limited warranty applies only to the 12 volt battery included by Power Wheels® with the original purchase of the vehicle.

This warranty covers normal use and does not cover the Power Wheels® vehicle or battery if damaged by unreasonable use, neglect, accident, abuse, misuse, improper service or other causes not arising out of defects in materials or workmanship. Evidence of any attempt at consumer repair will void this warranty. This warranty does not cover, and is intended to exclude, any liability on the part of Power Wheels®, whether under this warranty or implied by law or any indirect or consequential damages for breach of warranty. Some states do not allow the exclusion or limitation so this limitation may not apply to you.

Should you need service or assistance with your vehicle during the warranty period, **do not return the vehicle to the store.** Power Wheels® has provided a nationwide network of authorized service centers. For a list of authorized service centers, please visit us on-line at www.powerwheels.com. Power Wheels® is continually expanding our Authorized Service Center Network. If there is not an authorized service center in your area, please call Consumer Relations for information, **1-800-348-0751**.

THIS WARRANTY GIVES YOU SPECIFIC LEGAL RIGHTS, AND YOU MAY ALSO HAVE OTHER RIGHTS WHICH MAY VARY FROM STATE TO STATE.

PLEASE SAVE YOUR ORIGINAL SALES RECEIPT.

O

Problems and Solutions Guide

IMPORTANT! If you experience a problem with your vehicle, first check the Problems and Solutions Guide below. If you still experience a problem, please contact Power Wheels® Consumer Relations, toll-free at **1-800-348-0751** between 8 AM and 6 PM (EST) Monday through Friday. Or, contact your local Power Wheels® authorized service center. For the location nearest to you, please visit us on-line at www.powerwheels.com or call **1-800-348-0751**.

Problem	Possible Cause	Solution
Vehicle does not run	Undercharged battery	Charge the battery. A new battery should have been charged for at least 18 hours before using the vehicle for the first time. After first-time use, recharge the battery for at least 14 hours after each use. Never charge the battery longer than 30 hours.
		Check all connectors. Make sure the battery connector is tightly plugged into the battery, and that the charger is plugged into the wall.
		Make sure power flow to the wall outlet is "ON".
	Charger is not working	There is no sure way to tell if your charger is working unless you have a volt meter. If you suspect there is a problem with your charger, contact your local Power Wheels® authorized service center. They can test your charger for you.
	Tripped thermal fuse	Each Power Wheels® 12 volt battery has a built-in thermal fuse. A thermal fuse may "trip" and shut down operation of the vehicle if the vehicle is overloaded or the driving conditions too severe. The fuse will automatically reset itself after approximately 25 seconds, allowing the vehicle to resume normal operation. To avoid repeated automatic shutdowns, do not overload the vehicle by exceeding the 65 lb maximum weight capacity or by towing anything behind the vehicle. Do not drive up hills or run into fixed objects, which can cause the wheels to stop spinning while power is still being supplied to the motors. If a thermal fuse continually trips, contact your local Power Wheels® authorized service center.
	Loose wire or loose connectors	Check all wires and connectors. Make sure the motor harness connector is tightly plugged into the battery and that there are no loose wires around the motors.
	Dead batteries	If your battery is old or if you have not followed Battery Care instructions, your battery may be dead. If you are unsure whether or not the battery are dead, you can have them tested at your local Power Wheels® authorized service center.
	Electrical switch damage	The electrical switches can become corroded due to exposure to water or moisture, or can jam due to loose dirt, sand or gravel. Contact your local Power Wheels® authorized service center for diagnosis and repair.
Motor damage	Contact your local Power Wheels® authorized service center for diagnosis and repair.	

Problems and Solutions Guide

Problem	Possible Cause	Solution
Vehicle was running but suddenly stopped	Loose wire or loose connectors	Check all wires and connectors. Make sure the motor harness connector is tightly plugged into the battery, and that there are no loose wires around the motors.
	Tripped thermal fuse	Each Power Wheels® 12 volt battery has a built-in thermal fuse. A thermal fuse may "trip" and shut down operation of the vehicle if the vehicle is overloaded or the driving conditions too severe. The fuse will automatically reset itself after approximately 25 seconds, allowing the vehicle to resume normal operation. To avoid repeated automatic shutdowns, do not overload the vehicle by exceeding the 65 lb maximum weight capacity or by towing anything behind the vehicle. Do not drive up hills or run into fixed objects, which can cause the wheels to stop spinning while power is still being supplied to the motors. If a thermal fuse continually trips, contact your local Power Wheels® authorized service center.
Short run time (Less than 1 - 3 hours per charge)	Undercharged battery	Charge the battery. A new battery should have been charged for at least 18 hours before using the vehicle for the first time. After first-time use, recharge the battery for at least 14 hours after each use. Never charge the battery longer than 30 hours.
		Check all wires and connectors. Make sure the charger connector is tightly plugged into the battery, and that the charger is plugged into the wall.
		Make sure power flow to the wall outlet is "ON".
	Overcharged battery	Do not charge the battery longer than 30 hours. If you suspect that your battery is damaged as a result of overcharging, contact your local Power Wheels® authorized service center. They can test the battery for you.
	Battery is old and will not accept full charge	Even with proper care, a rechargeable battery does not last forever. Average battery life is 1 to 3 years depending on vehicle use and use conditions. Replace only with Power Wheels® 12 volt battery with built-in thermal fuse. Do not substitute parts.
Tripped thermal fuse	Each Power Wheels® 12 volt battery has a built-in thermal fuse. A thermal fuse may "trip" and shut down operation of the vehicle if the vehicle is overloaded or the driving conditions too severe. The fuse will automatically reset itself after approximately 25 seconds, allowing the vehicle to resume normal operation. To avoid repeated automatic shutdowns, do not overload the vehicle by exceeding the 65 lb maximum weight capacity or by towing anything behind the vehicle. Do not drive up hills or run into fixed objects, which can cause the wheels to stop spinning while power is still being supplied to the motors. If a thermal fuse continually trips, contact your local Power Wheels® authorized service center.	
	Each Power Wheels® 12 volt battery has a built-in thermal fuse. A thermal fuse may "trip" and shut down operation of the vehicle if the vehicle is overloaded or the driving conditions too severe. The fuse will automatically reset itself after approximately 25 seconds, allowing the vehicle to resume normal operation. To avoid repeated automatic shutdowns, do not overload the vehicle by exceeding the 65 lb maximum weight capacity or by towing anything behind the vehicle. Do not drive up hills or run into fixed objects, which can cause the wheels to stop spinning while power is still being supplied to the motors. If a thermal fuse continually trips, contact your local Power Wheels® authorized service center.	
Vehicle runs sluggishly	Undercharged battery longer than 30 hours.	Charge the battery. A new battery should have been charged for at least 18 hours before using the vehicle for the first time. After first-time use, recharge the battery for at least 14 hours after each use. Never charge the battery
		Check all connectors. Make sure the charger connector is tightly plugged into the battery, and that the charger is plugged into the wall.
		Make sure power flow to the wall outlet is "ON".

Problems and Solutions Guide

Problem	Possible Cause	Solution
Vehicle runs sluggishly (cont.)	Battery needs charging	Be sure to charge the battery after each use.
	Battery is old and will not accept full charge	Even with proper care, a rechargeable battery does not last forever. Average battery life is 1 to 3 years depending on vehicle use and use conditions. Replace only with Power Wheels® 12 volt batteries with built-in thermal fuse. Do not substitute parts.
	Vehicle is overloaded	Make sure you do not overload the vehicle by allowing more than 1 rider at one time, exceeding the 65 lb. maximum weight capacity, or by towing objects behind the vehicle. If the vehicle is overloaded, the fuses in the batteries may "trip", and automatically shut down operation of the for approximately 25 seconds. Adjust the driving conditions to prevent repeated automatic shutdowns.
	Driving conditions are too stressful	Use only on generally level ground.
Vehicle runs in low speed but does not run in high speed Note: The vehicle is designed to operate in low speed only in reverse.	High speed hook-up not connected	The vehicle was pre-set to operate only in low speed until you connect the high speed hook-up. Follow the instructions on page 30 to connect High Speed Hook-up. Note: The power boost button will not operate until the high-speed connectors are joined.
Sometimes the vehicle doesn't run, but other times it does	Loose wire or connector	Check all wires around the motors and all connectors to make sure they are tight.
	Motor or electrical switch damage	Contact your local Power Wheels® authorized service center for diagnosis and repair.
When the foot pedal is pressed, the vehicle won't run without a push	Loose wire or connector	Check all wires around the motors and all connectors to make sure they are tight.
	"Dead Spot" on motor	Contact your local Power Wheels® authorized service center for diagnosis and repair.
Battery's thermal fuse constantly "trips", but the vehicle is not overloaded nor the driving conditions too severe	Damaged battery	Contact your local Power Wheels® authorized service center for diagnosis and repair.
	Child is switching between FORWARD and REVERSE without stopping	Teach your child to stop the vehicle before switching direction.
Loud clacking or grinding noise from a motor-gearbox	Broken gears	Contact your local Power Wheels® authorized service center for diagnosis and repair.
Charger gets warm during use	It is normal for some chargers to get warm during use and is not reason for concern. Some chargers do not get warm during use.	No action required.
		If your charger does not get warm during use, it does not mean that it is not working properly.
Battery makes a sizzling or gurgling noise when charging	It is normal for some batteries to make noise and swell slightly while charging and is not reason for concern. Some batteries do not make noise or swell while charging.	No action required.
		If your battery does not make noise or swell slightly during charging, it does not mean that it is not accepting the charge.

IMPORTANT!

DO NOT use this vehicle for the first time until you have charged the battery for 18 hours.

Remember to...

- ✓ Charge the battery immediately after each use.
- ✓ Charge the battery once a month during storage, even if the vehicle has not been used.

Failure to follow these instructions will permanently damage your battery and void your warranty. Please refer to the Battery Care Section in this manual for more information. For high speed operation, please refer to the "How to Operate Your Vehicle Section" in this manual for more information.

DO NOT Return your Vehicle to the Store!



Over 400
Authorized Service Centers!
Visit us on-line at
www.powerwheels.com for
the location nearest you.

If you are missing parts or need assistance,
please call us toll-free:

Power Wheels® Consumer Relations

1-800-348-0751

8 AM - 6 PM EST, Monday through Friday.



Or contact your local, **independently owned and operated**
Power Wheels® Authorized Service Center.
For the location nearest you,
visit us on-line at www.powerwheels.com.

Fisher-Price and Power Wheels by Fisher-Price are U.S. trademarks of Mattel, Inc.
Fisher-Price, Inc., a subsidiary of Mattel, Inc., East Aurora, New York 14052 U.S.A.
©2003 Mattel, Inc. All Rights Reserved.