

This Owner's Manual is provided and hosted by [Appliance Factory Parts](#).



FISHER PRICE C2390 Owner's Manual

[Shop genuine replacement parts for FISHER PRICE
C2390](#)



[Find Your FISHER PRICE Ride On Parts - Select From 999 Models](#)

----- Manual continues below -----

Jeep[®] WRANGLER



Product features may vary from the picture above.

Please read this manual and save it with your original sales receipt.

Tools needed for assembly: Phillips Screwdriver, Hammer, Pliers
and Safety Scissors (tools not included).

Use only with a Power Wheels[®] 12 Volt Lead-Acid Rechargeable Battery and Power Wheels[®]
12 Volt Charger with Type "12V" Connector (included).

JEEP and the Jeep grille design are registered trademarks of DaimlerChrysler Corporation and are used under license. ©DaimlerChrysler Corporation 2003. Goodyear (and winged foot design) and Wrangler (for tires) are trademarks of The Goodyear Tire & Rubber Company, used with permission.

www.powerwheels.com



Owner's Manual with Assembly Instructions

For Model C2390

Table of Contents

A	Important Information	.2
B	Warnings and Cautions	.3
C	Parts	.4
D	Parts Diagram	.6
E	Battery Charging	.7
F	Assembly	.8
G	Label Decoration	.16
H	Battery Installation	.18
I	Battery Care and Disposal	.19
J	Rules for Safe Driving	.20
K	How to Operate Your Vehicle	.21
L	Caring for Your Vehicle	.22
M	Problems and Solutions Guide	.23
N	Limited Warranty	.26

A

Important Information

- Your new vehicle requires adult assembly. Please set aside at least 60 minutes for assembly.
- You must charge your battery for 18 - 30 hours **before you use your vehicle for the first time**. We recommend that you start charging your battery before beginning assembly. Please see Battery Charging beginning on page 7 for detailed instructions.
- Read this manual carefully for important safety information and operating instructions before using your vehicle. Keep these instructions for future reference as they contain important information.
- This vehicle is designed for use on: grass, asphalt or other hard surfaces; on generally level terrain; by children 3 years of age and up.
- Make sure children know and follow these rules for safe driving and riding:
 - always sit in the seat.
 - always wear shoes.
 - only two (2) riders at a time.
- Use this vehicle **ONLY** outdoors. Most interior flooring can be damaged by riding this vehicle indoors. Fisher-Price® will not be responsible for damage to the floor if the vehicle is used indoors.
- This vehicle has adjustable play seat belts. Please note that the adjustable seat belts are designed to be a play feature only and do not function as protective safety restraints.
- To prevent damaging the motors and gears, teach your child to stop the vehicle before switching between forward and reverse. Do not tow anything behind the vehicle or overload it. Do not exceed the maximum weight capacity of 130 lb. (59 kg).
- For safety reasons, your vehicle has been pre-set so that it will only operate at low speed. **You must remove the high speed lock-out screw to allow operation of the vehicle at high speed**. Please see page 22 for detailed instructions.
- If you have any questions about your Power Wheels® vehicle, please call our toll-free service lines at **1-800-348-0751** from 8 AM to 6 PM (EST) Monday through Friday. Trained customer service representatives are available to take your call in English or French. Habla Español? Si usted tiene alguna pregunta ó necesita asistencia llame gratis **1-800-348-0755** para los Estados Unidos. Tenemos representantes que hablan español para atender su llamada.
- For your convenience, Power Wheels® maintains an **independently owned and operated** Authorized Service Center Network with more than 400 authorized service centers nationwide. The authorized service centers will repair or replace parts under warranty at no extra charge, and can perform non-warranty repairs for a minimal charge. To find the authorized service center nearest to you, visit us on-line at **www.powerwheels.com** or call **1-800-348-0751**.
- If you would like to register your vehicle, please visit us on-line at **www.powerwheels.com**.

ELECTRICAL HAZARD **WARNING**

- Battery can fall out and injure a child if vehicle tips over. Always use battery clamp.
- **PREVENT FIRE**
 - Never modify the electrical system. Alterations could cause a fire resulting in serious injury and could also ruin the electrical system.
 - Use of the wrong type battery or charger could cause a fire or explosion resulting in serious injury.
 - Use of Power Wheels® components in products other than Power Wheels® vehicles could cause overheating, fire or explosion.
- The battery must be handled by adults only. The battery is heavy and contains sulfuric acid (electrolyte). Dropping the battery could result in serious injury.
- Never allow children to charge the battery. Battery charging must be done by adults only. A child could be injured by the electricity involved in charging the battery.
- Never lift or carry the battery by the wires or connector. This can damage the battery and possibly cause a fire resulting in serious injury. Lift and carry the battery by the case only.
- Read the safety instructions on the battery.
- Examine the battery, charger and their connectors for excessive wear or damage each time you charge the battery. If damage or excessive wear is detected, do not use the charger or the battery until you have replaced the worn or damaged part.
- **HOT** motors. Handle carefully.

RIDING HAZARD **WARNING**

- **Prevent Injuries and Deaths**
 - Direct Adult Supervision Required
 - Keep Children Within Safe Riding Areas.
These areas must be:
 - away from swimming pools and other bodies of water to prevent drownings
 - generally level to prevent tipovers
 - away from steps, driveways, cars, roads and alleys.

 **CAUTION**

- In the unassembled state, this package contains small parts. Adult assembly is required.
- Use the charger in dry locations only.

C

Parts

- If you experience a problem with this product, or are missing a part, please call us at **1-800-348-0751**, rather than return this product to the store.
- Please identify all parts before assembly and save all packaging material until assembly is complete to ensure that no parts are discarded.
- Metal parts have been coated with a lubricant to protect them during shipment. Wipe all metal parts with a paper towel to remove any excess lubricant.

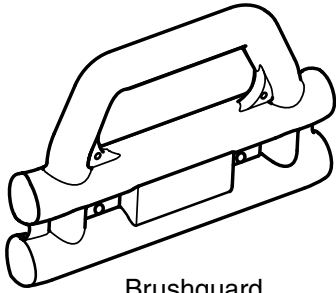

Brushguard

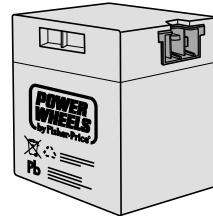

12 Volt Battery

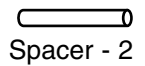

Spacer - 2

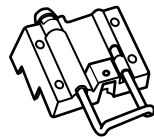

Battery Clamp Unit

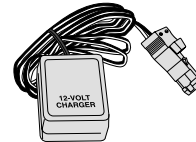

12 Volt Charger

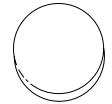

Light Cover - 2

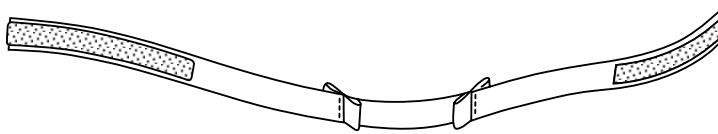

Long Seat Belt Strap

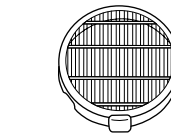

Headlight Lens - 2

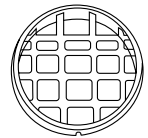

Lens Guard - 2



Short Seat Belt Strap - 2

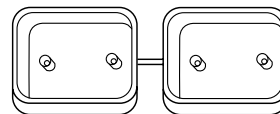

Taillight Housing Set

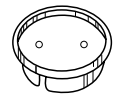

Steering Wheel Cap

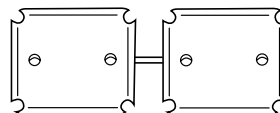

Taillight Lens Set



Cap

Parts

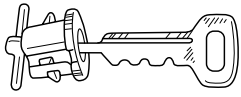

Key Assembly



Hood Latch - 2



#8 x 4" Screw - 2



#8 x 1" Screw - 7



#10 x 1/2" Screw - 8



#10 x 1" Screw - 7

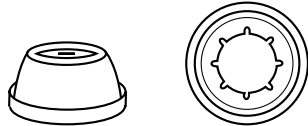

.354 Cap Nut - 2



#8 Lock Nut - 2



#8-32 x 1.625" Screw - 2

All Shown Actual Size

*For your convenience, an extra .354 cap nut, #8 x 1", #10 x 1/2" and #10 x 1" fasteners are included.



Steering Column

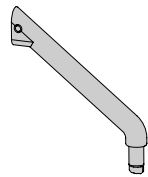

Sport Bar Support - 2

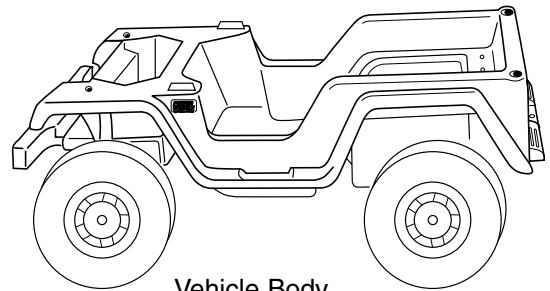

Vehicle Body

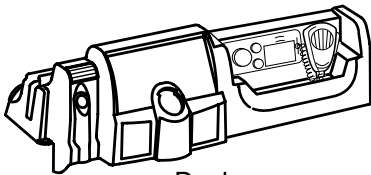

Dash

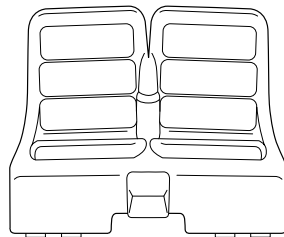

Seat

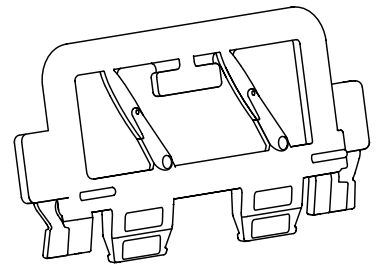

Windshield



Steering Wheel

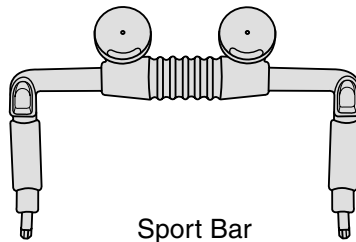

Sport Bar

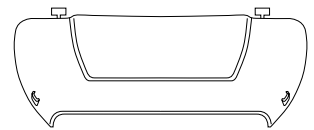

Hood

Not Shown: Label Sheet

D

Parts Diagram

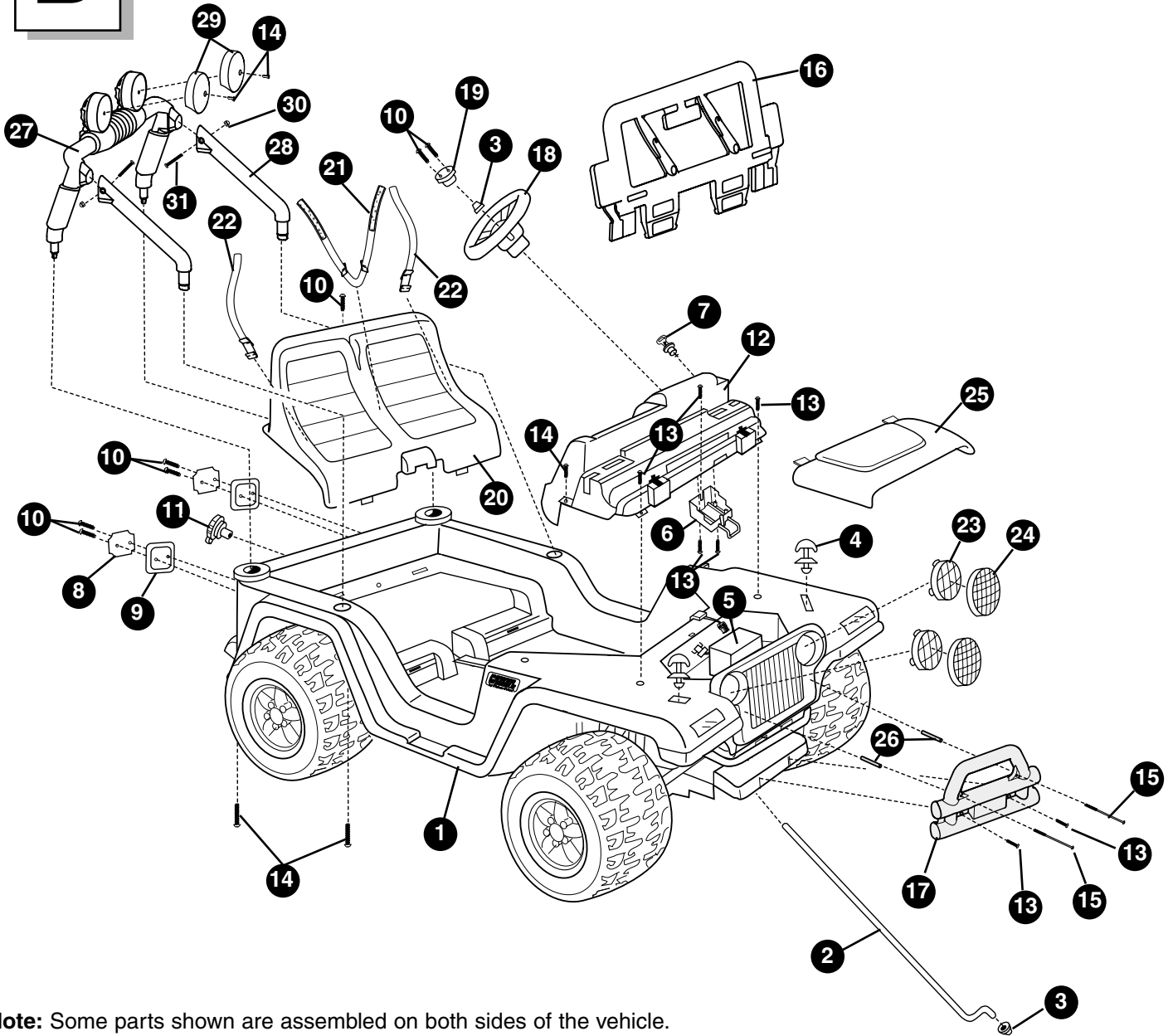

Note: Some parts shown are assembled on both sides of the vehicle.

No.	Part	Quantity	No.	Part	Quantity	No.	Part	Quantity
1	Vehicle Body	1	13	#10 x 1" Screw	7	25	Hood	1
2	Steering Column	1	14	#10 x 1/2" Screw	8	26	Spacer	2
3	.354 Cap Nut	2	15	#8 x 4" Screw	2	27	Sport Bar	1
4	Hood Latch	2	16	Windshield	1	28	Sport Bar Support	2
5	12 Volt Battery	1	17	Brushguard	1	29	Light Cover	2
6	Battery Clamp Unit	1	18	Steering Wheel	1	30	Lock Nut	2
7	Key Assembly	1	19	Steering Wheel Cap	1	31	#8-32 x 1.625" Screw	2
8	Taillight Lens	2	20	Seat	1			
9	Taillight Housing	2	21	Long Seat Belt Strap	1			
10	#8 x 1" Screw	7	22	Short Seat Belt Strap	2			
11	Cap	1	23	Headlight Lens	2			
12	Dash	1	24	Lens Guard	2			

ELECTRICAL HAZARD **WARNING**

- Battery can fall out and injure a child if vehicle tips over. Always use battery clamp.
- **PREVENT FIRE**
 - Never modify the electrical system. Alterations could cause a fire resulting in serious injury and could also ruin the electrical system.
 - Use of the wrong type battery or charger could cause a fire or explosion resulting in serious injury.
 - Use of Power Wheels® components in products other than Power Wheels® vehicles could cause overheating, fire or explosion.
- The battery must be handled by adults only. The battery is heavy and contains sulfuric acid (electrolyte). Dropping the battery could result in serious injury.
- Never allow children to charge the battery. Battery charging must be done by adults only. A child could be injured by the electricity involved in charging the battery.
- Never lift or carry the battery by the wires or connector. This can damage the battery and possibly cause a fire resulting in serious injury. Lift and carry the battery by the case only.
- Read the safety instructions on the battery.
- Examine the battery, charger and their connectors for excessive wear or damage each time you charge the battery. If damage or excessive wear is detected, do not use the charger or the battery until you have replaced the worn or damaged part.

 **CAUTION**

Use the charger in dry locations only.

About Thermal Fuses

Your Power Wheels® 12 volt battery is equipped with a built-in thermal fuse. The thermal fuse is a self-resetting safety device which automatically “trips” and shuts down operation of the vehicle if the vehicle is overloaded or the driving conditions too severe. Once a fuse has “tripped”, it will automatically reset itself after approximately 25 seconds and allow the vehicle to resume normal operations. To avoid repeated automatic shutdowns, do not overload the vehicle by exceeding the 130 lb. (59 kg). maximum weight capacity or by towing anything behind the vehicle. Avoid severe driving conditions, such as driving up very steep slopes or running into fixed objects, which can cause the wheels to stop spinning while power is still being supplied to the motors. Make sure your child stops the vehicle before switching speeds or direction.

If a thermal fuse in a battery continually trips under normal driving conditions, please contact your local Power Wheels® Authorized Service Center. For the location of the Authorized Service Center nearest to you, please visit us on-line at www.powerwheels.com or call **1-800-348-0751**.

Important Notes

- Your new battery must be charged for at least 18 hours before you use it in your vehicle for the first time.
- You do not need to remove the battery from your vehicle to recharge it.
- The battery must be upright while charging.
- The charger is not a toy.
- Do not short circuit the battery.
- We recommend that you start charging your battery before beginning assembly of your new vehicle.
- Before charging the battery, examine the battery case for cracks and other damage which may cause sulfuric acid (electrolyte) to leak during the charging process. If damage is detected, do not charge the battery or use it in your vehicle. Battery acid is very corrosive and can cause severe damage to surfaces it contacts.
- Do not charge the battery on a surface which could be damaged by the acid contained inside the battery. Take precautions to protect the surface on which you charge your battery.
- Use only a Power Wheels® 12 volt charger with type “12V” connector (120 VAC 60 Hz 28W with an output of 12 VDC 1200mA) to charge your Power Wheels® rechargeable 12 volt battery.
- If your battery is old and will not accept a charge, do not leave it in the vehicle. Always remove a dead battery from the vehicle.

Battery Charging

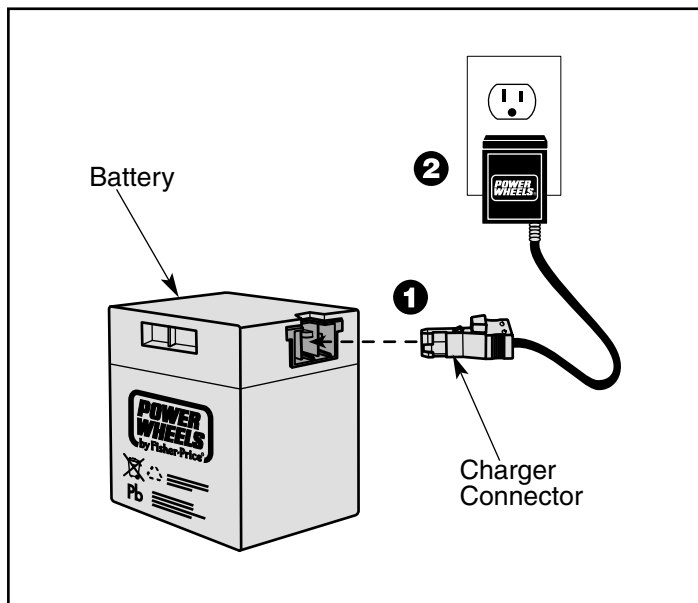

- Plug the charger connector into the battery ❶ .
- Plug the charger into a standard wall outlet ❷ .

Note: If power flow to the wall outlet is controlled by a switch, make sure the switch is "ON".

- Before first-time use, charge the battery for **at least 18 hours**. Never charge the battery longer than 30 hours.
- Recharge the battery for at least 14 hours after each use of your vehicle. Do not charge the battery longer than 30 hours.
- Once the battery is charged, pull firmly on the charger connector to disconnect it from the battery. Unplug the charger from the wall outlet. The battery is now ready to be installed in your vehicle. Please see the Battery Installation section on page 18 for detailed instructions on installing your battery. If your battery is already installed in your vehicle, simply re-connect the motor harness connector to the battery and lower and fasten the hood.

F

Assembly

⚠ WARNING

Children can be harmed by small parts, sharp edges and sharp points in the vehicle's unassembled state, or by electrical items. Care should be taken in unpacking and assembly of the vehicle. Children should not handle parts, including the battery, or help in assembly of the vehicle.

IMPORTANT! The battery clamp unit must be assembled to the dash before assembling the dash to the vehicle body.

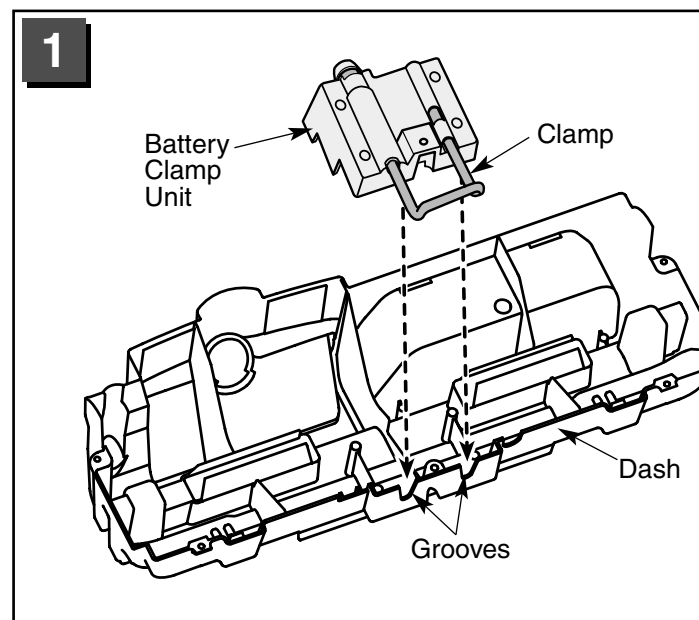

- Position the dash face down.
- Fit the battery clamp unit into the underside of the dash so that the clamp fits into the grooves in the dash. Make sure the battery clamp unit is flush against the surface of the dash.

Assembly

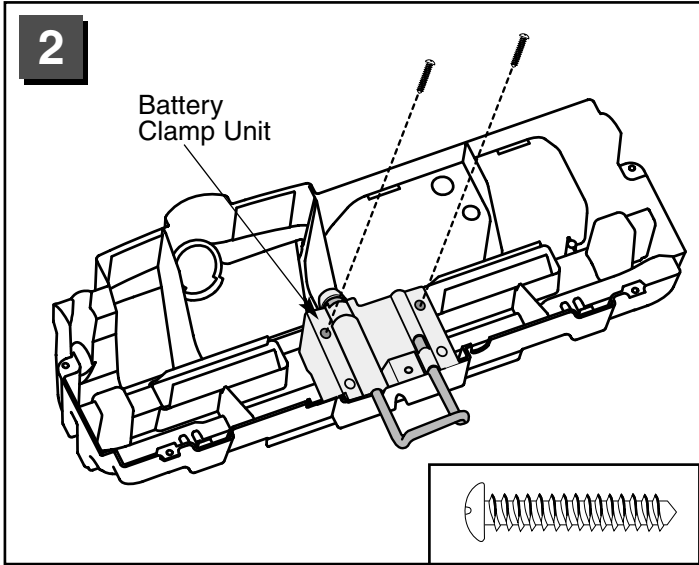

- Insert two #10 x 1" screws through the holes in the battery clamp unit and into the pegs in the dash.
- Tighten the screws with a Phillips screwdriver. Do not over-tighten.

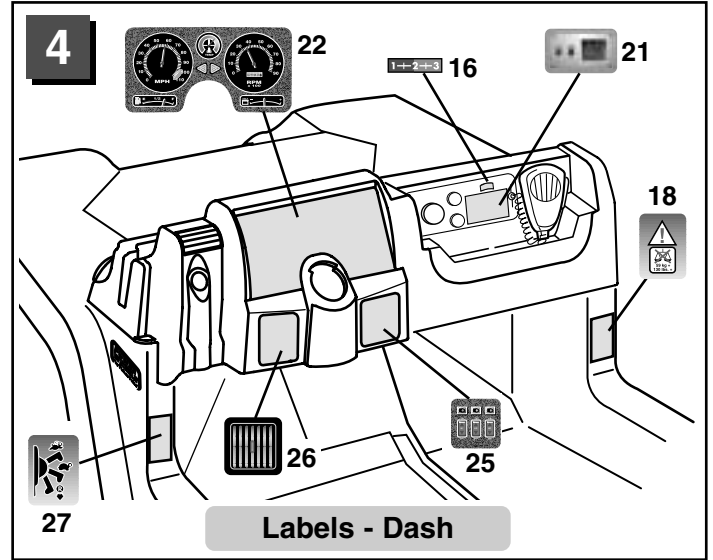

- Before applying the labels, wipe the surface of the vehicle with a clean, dry cloth to remove any dust or oils.
- Place the labels exactly as shown in the illustrations.
- For best results, avoid repositioning a label once it has been applied to the vehicle.

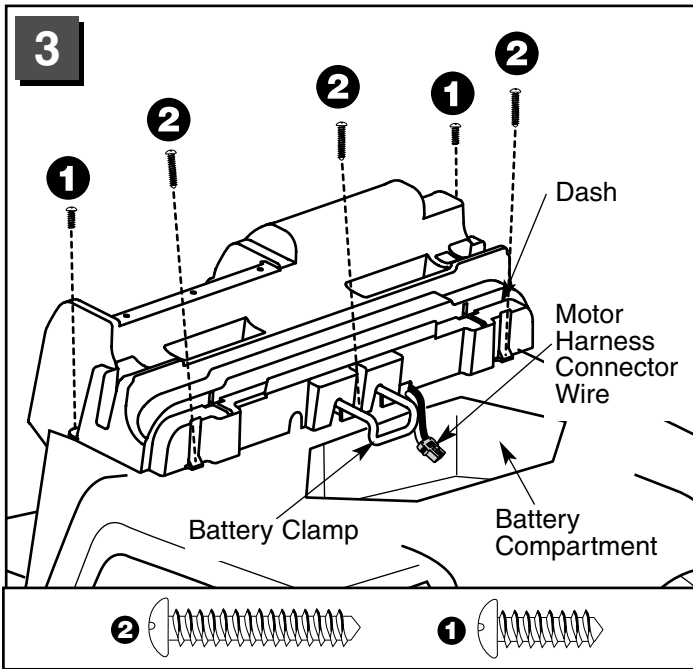

- Position the dash on the vehicle body.
- Make sure the motor harness connector wire is through the groove in the dash.
- Insert a #10 x 1/2" screw through each of the two corner dash tabs nearest to the passenger compartment ①.
- Insert a #10 x 1" screw through the two dash tabs nearest to the battery compartment ②.
- Insert a #10 x 1" screw into the hole in the center of the dash, near the battery retainer clip ②.
- Tighten the screws with a Phillips screwdriver. Do not over-tighten.

Assembly

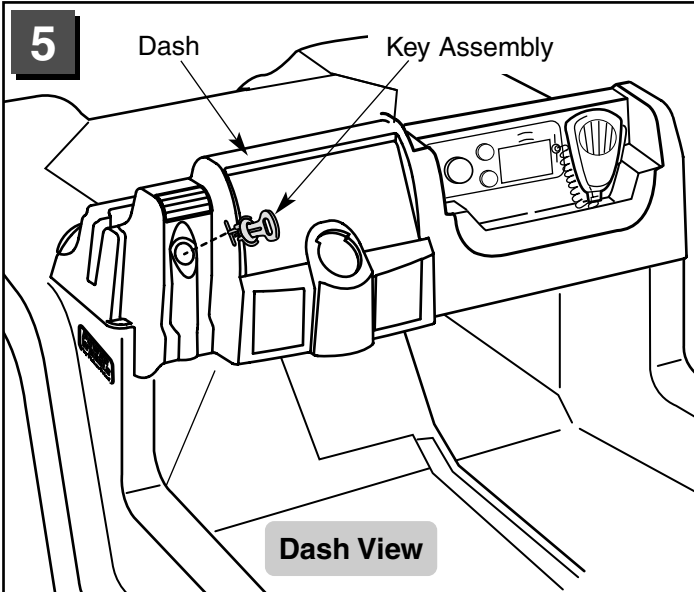

- Insert and “snap” the key assembly into the opening in the dash, as shown.

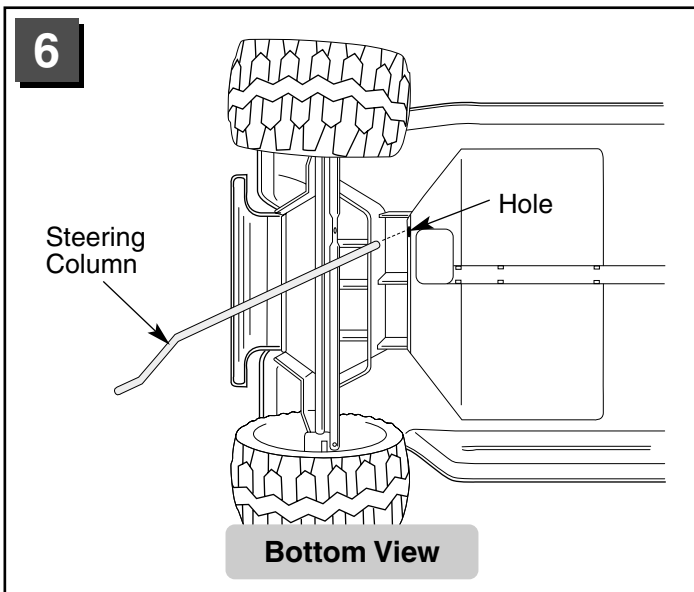

- Wipe the steering column with a paper towel to remove any excess lubricant.
- Turn the vehicle on its side.
- Insert the straight end of the steering column up through the hole in the vehicle body wall and out through the hole in the dash.

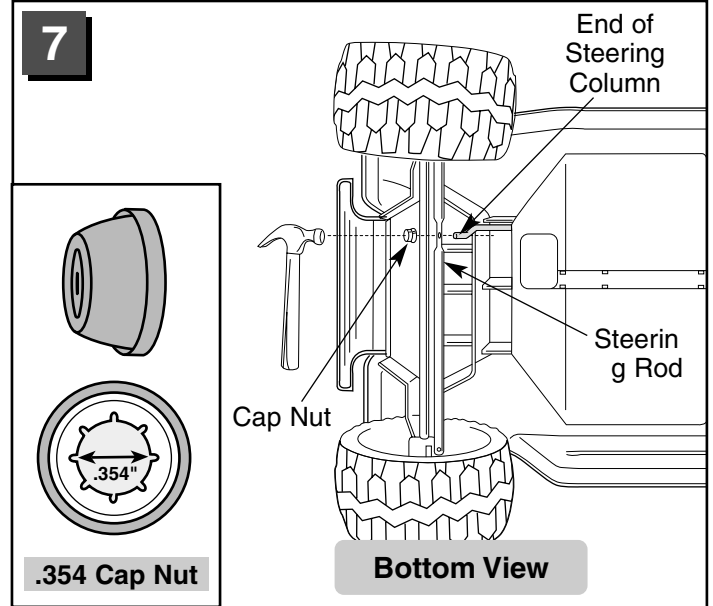

- Insert the end of the steering column through the hole in the steering rod.
- Fit a cap nut onto the end of the steering column.
- While supporting the steering column, tap the cap nut with a hammer to secure it on the steering column.

Hint: You may want the help of another person to support the steering column while you tap the cap nut with the hammer.

Assembly

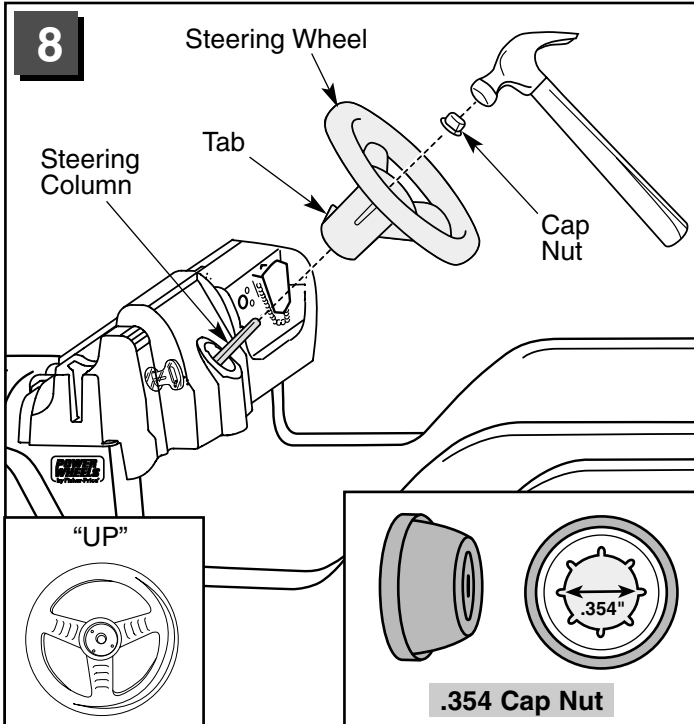

- Turn the vehicle upright.
- Position the steering wheel so that the spokes form a "Y" as shown. The tab on the steering wheel stem should face up.
- Fit the steering wheel onto the steering column.
- Fit a cap nut onto the end of the steering column.
- Tap the cap nut with a hammer to secure it on the steering column.

Hint: You may want the help of another person to support the steering column while you tap the cap nut with the hammer.

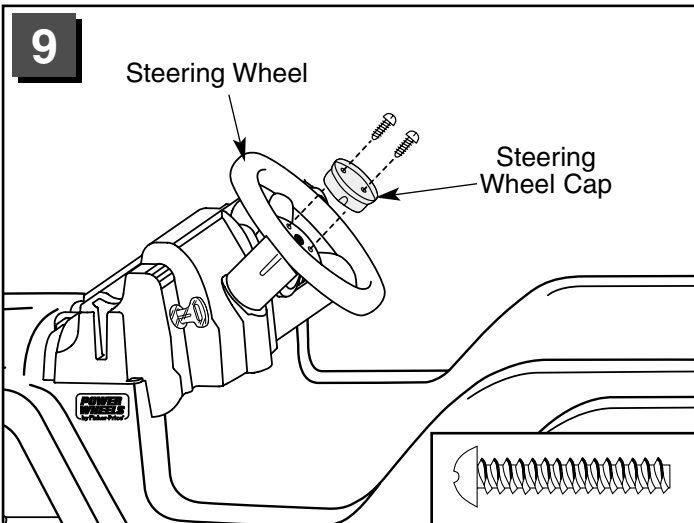

- Fit the steering wheel cap into the center of the steering wheel.
- Insert two #8 x 1" screws, as shown.
- Tighten the screws with a Phillips screwdriver. Do not over-tighten.

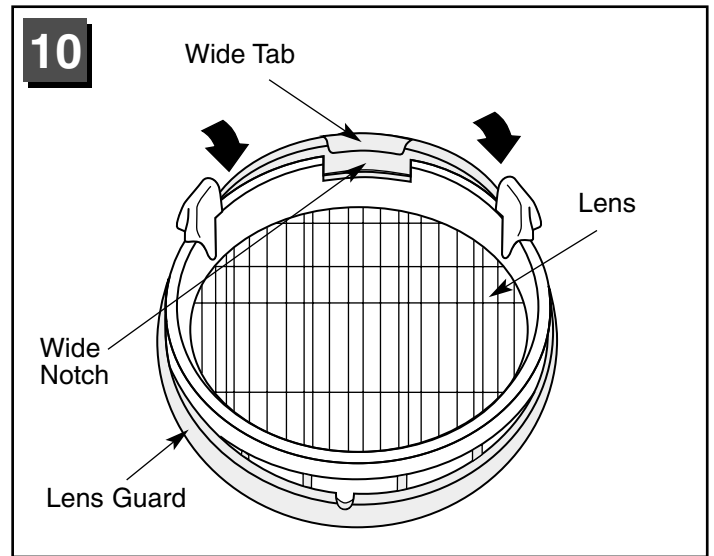

- Fit the wide notch in the side of a headlight lens under the wide tab on a lens guard.
- Press firmly on the inside of the headlight lens to snap it into the lens guard.
- Repeat this procedure to assemble the other headlight lens to the remaining lens guard.

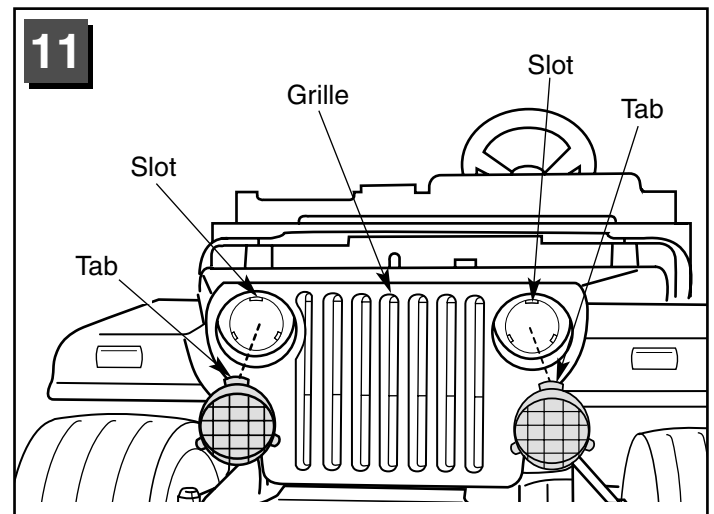

- Fit the lens tabs on the back of a lens assembly into the headlight slots in the grille.
- Press firmly to snap the lens assembly into the grille.
- Repeat this procedure to snap the other lens assembly into the grille.

Assembly

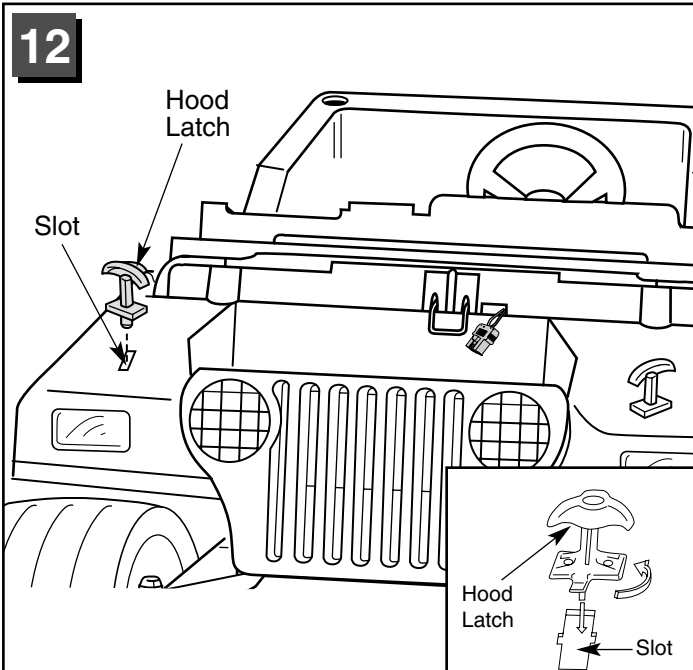

- Insert a hood latch into one of the slots in the vehicle body, near the hood area.
- Twist the base of the hood latch $\frac{1}{4}$ turn to secure it in the vehicle body.
- Repeat this procedure on the other side of the hood area to attach the other hood latch to the vehicle body.

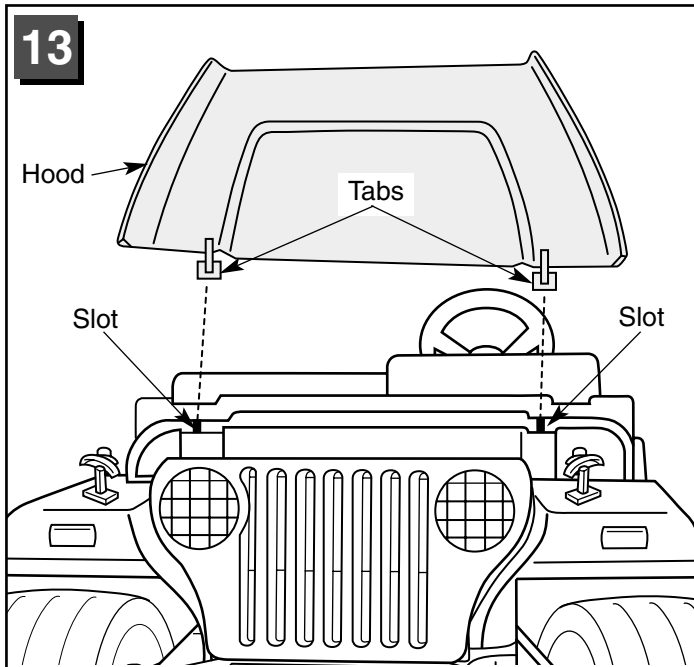

- Position the hood over the front of the vehicle body as shown.
- Insert the tabs on the hood into the slots in the vehicle body.
- Close the hood.

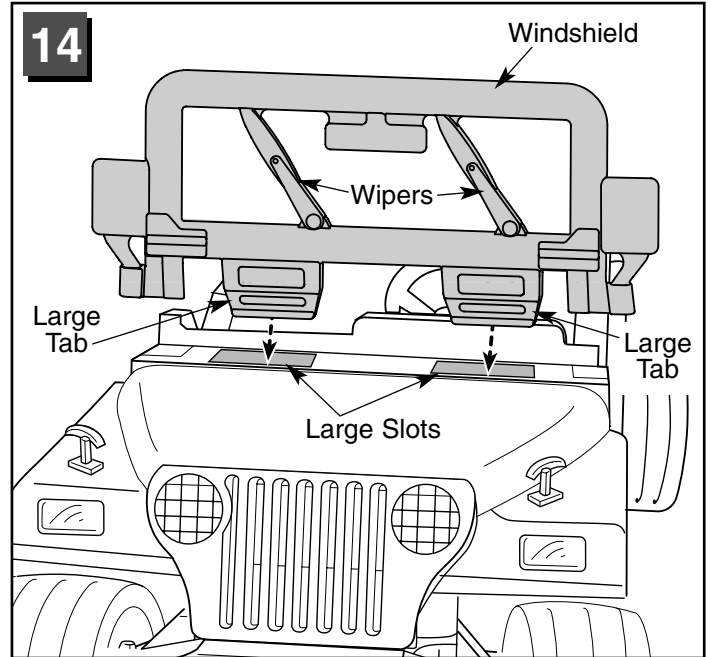

- Position the windshield so that the **wipers face the front** end of the vehicle.
- Insert and **"snap"** the two large tabs on the windshield into the large slots in the dash.
- Pull up on the windshield to be sure it is secure.

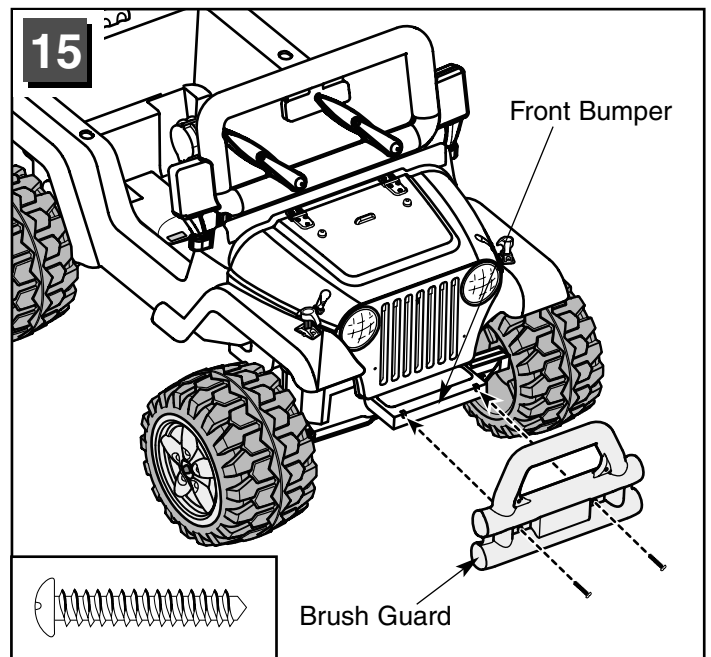

- Fit and hold the brush guard against the front bumper.
- Insert two #10 x 1" screws through the front of the brush guard and into the front bumper.
- Tighten the screws with a Phillips screwdriver. Do not over-tighten.

Assembly

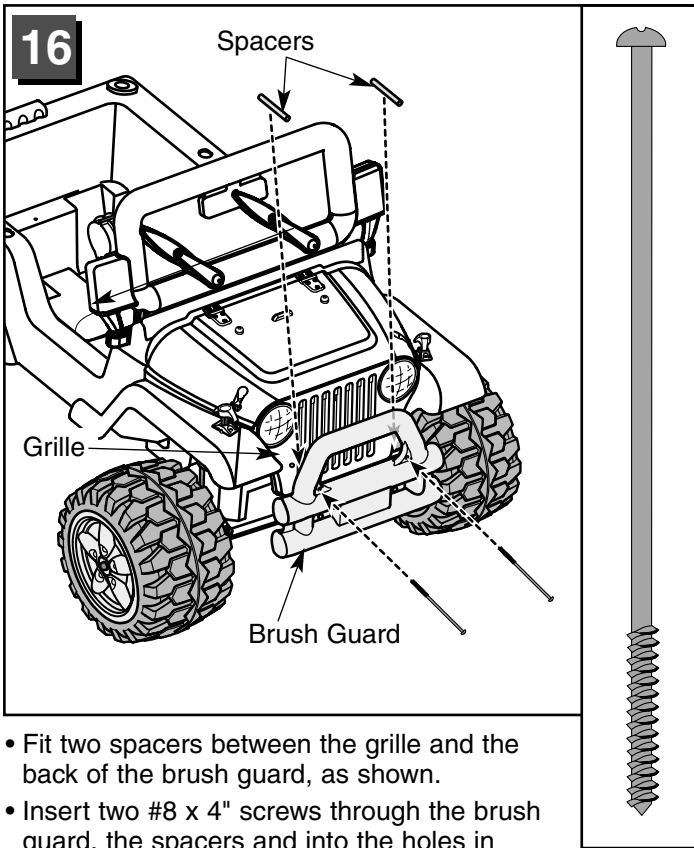

- Fit two spacers between the grille and the back of the brush guard, as shown.
- Insert two #8 x 4" screws through the brush guard, the spacers and into the holes in the grille.
- Tighten the screws with a Phillips screwdriver. Do not over-tighten.

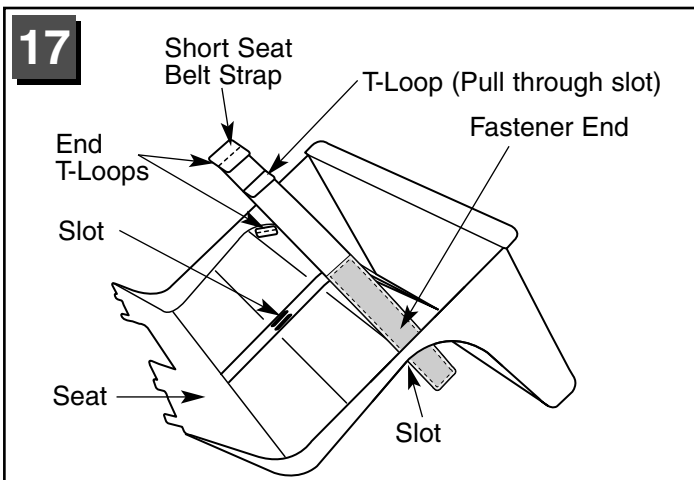

- Turn the seat upside down.
- Insert the fastener end of a short seat belt strap through the slot near the outer edge of the seat. Make sure the side of the seat belt with the fastener faces the outer edge of the seat.
- Pull the short seat belt strap completely through the slot until the last T-loop at the opposite end of the belt catches against the slot. You will pull one T-loop through the slot.
- Repeat this procedure to assemble the other short seat belt strap.

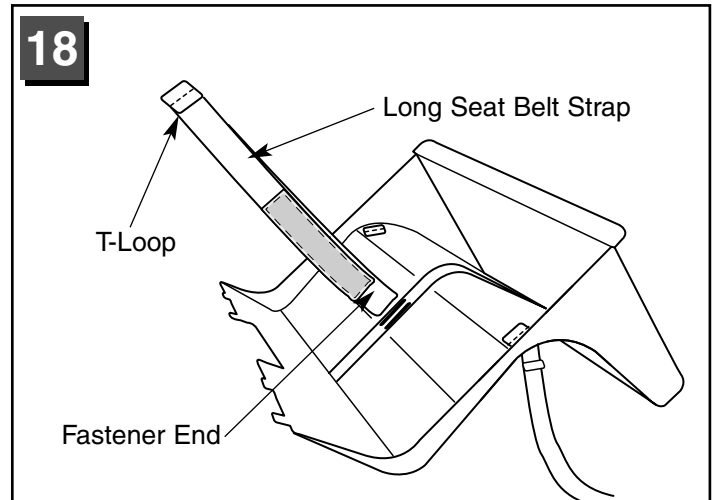

- Insert each fastener end of the long seat belt strap through a slot in the center of the seat. Make sure the fasteners face the outer edge of the seat.
- Pull each side of the long seat belt strap evenly through the slots. Make sure to pull each T-loop through a slot.
- Turn the seat upright.

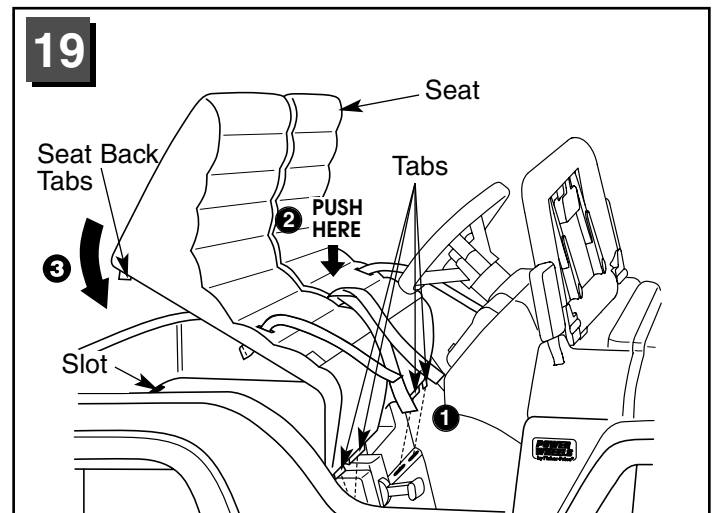

- With the seat at an angle, insert the tabs on the front edge of the seat into the slots in the foot-well wall ①.
- Push down firmly on the edge of the seat above each tab to snap the tabs into the slots ②.
- Rotate the back of the seat down ③ to snap the seat back tabs into the slots in the vehicle body. Push down firmly on the seat back.

Assembly

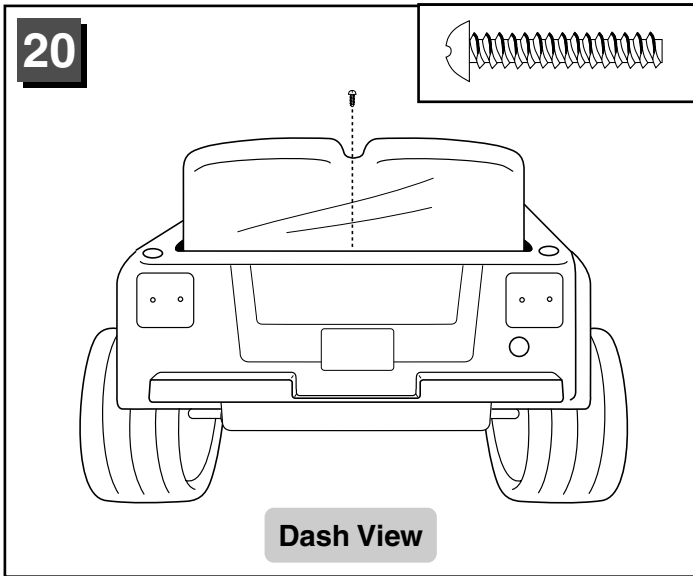

- Insert a #8 x 1" screw into the rear of seat, as shown.
- Tighten the screw with a Phillips screwdriver. Do not over-tighten.

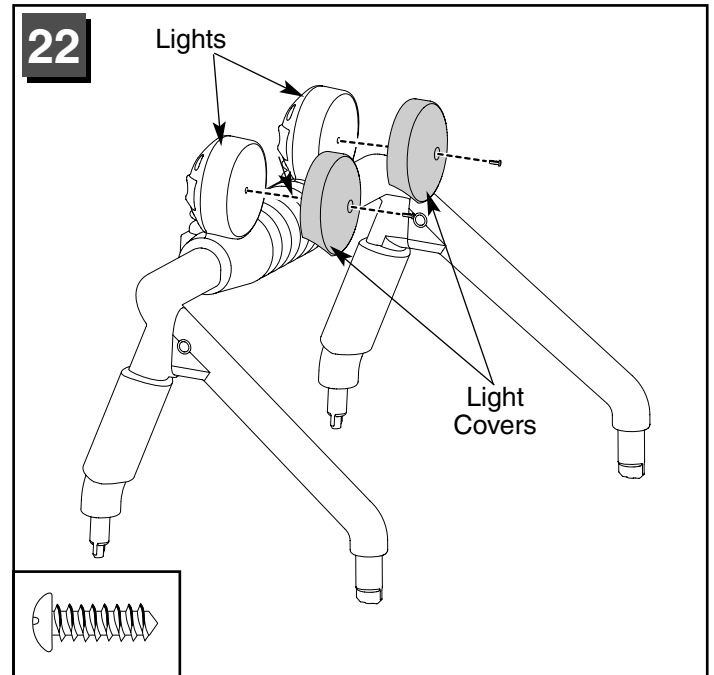

- Fit the light covers to the lights on the sport bar, as shown.
- Insert a #10 x 1/2" screw through the light cover and into the light. Tighten the screws with a Phillips screwdriver. Do not over-tighten.

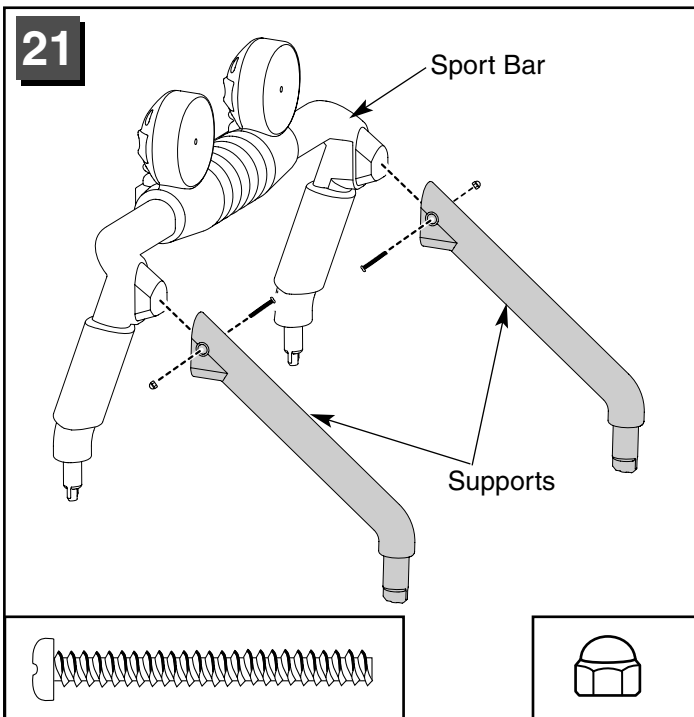

- Fit a support to one side of the sport bar.
- Insert a #8-32 x 1.625" screw through the support, the sport bar and out through the support.
- Fit a lock nut to the end of the screw.
- While holding the lock nut with the pliers, tighten the screw with a Phillips screwdriver. Do not over-tighten.

Assembly

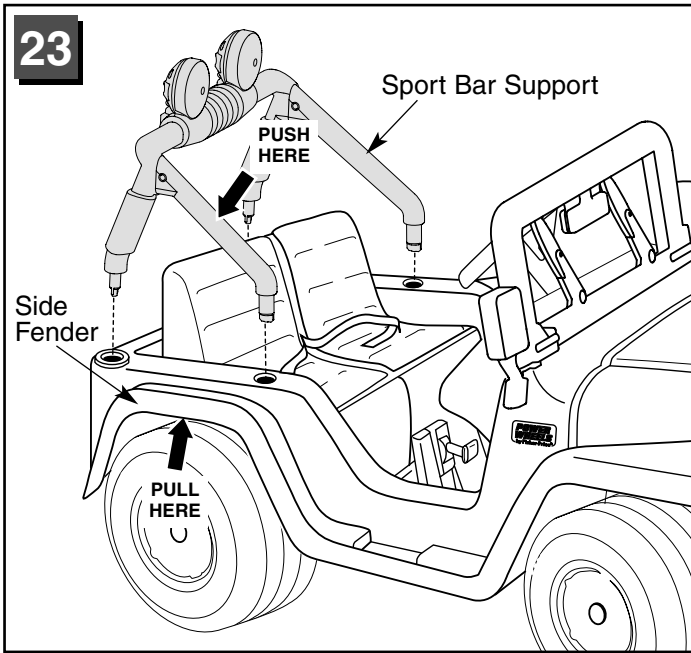

- Fit the sport bar into the holes in the vehicle body.
- Push down firmly on a sport bar support while pulling up on the side fender to fit the sport bar into the vehicle body.
- Repeat this procedure on the other side of the vehicle body.

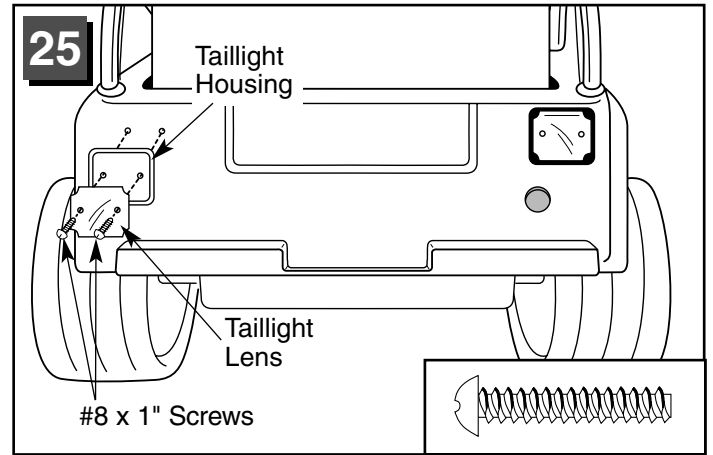

- Turn the vehicle upright.
- Using safety scissors, remove the taillight lenses and the taillight housings from the plastic connectors. Dispose of the plastic connectors.
- Face the rear of the vehicle.
- Fit a taillight lens inside a taillight housing.
- Position the taillight housing with lens against the vehicle body with the screw holes aligned, as shown.
- Insert two #8 x 1" screws through the taillight lens and housing and into the vehicle body as shown.
- Tighten the screws with a Phillips screwdriver. Do not over-tighten.
- Repeat this procedure to attach the other taillight.

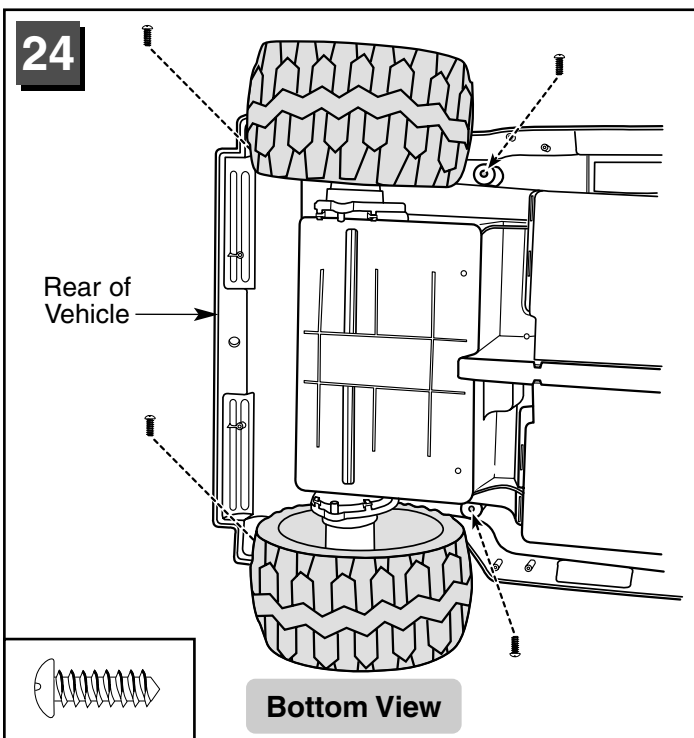

- Turn the vehicle on its side.
- Insert two #10 x 1/2" screws into the holes in the underside of each rear wheel well, through the vehicle body and into the ends of the sport bar.
- Tighten the screws with a Phillips screwdriver. Do not over-tighten.

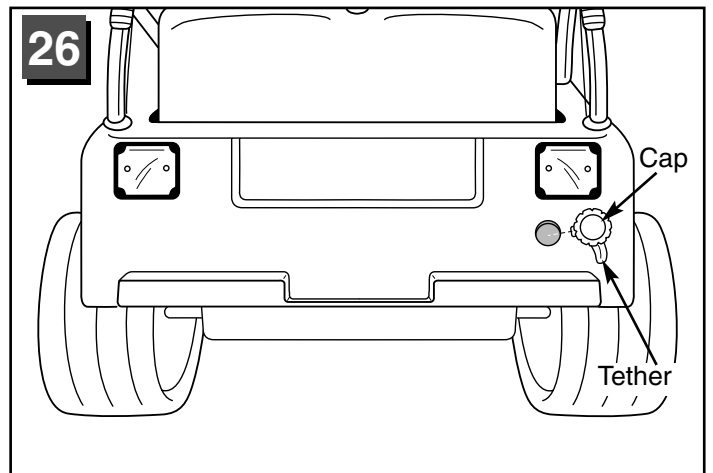

- Position the cap so that its tether points down.
- Snap the cap into the hole under the right taillight.

G

Label Decoration

Proper label application will help to keep the labels looking their best! When applying labels, keep the following guidelines in mind:

- Wash your hands before applying the labels.
- Before applying the labels, wipe the surface of the vehicle with a clean, dry cloth to remove any dust or oils.
- Place the labels exactly as shown in the illustrations.
- For best results, avoid repositioning a label once it has been applied to the vehicle.
- After applying a label, rub the label firmly with a clean, dry cloth to make sure the label is adhered to your vehicle. Start at the center of a label, and smooth towards the outer edges to remove air bubbles.

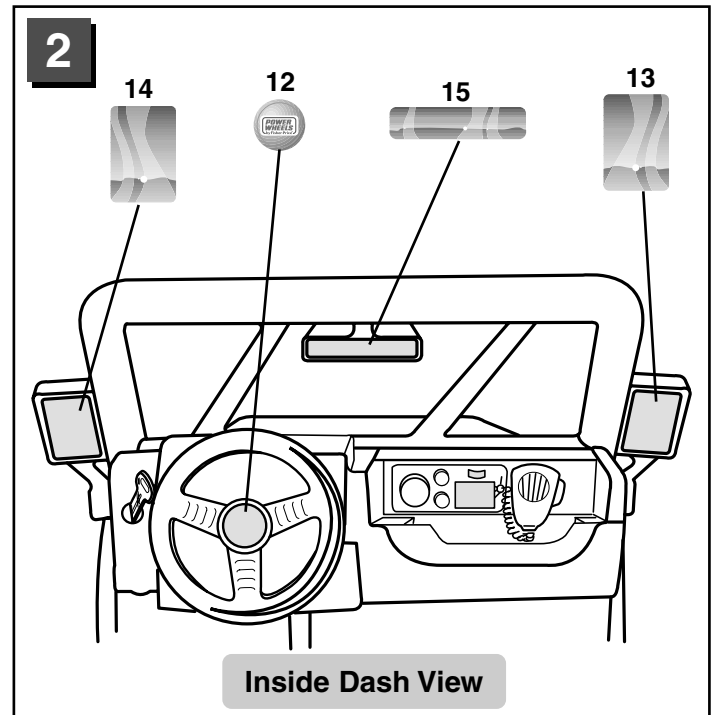
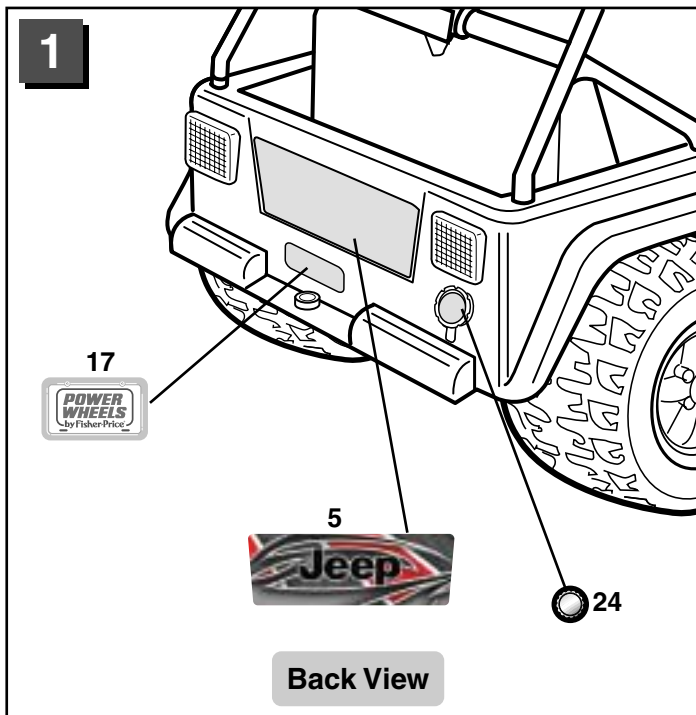

Label Decoration

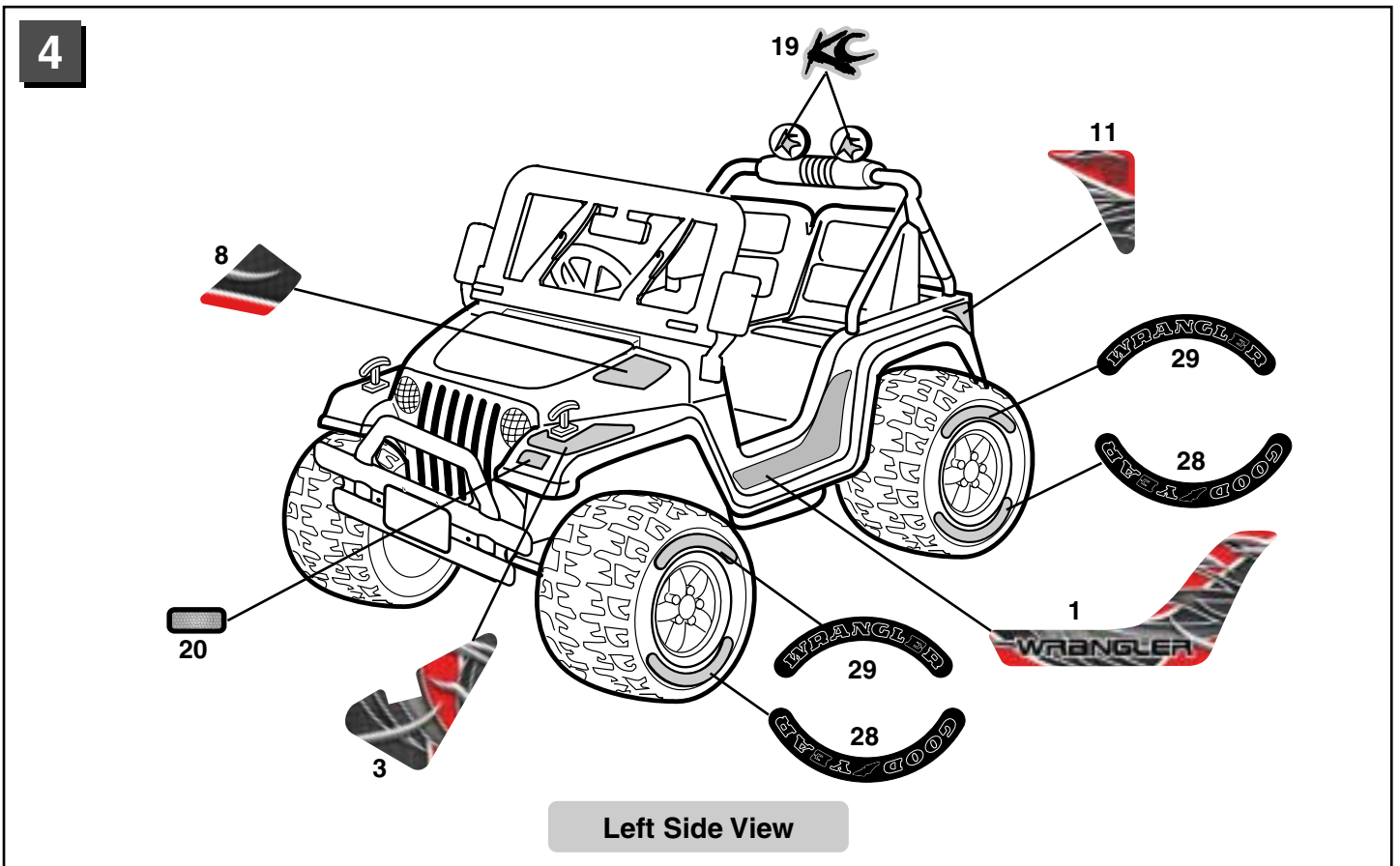
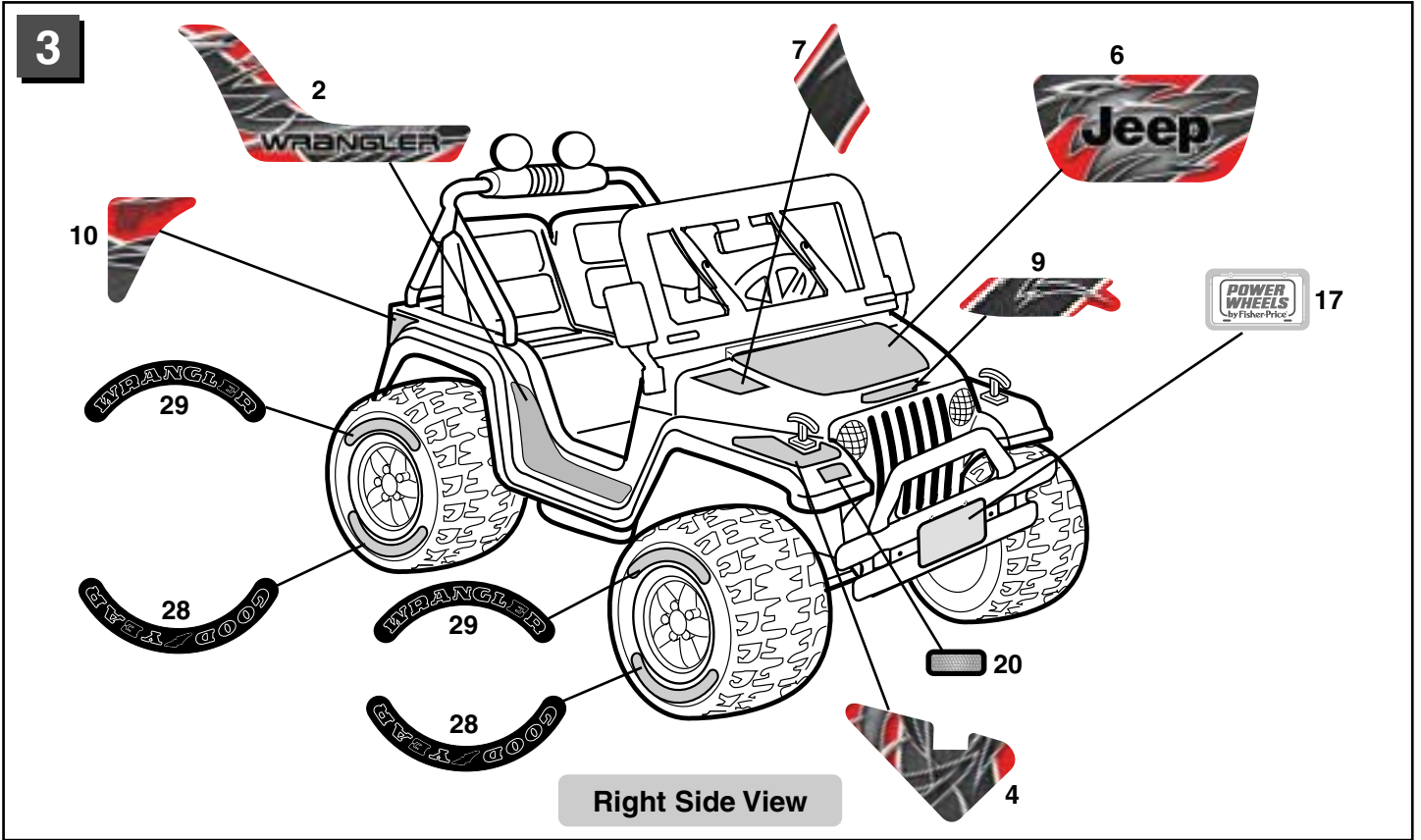

H

Battery Installation

IMPORTANT! Use only a Power Wheels® 12 volt battery. Use of any other battery will damage your vehicle. Make sure that you charge the battery for at least 18 hours using the enclosed Power Wheels® 12 volt charger before operating your vehicle for the first time. Charge the battery for at least 14 hours after each use of the vehicle. Never charge the battery longer than 30 hours. Failure to follow these instructions may damage your battery and will void your warranty. It is easier to install the battery before assembling the hood to your vehicle. If you have already assembled the hood to your vehicle, you may want to remove it to install the battery.

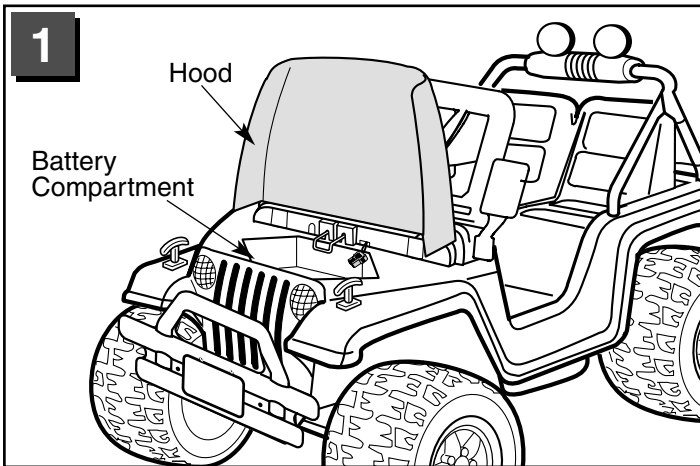

- Lift the hood to access the battery compartment.

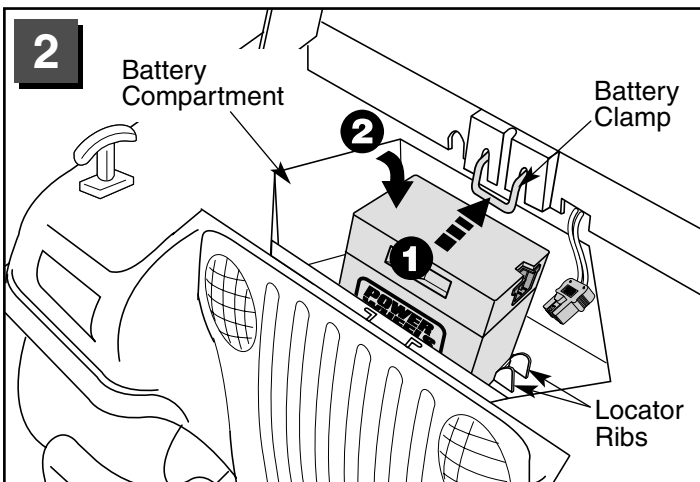

- Press the battery clamp to slide it into the dash ①.
- While holding the battery clamp against the dash, place the battery in the battery compartment ②. Make sure the battery is upright and positioned between the locator ribs at the bottom of the battery compartment.

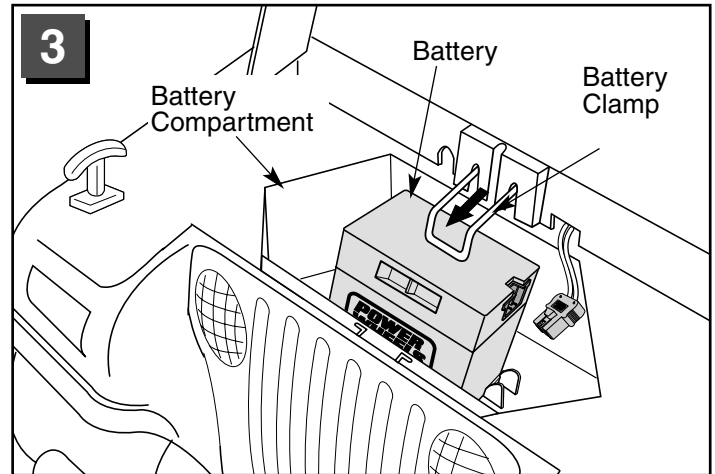

- Release the battery clamp. Make sure the battery clamp slides over the top of the battery. If the battery clamp does not slide over the top of the battery, reposition the battery in the battery compartment. (See step 2.)

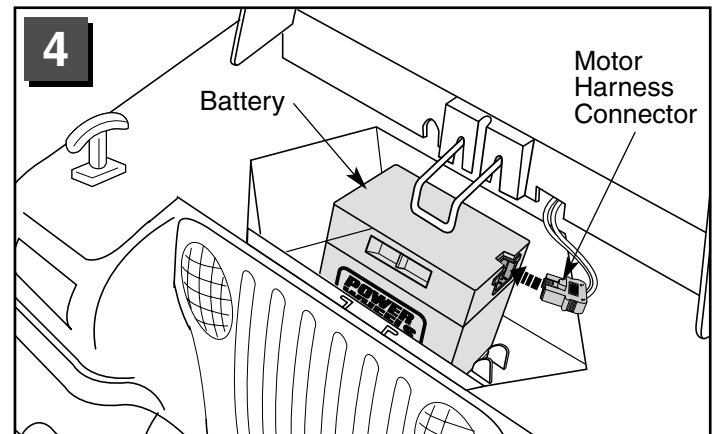

- Plug the motor harness connector into the battery. **Push firmly to make sure the connectors are completely joined.**

Hint: To remove a battery from the battery compartment, disconnect the motor harness connector from the battery. Press and hold the battery clamp against the dash and lift the battery from the battery compartment.

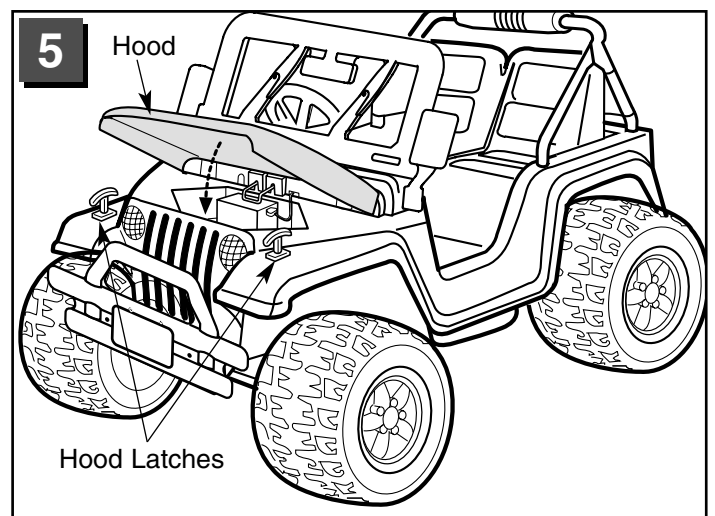

- Lower the hood and secure the hood latches.

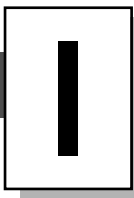

Battery Care and Disposal

Care

If a battery leak develops, avoid contact with the leaking acid and place the damaged battery in a plastic bag. Please refer to the information on this page for proper disposal.

If acid comes in contact with skin or eyes, flush with cool water for at least 15 minutes and call a physician.

If acid is internally ingested, give water, milk of magnesia or egg whites immediately. Never give emetics or induce vomiting. Call a physician.

- Charge a new battery for at least 18 hours before first use. Never charge the battery longer than 30 hours. Overcharging or undercharging the battery may shorten battery life and decrease vehicle running time.
- After the first charge, recharge the battery for at least 14 hours after each use. Never charge the battery longer than 30 hours. Charge the battery after each use, regardless of how long the vehicle was used.
- The battery must be upright while charging.
- Do not allow the battery to run down completely before charging.
- Charge the battery before storing the vehicle.
- Charge the battery at least once per month, even if the vehicle has not been used.
- Leaving the battery in a discharged condition will ruin it.
- Do not store the battery in temperatures above 75° F or below -10° F.
- Use only a Power Wheels® 12 volt battery. Remember to charge the new battery at least 18 hours before first time use.
- Prevent the battery from moving freely inside the battery compartment. Always use the battery clamp to secure the battery in the battery compartment.
- Examine the battery, charger and its connector for excessive wear or damage each time you charge the battery. If damage is detected, do not use the charger or the battery until you have replaced the worn or damaged part.
- Always remove an exhausted battery from the vehicle. Battery leakage and corrosion can damage the vehicle.

Disposal



- Your Power Wheels® battery is a sealed lead-acid battery. It must be recycled or disposed of in an environmentally sound manner.
- Do not dispose of a lead-acid battery in your regular, household trash. The incineration, landfilling or mixing of sealed lead-acid batteries with household trash is prohibited by law in most areas.
- Do not dispose of a lead-acid battery in a fire. The battery may explode or leak.
- Return exhausted batteries to a federal or state approved lead-acid battery recycler, such as a Power Wheels® authorized service center, or a local seller of automotive batteries. For the service center location nearest you, please call 1-800-348-0751. Contact your local waste management officials for other information regarding the environmentally sound collection, recycling and disposal of lead-acid batteries. If you live in the State of Florida or Minnesota, it is prohibited by law for anyone to throw away lead-acid batteries in the municipal waste stream.

RIDING HAZARD**WARNING****Prevent Injuries and Deaths**

- Direct Adult Supervision Required.
- Keep Children Within Safe Riding Areas

These areas must be:

- away from swimming pools and other bodies of water to prevent drownings.
- generally level to prevent tipovers.
- away from steps, driveways, cars, roads and alleys.

Teach Safety Rules to Children

While children can quickly develop the skill necessary to drive this vehicle, it is important to remember that their judgment skills are still very immature. Unsupervised driving by children can lead to serious injury. Before children use this vehicle, an adult should carefully evaluate the driving area as well as the children's skill level and ability to drive this vehicle safely. Children are not always able to recognize or anticipate hazards, even when they have been taught about them. **THERE IS NO ACCEPTABLE SUBSTITUTE FOR DIRECT ADULT SUPERVISION.**

Teach appropriate safety rules to your child before allowing operation of this vehicle. These rules should also be reviewed with neighborhood children or other playmates who want to drive this vehicle.

Riding Rules

Make sure children know and follow these rules for safe driving:

1. Always sit on the seat.
2. Always wear shoes.
3. Only 2 (two) riders at a time. A child who is not sitting on the seat or who is standing on the vehicle could fall off, cause a tip-over or block the driver's view. A child could be seriously injured.
4. Do not allow any child to drive the vehicle in the street or near moving (motorized) vehicles.
5. Do not allow any child to drive near bodies of water (such as pools or creeks), obstructions (such as furniture, low tree limbs or play equipment), or drop-offs (such as stairs or decks).
6. Do not allow any child to drive the vehicle in the dark. A child could encounter unexpected obstacles and have an accident. Operate the vehicle only in the daytime or a well-lit area.



Use vehicle on generally level ground ONLY!

7. Do not allow your child to drive on sloped or inclined surfaces. Restrict your child's driving to generally level ground ONLY!
8. Do not allow your child to drive down or across a steep slope.
 - The vehicle may gain unsafe speed, even if the pedal is released to stop.
 - The vehicle may tilt and tip over.
 - The wheels could lose traction, causing the vehicle to slip.
9. Do not allow your child to drive up steep inclines. The motor may stop and the vehicle could roll backwards at an unsafe speed.
10. Never put anything near any moving parts. Rotating parts such as motors, gear boxes and wheels can snag fingers, hair, etc., causing serious injury. Do not allow operation of the vehicle when it is on its side or in an upside-down position.
11. Do not operate the vehicle near flammable vapors (gasoline, paint thinner, acetone, liquid wax, etc.). The vehicle's electrical switches, like most electrical switches, emit an internal spark when first turned on or turned off. The presence of flammable liquids or vapors could cause an explosion or a fire. Keep all flammable products in tightly sealed containers and away from the vehicle.
12. Do not allow a child to operate the vehicle without direct adult supervision. To prevent unsupervised use of the vehicle, disconnect the motor harness from the battery when the vehicle is not in use.

To disconnect the motor harness connector and battery:

- Unfasten the hood latches and raise the hood.
- Unplug the motor harness connector from the battery.
- Lower the hood and fasten the hood latches.

K

How to Operate Your Vehicle

Beginner Use - Low Speed Drive

As assembled, your vehicle is ready to roll in low speed (2½ mph, maximum). It has been pre-set so it will only operate in low speed. After your child has mastered the basic skills of driving and understands the rules for safe driving, it's time to remove the high speed lock-out screw to allow the vehicle to operate in low or high speed. **See the instructions on page 22 to remove the high speed lock-out screw.**

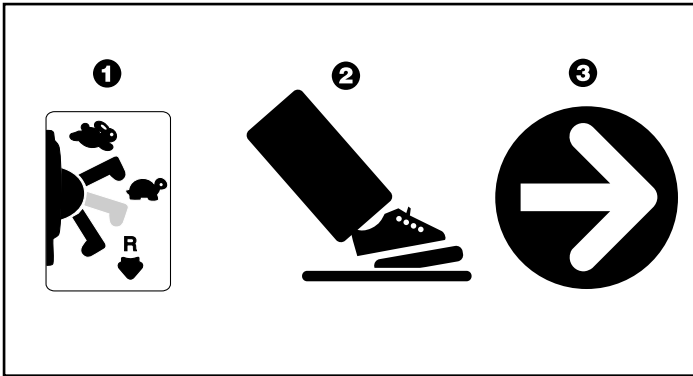

- Make sure the shifter is in the low speed  position ①.
- Press down on the foot pedal ②. The vehicle goes forward at a maximum of 2½ mph ③.
- Help your child practice steering to learn how far and how quickly to turn the steering wheel when driving forward in low speed.

To Stop

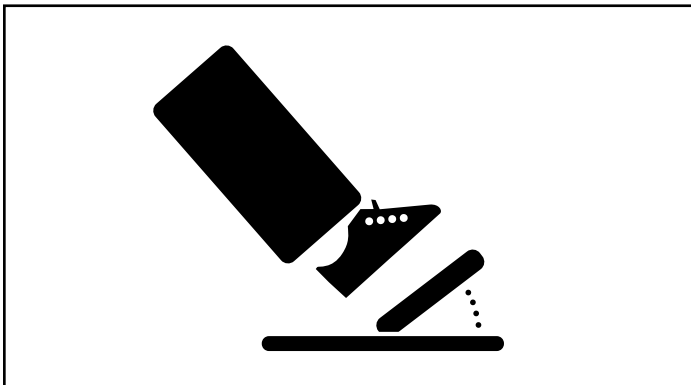

- Your vehicle has a patented electronic braking system that automatically stops the vehicle when your child's foot is lifted from the pedal.
- Make sure your child is comfortable with steering the vehicle and automatically knows how to stop.

To Back Up

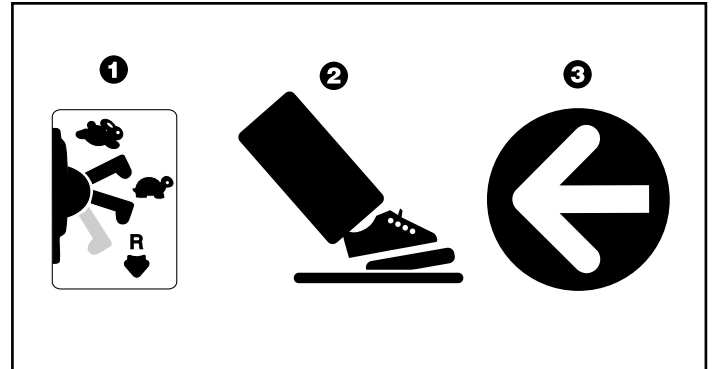

Note: To avoid damaging the motors and gears, stop the vehicle before shifting from forward to reverse .

- Once your child is completely comfortable with operating the vehicle in the forward mode, introduce reverse .

To Back Up

- Make sure the shifter is in the reverse  position ①.
- Press down on the foot pedal ②. The vehicle will go in reverse at a maximum of 2½ mph ③. The vehicle is designed to operate in low speed only in reverse.
- Help your child practice steering to learn how far and how quickly to turn the steering wheel when driving in reverse.

How to Operate Your Vehicle

Advanced Use - High Speed Drive

Disconnecting the High Speed Lock-Out

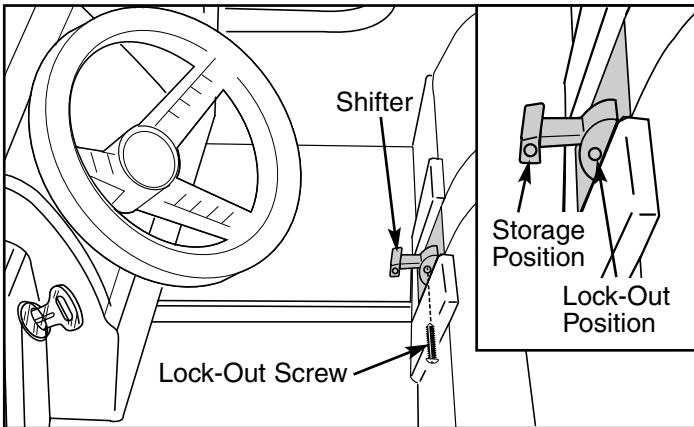

- Before you disconnect the high speed lock-out, make sure your child knows how to steer, how to start and stop the vehicle and knows the rules for safe driving. When the high speed lock-out is disconnected, the vehicle can be driven forward in low speed (2½ mph, maximum) or high speed (5 mph, maximum).
- Make sure the shifter is in the reverse  position.
- Loosen the screw in the shifter box using a Phillips screwdriver.
- Remove the screw.
- Insert the lock-out screw into the hole in the shifter handle to keep it for future use. It can be re-inserted into the shifter box to lock-out high speed.

To Drive

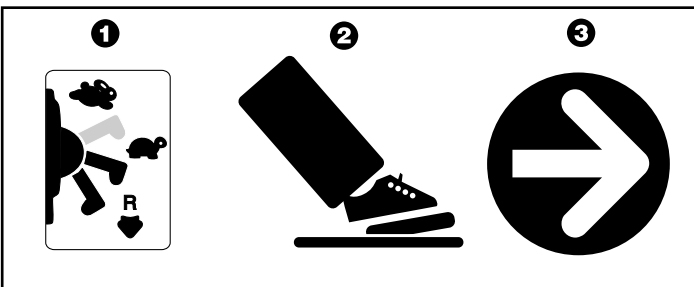

IMPORANT! To avoid damaging the motors and gears, stop the vehicle before shifting between low and high speed.

- Make sure the shifter is in the high speed  position ①.
- Press down on the foot pedal ②. The vehicle goes forward at a maximum of 5 mph ③.
- Help your child practice steering to learn how far and how quickly to turn the steering wheel when driving forward in high speed.
- Make sure your child is comfortable with steering the vehicle and automatically knows how to stop.
- Stopping in high speed is the same as stopping in low speed. The vehicle automatically stops when your child's foot is lifted from the pedal.



Caring For Your Vehicle

- Check all screws, cap nuts and protective coverings regularly and tighten as required. Check plastic parts on a regular basis for cracks or broken pieces.
- During snowy or rainy weather, the vehicle should be stored inside or under a protective cover. Remember to charge the battery at least once per month while your vehicle is not in regular use.
- Avoid operating the vehicle in wet or snowy conditions and do not spray the vehicle with a hose. Do not wash the vehicle with soap and water. Water or moisture in the motors or electrical switches can cause them to corrode and could cause switch or motor failure.
- Avoid operating the vehicle on sand, loose dirt or gravel. Sand, loose dirt or gravel in the motors or electrical switches can cause them to jam and could cause switch or motor failure.
- The vehicle can be wiped down with a soft, dry cloth. For a shiny finish, you can wipe plastic parts with a non-wax furniture polish applied to a soft-cloth. Do not use automotive wax. Do not use soap and water or spray the vehicle with a hose.
- To ensure that your vehicle stays in good operating order, we recommend that you periodically have your vehicle checked by a Power Wheels® authorized service center. For the location of the authorized service center nearest to you, visit us on-line at www.powerwheels.com.

M

Problems and Solutions Guide

IMPORTANT! If you experience a problem with your vehicle, first check the Problems and Solutions Guide below. If you still experience a problem, please contact Power Wheels® Consumer Relations, toll-free at **1-800-348-0751** between 8 AM and 6 PM (EST) Monday through Friday. Or, contact your local Power Wheels® authorized service center. For the location nearest you, please visit us on-line at www.powerwheels.com.

Problem	Possible Cause	Solution
Vehicle does not run	Undercharged battery	Charge the battery. A new battery should have been charged for at least 18 hours before using the vehicle for the first time. After first-time use, recharge the battery for at least 14 hours after each use. Never charge the battery longer than 30 hours.
		Check all connectors. Make sure the charger connector is plugged into the battery, and that the charger is plugged into the wall.
		Make sure power flow to the wall outlet is "ON".
	Charger is not working	There is no sure way to tell if your charger is working unless you have a volt meter. If you suspect there is a problem with your charger, contact your local Power Wheels® authorized service center. They can test your charger for you.
	Tripped thermal fuse	Each Power Wheels® 12 volt battery has a built-in thermal fuse. A thermal fuse may "trip" and shut down operation of the vehicle if the vehicle is overloaded or the driving conditions too severe. The fuse will automatically reset itself after approximately 25 seconds, allowing the vehicle to resume normal operation. To avoid repeated automatic shutdowns, do not overload the vehicle by exceeding the 130 lb. maximum weight capacity or by towing anything behind the vehicle. Do not drive up hills or run into fixed objects, which can cause the wheels to stop spinning while power is still being supplied to the motors. If a thermal fuse continually trips, contact your local Power Wheels® authorized service center.
	Loose wire or loose connectors	Check all wires and connectors. Make sure the motor harness connector is plugged into the battery, and that there are no loose wires around the motors.
	Dead battery	If your battery is old or if you have not followed Battery Care instructions, your battery may be dead. If you are unsure whether or not the battery is dead, you can have it tested at your local Power Wheels® authorized service center.
	Electrical switch damage	The electrical switches can become corroded due to exposure to water or moisture, or can jam due to loose dirt, sand or gravel. Contact your local Power Wheels® authorized service center for diagnosis and repair.
Vehicle was running but suddenly stopped	Motor damage	Contact your local Power Wheels® authorized service center for diagnosis and repair.
	Loose wire or loose connectors	Check all wires and connectors. Make sure the motor harness connector is plugged into the battery, and that there are no loose wires around the motors.
	Tripped thermal fuse	Each Power Wheels® 12 volt battery has a built-in thermal fuse. A thermal fuse may "trip" and shut down operation of the vehicle if the vehicle is overloaded or the driving conditions too severe. The fuse will automatically reset itself after approximately 25 seconds, allowing the vehicle to resume normal operation. To avoid repeated automatic shutdowns, do not overload the vehicle by exceeding the 130 lb. maximum weight capacity or by towing anything behind the vehicle. Do not drive up hills or run into fixed objects, which can cause the wheels to stop spinning while power is still being supplied to the motors. If a thermal fuse continually trips, contact your local Power Wheels® authorized service center.

Problems and Solutions Guide

Problem	Possible Cause	Solution
Short run time (Less than 1 - 3 hours per charge)	Undercharged battery	Charge the battery. A new battery should have been charged for at least 18 hours before using the vehicle for the first time. After first-time use, recharge the battery for at least 14 hours after each use. Never charge the battery longer than 30 hours.
		Check all wires and connectors. Make sure the charger connector is plugged into the battery, and that the charger is plugged into the wall.
		Make sure power flow to the wall outlet is "ON".
	Overcharged battery	Do not charge the battery longer than 30 hours. If you suspect that your battery is damaged as a result of overcharging, contact your local Power Wheels® authorized service center. They can test your battery for you.
	Battery is old and will not accept full charge	Even with proper care, a rechargeable battery does not last forever. Average battery life is 1 to 3 years depending on vehicle use and use conditions. Replace the battery with a new Power Wheels® 12 volt rechargeable battery. Do not substitute parts.
Vehicle runs sluggishly	Undercharged battery	Charge the battery. A new battery should have been charged for at least 18 hours before using the vehicle for the first time. After first-time use, recharge the battery for at least 14 hours after each use. Never charge the battery longer than 30 hours.
		Check all connectors. Make sure the charger connector is plugged into the battery, and that the charger is plugged into the wall.
		Make sure power flow to the wall outlet is "ON".
	Battery needs charging	Be sure to charge the battery after each use.
	Battery is old and will not accept full charge	Even with proper care, a rechargeable battery does not last forever. Average battery life is 1 to 3 years depending on the vehicle use and use conditions. Replace the battery with a new Power Wheels® 12 volt rechargeable battery. Do not substitute parts.
Vehicle is overloaded	Make sure you do not overload the vehicle by allowing more than 2 riders at one time, by exceeding the 130 lb. maximum weight capacity, or by towing objects behind the vehicle.	
Driving conditions are too stressful	Use only on generally level ground.	

Problems and Solutions Guide

Problem	Possible Cause	Solution
<p>Vehicle runs in low speed, but does not run in high speed</p> <p>Please Note: The vehicle is designed to operate in low speed only in reverse ♥.</p>	High speed lock-out not disconnected	The vehicle was pre-set to run only in low speed. To allow the vehicle to run in low and high speed, you must disconnect the High Speed Lock-Out. Follow the instructions on page 22 to remove the High Speed Lock-Out screw.
When the foot pedal is pressed only one rear wheel spins	Operation of vehicle in low speed	It is possible that only one rear wheel may spin when both rear wheels are raised off the ground and the vehicle is in low speed. This does not necessarily indicate a problem. Check for proper operation of the drive system by raising the rear wheels off the ground and pressing the foot pedal. If only one rear wheel spins, carefully press your hand on the spinning wheel to slow it down. The other rear wheel should begin to spin. If the other rear wheel does not begin to spin, there may be a problem with the vehicle. Contact your local Power Wheels® authorized service center for diagnosis and repair.
Sometimes the vehicle doesn't run, but other times it does	Loose wire or connector	Check all wires around the motors and all connectors to make sure they are tight.
	Motor or electrical switch damage	Contact your local Power Wheels® authorized service center for diagnosis and repair.
When the foot pedal is pressed, the vehicle won't run without a push	Loose wire or connector	Check all wires around the motors and all connectors to make sure they are tight.
	"Dead Spot" on motor	Contact your local Power Wheels® authorized service center for diagnosis and repair.
Loud clacking or grinding noise from a motor-gearbox	Broken gears	Contact your local Power Wheels® authorized service center for diagnosis and repair.
Charger gets warm during use	It is normal for some chargers to get warm during use and is not reason for concern.	No action required.
		If your charger does not get warm during use, it does not mean that it is not working properly.
Battery makes a sizzling or gurgling noise when charging	It is normal for some battery to make noise and swell slightly while charging and is not reason for concern.	No action required.
		If your battery does not make noise or swell slightly during charging, it does not mean that it is not accepting the charge.

If, after reviewing the Problems and Solutions Guide, the vehicle still fails to operate, please contact your nearest authorized service center or contact Power Wheels® Consumer Relations toll-free at **1-800-348-0751**.

Hint! For faster service when calling Consumer Relations, completely charge the batteries before calling and have the following available by the phone:

- vehicle,
- vehicle model number (see sticker in battery compartment),
- vehicle production run number (see sticker in battery compartment).

N

Bumper-to-Bumper* Limited Warranty

***One year limited warranty from the date of purchase on the Power Wheels® vehicle.
Six month limited warranty on the 12 volt battery.**

For the original purchaser, this one year limited warranty covers the Power Wheels® ride-on vehicle (purchased from Power Wheels®) against defects in materials and work-manship. The six month limited warranty applies only to the 12 volt battery included by Power Wheels® with the original purchase of the vehicle.

This warranty covers normal use and does not cover the Power Wheels® vehicle or battery if damaged by unreasonable use, neglect, accident, abuse, misuse, improper service or other causes not arising out of defects in materials or workmanship. Evidence of any attempt at consumer repair will void this warranty. THIS WARRANTY DOES NOT COVER, AND IS INTENDED TO EXCLUDE, ANY LIABILITY ON THE PART OF POWER WHEELS®, WHETHER UNDER THIS WARRANTY OR IMPLIED BY LAW FOR ANY INDIRECT OR CONSEQUENTIAL DAMAGES FOR BREACH OF WARRANTY. SOME STATES DO NOT ALLOW THE EXCLUSION OR LIMITATION SO THIS LIMITATION MAY NOT APPLY TO YOU.

Should you need service or assistance with your vehicle during the warranty period, **do not return the vehicle to the store.** Power Wheels® has provided a nationwide network of authorized service centers. Power Wheels® is continually expanding our Authorized Service Center Network. If there is not an authorized service center in your area, please call Consumer Relations for information, **1-800-348-0751**.

THIS WARRANTY GIVES YOU SPECIFIC LEGAL RIGHTS, AND YOU MAY ALSO HAVE OTHER RIGHTS WHICH MAY VARY FROM STATE TO STATE.

PLEASE SAVE YOUR ORIGINAL SALES RECEIPT.

IMPORTANT!

DO NOT use this vehicle for the first time until you have charged the battery for 18 hours.

Remember to...

- ✓ Charge the battery immediately after each use.
- ✓ Charge the battery once a month during storage, even if the vehicle has not been used.

Failure to follow these instructions will permanently damage your battery and void your warranty. Please refer to the Battery Care Section in this manual for more information. For high speed operation, please refer to the "How to Operate Your Vehicle" section in this manual for more information.

DO NOT Return your Vehicle to the Store !



If you are missing parts or need assistance,
please call us toll-free:

Power Wheels® Consumer Relations

1-800-348-0751

8 AM - 6 PM EST, Monday through Friday.

Or contact your local, **independently owned and operated**
Power Wheels® Authorized Service Center.

For the location nearest you,
visit us on-line at www.powerwheels.com.



Fisher-Price, Power Wheels, and Power Wheels by Fisher-Price, Power Lock and Power Stick are U.S. trademarks of Mattel, Inc.

©2003 Mattel, Inc. All Rights Reserved. ® and ™ are registered trademarks of Mattel Inc.

Fisher-Price, Inc., a subsidiary of Mattel, Inc., East Aurora, New York 14052 U.S.A.