

This Owner's Manual is provided and hosted by [Appliance Factory Parts](http://www.appliancefactoryparts.com).

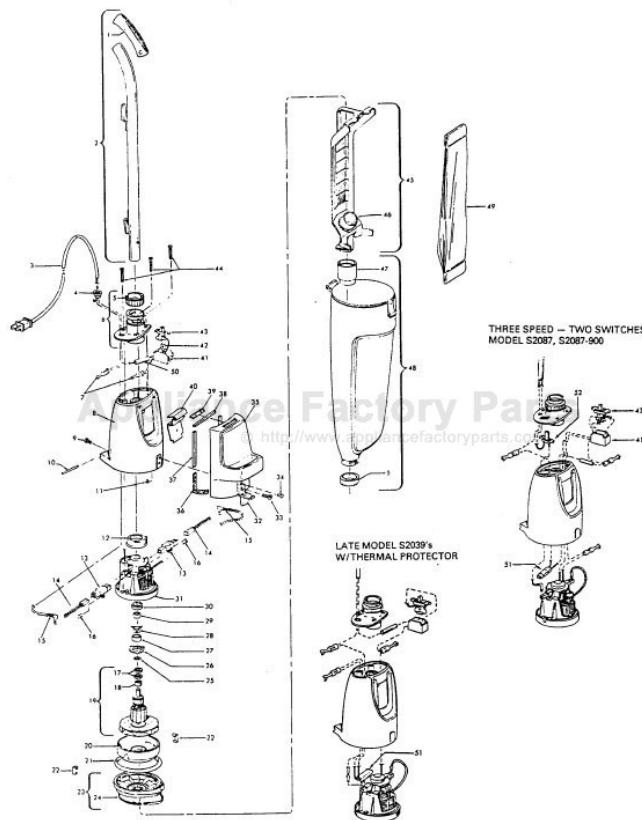

# HOOVER S2087 Owner's Manual

[Shop genuine replacement parts for HOOVER S2087](#)



[Find Your HOOVER Vacuum Cleaner Parts - Select From 1456 Models](#)

----- Manual continues below -----

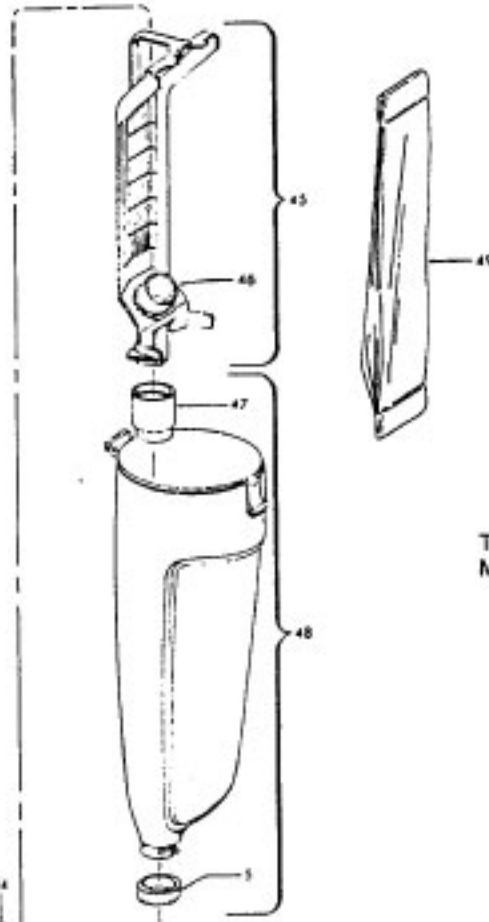
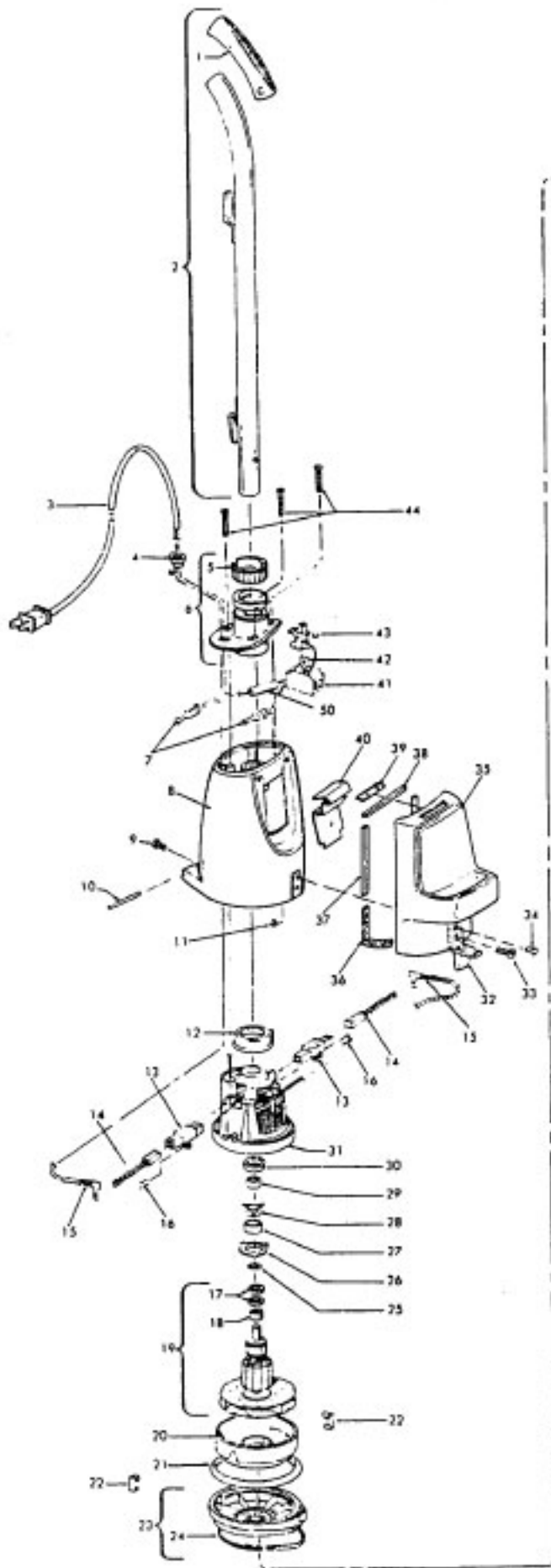

THREE SPEED - TWO SWITCHES  
MODEL S2087, S2087-900

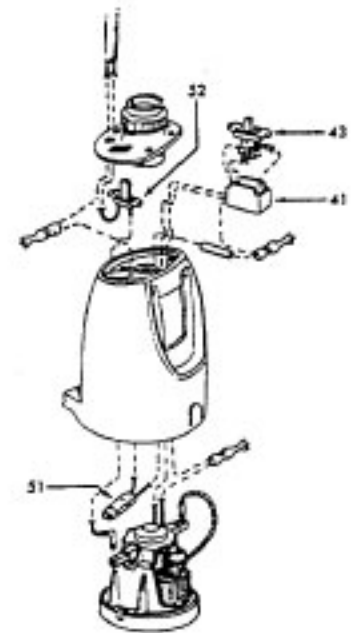

LATE MODEL S2039's  
W/THERMAL PROTECTOR



# Quik-Broom

# Model S2039, S2087, S2087-900

Ref.	Part	No.	No.
Description			
1	12230JM	+	Handle Grip
2	48646026	+	Handle/Grip Assm.
	48646066		Handle/Grip Assm. - S2087, S2087-900
3	46383068		Attach. Cord
4	163768		Strain Relief
5	36153009		Latch Ring
6	42227090		Closure Plate/Latch Ring
	42227086		Closure Plate/Latch Ring - S2087, S2087-900
7	12227		Insulated Terminal
8	42222100		Motor Housing Assm.
	42222010		Motor Housing Assm. - S2087, S2087-900
9	12954	*	Screw - Self Tapping
10	31514001		Hinge Pin
11	161549	+	Washer
	21312758	+	Washer - S2087, S2087-900
12	15316	+	Motor Mount
13	161749AG	+	Brush Holder
14	47311004		Motor Brush & Spring
15	161876	+	Terminal
16	162911	+	Screw
	21312759	+	Washer
	162910	+	Nut
17	15278	*	Fiber Washer
18	49344	+	Insulator
	31148006		Insulator - S2087, S2087-900
19	44731003		Armature & Fan
20	163441		Fan Housing & Bearing Assm.
21	15315	+	Motor Gasket
22	163416		Clip
23	19586AG	+	Bulkhead
24	15330	+	Bag Housing Gasket
25	21312719	+	Washer
26	15850	+	Bearing Retainer Support
27	12012	+	Absorbent Washer
28	15851	+	Bearing Retainer
29	24117209	+	Motor Bearing
30	15295	*	Felt Washer
31	45312033	+	Motor Case & Field Assm.
	43576075		Motor Case & Field Assm. - S2087, S2087-900
32	23715105		Latch
33	21447003	*	Screw - Self Tapping
34			Pop Rivet - 1/8" Dia. x 3/8" Long
35	48662006		Handle/Muffler Assm. (Incl. Items 36, 37,38,39,40)
	48662039		Handle/Muffler Assm. - S2087, S2087-900 (incl. Items 36,37,38,39,40)
36	34544001		Exhaust Diffuser - L. H.
	34544002		Exhaust Diffuser - R.H. (Shown)
37	34123013		Handle & Muffler Foam Seal (2)
38	34123012		Handle & Muffler Foam Seal
39	39383034		Indicator Lens - BU
40	51151045	+	Full Bag Indicator - BZ

Ref.	Part	No.	No.
Description			
41	37922002		Terminal Shield
42	27666702	*	Terminal
43	47517014		Hi-Low - Off Switch
	47517016		Switch (3 Speed) - S2087, S2087-900
44	15738EF	*+	Screw - Self Tapping
45	43615001		Cassette Assm.
46	43523001	+	Adapter Tube & Valve
47	32352001		Cassette Gasket
48	42223101		Bag Housing Assm. - JZ
	42223112		Bag Housing Assm. - MX - S2087, S2087-900
49	4010002E		Throw Away Bag - (3-Pk.)
50	31722007	*	Insulator
51	28382028		Thermal Protector
52	28178003		Switch (On-Off) - S2087, S2087-900

## ITEMS NOT ILLUSTRATED

43576021	+	Motor Assm. Comp. - Two Speed
43576067	+	Motor Assm. Comp. - Three Speed - S2087, S2087-900
52135017	+	Decal (Handle/Muffler Assm.)
52135034	+	Decal (Handle/Muffler Assm.) - S2087, S2087-900
21447026	+	Screw - Self Tapping (2) (Secures Item 35 Handle/Muffler Assm. to Item 8 Motor Housing Assm.)

## PACKAGING MATERIAL

58126051	+	Carton
58365002		Carton Support
56512053	+	Owner Manual
56512121	+	Owner Manual - S2087, S2087-900

# Rug & Floor Nozzle

Models S2001, S2003, S2009, S2011, S2039, S2041,  
S2087, S2087-900

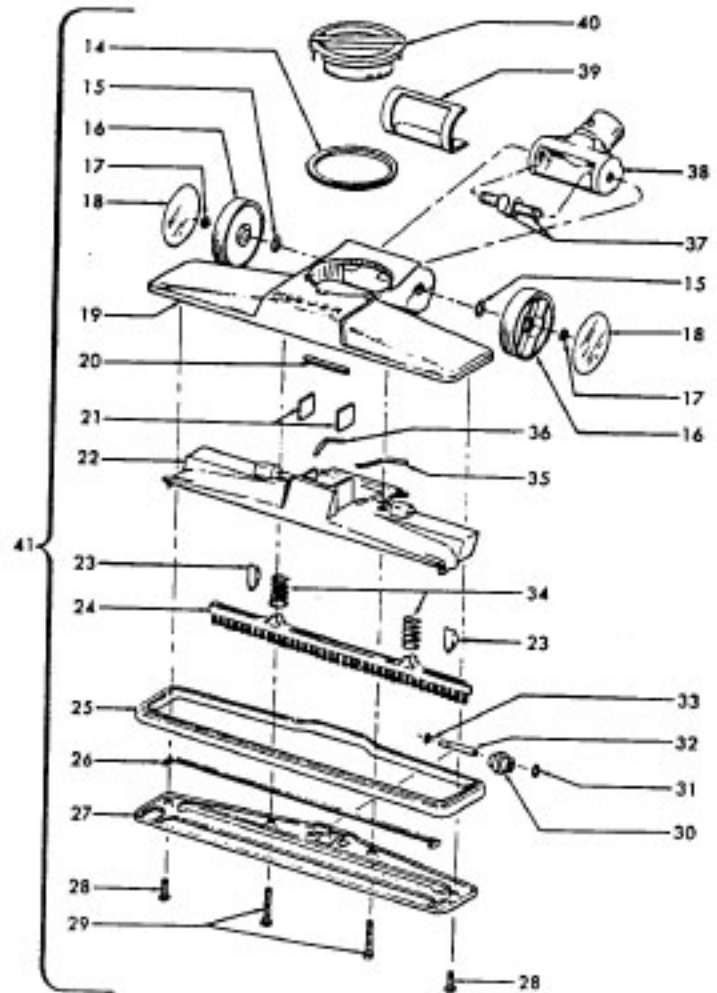
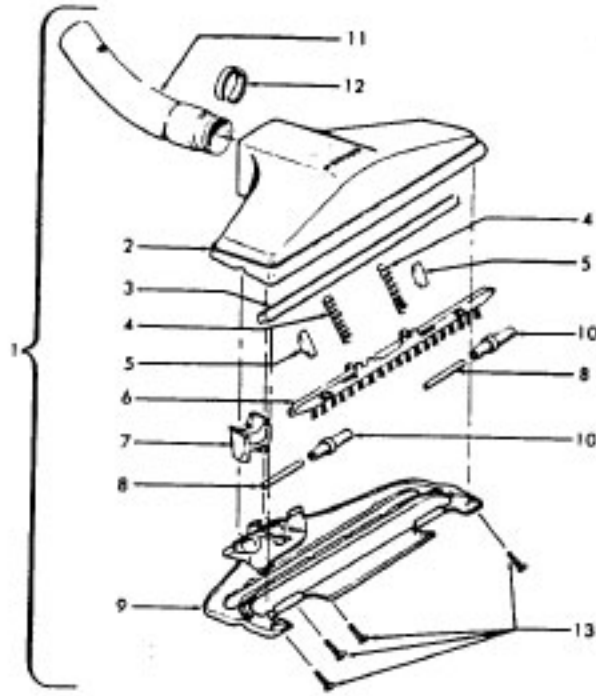

## Rug & Floor Nozzle

Model S2001, S2003, S2009, S2011,  
S2039, S2041, S2087, S2087-900

Ref. No.	Part No.	Description	Ref. No.	Part No.	Description
1	48476030	+ Rug & Floor Nozzle Comp. - CD - S2011	25	169247JM	+ Furniture Guard
	43414101	+ Rug & Floor Nozzle - AAP - S2003, S2041		169247AG	+ Furniture Guard
2	38615006	+ Nozzle - EK - S2003	26	169251	+ Gasket - S2001, S2009, S2039, S2087, S2087-900
	38615030	+ Nozzle - KZ - S2041	27	169538	+ Bottom Plate - S2001, S2009, S2039, S2087, S2087-900
	38615032	+ Nozzle - CD - S2011	28	21481464	+ Screw - S2001, S2009, S2039, S2087, S2087-900
3	16214	+ Gasket - S2003, S201 1, S2041	29	21481465	+ Screw - S2001, S2009, S2039, S2087, S2087-900
4	15963FW	+ Spring - S2003, S201 1, S2041	30	169243AG	Roller - S2001, S2009, S2039, S2087, S2087-900
5	13261AY	* Rib Shoe - S2003, S201 1, S2041	31	21312758	+* Washer - S2001, S2009, S2039, S2087, S2087-900
6	16184	Brush Back - S2003, S201 1, S2041	32	169244AW	Roller Shaft - S2001, S2009, S2039, S2087, S2087-900
7	161413	+* Tube Retainer - S2003, S2011, S2041	33	24735081	* Lock Ring - S2001, S2009, S2039, S2087, S2087-900
8	13272	+ Roller Shaft - S2003, S201 1, S2041	34	166649FW	Spring - S2001, S2009, S2039, S2087, S2087-900
9	42246002	+ Bottom Plate - S2003, S201 1, S2041	35	34513001	Seal - L.H. - S2001, S2009, S2039, S2087, S2087-900
10	13157AG	+ Roller - S2003, S201 1, S2041	36	34513002	Seal - R.H. - S2001, S2009, S2039, S2087, S2087-900
11	16269JM	Connector Tube	37	169240AY	+ Wheel Shaft - S2001, S2009, S2039, S2087, S2087-900
12	13267	+* Gasket - S2003, S201 1, S2041	38	169249JM	+ Connector Tube
13	12955	* Screw - S2003, S201 1, S2041	39	34122006	Seal- S2001, S2009, S2039, S2087-900
14	34113001	+ Seal- S2001, S2009, S2039	40	169254JM	+ Suction Control Knob
15	169241AW	* Washer - S2001, S2009, S2039, S2087, S2087-900	41	169254MX	+ Suction Control Knob
16	169239AG	Wheel		43414101	+ Rug/Floor Nozzle
17	13730	* Lock Ring - S2001, S2009, S2039, S2087, S2087-900		48476053	+ Rug/Floor Nozzle Comp. - JZ
18	169242	Wheel Cover - S2001, S2009, S2039, S2087, S2087-900			
19	38615101	Nozzle - S2001, S2009, S2039			
	38615164	Nozzle - MX - S2087, S2087-900			
20	34112001	* Seal - S2001, S2009, S2039, S2087, S2087-900			
21	34223002	+ Seal - S2001, S2009, S2039, S2087, S2087-900			
22	169250AG	+ Brush Housing - S2001, S2009, S2039, S2087, S2087-900			
23	169253AY	+* Rib Shoe - S2001, S2009, S2039, S2087, S2087-900			
24	169256	+ Brush Back - S2001, S2009, S2039, S2087, S2087-900			