

# ASSEMBLY & OPERATING INSTRUCTIONS

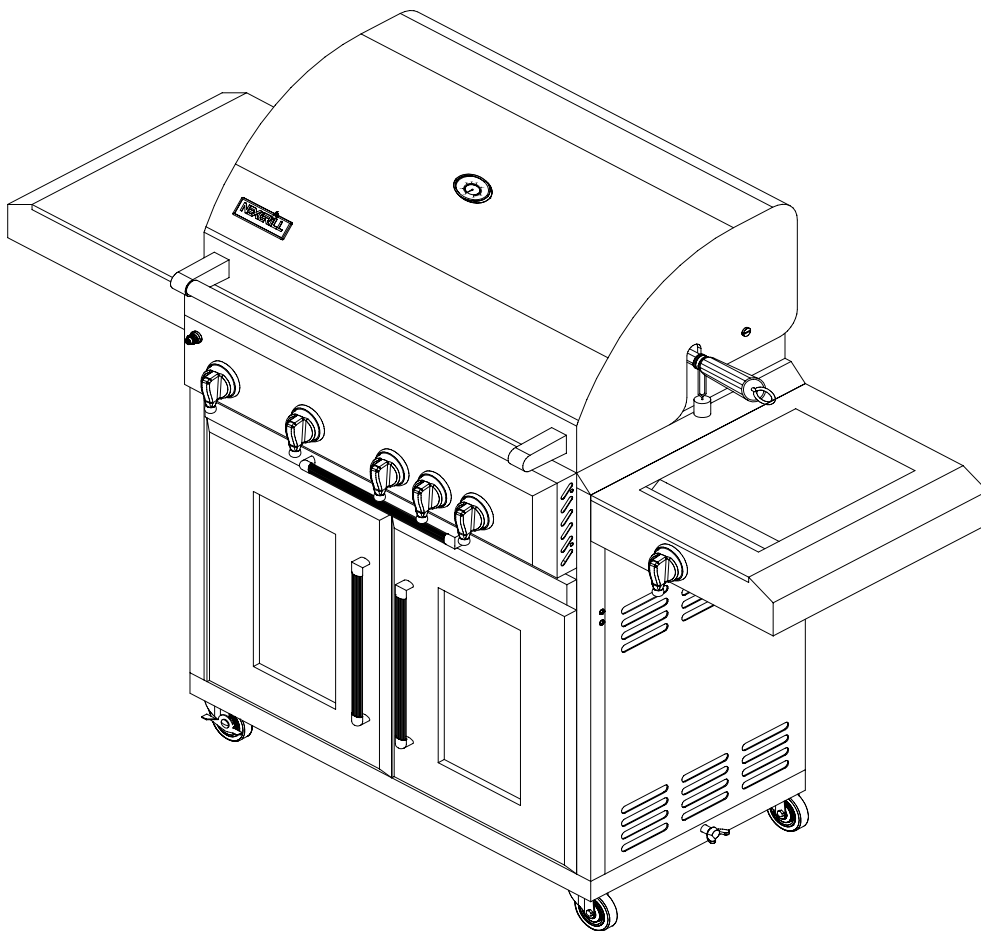

*Model: 730-0439*  
*natural Gas Use only*

FOR OUTDOOR USE ONLY

J23Y06N-1

**PLEASE CONTACT 1-800-984-7455 FOR ASSISTANCE  
ABOUT ASSEMBLY OR GRILL OPERATION  
DO NOT RETURN TO THE PLACE OF PURCHASE**

# TABLE OF CONTENTS

**SECTION ONE:**

Table of Contents & Importance -----1  
 Precautions-----2-5

**SECTION TWO:**

Assembly Instruction-----6-10  
 To Match Light the Grill-----11  
 Operating Instructions-----12

**SECTION THREE:**

Lighting Instructions-----13-14  
 Lighting Illustrations-----15

**SECTION FOUR:**

Cleaning & Maintenance-----16  
 Trouble Shooting-----17-20

**SECTION FIVE:**

Exploded View-----21  
 Grill Parts List -----22

**SECTION SIX:**

Grilling Hints-----23  
 Grill Cooking Chart-----24-25  
 Grill Recipe Suggestions-----26-28

**SECTION SEVE:**

Limited Warranty-----29

## IMPORTANCE



**\*\*\*\*\* WARNING \*\*\*\*\***

<p style="text-align: center;"> <b>Danger</b></p> <p>If you smell gas:</p> <ol style="list-style-type: none"> <li>1. Shut off gas to the appliance.</li> <li>2. Extinguish any open flame.</li> <li>3. Open lid</li> <li>4. If odor continues, keep away from appliance and immediately call your gas supplier or your fire department.</li> </ol>	<p style="text-align: center;"> <b>Warning</b></p> <p>Do not store or use gasoline or other flammable vapors and liquids in the vicinity of this or any other appliance.</p>
<p style="text-align: center;"><b>WARNING</b></p> <p>Combustion byproducts produced when using this <b>product contain chemicals known to the State of California</b> to cause cancer, birth defects, or other reproductive harm.</p>	<p style="text-align: center;"><b>WARNING</b></p> <p>Failure to comply with these instructions could result in a fire or explosion that could cause serious bodily injury, death, or property damage.</p>
<p style="text-align: center;"><b>WARNING</b></p> <p><b>Your grill will get very hot.</b> Never lean over the cooking area while using your grill. Do not touch cooking surfaces, grill housing, Lid or any other grill parts while the grill is in operation, or until the gas grill has cooled down after use.</p> <p><b>Keep any electrical supply cord and the fuel supply hose away from any heated surfaces.</b></p> <p><b>Failure to comply with these instructions may result in serious bodily injury or death.</b></p>	

# PRECAUTIONS

## WARNING

Do not try lighting this appliance without reading the "LIGHTING INSTRUCTIONS" section of this manual.

TESTED IN ACCORDANCE WITH ANSI Z21.58 CSA 1.6 STANDARD FOR OUTDOOR COOKING GAS APPLIANCES. THIS GRILL IS FOR OUTDOOR USE ONLY.

## Grill Installation Codes

The installation must conform with local codes or, in the absence of local codes, with either the national fuel gas code, ANSIZ 223.1/NFPA 54, Natural gas and Propane installation code, CSA B149.1, or Propane Storage and Handling Code, B149.2, or the Standard for Recreational Vehicles, ANSI A 119.2/NFPA 1192, and CSA Z240 RV series Recreational Vehicle Code, as applicable.

**If an external electrical source is utilized:** The outdoor cooking gas appliance, when installed, must be electrically grounded in accordance with local codes or, in the absence of local codes, with the National Electrical Code, ANSI/NFPA 70, or the Canadian Electrical Code, CSA C22.1.

## WARNING

Keep any electrical supply cord and the fuel supply hose away from any heated surfaces.

## CAUTION: Beware of Flashback

**CAUTION:** Spiders and small insects occasionally spin webs or make nests in the grill burner tubes during transit and warehousing. These webs can lead to gas flow obstruction, which could result in a fire in and around burner tubes. This type of fire is known as "FLASH-BACK" and can cause serious damage to your grill and create an unsafe operating condition for the user.

Although an obstructed burner tube is not the only cause of "FLASH-BACK", it is the most common cause.

To reduce the chance of "FLASH-BACK", you must clean the burner tubes before assembling your grill, and at least once a month in late summer or early fall when spiders are most active. Also perform this burner tube cleaning procedure if your grill has not been used for an extended period of time. A clogged tube can lead to a fire beneath the grill.

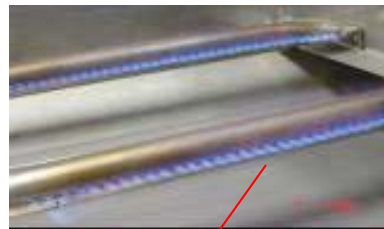

Visually check the burner flames prior to each use, the flames should look like this picture, if they do not, refer to the burner main tenancy part of this manual.

# PRECAUTIONS

## WARNING

Your grill will get very hot. Never lean over the cooking area while using your grill. Do not touch cooking surfaces, grill housing, Lid or any other grill parts while the grill is in operation, or unit the gas grill has cooled down after use.

**Failure to comply with these instructions may result in serious bodily injury.**

## ROTISSERIE DRIVE MOTOR

USE ONLY FOR OUTDOORS, DO NOT EXPOSE TO RAIN.

**CAUTION:** TO ENSURE CONTINUED PROTECTION AGAINST RISK OF ELECTRIC SHOCK, CONNECT TO PROPERLY GROUNDED OUTLETS ONLY, TO REDUCE THE RISK OF ELECTRIC SHOCK, KEEP EXTENSION CORD CONNECTION DRY AND OFF THE GROUND.

## INSPECT WARNING:

Spiders and insects can nest in the burners of this and any other grill, and cause the gas to flow improperly. This is a very dangerous condition, which can cause a fire to occur behind and beneath the valve panel, thereby damaging the grill and making it unsafe to operate. Inspect the grill twice a year.

## WARNING

**ELECTRICAL GROUNDING INSTRUCTIONS:**  
**This appliance (rotisserie motor) is equipped with a plug and should be plugged directly into a properly grounded receptacle. DO NOT cut or remove the grounding prong from this plug.**

Keep the rotisserie motor electric cord away from the heated surfaces of the grill. When not in use remove and store the motor in a dry location.

## WARNING

Keep a spray bottle of soapy water near the gas supply valve and check the connections before each use.

**DO NOT USE ALUMINUM FOIL TO LINE THE GRILL RACKS OR GRILL BOTTOM.**

This can severely upset combustion airflow or trap excessive heat in the control area.

**DO NOT LEAVE THE GRILL UNATTENDED WHILE COOKING.**

## PROPER PLACEMENT AND CLEARANCE OF GRILL

•**Never** use your gas grill in a garage, porch, shed, breezeway or any other enclosed area. Your gas grill is to be used **outdoors only**. Minimum clearance from sides and back of unit to combustible construction, 24 inches (61cm) from sides and 24 inches (61cm) from back.

•**DO NOT** use this appliance under overhead combustible surfaces. This outdoor cooking gas appliance is not intended to install in or on recreational vehicles and/or boats.

•Do not obstruct the flow of ventilation air around the gas grill housing. Only use the regulator and the hose assembly supplied with your gas grill. Replacement regulators and hose assemblies must be those specified in this manual.

•The regulator and hose assembly must be inspected before each use of the grill. If there is excessive abrasion or wear or if the hose is cut, it must be replaced prior to the grill being put into operation. Keep the fuel supply hose away from any heated surfaces and dripping grease.

•Avoid unnecessary twisting of hose. Visually inspect the hose prior to each use for cuts, cracks, excessive wear or other damage. If the hose appears damaged do not use the gas grill.

•**Never** light your gas grill with the lid closed or before checking to ensure the burner tubes are fully seated over the gas valve orifices.

•**Never** allow children to operate your grill.

•**DO NOT USE BRIQUETTES OF ANY KIND IN THE GRILL.**

•The grill is designed for optimum performance without the use of briquettes. Do not place briquettes on the radiant as this will block off the area for the grill burners to vent. Adding briquettes can damage ignition components and knobs, and void the warranty.

•Keep the back and side free and clear from debris. Keep any electrical supply cord, or the rotisserie motor cord away from the heated areas of the grill.

•Never use the grill in extremely windy conditions. If located in a consistently windy area (oceanfront, mountaintop, etc.) a windbreak will be required (see below). Always adhere to the specified clearance.

## Warning

A statement that this outdoor cooking gas appliance is not intended to be installed in or on boats. For other than RV grills, a statement that this appliance is not intended to be installed in or on recreational vehicles.

## PRECAUTIONS

### SAFETY PRACTICES TO AVOID PERSONAL INJURY

When properly cared for, your grill will give safe, reliable service for many years. However, extreme care must be used since the grill produces intense heat and that can increase accident potential. When using this appliance basic safety practices must be followed, including the following:

Do not repair or replace any part of the grill unless specifically recommended in this manual. All other service should be referred to a qualified technician.

**This outdoor cooking gas appliance is not intended to install in or on recreational vehicles and/or boats.**

CHILDREN SHOULD NOT BE LEFT ALONE OR UNATTENDED IN AN AREA WHERE THE GRILL IS BEING USED. NEVER ALLOW THEM TO SIT, STAND OR PLAY ON OR AROUND THE GRILL AT ANY TIME.

*DO NOT STORE ITEMS OF INTEREST TO CHILDREN AROUND OR BELOW THE GRILL OR IN THE ISLAND. NEVER ALLOW CHILDREN TO CRAWL INSIDE OF THE ISLAND.*

Never let clothing, kitchen mitten or other flammable materials come in contact with or too close to any grate, burner or hot surface until it has cooled. Fabric may ignite and result in personal injury.

For personal safety, wear proper apparel. Loose fitting garments or sleeves should never be worn while using this appliance. Some synthetic fabrics are highly flammable and should not be worn while cooking.

Only certain types of glass, heatproof glass ceramic, earthenware, or other glazed utensils are suitable for grill use. These types of materials may break with sudden temperature changes. Use only on low or medium heat settings according to the manufacturer's directions.

Do not heat unopened food containers as a build-up of pressure may cause the container to burst.

Use a covered hand when opening the grill lid. Never lean over an open grill.

WHEN LIGHTING A BURNER, ALWAYS PAY CLOSE ATTENTION TO WHAT YOU ARE DOING. BE CERTAIN YOU ARE TURNING THE IGNITER LABELED FOR THE BURNER YOU INTEND ON USING.

When using the grill, do not touch the grill rack, burner grate or immediate surroundings as these areas become extremely hot and could cause burns. Use only dry potholders. Moist or damp potholders on hot surfaces may cause burns from steam. Do not use a towel or bulky cloth in place of potholders. Do not let potholders touch hot portions of the grill rack.

Grease is flammable. Let hot grease cool before attempting to handle it. Avoid letting excess grease deposits collect in the grease tray at the bottom of the grill's firebox. Clean often.

For proper lighting and performance of the burners keep the burner ports clean. It is necessary to clean them periodically for optimum performance. The burners will only operate in one position and must be mounted correctly for safe operation.

Clean the grill with caution. Avoid steam burns; do not use a wet sponge or cloth to clean the grill while it is hot. Some cleaners produce noxious fumes or can ignite if applied to a hot surface.

Be sure all grill controls are turned off and the grill is cool before using any type of aerosol cleaner on or around the grill. The chemical that produces the spraying action could, in the presence of heat, ignite or cause metal parts to corrode.

Do not use the grill for cooking excessively fatty meats or products, which promote flare-ups. Do not operate the grill under unprotected combustible construction. Use only in well ventilated areas. Do not use in buildings, garages, sheds, breezeways or other such enclosed areas. **THIS UNIT IS FOR OUTDOOR USE ONLY.**

Keep the area surrounding the grill free from combustible materials, trash, or combustible fluids and vapors such as gasoline or charcoal lighter fluid. Do not obstruct the flow of combustion and ventilation air.

## PRECAUTIONS

### CHECKING FOR GAS LEAKS

Never test for leaks with a flame. Prior to first use and at the beginning of each new season, you must check for gas leaks.

Follow these steps:

1. Make soap solution by mixing one part liquid detergent and one part water.

2. Turn off heat control valves, and then turn on gas at source.

3. Apply the soap solution to all gas connections. Bubbles will appear in the soap solution if connections are not properly sealed. Tighten or repair as necessary.

4. If you have a gas leak that you cannot repair, turn off the gas at the source, disconnect the fuel line from grill and immediately call your grill dealer or gas supplier for professional assistance.

Total gas consumption (per hour) of grill with all burners on "HI".

3 Main Burners	30,000 BTU/HR.
1 Searing Main Burner:	15,000 BTU/HR.
1 Side Burner:	12,000 BTU/HR.
1 Rear Burner:	10,000 BTU/HR.
Total:	67,000 BTU/HR.

### NATURAL GAS SAFETY

Your natural gas is designed to operate on natural gas grill only, at a pressure of 4" water column (1/4 psig or 1.75 kpa) regulated at the pre-set supplied regulator. Check with your gas utility for local gas pressure and with your local municipality for building code requirements. If your residential gas utility line pressure has not been regulated to 7" W.C. contact your local gas utility or gas grill dealer for professional assistance.

Check with your gas utility or with local building codes for instructions to install gas supply line, or call a licensed and knowledgeable installer. It is recommended that an "ON-OFF" shut off valve be installed at the gas supply source; outdoors after the gas line piping exits outside the wall and before the quick-disconnect. In a branch fuel line, it should be installed before the

gas line piping enters the ground indoors in an accessible location near the supply line.

Pipe sealing compound or pipe thread tape of the type resistant to the action of natural gas must be used on all male pipe threads when making the connection.

Disconnect your gas grill from its fuel source when the gas company is testing the gas supply lines at high pressures. This appliance and its individual shut off valve must be disconnected from the gas supply piping system during any pressure testing of that system at pressure in excess of 1/2 psi (3.5 kpa).

Turn off your gas grill when the gas company is testing the gas supply at low pressures. This appliance must be isolated from the gas supply piping system by closing its individual manual shut off valve during any pressure testing of the gas supply piping system at pressures equal or less than 1/2 psi (3.5kpa).

# ASSEMBLY INSTRUCTIONS

**PLEASE READ THE INSTRUCTIONS CAREFULLY AND FOLLOW STEP BY STEP.**

**TOOLS REQUIRED:**

**(1) PHILIPS HEAD SCREWDRIVER – NOT PROVIDED**

**STEP 1:**

A. The screws used to attach the side shelf are already screwed into the left panel (see the figure below). Remove the screws from the left panel, align with the holes in the side shelf, and then re-screw into the holes on the left panel of the grill.

B. The screws used to attach the side burner are already screwed into the right panel (see the figure below). Remove the screws from the right panel, align with the holes in the side burner, and then re-screw into the holes on the right panel of the grill.

**Screw size: 1/4 x 10mm  
Washer size: 1/4**

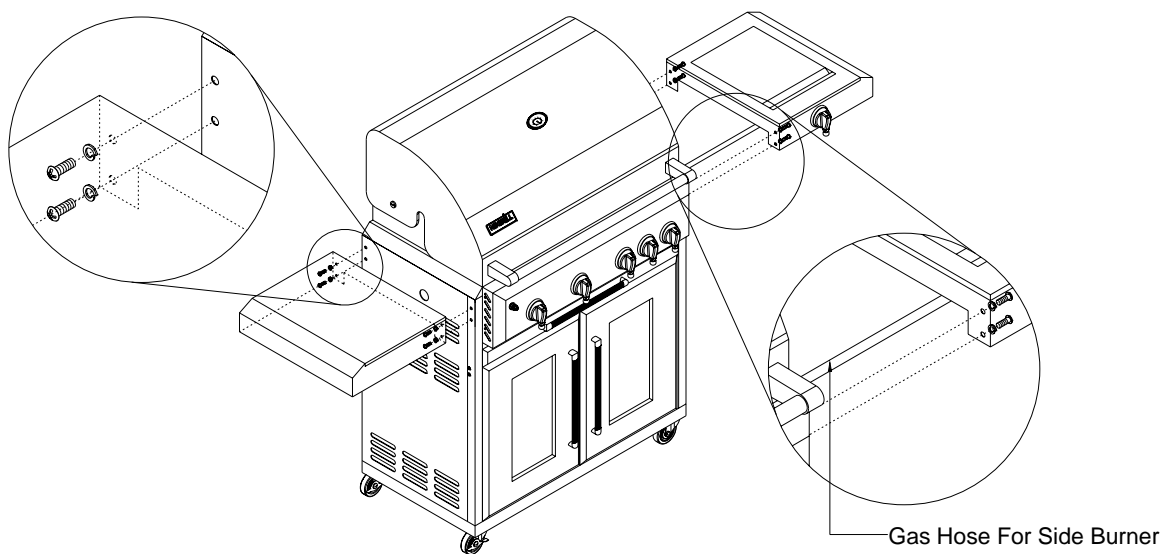

# ASSEMBLY INSTRUCTIONS

## STEP 2: Side Burner Assembly

A. Push valve into side burner control panel. Insert screws from the front side of control panel and tighten.

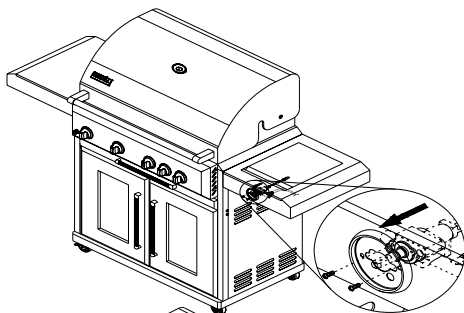

B. Push the side burner control knob into the valve stem and tighten it using the Allen Wrench.

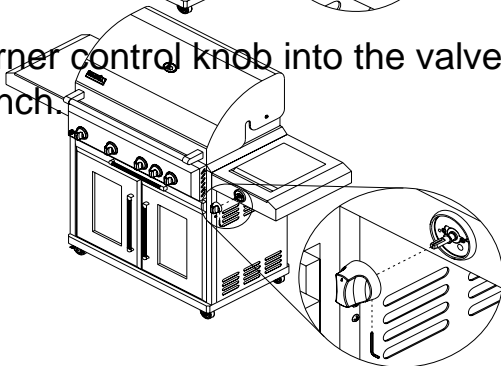

C. Insert valve venturi into the side burner and tighten securely using an adjustable wrench.

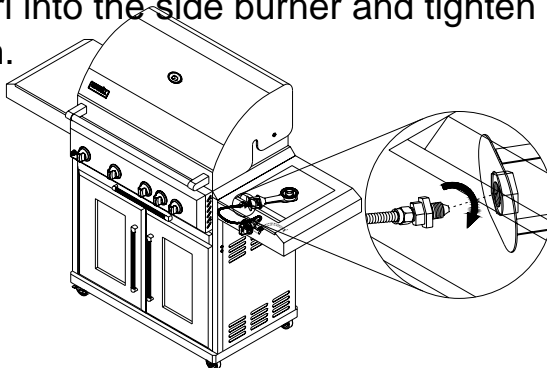

D. Connect ignition wire with valve.

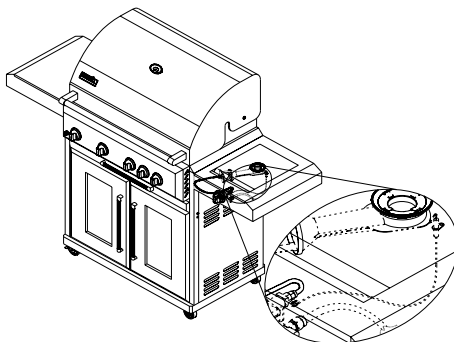



## ASSEMBLY INSTRUCTIONS

STEP 3: Battery is inserted for the rotisserie burner . To install the battery, turn the ignition button cap counterclockwise and remove it. Replace the ignition button cap after the battery is installed.

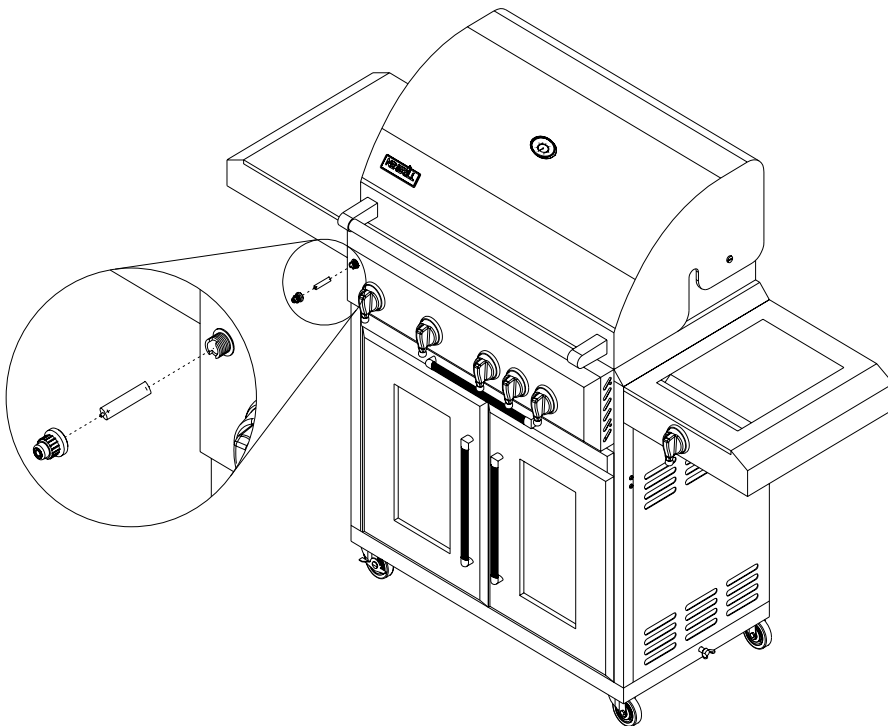

## ASSEMBLY INSTRUCTIONS

**STEP 4:** The screws for rotisserie drive motor bracket are attached to the motor bracket. Remove the screws and install the rotisserie motor bracket as shown in the figure below. Assemble the rotisserie skewer as shown in the figure below.

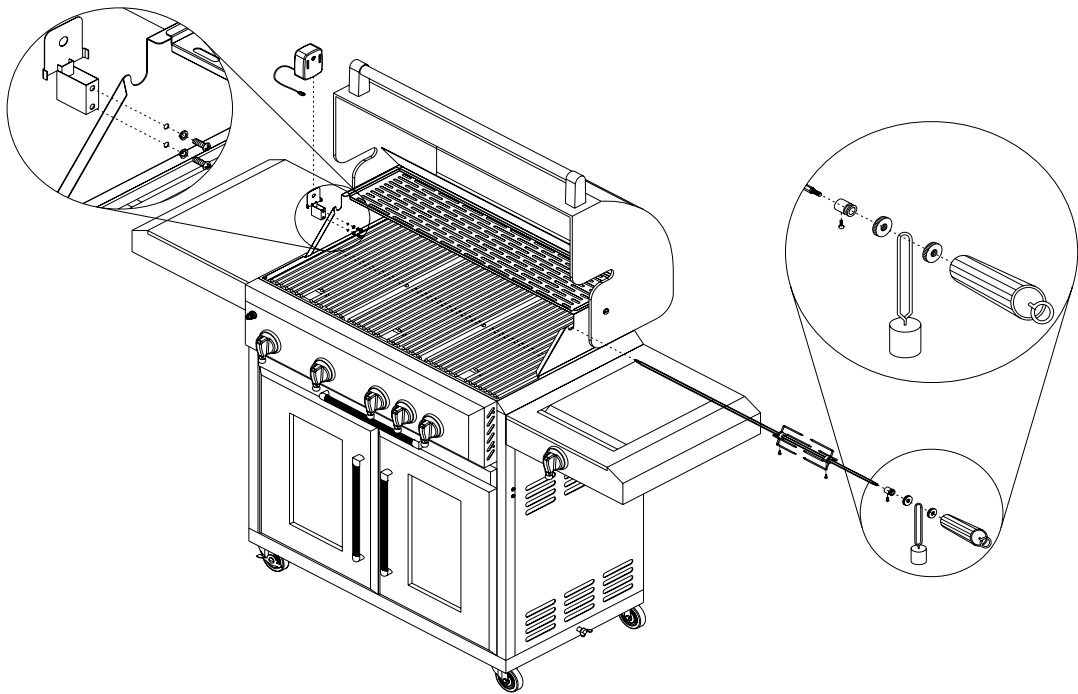

## ASSEMBLY INSTRUCTIONS

**STEP 5:** The Nature Gas regulator has been installed on the unit. Attach the PVC Gas Hose to the regulator (See drawing below). Connect the other end of the PVC Gas Hose to the house gas line.

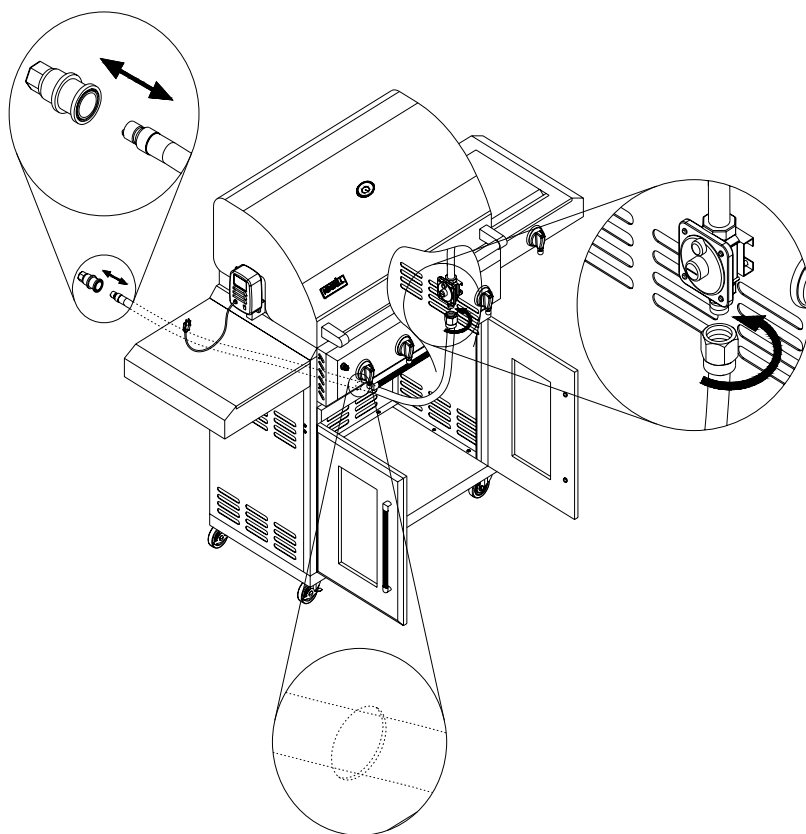

## TO MATCH LIGHT THE GRILL

1.If the burner will not light after several attempts then the burner can be match lit.

2.If you've just attempted to light the burner with the igniter, allow 5 minutes for any accumulated gas to dissipate. Keep your face and hands as far away from the grill as possible. Insert a lit extended match or lighter through the cooking grids to the burner. Press the control knob and rotate left to the HI setting, continue to press the knob until the burner ignites. Burner should light immediately. If the burner does not light in 4 seconds turn the knob off, wait 5 minutes and try again.

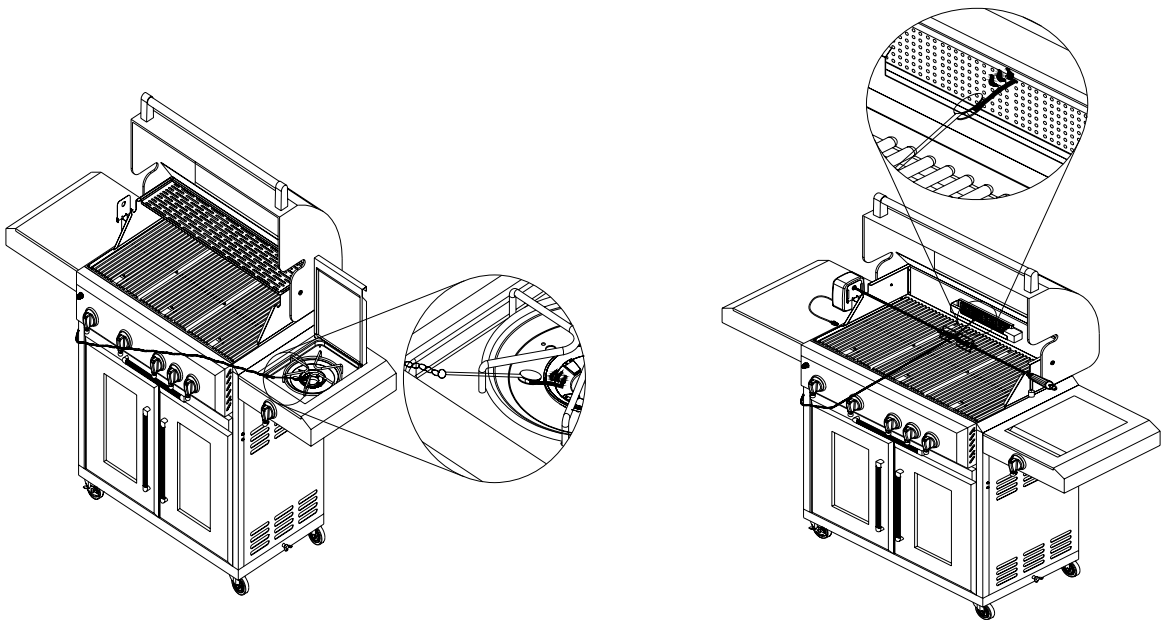
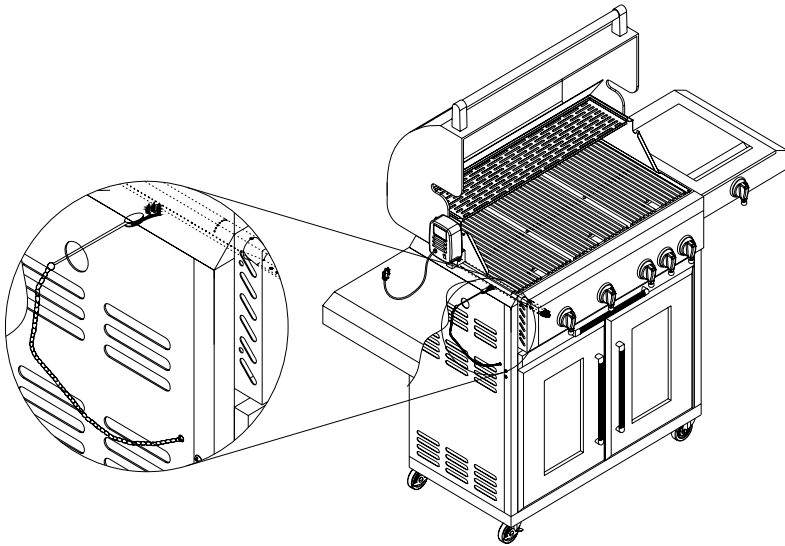

# OPERATING INSTRUCTIONS

## GENERAL USE OF THE GRILL AND ROTISSERIE

Each main burner is rated at 10,000 Btu/hr. The main grill burners encompass the entire cooking area and are side ported to minimize blockage from falling grease and debris. Above the burners are stainless steel radiant (flame tamer). The igniter knobs are located on the lower center portion of the valve panel. Each rotary igniter is labeled on the control panel.

## USING THE GRILL

Grilling requires high heat for searing and proper browning. Most foods are cooked at the "HI" heat setting for the entire cooking time. However, when grilling large pieces of meat or poultry, it may be necessary to turn the heat to a lower setting after the initial browning. This cooks the food through without burning the outside. Foods cooked for a long time or foods basted with a sugary marinade may need a lower heat setting near the end of the cooking time.

NOTE: This stainless steel grill is designed to grill efficiently without the use of lava rocks or briquettes of any kind. Heat is radiated by the stainless steel flame tamers positioned above each burner.

NOTE: The hot grill sears the food, sealing in the juices. The longer the preheat, the faster the meat browns and the darker the grill marks.

**DO NOT LEAVE THE GRILL UNATTENDED WHILE COOKING.**

## WARNING: IMPORTANT! USING THE SIDE BURNER:

Inspect the gas supply hose prior to turning the gas "ON". If there is evidence of cuts, wear or abrasion, it must be replaced prior to use. Do not use the side burner if the odor of gas is present.

## USING ROTISSERIE BURNER

Your grill is capable of performing back burner rotisserie cooking. Light the rear burner as described in the lighting instructions, see page 20. Once lit, the rotisserie burner will reach cooking temperatures in about 1 minute.

**CAUTION: PLEASE TAKE OFF THE WARMING RACK WHEN USING THE ROTIS BURNER. THE HIGH HEAT COMING FROM THE ROTIS BURNER MAY CAUSE THE WARMING RACK TO BEND.**

## WARNING: IMPORTANT! BEFORE LIGHTING...

Inspect the gas supply hose prior to turning the gas "ON". If there is evidence of cuts, wear, or abrasion, it must be replaced prior to use. Do not use the grill if the odor of gas is present. Only the pressure regulator and hose assembly supplied with the unit should be used.

## GRILL LIGHTING INSTRUCTIONS

**WARNING:** Always keep your face and body as far away from the burner as possible when lighting.

### TO LIGHT THE SIDE BURNER

To light the side burner, remove any cooking utensils from the burner grate. Push and turn the control knob counterclockwise to the “HI/Light” position. If the burner does not light, turn the control

knob to “OFF”. If the smell of gas is detected and the igniter is not functioning, immediately turn the control knob “OFF”. Allow 5 minutes for any accumulated gas to dissipate. If the side burner igniter is not functioning, see the following section for match lighting.

### TO MATCH LIGHT THE GRILL

If the burner will not light after several attempts then the burner can be match lit.

Lighting rod-Here is your instruction:

Match light extension rod

Use this device to match light your burners

Simply place a lighted match between the coils on the end of the extension rod and hold next to the burner to ignite.

If you’ve just attempted to light the burner with the igniter, allow 5 minutes for any accumulated gas to dissipate. Keep your face and hands as far away from the grill as possible. Insert a lit match attached to tight lighting rod or lighter through the cooking grids to the burner.( see next page) Press the control knob and rotate left to the HI/Light setting, continue to press the knob until the burner ignites. Burner should light immediately. If the burner does not light in 4 seconds turn the knob off, wait 5 minutes and try again.

### TO MATCH LIGHT THE SIDE BURNER

Hold a lit extended match or lighter near the side burner ports, turn the control knob counterclockwise to “HI/Light”. Move your hand immediately once the burner is lit. Rotate the control knob to the desired setting.

**Keep a spray bottle of soapy water near the gas supply valve and check the connections before each use.**

**Do not attempt to light the grill if odor of gas is present. Call for service 1-800-984-7455**

# GRILL LIGHTING INSTRUCTIONS

## FLAME CHARACTERISTICS

Check for proper burner flame characteristics.

Burner flames should be blue and stable with no yellow tips, excessive noise, or lifting. If any of these conditions exist call our customer service line. If the flame is yellow, it indicates insufficient air. If the

flame is noisy and tends to lift away from the burner, it indicates too much air.

**Each burner is adjusted prior to shipment; however, variations in the local gas supply may take minor adjustments necessary.**

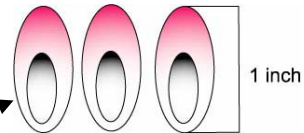

Visually check the burner flames prior to each use, The flames should look like this picture, if they do not, refer to the burner maintenance part of this manual



*Approximate 1 1/2 " Flame Height*

# LIGHTING ILLUSTRATION

## Main & Side Burner Lighting illustration

Step 1.

Make sure the Lid is open



Step 2.

Push and turn main or side burner knobs to "IGNITE/HI" position. Pilot torch will light. Hold for 3-4 seconds until burner is lit.



Step 3.

You may need to try 3 or 4 times to light the burner. After the burner is lit, adjust the knob as desired.



## Rotisserie Burner Lighting Illustration

### Step to light the Rotisserie Burner:

Push and turn the rear burner knob to "IGNITE/HI" position and hold for 3-4 seconds and push electronic ignition button, until burner is lit. Once it is lit, release electronic ignition button, and continue hold the rear burner knob in for another 15 seconds to keep the burner lit



### Step to light the Searing Burner:

Push and turn the Searing knob to "IGNITE/HI" position and hold for 3-4 seconds and push electronic ignition button, until burner is lit. Once it is lit, release electronic ignition button, and hold the Searing knob for another 15 seconds to be sure the burner stay lit.





## CLEANING & MAINTENANCE

### CLEANING THE COOKING GRIDS

After cooking, turn control knobs to “OFF” and let grill cool before attempting to clean your cooking grids.

Before first use and periodically it is suggested that you wash the cooking grids in a mild soap and warm water solution. You can use a washcloth, a vegetable brush or a steel wool to clean your cooking grids if you desire.

### CLEANING THE FLAME TAMER

Washing the flame tamer after every use is not necessary but periodically it is suggested you wash the tamer in a soap and warm water solution. Use a wire brush to remove stubborn burnt on cooking residue. Dry the flame tamer thoroughly before you re-install into the grill housing.

### CLEANING THE BURNER TUBES AND BURNER PORTS (TO PREVENT FLASH-BACK) SPIDER AND INSECT WARNING!!!

Spiders and insects can nest in the burners of this or any other grill, and cause the gas to flow from the front of the burner. This is a very dangerous condition, which can cause a fire to occur behind the valve panel (flash back), thereby damaging the grill and making it unsafe to operate. We recommend that you inspect for spiders regularly in late summer or early fall when they are most active.

To inspect for spiders:

1. Turn the burner valve off.
2. Turn the gas supply off fully (Turn clockwise to stop).
3. Remove cooking grids, flame tamers.
4. Unscrew and remove the burners from the grill housing.
5. Carefully lift each burner up and away from gas valve orifice. Inspect for any obstructions and use air pressure or a clean plastic brush to clear the burner tube or any debris.
6. Carefully replace the burner in its exact position directly in front of gas valve orifice.

### BURNER CLEANING

1. Wire brush entire surface of burner to remove food residue and dirt.
2. Clean any clogged ports with a stiff wire such as an open paper clip.
3. Inspect the burner for damage (cracks or holes) and if such damage is found, order and install a new burner. After installation check to insure the gas valve orifices are correctly placed inside the ends of burner tubes. Also check the position of the spark electrode.

### CLEANING THE GREASE TRAY

The grease tray should be emptied and wiped done periodically and washed in a mild detergent and warm water solution. A small amount of sand or cat litter may be placed in bottom of grease tray to absorb the grease

### ANNUAL CLEANING OF GRILL HOUSING

Burning-off the grill after every cook out will keep it ready for instant use; however once a year minimum you should give the entire grill a thorough cleaning to keep it in tip operating condition

### INTERIOR:

1. Turn the burner valve off.
2. For NG turn the safety valve to off
3. Remove and clean the cooking grids, flame tamers.
4. Brush the inside and bottom of the grill with a stiff wire brush, and wash down with a mild soap and warm water solution. Rinse thoroughly and let dry.
5. Check spark electrode, adjusting as instructed. Electrode tip pointing toward the tip of gas collector and approximately 3/16” from the tip of collector tube
6. Replace flame tamers cooking grids.
7. Reconnect to the gas source and observe the burner flame for correct operation.

### IMPORTANT:

You should NOT line the bottom of the grill housing with aluminum foil, sand or any other grease-absorbent substance. Grease will not be able to drip down into grease collector and a grease fire could occur.

Your gas grill is made of heavy stainless steel; it should provide you with years of trouble-free service.

## TROUBLE SHOOTING

### **SPIDER AND INSECT WARNING!!!**

Spiders and small insects occasionally spin webs or make nests in the grill burner tubes during transit and warehousing.

These webs can lead to gas flow obstruction which could result in a fire in and around burner tubes. This type of fire is known as “FLASH-BACK” and can cause serious damage to your grill and create an unsafe operating condition for the user.

Although an obstructed burner tube is not the only cause of “FLASH-BACK”, it is the most common cause.

To reduce the chance of “FLASH-BACK”, you must clean the burner tubes before assembling your grill, and at least once a month in late summer or early fall when spiders are most active. Also perform this burner tube cleaning procedure if your grill has not been used for an extended period of time.

### **WHEN TO LOOK FOR SPIDERS**

You should inspect the burners at least once a year or immediately after any of the following conditions occur:

1. The smell of gas in conjunction with the burner flames appearing yellow.
2. The grill does not reach temperature.
3. The grill heats unevenly.
4. The burners make popping noises.

### **BEFORE CALLING FOR SERVICE**

If the grill does not function properly, use the following check list before contacting your dealer for service. You may save the cost of a service call.

## TROUBLE SHOOTING

**PREHEATING:** The grill lid should be in a closed position during the preheat time period. It is necessary to preheat the grill for a short time before cooking certain foods, depending on the type of food and the cooking temperature. Food that requires a high cooking temperature needs a pre-heat period of five minutes; food that requires a lower cooking temperature needs only a period of two to three minutes. There is no need to preheat for casseroles or other foods that require slow cooking.

### COOKING TEMPERATURES

**High setting-**Use this setting for fast warm-up, for searing steaks and chops, and for burning food residue from the cooking grids.

**Medium setting-**Use this setting for grilling, roasting or baking.

**Low setting-**Use this setting for all smoke cooking, and when cooking very lean cuts such as fish.

These temperatures vary with the outside temperature and the amount of wind.

**Cooking with in-direct Heat:** You can cook poultry and large cuts of meat slowly to perfection on one side of the grill by indirect heat from the burner on the other side. Heat from the lighted burner circulates gently throughout the grill, cooking the meat or poultry without any direct flame touching it. This method greatly reduces flare-ups when cooking extra fatty cuts, because there is no direct flame to light the fats and juices that drip down during cooking. Place a drip pan slightly smaller than the cut of meat on the flame tamer surface under the meat being cooked. This will allow you to catch meat juices for making gravy.

**Flare-Ups:** The fats and juices that drip from the meat cause flare-ups. Since flare-ups impart the distinctive taste and color for food cooked over an open flame, they should be expected and encouraged within reason.

Nevertheless, uncontrolled flaring can result in a ruined meal.

**CAUTION:** If burners go out during operation, close gas supply at source, and turn all gas valves off. Open lid and wait five minutes before attempting to re-light (this allows accumulated gas fumes to clear).

**CAUTION:** Should a grease fire occur, close gas supply at source, turn off all burners and leave lid closed until fire is out.

**CAUTION:** DO not attempt to disconnect any gas fitting while your barbecue is in operation. As with all appliances, proper care and maintenance will keep them in top operation condition and prolong their life. Your gas grill is no exception.

## TROUBLE SHOOTING

- Cover may be incorrect for your grill. It may be a tight fit. Ensure the cover correct length for your grill. Measure it left to right. Compare to the grill's measurement.
- Compare the location and size of the hood portion of the cover to your grill.
- Spread the cover and allow it to relax, preferably in warm sunlight or in a warm room.

PROBLEM	SOLUTION
When I light the grill it does not flame immediately .	<ul style="list-style-type: none"> <li>--Make sure you have turn on the gas</li> <li>--Make sure it has spark while you are trying to ignite the burner.</li> <li>--Push in for approximately 5 second before to turn and ignite the grill.</li> <li>--Make sure your burner is clean.</li> </ul>
Rotisseries burner will not light when the igniter button is pushed.	<ul style="list-style-type: none"> <li>--Check to see if debris is blocking the electrode sparks.</li> <li>--Check to see there is spark that jumps to the burner from the electrode wire. If no spark is seen.</li> <li>--Check the battery located inside the button. Press and turn counter clockwise.</li> <li>--Check for loose wire connection.</li> <li>--Gently bend the electrode wire closer to the burner until a spark is seen to jump from the igniter to the burner when you press the starter button.</li> <li>--Dose the infrared back burner light when attempting to match light? If not, check did you turn on the gas.</li> </ul>
Regulator makes noise.	<ul style="list-style-type: none"> <li>--Vent hose on the regulator may be plugged or regulator may be faulty.</li> <li>--Ensure the vent hole on the regulator is not obstructed. Clear the hole, close the gas control valves. Wait ten minutes and re-start.</li> <li>--Check your flames for proper performance if the flames are not correct replace regulator.</li> </ul>
Full size cover does not fit the grill.	<ul style="list-style-type: none"> <li>--Cover may be incorrect for your grill. It may be a tight fit. Ensure the cover correct length for your grill. Measure it left to right. Compare to the grill's measurement.</li> <li>--Compare the location and size of the hood portion of the cover to your grill.</li> <li>--Spread the cover and allow it to relax, preferably in warm sunlight or in a warm room.</li> <li>--For grill with a side shelf bunch the cover like a sock, put on left to right.</li> </ul>

## TROUBLE SHOOTING

<p>Rotisserie motor will not turn</p>	<ul style="list-style-type: none"> <li>--Check the voltage at the outlet.</li> <li>--If an extension cord is required, ensure it is a 16 gauges, grounded cord.</li> <li>--Ensure the on/off switch is on.</li> <li>--Ensure the load does not exceed the 40 pounds operational capacity.</li> <li>--Ensure the spit is fully inserted in the motor.</li> <li>--Ensure there is no encumbrance or drag.</li> </ul>
<p>Grill only heats to 200-300 degrees.</p>	<ul style="list-style-type: none"> <li>--Ensure the temperature gauge is functioning properly. Hold a flame to the probe or compare the grill gauge to an oven thermometer place in the grill.</li> <li>--Ensure correct start procedure. Prior to lighting grill, the gas control knobs should be off. The propane bottle should be off. If not, wait 15 minutes. Turn tank all the way on.. Turn left burner to ignite, wait 5 seconds ignite. Repeat for additional burners.</li> <li>--Check all gas connections for leaks with bubble test. If leaks are found, replace the part or tighten the fitting.</li> <li>--If it is a natural gas grill, ensure there is proper pressure to the grill. Refer to the user manual. Example: Gas line stubbed off o pool heater may exhibit deference in pressure.</li> </ul>
<p>Grill takes a long time to preheat.</p>	<ul style="list-style-type: none"> <li>--Normal preheat 500-600degrees, takes about 10-15 min. Cold weather and wind may effect your preheat time.</li> <li>--If you are using volcanic rock or briquettes they can increase the preheat time and maximum temperature.</li> </ul>
<p>Burner flames are not light blue.</p>	<ul style="list-style-type: none"> <li>--Too much or not enough air mixes for the flame.</li> <li>--Elevation is the principal cause, however cold weather can affect the mixture. Burner adjustment may be required.</li> <li>--Grill is in a windy location.</li> </ul>

# EXPLODED VIEW

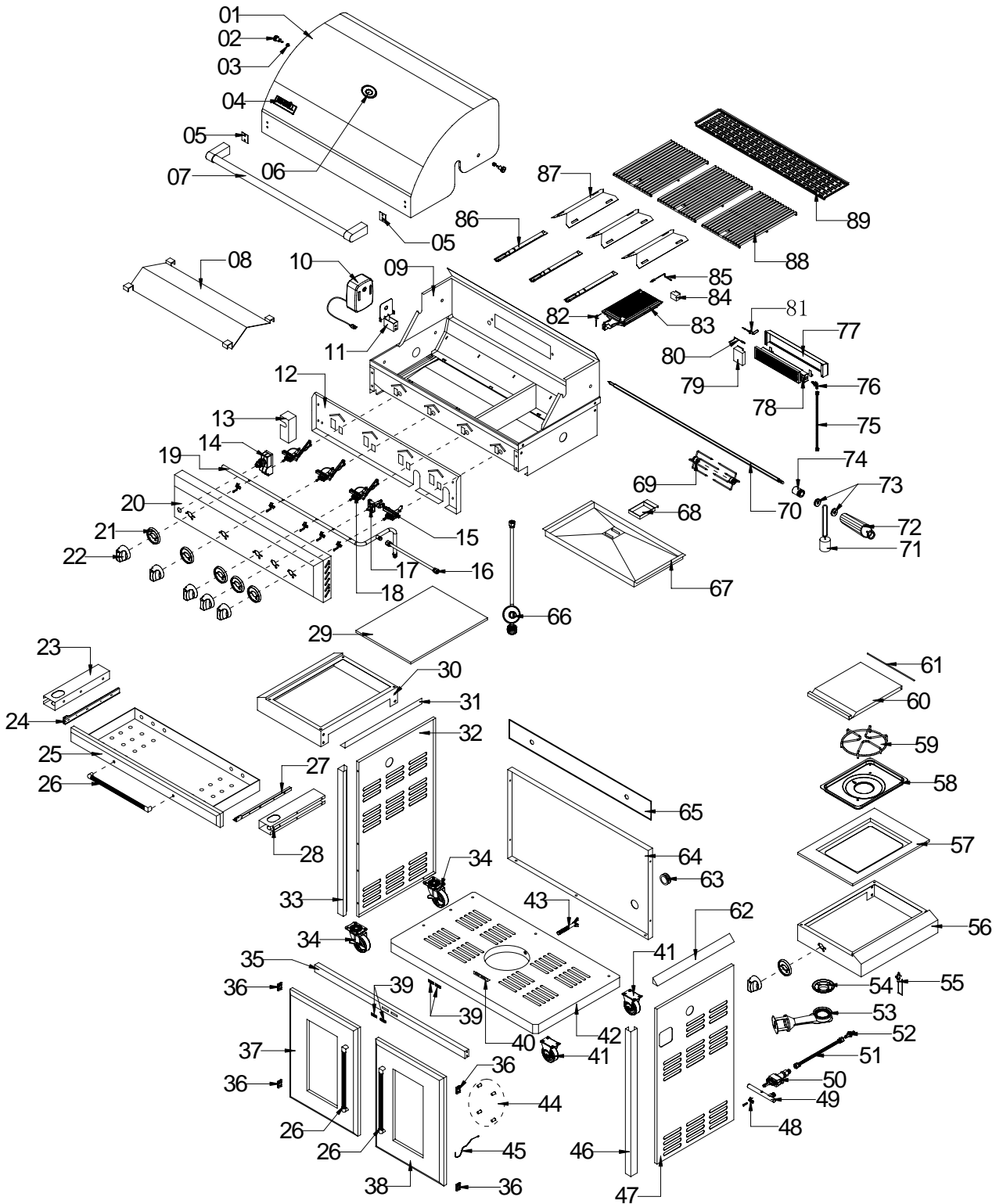

# PARTS LIST

REF#	DESCRIPTION	QTY	REF#	DESCRIPTION	QTY
1	Main Lid	1	27	Utility Drawer Slide, Right	1
2	Main Lid Screw	2	28	Utility Drawer Slide Bracket right	1
3	Main Lid screw cover	2	29	Side Shelf, Left B	1
4	Logo	1	30	Side Shelf, Left A	1
5	Main Lid Handle Heat Insulating Spacer	2	31	Side Shelf Trim Panel,Left	1
6	Temperature Gauge	1	32	Side Panel, Left	1
7	Main Lid Handle	1	33	Front Trim Panel, Left	1
8	Grease Slide Panel, Top	1	34	Swivel Caster with Brake	2
9	Main Burner Bowl Assembly	1	35	Cart Frame , Front	1
10	Rotisserie Motor	1	36	Door Hinge	4
11	Rotisserie Motor Bracket	1	37	Front Door, Left	1
12	Front Baffle	1	38	Front Door, Right	1
13	Pulse Igniter Module Cover	1	39	Door Magnet	4
14	Pulse Igniter Module	1	40	Door Magnet Bracket	1
15	Sear Gas Valve	1	41	Caster	2
16	Side Burner Hose	1	42	Bottom Panel, LP	1
17	Rotisserie Gas Valve	1	43	Tank Bolt	1
18	Main Gas Valve	3	44	Door handle Plastic Insert	1
19	Main Manifold	1	45	Lighting Rod	1
20	Main Control Panel	1	46	Front Trim Panel, Right	1
21	Bezel	6	47	Side Panel, Right	1
22	Control Knob	6	48	Manifold retainer bracket	6
23	Utility Drawer Slide Bracket left	2	49	Side Manifold	1
24	Utility Drawer Slide, Left	1	50	Side Gas Valve	1
25	Utility Drawer	1	51	Side Burner Flex Gas line	1
26	Door and Utility Drawer Handle	3	52	Side Burner Orifice Brass Connector	1

## PARTS LIST

REF#	DESCRIPTION	QTY	REF#	DESCRIPTION	QTY
53	Side Burner Pipe	1	72	Rotisserie Handle	1
54	Side Burner Ring	1	73	Key Washer	2
55	Side Burner Igniter wire	1	74	Shaft Collar	1
56	Side Burner bowl Assembly Frame A	1	75	Rotisserie Burner Flex Gas line	1
57	Side Burner Bowl Assembly Frame B	1	76	Rotisserie Orifice w/Brass Elbow	1
58	Side Burner Bowl Assembly Fire Box	1	77	Rear Baffle	1
59	Side Burner Cooking Grate	1	78	Rotisserie Burner	1
60	Side Burner Lid	1	79	Thermocouple Bracket (Rotisserie Burner)	1
61	Side Burner Lid Hinge Rod	1	80	Thermocouple (Rotisserie Burner)	1
62	Side shelf Trim Panel, Right	1	81	Rotisserie Burner Igniter Wire	1
63	Rubber Grommet	1	82	Sear Burner Igniter Wire	1
64	Back Panel	1	83	Sear Burner	1
65	Back Panel, Top	1	84	Thermocouple Bracket (Sear Burner)	1
66	Regulator, LP	1	85	Thermocouple (Sear Burner )	1
67	Grease Slide Panel, Bottom	1	86	Main Burner	3
68	Grease Tray	1	87	Flame Tamer	3
69	Spit Fork	2	88	Cooking Grid with Hole	3
70	Spit Rod	1	89	Warming Rack	1
71	Counter-Balance	1			



The doneness of meat, whether rare, medium, or well done, is affected to a large degree by the thickness of the cut. Expert chefs say it is impossible to have a rare doneness with a thin cut of meat.

The cooking time is affected by the kind of meat, the size and shape of the cut, the temperature of the meat when cooking begins, and the degree of doneness desired.

When defrosting meats it is recommended that it be done overnight in the refrigerator as opposed to a microwave. This in general yields a juicier cut of meat.

Use a spatula instead of tongs or a fork to turn the meat, as a spatula will not puncture the meat and let the juices run out.

To get the juiciest meats, add seasoning or salt after the cooking is finished on each side and turn the meat only once (juices are lost when the meat is turned several times). Turn the meat just after the juices begin to bubble to the surface.

Trim any excess fat from the meat before cooking. To prevent steaks or chops from curling during cooking, slit the fat around the edges at 2-inch intervals.

**DO NOT LEAVE THE GRILL  
UNATTENDED WHILE COOKING.**

# GRILL COOKING CHART

FOOD	WEIGHT OR THICKNESS	FLAME SIZE	APPROXIMATE TIME	SPECIAL INSTRUCTIONS AND TIPS
<b>VEGETABLES</b>				
Fresh				Slice.Dot with butter or margarine Wrap in heavy-duty foil.Grill,turning occasionally
Beets		Medium	12 to 20 minutes	
Carrots				
Turnips				Grill,turning once.Brush Occasionally With melted butter or margarine
Onion	1/2 inch slices	Medium	8 to 20 minutes	
Potatoes				Wrap individually in heavy-Duty foil.Grill,rotating Occasionally.
Sweet	Whole	Medium	40 to 60 minutes	
White	6 To 8 ounces	High	45 to 60 minutes	
Frozen				Dot with butter or margarine Wrap in heavy-duty foil.Grill Turning occasionally
Asparagus		Medium	15 to 30 minutes	
Broccoli				
Brussels				
Sprouts				
Green beans				
Peas				
French fries		Medium	15 to 30 minutes	Place in aluminum foil pan. Grill, stirring occasionally.
<b>MEATS</b>				
Beef				
Hamburgers	1/2 to 3/4inch	Medium	10 to 18 minutes	Grill,turning once when juices rise to the surface Do not leave hamburgers unattended since a flare-up could occur quickly
		High	8 to 15 minutes	
Steaks				
Rib eye,				

# GRILL COOKING CHART

FOOD	WEIGHT OR THICKNESS	FLAME SIZE	APPROXIMATE TIME	SPECIAL INSTRUCTIONS AND TIPS
FISH AND SEAFOOD				
Steaks				Grill, turning once. Brush with melted butter, margarine or oil To keep moist.
Halibut	3/4 to 1 inch	Medium to	8 to 15 minutes	
Salmon		High		
Swordfish				
Whole				
Catfish 4 to 8 ounces	4 to 8 ounces	Medium to	12 to 20 minutes	Grill turning once. Brush with Melted Butter, margarine or oil.
Rainbow trout		High		

## BBQ SALMON

2 large salmon steaks  
 2 tbs. Oil  
 Salt & pepper  
 2 oz. thin bacon slices  
 2 tbs. Butter  
 1 tbs. Lemon juice  
 Spring of parsley  
 Lemon wedges  
 Preheat the BBQ.

Brush the steaks with oil and season with salt and pepper. Place on BBQ grill and cook for 10 minutes, turning steaks over halfway cooking time.

Meanwhile fry the bacon in a pan on the side burner. Drain on paper towels. Meld the butter in a small saucepan taking care not to discolor it. Arrange the fish and bacon on serving plates. Pour the butter over and sprinkle with lemon juice. Garnish with parsley springs and lemon wedges. Serve with boiled potatoes tossed in butter and sprinkled with chopped parsley and a crisp lettuce salad.

- Note: Substitute catfish, halibut or cod for salmon.

## BAKED CHILI CORN

- 6 medium ears corn, husked
- 3 tbs. Butter or margarine, melted
- Dash ground cumin
- Dash ground coriander
- About ½ hour before cooking, turn the butter on for grill. Place each corn on a heavy-duty foil. In a bowl, combine remaining ingredients. Mix well. Brush 1-1/2 tsp. Butter mixture over each ear. Close foil and fold up ends to seal. Place on grill. Cook, turning packets occasionally 10 to 12 minutes or until cooked through.

## TANGY SEAFOOD KABOBS

1 lb. Large shrimp, shelled & deveined  
 ¾ lbs. sea scallops  
 2/3 c. chili sauce  
 ¼ c. cider vinegar  
 butter and sprinkled with chopped parsley and a crisp lettuce salad.

In medium bowl, combine shrimp and scallops. In small bowl combine chili sauce and next six ingredients. Pour over seafood. Toss to coat. Cover, refrigerate 2 hours.

Note: Substitute catfish, halibut or cod for salmon.

## PORK CHOPS

4 Pork chops  
 Marinade  
 1 large onion  
 2 tbs. lemon juice or vinegar  
 2 tbs. oil  
 ½ tsp. powdered mustard  
 2 tsp. Worcestershire sauce  
 ½ tsp. freshly ground black pepper  
 1 tsp. sugar  
 ½ tsp. paprika  
 1 clove garlic

Peel, grate onion, and add rest of the ingredients except the pork chops. Mix well. Pour over chops and marinate one hour in a cool place. Turn the BBQ grill on full. Heat 10 minutes. BBQ the chops brushing with the marinade occasionally. Serve with mixed salad, dressed with vinaigrette flavored with fresh dill.

3 tbs. chopped parsley  
 1 tbs. vegetable oil  
 1 tbs. Worcestershire sauce  
 ½ tsp. prepared horseradish  
 1 cove garlic, minced  
 1 20 oz. Can pineapple chunks in juice, drained

Half hour before cooking, turn the burner to the grill on full. Drain seafood reserving marinade. On each of twelve 10" skewers, thread 2 shrimps and 2 scallops, alternating with pineapple chunks. Place skewers on grill. Cook 7-10 minutes, often basting and turning.

## BARBECUED LONDON BROIL

4 to 6 servings  
 ¾ c. Italian dressing  
 1 tsp. Worcestershire sauce  
 1 tsp. dry mustard  
 ¼ tsp. thyme, crushed  
 1 medium onion, sliced  
 1 pound flank steak, scored  
 2 tbs. butter, melted

Combine first 4 ingredients, add onion and marinade flank steak with it. Refrigerate at least 4 hours or overnight. Remove steak and grill on your preheated BBQ grill. Grill 5 to 7 minutes on each side basting frequently with the marinade. In the meantime sauté onions from the marinade in butter in a skillet on your side burner for 3 minutes. To serve, slice steak diagonally into thin slices, sprinkle onions over top. Garnish with vegetable kabobs.

## BARBECUED POTATOES and CHEESE

1-1/2 cups shredded cheddar cheese  
 1 can (10-3/4 oz.) condensed cream of mushroom soup  
 1/3 cup milk  
 2 tbs. barbecue sauce  
 ¼ tsp. oregano  
 ¼ tsp. salt  
 1/8 tsp. pepper  
 4 cups thinly sliced potatoes (4 medium-sized potatoes)

## GRILL RECIPE SUGGESTIONS

Preheat grill. Combine cheese, condensed soup, milk, BBQ sauce, oregano, salt and pepper in a large mixing bowl. Stir in potatoes until well coated. Turn into well buttered 1-1/2 quart rectangular baking dish. Cover dish with aluminum foil. Bake covered 25 minutes on medium with the lid of your BBQ grill closed. Remove foil and continue baking 15 minutes longer or until potatoes are tender. Let stand 5 minutes before serving.

### VEGETABLE KABOBS

3 medium-sized zucchini  
12 cherry tomatoes  
12 fresh mushrooms  
Grated Parmesan cheese

Parboil whole zucchini 5 minutes on your side burner or until just tender. Drain and cut into 1/2 inch slices. Thread zucchini, tomatoes and mushrooms alternately on each of six skewers. Brush with marinade made of Italian dressing, Worcestershire sauce, mustard and thyme. Grill 5 to 7 minutes turning and basting occasionally. Sprinkle liberally with Parmesan cheese.

### FAJITAS

1-1/2 lb. flank steak or boned chicken breasts  
2 tbs. oil  
1/2 cup lime juice  
1/2 tsp. salt  
1/2 tsp. celery salt  
1/4 tsp. garlic powder  
1/2 tsp. pepper  
1/4 tsp. oregano  
1/4 tsp. cumin  
Flour tortillas lemon

Pound flank steak to 1/4 inch thickness or flatten chicken breasts. Mix oil, lime juice and seasonings in a zip lock bag. Add meat and shake bag to coat the meat. Refrigerate overnight or at least 6 to 8 hours. Wrap tortillas in foil. Remove meat from marinade. Cook on a pre-heated gas grill for 5 to 8 minutes on each side. While meat is cooking, heat tortillas on grill. Slice meat across grain in thin slices. Place on hot platter. Squeeze lemon juice over. Wrap meat and any of the following toppings in tortillas: chopped tomatoes, guacamole, sour cream, taco sauce.

### BEEF AND LAMB KABOBS

Serve 4

1/2 lb. boneless sirloin or beef cut into 1" cubes  
1/2 lb. boneless loin of lamb cut into 1" cubes  
2/3 c. water, divided  
1/4 c. chopped onion  
2 tbs. soy sauce  
1/4 c. vegetable oil, divided  
1 tbs. dark brown sugar  
1 tbs. fresh lemon juice  
2 cloves garlic, minced  
1/4 tsp. ground cumin  
1/4 tsp. ground coriander  
1/4 tsp. ground turmeric  
1/8 tsp. ground red pepper  
1/8 tsp. ground ginger  
1 red pepper cut into chunks  
1 large banana, cut into chunks  
8 small mushrooms  
1/3 c. smooth peanut butter

In blender, process 1/3 c. water, onion, soy sauce, 2 tsp. oil and the next 8 ingredients until smooth. Pour over meat cubes and marinate about 4 hours, turning occasionally. Drain and reserve marinade. Onto to four 12" skewers alternately thread meat, pepper, banana and mushrooms. Preheat grill. Brush the kabobs with oil. Grill 7-8 minutes each side.

Bring marinade to boil on the side burner in a saucepan. Add remaining 1/3 c. water and peanut butter. Stir to blend. Heat through. If sauce gets too thick, add 1 tbs. water. Serve sauce with kabobs.

### EGGPLANT CAVIAR

1 large eggplant  
2 tbs. olive oil  
2 tbs. wine vinegar  
2 tbs. finely chopped onion  
1/2 clove garlic, minced  
1 medium tomato, chopped salt and pepper

Roast eggplant on gas grill over medium flame, turning occasionally until thoroughly cooked. This may take 30 minutes. Remove from grill and cool for handling. Strip off the skin and chop eggplant finely. Add all the seasonings. Chill thoroughly and serve on toast.

## GRILL RECIPE SUGGESTIONS

### CHICKEN TANDOORI STYLE

8 large chicken thighs or drumsticks

1 c. plain nonfat yogurt

½ c. lemon juice

2 tsp. salt

½ tsp. cayenne

½ tsp. black pepper

½ tsp. crushed garlic

½ tsp. grated ginger

1 tbs. corn oil

Combine all the ingredients in a large mixing bowl and marinate the chicken for 8 hours in the refrigerator. Drain the chicken and spread on the spit running the rod on the fleshier side of the bone.

Rotis using the rotisserie burner. Cook on medium high heat for 40 minutes basting occasionally with the remainder of the marinade mixture. Serve with sliced onions and lemon wedges.

### SPARE RIBS

Marinade:

1 c. soy sauce

½ c. honey

½ c. vinegar

½ c. dry sherry

2 tsp. chopped garlic

2 tsp. sugar

1 c. water

1 chicken bouillon cube

1 can beer for basting sauce

Marinate ribs for 3 hours. Use marinade for basting by adding beer to it. Place pan under the ribs and baste frequently. To cook ribs select lean, meaty ribs and accordion pleat them with your spit. Slide four prong meat hook down the length of spit and tighten. At the beginning of

the rack and to its center, penetrate the second rib with the pointed end of the spit and push it between the meat. Skip a couple and continue the process until the entire rack is accordion pleated. Fasten the second meat hook into the rack. Turn your rotisserie burner on high. Rotis for 50 minutes or until done.

### PORK ROAST

Apple cider vinegar basting sauce:

1 c. apple cider vinegar

6 oz. water

½ stick butter

Salt, pepper, parsley and garlic seasoning

2 oz. lemon juice

10 lbs. pork roast

Time: 1-1/2 hours to 2 hours

Bring pork to room temperature before placing it on the spit rod. Place on the rod and test for balance. Light rotis burner. Turn control knob to high. Use the above basting sauce for rotissing.

### TURKEY

12 lb. turkey

Beer basting sauce:

1 can beer

12 oz. water

1 stick butter

1 tsp. salt

1 tsp. pepper

½ tsp. garlic flakes

1 tsp. parsley

Thaw the bird completely. Wash inside out. Securely tie the legs and wings. Light rotisserie burner. Turn to high. Combine all the ingredients for basting sauce in a shallow pan. Place it under the turkey 15 to 20 minutes. Cook for approximately 3 hours. The basting sauce combined with turkey drippings makes a delicious gravy.

# LIMITED WARRANTY

## LIMITED WARRANTY

### MODEL 730-0439

### STAINLESS STEEL OUTDOOR GAS GRILL

Nexgrill Industries, Inc. warrants to the original consumer purchaser of each Outdoor Gas Grill that when subject to normal residential use, it is free from defects in workmanship and materials for the periods specified below. This warranty excludes grills used in rental or commercial applications. There will be a shipping and handling charge for the delivery of the warranty part(s).

<u>Component</u>	<u>Warranty Period</u>
Grill Rods:	3 Years
Cart Frame:	3 Years
Grill Lid:	3 Years
Control Panel Housing:	3 Years
Side Shelves :	3 Years
Stainless Steel Burners:	5 Years
Rear Burner:	3 Years
Valves and Knobs:	1 Year
Ignition System:	1 Year
Gas Supply System:	1 Year
Casters:	1 Year
Temperature Gauge	1 Year
PVC Cover	1 Year

Our obligation under this warranty is limited to repair or replacement, at our option, of the product during the warranty period. The extent of any liability of Nexgrill Industries, Inc. under this warranty is limited to repair or replacement. This warranty does not cover normal wear of parts, damage resulting from any of the following: negligent use or misuse of the product, use on improper fuel/gas supply, use contrary to operating instructions, or alteration by any person other than our factory service center. The warranty period is not extended by such repair or replacement.

Warranty claim procedure: If you require service or parts for your grill, please contact our Warranty Service Center for factory direct assistance. Our hours of operation are 8 AM to 5 PM PST. Our number is 1-800-984-7455 and our FAX number is 1-800-598-8829. Please direct all correspondence to: Warranty Service Center.

Product repair as provided under this warranty is your exclusive remedy. Nexgrill Industries, Inc. shall not be liable for any incidental or consequential damages for breach of any express or implied warranty on its products. Except to the extent prohibited by applicable law, any implied warranty or merchantability or fitness for a particular purpose on this product to the duration of the above warranty. Some states do not allow the exclusion or limitation of incidental or consequential damages, or allow limitations on how long an implied warranty lasts, so the above limitations or exclusions may not apply to you. This warranty gives you specific legal rights, and you may have other rights, which vary from state to state.

Manufactured by: **Nexgrill Industries, Inc. 280 Machlin Court, City of Industry, CA 91789**

Please register your product online at:

**www.NEXGRILL.com**

*(If you register online, you do not need to send in this registration card.)*

**Please fill out this card and return it within 10 days of purchase to accommodate customer and service inquiries to the manufacturer. Failure to return the card may delay response time and/or complicate response to customer inquiries. Remember to keep your sales receipt. The warranty is non-transferable. Customers should include a copy of their original sales receipt as proof of purchase. The receipt should be mailed along with the registration card; or mailed after the online registration is completed, along with a printed confirmation.**

Llene por favor esta tarjeta y lo vuelve dentro de 10 días de la compra a acomodar las indagaciones de cliente y servicio al fabricante. El fracaso para volver la tarjeta puede demorar el tiempo de respuesta y/o complicar la respuesta a indagaciones de cliente. Recuerde de mantener su recibo de ventas. La garantía es intransferible. Los clientes deben incluir una copia de su recibo original de ventas como comprobante de compra. El recibo debe ser enviado junto con la tarjeta de matrícula; o enviado después de que la matrícula en el internet sea competida, junto con una confirmación impresa.

Veuillez remplir cette carte et la renvoyer dans les dix jours après votre achat à l'attention du service clientèle et réclamations du fabricant. Ne pas renvoyer la carte pourrait retarder ou compliquer la procédure lors de toute réclamation. N'oubliez pas de garder votre ticket de caisse lors de l'achat. La garantie est non transférable. Le client doit joindre une copie de son ticket de caisse original comme preuve d'achat. Le ticket doit être renvoyé avec la carte de garantie; ou après l'enregistrement complété en ligne sur internet, de pair avec une copie imprimée de la confirmation.

**1** First Name/Nombre/Prénom Initial/Inicial/Initiale Last Name/Apellido/Nom de famille

\_\_\_\_\_

Address (number and street)/Dirección (número y calle)/Adresse (numéro et rue) Apt Number/Nº de apart./Nº d'apprt.

\_\_\_\_\_

City/Ciudad/Ville State/Estado/Province Zip Code/Código zip/Code postal

\_\_\_\_\_

**2** E-mail Address/Dirección de correo electrónico/Adresse électronique  
*If you voluntarily provide us with your email address, you give us permission to use your email address to send you offers that may interest you. Si nos informa voluntariamente su dirección de correo electrónico, nos da permiso para usarlo a fin de enviarle ofertas que pueden interesarle. Si vous choisissez de nous fournir votre adresse électronique, vous nous donnez la permission de l'utiliser pour vous faire part d'offres spéciales susceptibles de vous intéresser.*

\_\_\_\_\_

*(Example: your name@your host.com) (Ejemplo: su nombre@su host.com) (Exemple: votre nom@votre hôte.com)*

**3** Phone Number/Número telefónico/Numéro de téléphone

\_\_\_\_\_

**4** **IMPORTANT! ¡IMPORTANTE! IMPORTANT!**  
*Write Serial Number and Model Number in spaces below. Escribe en los espacios de abajo el número de serie y el número de modelo. Inscrivez le numéro de série et le numéro de modèle dans les espaces ci-dessous.*

**5** Date of Purchase/Fecha de compra/Date de l'achat

\_\_\_\_\_

**6** Store Name/Nombre de la tienda/Nom du magasin

\_\_\_\_\_

**7** Purchase Price/Precio de compra/Prix d'achat  
\$ \_\_\_\_\_ .00

\_\_\_\_\_

**Mail to:/Envíelo a:**

Warranty Registration Department  
280 Machlin Ct  
City of Industry, CA 91789