

Installation Instructions & Owner's Manual



This symbol on the product means the product is listed by Underwriters Laboratories, Inc.



ELECTRONIC STEAM UNIT - POWER HUMIDIFIER MODELS S2000 AND S2020

FOR GAS OR OIL FORCED AIR FURNACES, HEAT PUMPS AND ELECTRIC FURNACES

The AutoFlo Residential Power Humidifier you have purchased has been designed to be simple to Install, Operate and Maintain. Read this manual before you install the Humidifier.

Familiarizing yourself with the items listed in Figures 1 and 2 will assist you in installing and maintaining your Steam Power Humidifier.

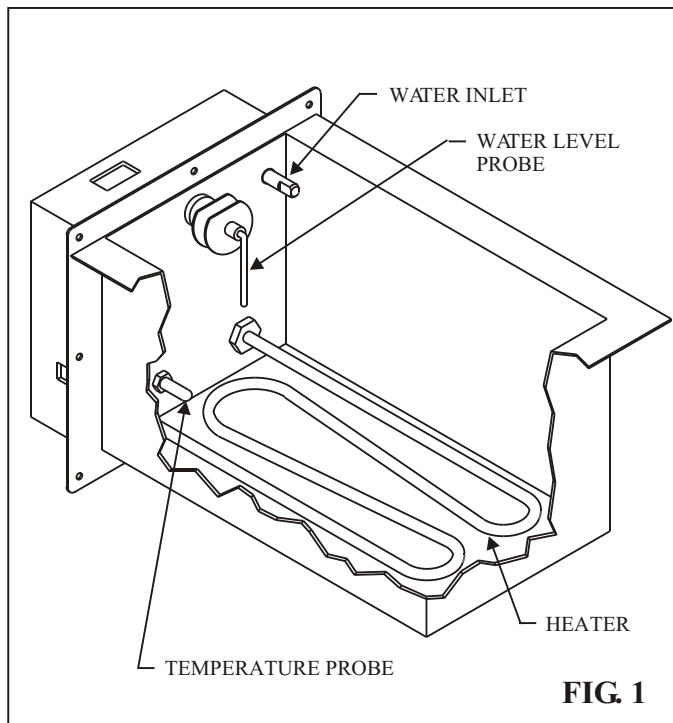

FIG. 1

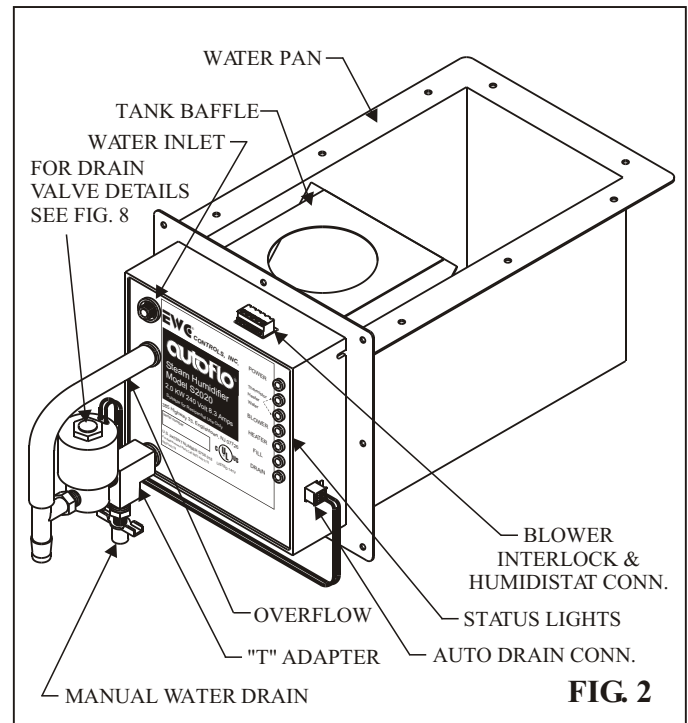

FIG. 2

Parts included in the Steam Humidifier package are:

1. Self Piercing Saddle Valve
2. Installation Instructions and Owners Manual
3. Mounting Templates x2
4. Installation Hardware package
5. Insulation and tape
6. Automatic Drain Assembly
7. Humidistat - Autoflo Models 062000 or 072000
8. 1/2" I.D. Drain Hose-8 FT.
9. Anode #Z 100

Options and additional parts recommended:

1. Water Hammer Arrester #WH 100
2. Anode #Z 100
3. Decorative under duct cover # Sc100
4. Gasket Material to seal flanges (field provided)

SIMPLIFIED INSTALLATION INSTRUCTIONS

1. Insulate the water reservoir. See figure 3.
2. Select the mounting location on the duct and tape on the mounting template.
3. Drill the (8) 1/8" mountings holes.
4. Cut out the humidifier opening in the duct.
5. Insert the humidifier into the opening and screw in place.
6. Connect the water line.
7. Connect the drain line.
8. Make 24 VAC electrical connections to blower interlock.
9. Install and connect the humidistat.
10. Plug power cord into a grounded dedicated 120 VAC, 15 amp outlet for S2000 (240 VAC, 10 amp for S2020).

If the humidifier installation does not meet the required criteria, consider using a different Autoflo model humidifier such as a SC15 or 200P.

DETAILED INSTALLATION INSTRUCTIONS

1. INSULATE WATER TANK RESERVOIR

With insulation foil side down, remove adhesive backing. Align humidifier so that front side of unit meets long edge of insulation. Fold insulation up onto sides of humidifier and press firmly. Apply 5 continuous strips from the tape provided to seal the foil as shown. The tape will prevent the sharp duct edges from damaging the foil. Use additional foil tape to repair damage to the foil. The Insulation **MUST** be applied to the tank regardless of the mounting location.

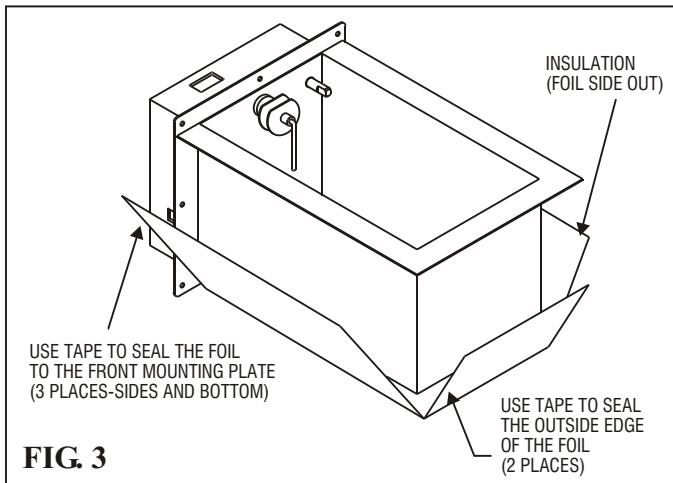

FIG. 3

2. LOCATION-LOCATION - Required Criteria

DO NOT INSTALL this unit in an attic unless freeze and flood protection measures are taken! See page 12 for details. The steam humidifier can be installed in either the warm air supply or the cold air return ducts; however the **preferred** location would be in the warm air supply duct of the heating system. This humidifier does not require warm air to evaporate the water in order to provide humidity, but it will operate more efficiently in the warm air duct and condensation is less likely to occur on the surrounding cold surfaces. Efficiency is lost in a return air duct location.

When selecting a location on the duct, be certain that there is enough room in the duct for the water reservoir. There should be at least five (5) inches above the reservoir and the reservoir should not occupy more than about 25 percent of the duct space. If this criteria can not be met, you should install the unit under the duct by means of the tank flange. A template is provided for installing the unit under the duct, on the cold air return.

A suitable means of gravity draining the unit should be available, Although the unit will work with the drain valve physically or electrically disconnected. See page 12.

3. WEIGHT - Required Criteria

If the humidifier is installed on fiberglass duct, the installer must provide structural support for the unit.

The fiberglass duct alone will not support the weight of the steam humidifier, which is 9 Lbs. empty and 15 Lbs. when full of water. Providing Adequate Structural Support for this unit is the responsibility of the Installer

4. MOUNTING TEMPLATE

Two mounting templates are provided. Choose the correct template for your mounting method. Tape the mounting template to the duct. The template must be leveled using the top of the cutout on the template. The template should be located so that the bottom of the reservoir cut-out is flush with the inside of the bottom of the duct for horizontal duct. Since most ducts are insulated this additional space, about one (1) inch, must be accounted for when determining the location for the bottom of the reservoir cut-out. If you are mounting it under the duct, make sure the duct is level.

5. DRILL HOLES AND CUT OPENINGS

Use an electric drill, with grounded power cord, to drill eight (8) mounting holes, 1/8" diameter, in the duct. These can be drilled through the template at the locations indicated on the template.

A saber saw or tin snips can be used to cut out the water reservoir opening.

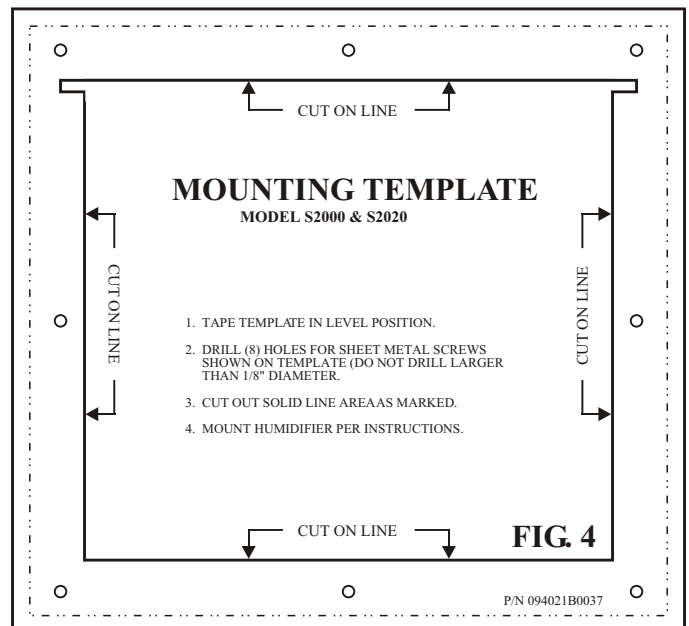

FIG. 4
P/N 094021B0037

6. WATER SUPPLY - Required Criteria

A. WATER SUPPLY USING THE SADDLE VALVE FURNISHED WITH UNIT

Installation instructions for the saddle valve are printed on the plastic bag containing the saddle valve and its components. Tap into a 1/2" or 3/4" domestic hot water line for best results, but a cold water line will do. Avoid connecting to water lines from a Reverse Osmosis system. **The supply water must read a minimum of 25 ppm in order for the Steam unit to reliably sense the water.**

NOTE: Never install the saddle valve on the bottom of the water pipe. Sediment in the water pipe may clog the saddle valve. *When tightening the hex compression nut, tighten only enough to assure there are no leaks.*

NOTE: Saddle valves do not meet plumbing codes in some areas. A "T" fitting with a valve may be required to meet code or, if low water pressure causes frequent water alerts on the steam humidifier.

NOTE: Do not use any line which is served by a water softener. If your home has a water softener, make the water connections to a water line upstream from the water softener. A water softener is not a demineralizer. It merely exchanges various hard ions for soft ions in the water. These soft ions, or minerals, will build up in the humidifier, causing the need for frequent servicing. The evaporation of softened water may also produce a white powder which may be carried into the duct system and, ultimately, into your home.

Note: Use a water hammer arrester (WH-100) if water spikes occur during operation.

B. OVERFLOW & DRAIN LINES - Required Criteria

The use of an overflow line and drain line is always required.

Use the supplied 1/2" ID high temperature hose. Slip the hose over the 1/2" OD "T" drain fitting and use a hose clamp to secure. **Route the hose to a suitable drain, avoiding kinks, traps and sharp objects.**

DO NOT route the hose above the humidifier.

NOTE: Previous models required two [2] drain hoses. The new models include an integrated overflow tube with a high temperature barbed "T" fitting. The new design simplifies the installation process.

Failure to install all necessary drain lines will result in water leaks during normal operating conditions, and voids all warranties.

7. MOUNTING THE STEAM HUMIDIFIER

Use gaskets to seal where the steam flanges contacts the ductwork. Place the humidifier reservoir into the opening in the duct and secure with eight (8) sheet metal screws.

NOTE: If the ductwork will not support the unit in a level position with the water pan full of water, the duct-work must be reinforced. Both steam models weigh approximately 9 Lbs. empty and approximately 15 Lbs. full of water.

8. STEAM OPERATION

Because of the high output of this Humidifier, it must not be operated in ducts or plenums without the blower operating. The steam humidifier is designed to be "Dominant" over the Heating-Air Conditioning System Blower. The "System" Blower will be operated by the humidifier, when humidity is required to meet the demand. A minimum of 800 cfm is required for proper operation of the steam humidifier. Lower velocities will result in excessive condensation inside the duct.

A temperature sensor is mounted in the water reservoir of the humidifier. As the water temperature increases to about 170 degrees F, the computer closes a set of blower relay contacts. When the water cools to about 140 degrees F, the computer will open the relay contacts.

9. WIRING THE STEAM HUMIDIFIER

IMPORTANT: Dedicated fused circuits of the proper voltage and current ratings must be provided. All wiring must conform to local and national codes.

A. INSTALLING AND WIRING THE HUMIDISTAT

A humidistat, such as the AutoFlo Models 062000 or 072000 is required to control the Steam Humidifier. The humidistat may be installed on the wall in the living space or on the return air duct. **NOTE: *Continuous fan operation should be initiated if the humidistat is installed on the return air duct!*** Instructions for installation are packaged with the humidistat.

DO NOT connect any foreign voltage to the "H" terminals of the humidifier. The unit supplies it's own 24 volt control voltage. Simply connect the two "H" terminals straight to the humidistat terminals.

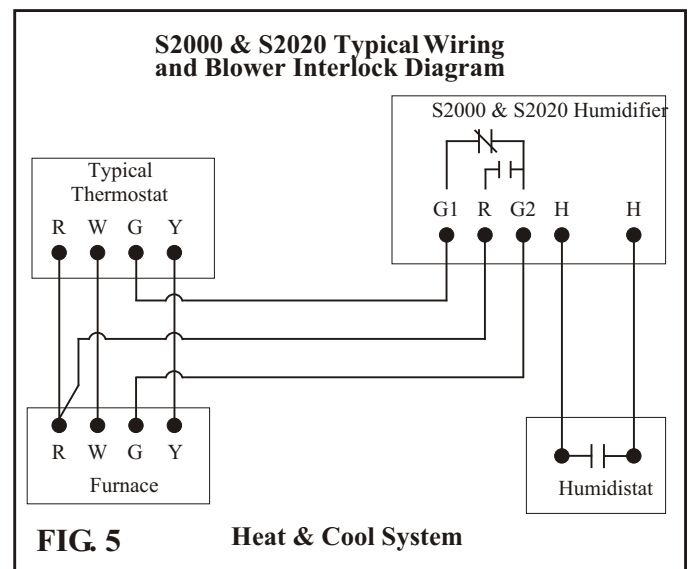

B. FIELD WIRING

All wiring must be made in accordance with local codes and ordinances. DO NOT cut off the grounded plug and/or hard wire this unit to line voltage. Do not use extension cords to operate this unit!

Figures 5 & 6 describes the suggested interlock wiring arrangement for HVAC systems. Interlocking may be performed on heating systems that provide a 24 VAC NEC Class 2 terminal for blower control.

IMPORTANT NOTE:

If the Steam Humidifier is removed and disconnected from the system, the blower interlock circuit must be restored to it's original configuration. Failure to do so may result in loss of blower operation!

10. SETTING THE HUMIDISTAT

It is recommended that humidistat settings of 30-40% not be exceeded. If condensation is noticed on windows during very cold outside temperatures, the humidistat setting should be lowered.

The maximum recommended relative humidity for your home depends upon factors such as outdoor air temperature, type and placement of insulation, vapor barriers, effectiveness of weather stripping, type of windows and doors (including frames and jambs) and whether or not storm windows and doors are used. With all these variables it is nearly impossible to recommend a proper humidity setting. The best humidistat setting is one that you are comfortable with. Also, as the outdoor temperature fluctuates, it may be necessary to adjust the humidity level of your system a few times during the heating season.

Refer to the "Relative Humidity Chart" as a starting point for your proper humidistat setting. Generally, in a tighter and better insulated house, the humidistat may be set higher than in a drafty, un-insulated house.

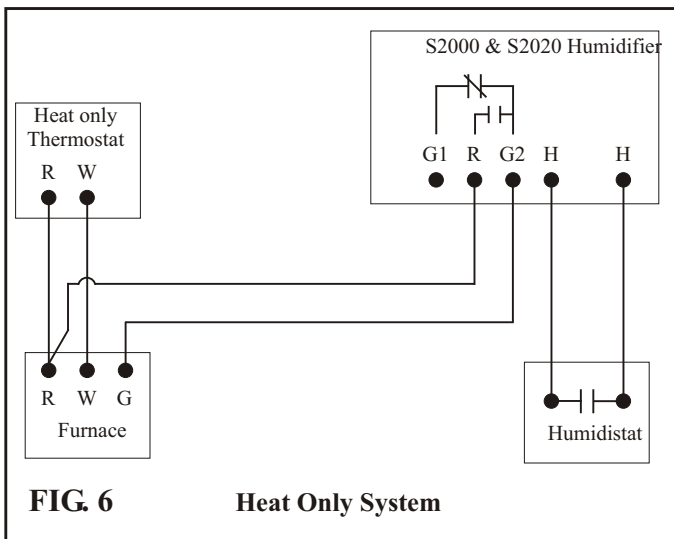

FIG. 6 Heat Only System

Connect field wiring as shown in Figures 5 or 6.

IMPORTANT: If the humidifier is installed in the return air plenum the humidistat must be located at least three (3) feet upstream from the humidifier. Fan should be operated in continuous mode when humidistat is mounted in the return air plenum.

The humidistat has two (2) screw terminals which should be connected to the low-voltage interlock plug. (Figure 5).

Wiring instructions for the 072000 model Humidistat are packaged with the 072000.

RELATIVE HUMIDITY CHART

Outside Temperature	Outside Relative Humidity	Indoor Relative Humidity When Outside Air Is Heated To 72 Degrees F	Maximum Safe Recommended Indoor Relative Humidity
-10 Deg. F	40%	1%	20%
	60%	2%	
	80%	2%	
0 Deg. F	40%	2%	25%
	60%	2%	
	80%	5%	
10 Deg. F	40%	4%	30%
	60%	5%	
	80%	7%	
20 Deg. F	40%	6%	35%
	60%	8%	
	80%	11%	
30 Deg. F	40%	8%	40%
	60%	13%	
	80%	17%	

11. INITIAL START-UP - SEQUENCE OF OPERATION and SERVICE "LED" INDICATORS

Once the Steam Humidifier has been installed and the water, humidistat and blower interlock connections completed, the humidifier may be initially started.

A. Flush and Turn "ON" the water supply to the steam Humidifier.

B. Set the humidistat to a high or "ON" position.

C. Plug the S2000 Humidifier line cord into a 120 VAC, 15 amp source. (240VAC, 10amp for S2020).

D. The Green "POWER" LED should blink rapidly and the drain valve will open momentarily upon initial start up. The "FILL" LED will illuminate and water should begin to fill the Water Pan.

E. When the water has reached the probe level the "FILL" lamp and fill valve will be turned off, and the "HEATER" LED and heater element will be turned on. The "POWER" LED will blink slow and steady.

F. Once the water reaches 170 deg. F. the "BLOWER" LED will illuminate and the system blower should start up.

G. If the above steps have been successfully completed, the humidifier is operating properly.

D. **BLOWER:** When the water in the reservoir reaches approximately 170 deg. F. the "BLOWER" LED will be illuminated and the interlock wiring should turn the system blower on. Depending upon the water and ambient temperatures, it may take anywhere from four to twelve minutes for the water to heat to 170 deg. F. If the humidistat remains closed the "HEATER" and "BLOWER" LED's will both be illuminated at the same time and the "POWER" LED will be blinking slowly.

E. The "FILL" LED will illuminate and the water reservoir will refill at irregular intervals, depending on the boil off rate. Depending upon the water temperature, the "BLOWER" LED may remain illuminated or may go off when the reservoir is filling. The "HEATER" LED should remain illuminated unless the humidistat opens or the humidifier enters a drain cycle or failure mode.

F. **DRAIN:** This LED will be illuminated when the microprocessor cycles the humidifier into a Maintenance Mode. *After a fan forced cool down period, the water is allowed to drain at 140 degrees F.* The drain valve will then close and the fill valve will open to refill the reservoir and resume normal operation. This mode will last about one hour and the microprocessor will automatically restart the unit afterwards, if there is a call for humidity. This drain cycle will occur once every 8-12 hours, to reduce the mineral concentration in the tank and let the heater cool-down. That will shed most deposits that have built up on the heater. NOTE: The "POWER" LED will blink rapidly during Maintenance mode.

NOTE: *A unique feature of the "S" series humidifiers is called "Fill on Request". The unit will not refill with water after a maintenance cycle, unless there is a demand for humidity from the humidistat. This ensures that the unit will not sit idle with standing water, which can stagnate over time.*

G. **FAILURE LED'S:** When service is required, these LED's will illuminate. If the humidifier enters a failure mode, it must be manually reset by disconnecting the power and then reconnecting it.

WATER: This will occur when the reservoir is not filling up with water, not filling fast enough or the microprocessor cannot recognize that the water is touching the probe. Reverse Osmosis water or purified (distilled/deionized) water sources should be avoided, unless the final feed water measures at least 25 ppm conductivity.

HEATER: This will occur if the humidifier is not boiling off water during the "HEATER" cycle. Water in the reservoir is not reaching 170 deg. F. temperature, or the unit has not detected a request for water in a 45 minute steaming time period. Both red LED's will illuminate in this condition.

THERMISTOR: This will occur if a short or open is detected in the temperature probe.

12. OPERATING SEQUENCE

A. **POWER:** In normal standby mode, when the humidistat is not calling for humidity and the power cord is plugged in, the "POWER" LED should be blinking slowly. If the green "POWER" LED is not flashing, when there is power to the unit, there has been a malfunction in the microprocessor circuit.

B. **FILL:** When the humidistat closes, on a call for humidity, the "FILL" LED is illuminated, the Solenoid Valve is open and the water reservoir is filling.

C. **HEATER:** When the water reaches it's proper level the valve closes, the "FILL" LED goes out, the "HEATER" LED is illuminated, and the Heater begins to heat the water.

NOTE: *If the humidifier is unplugged while in operation and then plugged back in, A rapid flashing of the "POWER" LED will occur and all other functions will stop! The unit wants to perform a water probe test, but cannot perform this test until the water cools down. Simply wait until the unit cools down and it will resume normal operations.*

13. MAINTENANCE/SPRING SHUTDOWN

Proper maintenance and removal of mineral deposits is still required on your steam humidifier in order to optimize performance. Annual cleaning is a must and more frequent cleaning may be necessary depending on the mineral content of the water in your area.

A post winter cleaning and shutdown, will prevent hard deposits from accumulating inside the bin, while the humidifier is idle over the summer. Do not allow the unit to sit idle for long periods without a proper draining, cleaning, and shutdown. Failure to do so, will affect the performance of your steam humidifier.

Maintenance and inspection of the unit requires removal of the humidifier from the duct. This can be done following these steps.

- A. Unplug the power cord from the 120 volt source for S2000 (240 volt for S2020) and allow the water to cool for at least 30 minutes prior to removal.
- B. Turn off the water supply at the saddle tapping valve.
- C. Remove the cable assembly wire plug from the top of the plastic control housing.
- D. Drain the water with the manual drain valve. NOTE: The drain valve will be hot if the humidifier has not been allowed to cool.
- E. Disconnect the water and drain lines. NOTE: Some water may drain out of the water line. Have a small container ready to catch the water.

NOTE: Although the water has been drained, some water may still remain in the humidifier reservoir along with sediment. Be careful not to tip the unit over when removing it from the duct.

Remove the eight (8) screws from the front mounting plate.

- F. Slide the humidifier out of the duct.
- G. Remove the two (2) screws holding the tank baffle to the pan flange and remove the baffle from the unit. Scrape all mineral deposits from the baffle and wash baffle off as described in step J. Remove the Anode from the baffle plate and purchase a new one. Operating the unit without the Anode will degrade the performance and increase maintenance.
- H. Use a putty knife to scrape the minerals from the sides and bottom of the water reservoir. DO NOT scrape on the small temperature probe, or the heater element. Use a soft emory cloth or brass brush.
- I. Carefully scrape the Water Level Probe to remove mineral deposits. Use soft emory cloth if necessary.
- J. Clean the Water Probe Insulator, inside the pan, with a cloth and 50-50 mixture of water and vinegar, rinse with fresh water. Inspect for any mineral deposits on the plastic insulator. Repeat cleaning if necessary and thoroughly dry. Use a small brass brush to clean deposits off the heater element and thermistor probe. Be careful not to damage any of the components.

- K. Rinse out the reservoir. Be careful to keep water off of the wiring compartment or the outside of the humidifier. **Allow the unit to dry thoroughly before using!**
- L. Reinstall the tank baffle and tighten the two (2) screws.
- M. Re-install the unit in the duct and connect the water line, the drain lines and the cable plug. Store the unit in this condition for the summer, or continue to the next step.
- N. Turn on the water supply. Inspect the water connections and drain fittings for leaks.
- O. Plug-in the S2000 power cord to the 120 VAC (240 VAC for S2020) grounded outlet. DO NOT use an extension cord.
 - a. The green POWER light should blink slowly.
 - b. If the humidistat is calling for humidity the water valve will energize and the water pan will begin to fill.

14. SERVICE INDICATORS

Seven LED lamps provided on the front panel indicate the functional status of the humidifier as shown in Figure 7 below.

LED LIGHT EXPLANATION

POWER	- GREEN - BLINKING SLOWLY-IF POWER TO UNIT
SERVICE THERMISTOR	- RED - ON STEADY
SERVICE HEATER	- RED - ON STEADY BOTH LED'S
SERVICE WATER	- RED - ON STEADY
BLOWER	- AMBER - ON STEADY WHILE PAN ABOVE 170 DEG F.
HEATER	- AMBER - ON STEADY WHILE HEATING (BOILING)
FILL	- AMBER - ON STEADY WHILE FILLING PAN
DRAIN	- AMBER - ON STEADY WHILE DRAINING PAN

IMPORTANT NOTE

ON THE INITIAL FILL AFTER INSTALLATION OR ANY TIME THE WATER PAN IS DRAINED THE PAN MUST FILL WITH ABOUT THREE (3) TIMES THE AMOUNT OF WATER AS REQUIRED IN THE NORMAL CYCLE OF FILLING. THE FILL TIMER MAY TIME OUT BEFORE THE WATER LEVEL REACHES THE WATER LEVEL PROBE CAUSING THE SERVICE CYCLE TO BE STARTED. IF THE WATER FAILURE ILLUMINATES, UNPLUG THE UNIT FROM ITS POWER SOURCE, WAIT ABOUT 15 SECONDS AND RECONNECT THE POWER SOURCE. THE SERVICE LIGHT WILL GO OUT AND THE UNIT WILL CONTINUE FILLING TO THE CORRECT LEVEL.

FIG. 7

SERVICE INDICATORS

A. The green "Power" light does not blink off and on.

1. The S2000 is not connected to an active 120 VAC 15 Amp power source. (S2020, 240 VAC, 10 AMP).
2. Call the Technical Support Hotline.

B. The "HEATER" LED does not illuminate.

1. The humidistat is not closed, calling for humidity or the humidistat is wired incorrectly.
2. The unit is in the maintenance cycle.

C. The HVAC Blower will not operate, but the "Blower" LED is on.

1. The blower "Field" wiring and/or interlock circuitry is incorrect.
2. The HVAC electric power is disconnected.
3. The humidifier internal "Blower" relay is defective. Call the Technical Support Hotline.
4. The HVAC Blower motor has failed.

D. The HVAC Blower will not operate and the "Blower" LED is not on.

1. The water pan temperature has not reached a high enough temperature to activate the "Blower" relay, about 170 degrees Fahrenheit. This takes several minutes after the "HEATER" LED is illuminated. Depending on the water temperature and the surrounding condition, this may take up to 12 minutes. If the problem continues, the heater element may be defective, the thermistor temperature probe may be defective. Contact the Technical Support Hotline.

E. Red Service Light (error #1) is on constantly.

THERMISTOR ...This is an indication that the temperature probe is open or shorted to ground. May also indicate the probe has detected a pan temperature below 32 degrees F. Or in excess of 230 degrees F., resulting in a total shutdown. Try to reset the unit by unplugging the cord and reconnecting, or call Technical Support.

F. Red Service Light (error #2) is on constantly.

WATER ...This is an indication that the water fill time has been exceeded. The water level did not reach the probe tip in the given amount of time. It may also indicate an unsuccessful drain cycle.

1. The water line is shut off at the saddle valve.
2. The water line is crimped or pinched.
3. The water valve inlet screen is plugged. Remove the water line from the unit and check the screen found inside the inlet side of the valve.
4. Unit is connected to a water source which is distilled, over-filtered, de-mineralized, or from a reverse osmosis system. **Minimum 25 ppm water conductivity is required. *The unit supply water must contain dissolved solids in the water, or the processor will not be able to detect the water level.**

5. The water valve may be defective and must be replaced See replacement parts.

6. The drain valve is unplugged or defective.

7. Debris is clogging the drain valve or drain line.

8. Reset the unit by unplugging the power cord and re-connecting.

G. Both Red Service Lights (error #3) are on.

HEATER FAILURE...This is an indication that the water temperature is not increasing or reaching the boiling point.

1. Faulty heater element or faulty wire connection.

2. This can happen if the unit is operated without water in the pan as a result of a water level probe malfunction, due to lack of maintenance. The pan boils dry and overheats the water pan. If this condition occurs, call the Technical Support Hotline.

3. The unit has operated for 45 minutes without a request for water, due to a leaking water fill valve, which is filling the tank continuously.

If the humidifier seems to operate in a random manner that doesn't seem to fit any of the pre-described conditions, check the following:

H. 1. Check to make sure that the wires used to connect the humidifier to the humidistat are separate wires and not part of a multi-wire bundle used to hook up the furnace thermostat or any other device. The associated close wires may create an induced voltage in the humidistat wiring.

2. Make sure that the water level probe and plastic insulator are clean and free of mineral build-up. It may become electrically conductive to ground, sensing a false indication that the water level is correct.

3. If the electric solenoid valve makes a loud noise when it closes, install an optional water hammer arrester to absorb the spike. Frequent or erratic water fill cycles can be due to air turbulence, when mounted in the supply air plenum.

4. The water probe uses the natural conductivity of the water, to determine the proper water level in the reservoir. Water that has been de-mineralized or over treated may not allow the unit to function properly. **Minimum 25 ppm of total dissolved solids must be present in the water. Add approximately 1 tablespoon of salt to the tank, to temporarily remedy this problem.**

5. These steam humidifiers must be connected to dedicated outlets of the proper current and voltage ratings. The use of extension cords is not recommended.

DO NOT cut off the grounded plug and/or hard wire this humidifier to line voltage.

This will void the warranty.

15. SERVICE AND REPLACEMENT PARTS

ITEM	S2000 PART NO.	S2020 PART NO.	DESCRIPTION OF PART
1	2120	—	120 VOLT HEATER ASSEMBLY
1	—	2240	240 VOLT HEATER ASSEMBLY
2	2001	2001	24 VOLT SOLENOID VALVE ASSEMBLY
3	2002	2002	THERMISTOR PROBE ASSEMBLY
4	2003	2003	WATER LEVEL PROBE ASSEMBLY
5	2004	2005	CIRCUIT BOARD ASSEMBLY
6	2006	2006	DRAIN VALVE ASSEMBLY
7	2007	2007	TANK BAFFLE
8	2008	2008	INSULATION KIT (not shown)
9	WH 100	WH 100	WATER HAMMER ARRESTER (not shown)
10	Z 100	Z 100	ANODE
11	2009	2009	UNDER DUCT STEAM COVER (not shown)

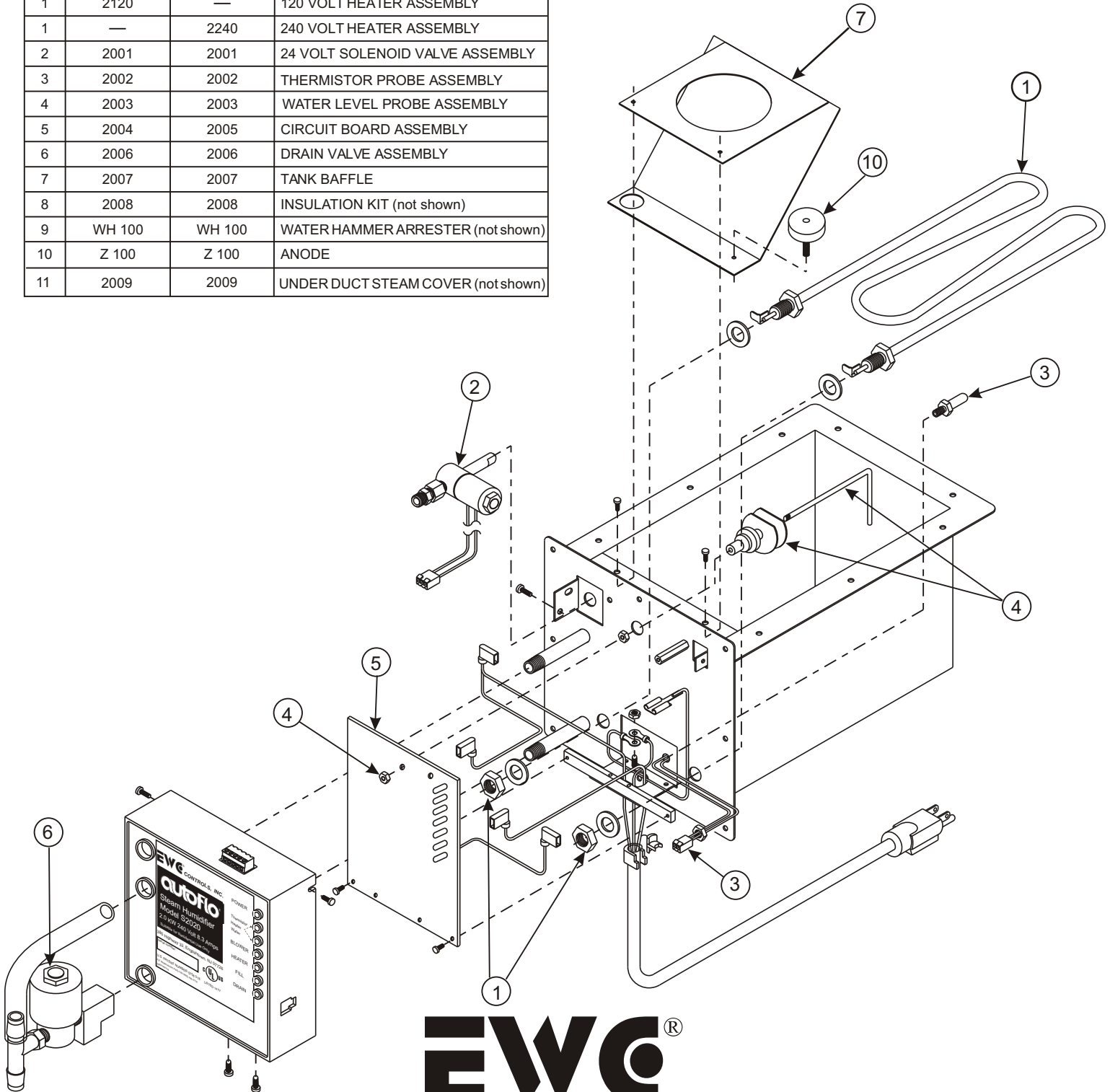

EWC[®]
CONTROLS INC.

385 Highway 33 • Englishtown, NJ 07726
 www.ewcccontrols.com e-mail: autoflo@ewcccontrols.com
 Tel. (800) 446-3110 Fax: (732) 635-8646

FIG. 8

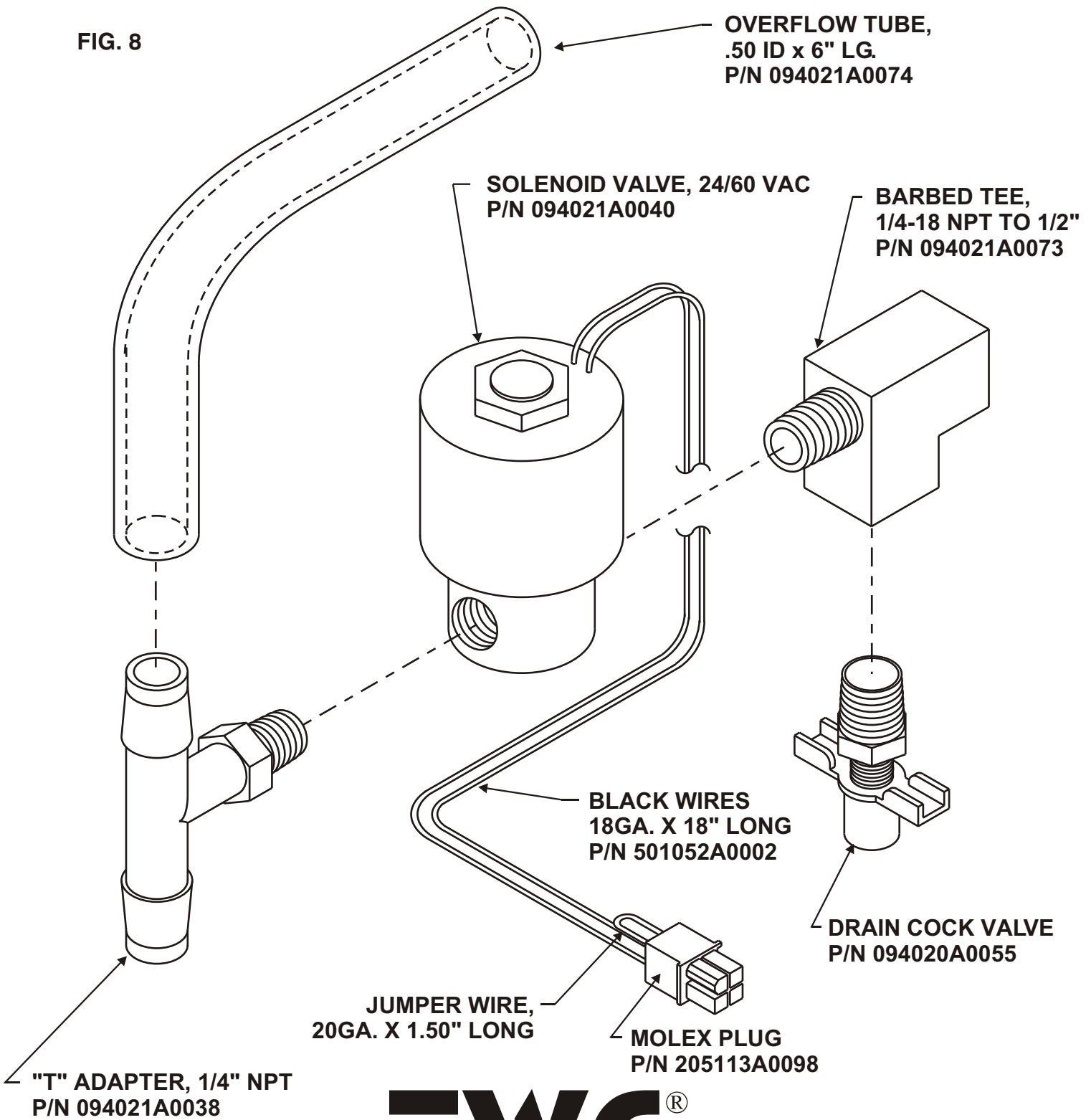

EWC®
CONTROLS INC.

385 Highway 33 • Englishtown, NJ 07726

www.ewccontrols.com

e-mail: autoflo@ewccontrols.com

Tel. (800) 446-3110

Fax: (732) 635-8646

Tech. (800) 526-4048

AUTOFLO HUMIDIFIER

Z100 ASSEMBLY

APPLICATION NOTE

AN 131

INSTALLATION INSTRUCTIONS & OWNER'S MANUAL
Z100 REPLACEMENT INSTRUCTIONS
SUPPLEMENT TO THE AUTOFLO ELECTRONIC STEAM POWER HUMIDIFIERS
MODEL # S2000 AND S2020

The *AUTOFLO* steam humidifier now comes equipped with a factory installed Z100, which acts as a sacrificial metal. Put simply, minerals in the water will attack and cling to the Z100. The minerals will not attack the other components inside the humidifier as long as the Z100 is present and active.

This results in a dramatic decrease in mineral and scale build up on the critical components inside the tank. In particular, it means less scale build up on the heating element which is subject to damage from excessive scaling and over heating. This also means that efficiency stays high and preventive maintenance is faster and easier.

The Z100 is positioned on the baffle plate inside the tank and is easily removed and replaced. Remember that the Z100's job is to become the target of mineral attack, so it will be heavily covered with scale and *should be replaced annually for best results.*

To remove the Z100 you must have already unplugged and shutdown your steam humidifier and allowed it to cool. The water tank has been drained, the water supply, drain lines and electrical wiring have been disconnected and the unit has been removed from the duct.

Refer to the blow up view on Page 8. Using a phillips screwdriver, remove the two screws that hold the baffle plate to the tank. Lift the baffle slightly back to clear the water probe and then straight up and out of the tank. You can then see the round Z100, or rather what is left of it after a single season. Notice the heavy scale build up on the Z100 that would have been on your element, if the Z100 was not there. Use a rag or pliers to grasp the edges of the Z100 and simply unscrew it from the baffle plate. Rinse off or wipe away any residual scale from the baffle plate and install a new Z100. Leave a slight gap between the bottom of the Z100 and the baffle plate. Now re-insert the baffle plate into the tank and secure with the two screws that were removed previously. It's that simple.

The Z100 can also benefit the older model steam humidifiers. Simply lay the Z100 down into the baffle plate in the same location as the factory installed model. *DO NOT lay the Z100 down into the main tank. It may come in contact with the heating element and damage it.* The dimensions of the baffle plate prevent the Z100 from falling down into the tank.

The Z100 is just the latest innovation in the *AUTOFLO* Steam Humidifier line as we continue in our pursuit of Excellence Without Compromise.

“S” series AutoFlo Steam Humidifier

IMPORTANT NOTES:

LOCATION:

Installing the steam unit in the attic is NOT recommended. Freezing temperatures, the possibility of flood damage, the possibility of producing an environment where mold can start, are all good reasons to avoid this location. However, a successful attic installation can be performed if the following components and safety measures are included:

1. A safety catch pan should be fabricated and installed directly underneath the entire air handler and the steam unit.
2. Safety catch pan should have a water sensor with fail open dry contacts wired in series with the Steamer control circuit.
3. The Fail safe blower interlock circuit on page 11 should be utilized with all devices included in the diagram.
4. Insulating the water supply line and drain lines is mandatory. If code allows, apply heat tape to the water supply line and then insulate it.
5. A decision to operate the Steamer without the automatic drain valve may be necessary, if a suitable downgrade slope to drain is not available. The drain lines should never be trapped, kinked, or routed above the Steamer.
6. A separate High Humidity cut-out should be mounted in the attic itself, and wired in series with the Steamer control circuit.
7. Routine maintenance of the Steamer must be adhered to, and annual inspections for moisture and/or mold on the wood surfaces should be performed.
8. All ductwork must be completely sealed as the source of excess moisture in the attic will come from leaky ductwork.

WATER SUPPLY:

1. Remember, the Steamer water supply must measure minimum 25 ppm conductivity in order for the processor to reliably detect the presence of water and the proper water level.
2. Plastic 1/4" water supply tubing is supplied in the box for you however, we recommend the use of copper tubing in most applications as it is stronger, more reliable, and can support the weight of the WH100 water hammer arrester.
3. Use of a water hammer is highly recommended to dampen out water spikes when the Steamer opens & closes the valve.

Field Notes: