

Friedrich

Service Manual

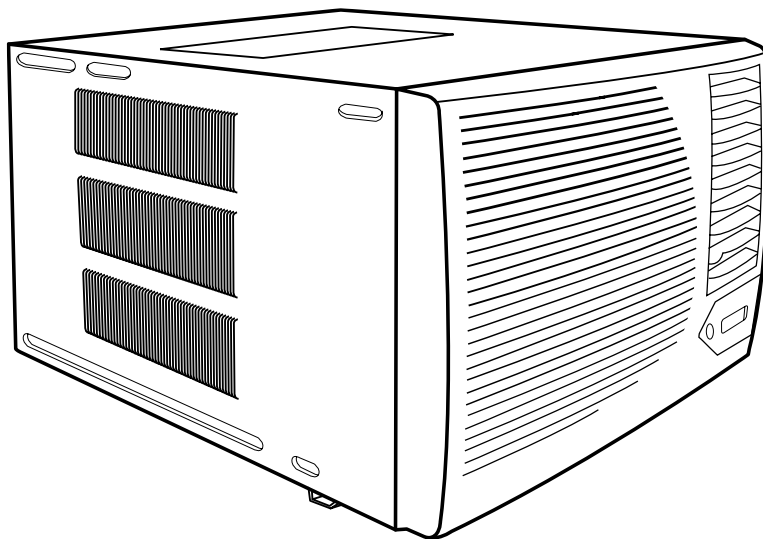

Compact Programmable

Models

2009

2008

TECHNICAL SUPPORT CONTACT INFORMATION



FRIEDRICH AIR CONDITIONING CO.

Post Office Box 1540 · San Antonio, Texas 78295-1540
4200 N. Pan Am Expressway · San Antonio, Texas 78218-5212
(210) 357-4400 · FAX (210) 357-4490
www.friedrich.com

Printed in the U.S.A.

Table Of Contents

Important Safety Information	2-4
Introduction	4
Unit Identification	5
Electrical Data	6-7
Specifications and Performance Data	8-9
Functional Components Definitions	10
Air Conditioner Use	10
How to Operate the Friedrich CP Room Air Conditioner	11-12
Refrigeration Sequence of Operation	13
Sealed Refrigeration System Repairs	14-17
Method of Charging/Repairs	15
Metering Device	18
Compressor Checks	18-22
Routine Maintenance	23-24
Troubleshooting	25-28
Wiring Diagrams for 2009 Models	29
Wiring Diagrams for 2008 Models	30
Parts for 2009 Models	31-34
Parts for 2008 Models	35-37
Warranty	38

IMPORTANT SAFETY INFORMATION

The information contained in this manual is intended for use by a qualified service technician who is familiar with the safety procedures required for installation and repair, and who is equipped with the proper tools and test instruments required to service this product.

Installation or repairs made by unqualified persons can result in subjecting the unqualified person making such repairs as well as the persons being served by the equipment to hazards resulting in injury or electrical shock which can be serious or even fatal.

Safety warnings have been placed throughout this manual to alert you to potential hazards that may be encountered. If you install or perform service on equipment, it is your responsibility to read and obey these warnings to guard against any bodily injury or property damage which may result to you or others.

Your safety and the safety of others are very important.

We have provided many important safety messages in this manual and on your appliance. Always read and obey all safety messages.



This is a safety Alert symbol.

This symbol alerts you to potential hazards that can kill or hurt you and others.

All safety messages will follow the safety alert symbol with the word "WARNING" or "CAUTION". These words mean:



You can be killed or seriously injured if you do not follow instructions.



You can receive minor or moderate injury if you do not follow instructions.

All safety messages will tell you what the potential hazard is, tell you how to reduce the chance of injury, and tell you what will happen if the instructions are not followed.



A message to alert you of potential property damage will have the word "NOTICE". Potential property damage can occur if instructions are not followed.

PERSONAL INJURY OR DEATH HAZARDS

ELECTRICAL HAZARDS:

- Unplug and/or disconnect all electrical power to the unit before performing inspections, maintenance, or service.
- Make sure to follow proper lockout/tag out procedures.
- Always work in the company of a qualified assistant if possible.
- Capacitors, even when disconnected from the electrical power source, retain an electrical charge potential capable of causing electric shock or electrocution.
- Handle, discharge, and test capacitors according to safe, established, standards, and approved procedures.
- Extreme care, proper judgment, and safety procedures must be exercised if it becomes necessary to test or troubleshoot equipment with the power on to the unit.

- Do not spray or pour water on the return air grille, discharge air grille, evaporator coil, control panel, and sleeve on the room side of the air conditioning unit while cleaning.
- Electrical component malfunction caused by water could result in electric shock or other electrically unsafe conditions when the power is restored and the unit is turned on, even after the exterior is dry.
- Never operate the A/C unit with wet hands.
- Use air conditioner on a single dedicated circuit within the specified amperage rating.
- Use on a properly grounded outlet only.
- Do not remove ground prong of plug.
- Do not cut or modify the power supply cord.
- Do not use extension cords with the unit.
- Follow all safety precautions and use proper and adequate protective safety aids such as: gloves, goggles, clothing, adequately insulated tools, and testing equipment etc.
- Failure to follow proper safety procedures and/or these warnings can result in serious injury or death.

REFRIGERATION SYSTEM HAZARDS:

- Use approved standard refrigerant recovering procedures and equipment to relieve pressure before opening system for repair.
- Do not allow liquid refrigerant to contact skin. Direct contact with liquid refrigerant can result in minor to moderate injury.
- Be extremely careful when using an oxy-acetylene torch. Direct contact with the torch's flame or hot surfaces can cause serious burns.
- Make sure to protect personal and surrounding property with fire proof materials.
- Have a fire extinguisher at hand while using a torch.
- Provide adequate ventilation to vent off toxic fumes, and work with a qualified assistant whenever possible.
- Always use a pressure regulator when using dry nitrogen to test the sealed refrigeration system for leaks, flushing etc.
- Make sure to follow all safety precautions and to use proper protective safety aids such as: gloves, safety glasses, clothing etc.
- Failure to follow proper safety procedures and/or these warnings can result in serious injury or death.

MECHANICAL HAZARDS:

- Extreme care, proper judgment and all safety procedures must be followed when testing, troubleshooting, handling, or working around unit with moving and/or rotating parts.
- Be careful when, handling and working around exposed edges and corners of sleeve, chassis, and other unit components especially the sharp fins of the indoor and outdoor coils.
- Use proper and adequate protective aids such as: gloves, clothing, safety glasses etc.
- Failure to follow proper safety procedures and/or these warnings can result in serious injury or death.

PROPERTY DAMAGE HAZARDS

FIRE DAMAGE HAZARDS:

- Read the Installation/Operation Manual for this air conditioning unit prior to operating.
- Use air conditioner on a single dedicated circuit within the specified amperage rating.
- Connect to a properly grounded outlet only.
- Do not remove ground prong of plug.
- Do not cut or modify the power supply cord.
- Do not use extension cords with the unit.
- Failure to follow these instructions can result in fire and minor to serious property damage.

WATER DAMAGE HAZARDS:

- Improper installation maintenance, or servicing of the air conditioner unit, or not following the above Safety Warnings can result in water damage to personal items or property.
- Insure that the unit has a sufficient pitch to the outside to allow water to drain from the unit.
- Do not drill holes in the bottom of the drain pan or the underside of the unit.
- Failure to follow these instructions can result in result in damage to the unit and/or minor to serious property damage.

INTRODUCTION

This service manual is designed to be used in conjunction with the installation manuals provided with each unit.

This service manual was written to assist the professional HVAC service technician to quickly and accurately diagnose and repair any malfunctions of this product.

This manual, therefore, will deal with all subjects in a general nature. (i.e. All text will pertain to all models).

IMPORTANT: It will be necessary for you to accurately identify the unit you are servicing, so you can be certain of a proper diagnosis and repair. (See Unit Identification.)

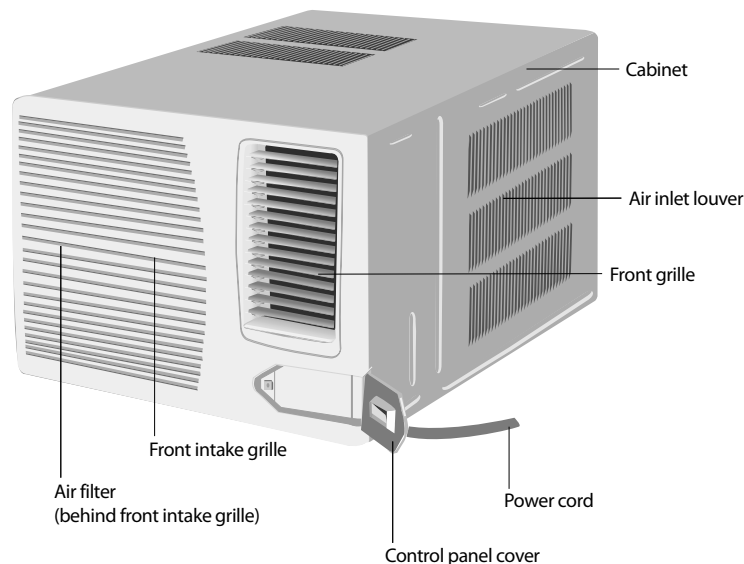

UNIT IDENTIFICATION

Model Number Code

C P 08 E 1 0

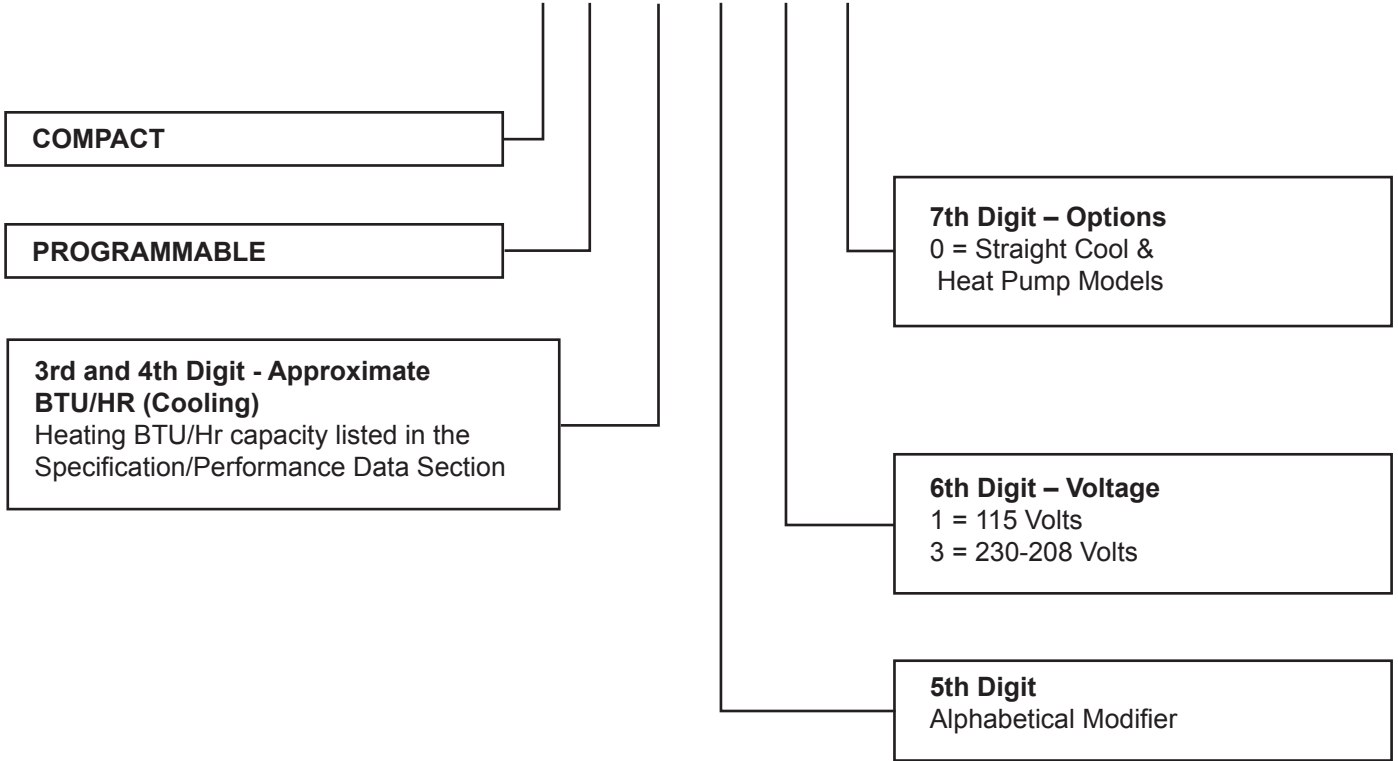

RAC Serial Number Identification Guide

Serial Number Decade Manufactured L=0 C=3 F=6 J=9 A=1 D=4 G=7 B=2 E=5 H=8	L	H	G	K	00001 Production Run Number
Year Manufactured A=1 D=4 G=7 K=0 B=2 E=5 H=8 C=3 F=6 J=9					Product Line K = RAC
Month Manufactured A=Jan D=Apr G=Jul K=Oct B=Feb E=May H=Aug L=Nov C=Mar F=Jun J=Sept M=Dec					



ELECTRICAL DATA

⚠ WARNING	
	<p>ELECTRIC SHOCK HAZARD Turn off electric power before service or installation.</p> <p>All electrical connections and wiring MUST be installed by a qualified electrician and conform to the National Electrical Code and all local codes which have jurisdiction.</p> <p>Failure to do so can result in personal injury or death.</p>

NOTICE
<p style="text-align: center;">FIRE HAZARD</p> <p>Not following the above WARNING could result in fire or electrically unsafe conditions which could cause moderate or serious property damage.</p> <p>Read, understand and follow the above warning.</p>

- Wire Size** Use ONLY wiring size recommended for single outlet branch circuit.
- Fuse/Circuit Breaker** Use ONLY the correct HACR type and size fuse/circuit breaker. Read electrical ratings on unit's rating plate. Proper circuit protection is the responsibility of the homeowner.
- Grounding** Unit **MUST** be grounded from branch circuit through service cord to unit, or through separate ground wire provided on permanently connected units. Be sure that branch circuit or general purpose outlet is grounded. Ground wire must be connected to ground screw located in lower right corner of air conditioner when air conditioner is in cabinet. (CP 14, 18, 24)
- Receptacle** The field supplied outlet must match plug on service cord and be within reach of service cord. Do **NOT** alter the service cord or plug. Do **NOT** use an extension cord. Refer to the table above for proper receptacle and fuse type.

Plug/Outlet/Circuit Rating

Model	Circuit Rating Breaker or T-D Fuse	Plug Face (NEMA#)	Power Cord Length (ft.)	Wall Outlet Appearance
CP14	125V - 15A	5 - 15P	6	
CP18	250V - 15A	6 - 15P	4	
CP24	250V - 20A	6 - 20P	4	



Recommended grounding method

This air conditioner must be grounded. This air conditioner is equipped with a power supply cord having a grounded 3 prong plug. To minimize possible shock hazard, the cord must be plugged into a mating, grounded 3 prong outlet, grounded in accordance with all local codes and ordinances. If a mating outlet is not available, it is the customer's responsibility to have a properly grounded 3 prong outlet installed by a qualified electrical component installer. It is the customer's responsibility:

To contact a qualified electrical installer, and to assure that the electrical installation is adequate and in conformance with National Electrical Code, ANSI/NFPA 70 - latest edition, and all local codes and ordinances.

Copies of the standards listed may be obtained from:

National Fire Protection Association
One Batterymarch Park
Quincy, MA 02269

Power Supply Cord

NOTE: Your unit's device may differ from the ones shown.

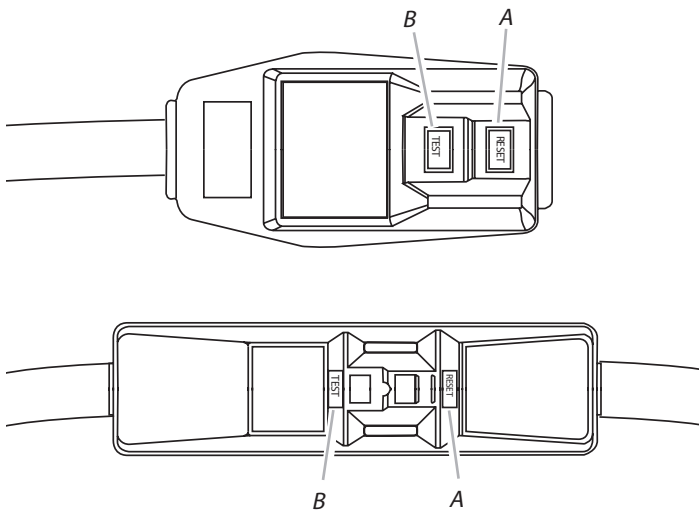

A. Reset button
B. Test button

This room air conditioner is equipped with a power supply cord required by UL. This power supply cord contains state-of-the-art electronics that sense leakage current. If the cord is crushed, the electronics detect leakage current and power will be disconnected in a fraction of a second.

⚠ WARNING



ELECTRICAL SHOCK HAZARD

Plug into a grounded 3 prong outlet.
Do not remove powercord ground prong.
Do not use a plug adapter.
Do not use an extension cord.
Failure to follow these instructions can result in death, fire, or electrical shock.

To test your power supply cord:

1. Plug power supply cord into a grounded 3 prong outlet.
2. Press RESET.
3. Press TEST (listen for click; Reset button will trip and pop out).
4. Press and release RESET (listen for click; Reset button will latch and remain in). The power supply cord is ready for operation.

NOTES:

The Reset button must be pushed in for proper operation.

The power supply cord must be replaced if it fails to trip when the test button is pressed or if it fails to reset.

Do not use the power supply cord as an off/on switch. The power supply cord is designed as a protective device.

A damaged power supply cord must be replaced with a new power supply cord obtained from the product manufacturer and must not be repaired.

The power supply cord contains no user serviceable parts. Opening the tamper-resistant case voids all warranty and performance claims.

SPECIFICATIONS FOR 2009 MODELS

Model		CP14E10	CP18E30	CP24E30
Function		COOLING	COOLING	COOLING
Rated Voltage		115V	208~230V	208~230V
Rated Frequency		60Hz	60Hz	60Hz
Total Capacity (W/Btu/h)		14700(Btu/h)	18000 /18450(Btu/h)	24900 /25200 (Btu/h)
Power Input (W)		1370	1680/1730	2660/2690
Rated Input (W)		1757W	2259W	3295W
Rated Current (A)		17.61A	9.02A	15A
Air Flow Volume (CFM) (H/M/L)		798/730/696	968/918/866	1002/950/866
Dehumidifying Volume (pints/h)		5.28	5.92	9.93
EER		10.8	10.8 / 10.8	9.4 / 9.4
Indoor Side	Fan Type-Piece	Centrifugal flow fan – 1	Centrifugal flow fan – 1	Centrifugal flow fan – 1
	Diameter-Length (inch)	8.82 X 4.31	8.82 X 4.31	8.82 X 4.31
	Evaporator	Aluminum fin-copper tube	Aluminum fin-copper tube	Aluminum fin-copper tube
	Pipe Diameter (inches)	.276	.276	.276
	Coil length (l) x height (H) x coil width (L)	422 X 381 X 25.4	422 X 381 X 25.4	422 X 381 X 25.4
Outdoor Side	Compressor Type	Rotary	Rotary	Rotary
	L.R.A. (A)	61	42	60
	Compressor RLA(A)	11.5	7.5	11.2/10.7
	Compressor Power Input(W)	1060	1606	2310/2390
	Overload Protector	External	Internal	Internal
	Throttling Method	Capillary	Capillary	Capillary
	Starting Method	Capacitor	Capacitor	Capacitor
	Working Temp Range (°F)	50°-115°	50°-115°	50°-115°
	Condenser	Aluminum fin-copper tube	Aluminum fin-copper tube	Aluminum fin-copper tube
	Fan Type-Piece	Axial fan –1	Axial fan –1	Axial fan –1
	Fan Diameter (inches)	15.59	15.59	15.59
Fan Motor Speed (rpm) (H/M/L)	900/780/730	1000/900/800	1060/970/820	
Output of Fan Motor (W)	205	297	320	
Fan Motor RLA(A)	1.78	1.29	1.39	
Fan Motor Capacitor (uF)	15	7	7	
Permissible Excessive Operating Pressure for the Discharge Side(PSI)	300	300	300	
Permissible Excessive Operating Pressure for the Suction Side(PSI)	150	150	150	
Dimension (W/H/D)	17½ X 26 X 27¾	17½ X 26 X 29¾	17½ X 26 X 29¾	
Net Weight	121	141	165	
Refrigerant Charge (oz)	R22/28.57	R22/32.10	R22/37.04	

Performance Data

PERFORMANCE DATA* Cooling	EVAP. AIR TEMP. DEG. F		CONDENSER TEMPERATURE DEG. F	Discharge Temp	Suction Temp	Super Heat	Sub-Cooling	OPERATING PRESSURES		ELECTRICAL RATINGS			R-22 REF. Charge in OZ.	Voltage	BREAKER FUSE 60 Hertz Amps
	Discharge Air	Temp. Drop F.						Suction	Discharge	Amps Cool	Amps Heat	Locked Rotor Amps			
CP14N10	59	21	118	173	56	41	54	78	267	12.1	/	58	26.5	115	15
CP18N30	58	22	119	173	66	52	55	77	269	8.3	/	38.9/42.4	27.9	230	15
	57	23	119	172	66	52	55	77	269	8.5	/				
CP24N30	57	23	117	197	60	44	50	75	264	12.3	/	56A(230V)	33.5	230	20
	56	24	117	195	57	44	50	75	264	13.1	/				

*Rating Conditions: 80 degrees F, room air temp. & 50% relative humidity, with 95 degree F, outside air temp & 40% relative humidity.

SPECIFICATIONS FOR 2008 MODELS

Model		CP14N10	CP18N30	CP24N30
Function		COOLING	COOLING	COOLING
Rated Voltage		115V	230V/208V~	230V/208V~
Rated Frequency		60Hz	60Hz	60Hz
Total Capacity (W/Btu/h)		14000(Btu/h)	18000 /17600(Btu/h)	23500/23100(Btu/h)
Power Input (W)		1430	1850/1810	2740/2710
Rated Input (W)		1540W	2478W	3538W
Rated Current (A)		15A	12.57A	18.09A
Air Flow Volume (CFM) (H/M/L)		458.8	458.8	617.6
Dehumidifying Volume (pints/h)		3.38	4.65	8.46
EER		9.8	9.7 / 9.7	8.6 / 8.5
Indoor Side	Fan Type-Piece	Centrifugal flow fan – 1	Centrifugal flow fan – 1	Centrifugal flow fan – 1
	Diameter-Length (inch)	7.93 X4.31	7.93 X4.31	8.82 X4.31
	Evaporator	Aluminum fin-copper tube	Aluminum fin-copper tube	Aluminum fin-copper tube
	Pipe Diameter (inches)	0.276	0.276	0.276
	Coil length (l) x height (H) x coil width (L)	16.61 X 15 X 1	16.61 X 15 X 1	16.61 X 15 X 1
Outdoor Side	Compressor Type	Rotary	Rotary	Rotary
	L.R.A. (A)	58	42	56
	Compressor RLA(A)	10.9	7.45	11.7/11.0
	Compressor Power Input(W)	1182	1700	2425/2480
	Overload Protector	External	External	Internal
	Throttling Method	Capillary	Capillary	Capillary
	Starting Method	Capacitor	Capacitor	Capacitor
	Working Temp Range (°F)	50°-115°	50°-115°	50°-115°
	Condenser	Aluminum fin-copper tube	Aluminum fin-copper tube	Aluminum fin-copper tube
	Fan Type-Piece	Axial fan –1	Axial fan –1	Axial fan –1
Fan Diameter (inches)	15.59	15.59	15.59	
Fan Motor Speed (rpm) (H/M/L)		900/780/730	900/780/730	1000/900/800
Output of Fan Motor (W)		200	200	190
Fan Motor RLA(A)		3	1.45	1.35
Fan Motor Capacitor (uF)		15	7	7
Permissible Excessive Operating Pressure for the Discharge Side(PSI)		300	300	300
Permissible Excessive Operating Pressure for the Suction Side(PSI)		150	150	150
Dimension (W/H/D)		17½ X 26 X 27¾	17½ X 26 X 27¾	17½ X 26 X 29¾
Net Weight		121	141	165
Refrigerant Charge (oz)		R22/26.46	R22/27.87	R22/33.51

Performance Data

PERFORMANCE DATA* Cooling	EVAP. AIR TEMP. DEG. F		CONDENSER TEMPERATURE DEG. F	Discharge Temp	Suction Temp	Super Heat	Sub-Cooling	OPERATING PRESSURES		ELECTRICAL RATINGS			R-22 REF. Charge in OZ.	Voltage	BREAKER FUSE 60 Hertz Amps
	Discharge Air	Temp. Drop F.						Suction	Discharge	Amps Cool	Amps Heat	Locked Rotor Amps			
CP14N10	59	21	118	173	56	41	54	78	267	12.1	/	58	26.5	115	15
CP18N30	58	22	119	173	66	52	55	77	269	8.3	/	38.9/42.4	27.9	230	15
	57	23	119	172	66	52	55	77	269	8.5	/			208	
CP24N30	57	23	117	197	60	44	50	75	264	12.3	/	56A(230V)	33.5	230	20
	56	24	117	195	57	44	50	75	264	13.1	/			208	

*Rating Conditions: 80 degrees F, room air temp. & 50% relative humidity, with 95 degree F, outside air temp & 40% relative humidity.

COMPONENT DEFINITIONS

A. Mechanical components

Vent door

Exhausts stale room air outside.

Plenum assembly

Diffuser with directional louvers used to direct the conditioned airflow.

Blower wheel

Attaches to the indoor side of the fan motor shaft and is used for distributing unconditioned, room side air through the heat exchanger and delivering conditioned air into the room.

Slinger fan blade

Attaches to the outdoor side of the fan motor shaft and is used to move outside air through the condenser coil, while slinging condensate water out of the base pan and onto the condenser coil, thus lowering the temperature and pressures within the coil.

B. Electrical components

Thermistor

A sensor that automatically responds to temperature changes.

Capacitor

Reduces line current and steadies the voltage supply, while greatly improving the torque characteristics of the fan motor and compressor motor.

MoneySaver® switch

Used to regulate the operation of the fan motor and the compressor or to turn the unit off. For troubleshooting, refer to the wiring diagrams and schematics in the back of this service manual.

Fan Motor

Dual-shafted fan motor operates the indoor blower wheel and the condenser fan blade simultaneously.

C. Hermetic components

Compressor

Motorized device used to compress refrigerant through the sealed system.

Capillary tube

A cylindrical meter device used to evenly distribute the flow of refrigerant to the heat exchangers (coils).

AIR CONDITIONER USE

Operating the air conditioner properly helps you to obtain the best possible results.

This section explains proper air conditioner operation.

IMPORTANT:

If you turn off the air conditioner, wait at least 3 minutes before turning it back on. This prevents the air conditioner from blowing a fuse or tripping a circuit breaker.

Do not try to operate your air conditioner in the cooling mode when outside temperature is below 65°F (18°C). The inside evaporator coil will freeze up, and the air conditioner will not operate properly.

NOTE: In the event of a power failure, your air conditioner will operate at the previous settings when the power is restored.

How to operate the Friedrich room air conditioner

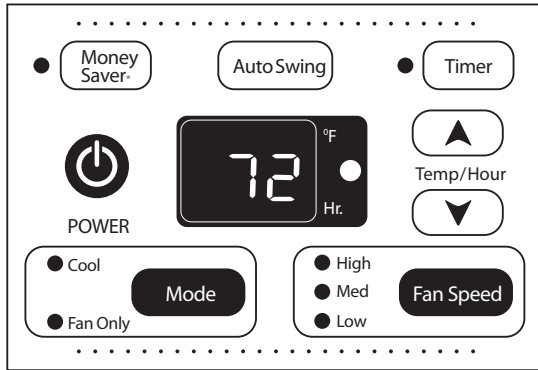

1. Press POWER to turn on air conditioner.



POWER

NOTE: When the unit is turned on, it will display the previous settings for the Mode, Fan Speed and temperature.

2. Choose mode. See "Mode."
3. Choose fan speed. See "Fan Speed."
4. Choose temperature. See "Temperature."

Mode

1. Press and hold MODE.
2. Choose Cool or Fan mode
 - Cool—Cools room. Press FAN SPEED to choose fan speed. Then adjust the temperature by pressing the up or down arrow buttons.
 - Fan—Operates the fan at High speed, without cooling. The display shows "FO" (fan only).

Money Saver

- Money Saver — Turns fan to low speed when room temperature reaches the temperature setting on the thermostat.



Fan Speed

NOTE: The Fan Speed button will operate only when the Cool or Power Saver mode has been selected.

1. Press and hold FAN SPEED until you see the indicator light for the desired setting.
2. Choose High, Medium or Low.



Temperature

Press, or press and hold, the plus button to raise the temperature 1° until it reaches 86°F (30°C).



Press, or press and hold, the minus button to lower the temperature 1° until it reaches 64°F (18°C).

Timer Delay

To set the Timer for a 1- to 24-hour delay until the air conditioner turns off (the air conditioner must be On):

1. Press TIMER. Indicator light will flash.
 
2. Press the plus or minus button to change the delay time from 1 to 24 hours.
3. Press TIMER or wait 10 seconds. Indicator light will remain on.

To set the Timer delay for a 1- to 24-hour delay until the air conditioner turns on, keeping previous settings:

1. Turn off air conditioner.
2. Press TIMER. Indicator light will flash.
3. Press the plus or minus button to change the delay time from 1 to 24 hours.
4. Press TIMER or wait 10 seconds. Indicator light will remain on.

To set the Timer delay for a 1- to 24-hour delay until the air conditioner turns on, changing previous settings:

1. Turn on air conditioner.
2. Adjust MODE to desired setting.
3. Adjust FAN SPEED to High, Medium or Low.
4. Adjust temperature between 64°F (18°C) and 86°F (30°C).
5. Turn off air conditioner.
6. Press TIMER. Indicator light will flash.
7. Press the plus or minus button to change delay time from 1 to 24 hours.
8. Press TIMER or wait 10 seconds.

To clear Timer delay program

NOTE: Air conditioner can be either on or off.

Press and hold TIMER for 3 seconds. Indicator light will turn off.

To see the time remaining (in hours)

1. Press TIMER once after it has been set.
2. While the display is showing the remaining time, you can press the plus or minus button to increase or decrease the time.

To operate air conditioner with remote control

NOTE: Remote control may vary in appearance.

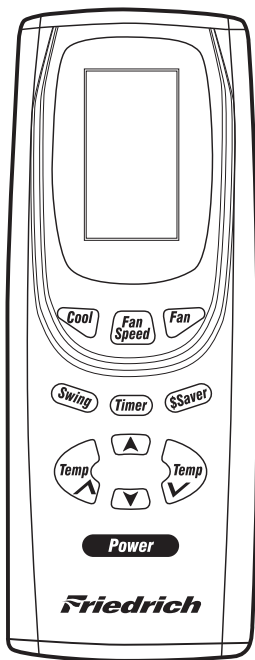

NOTE: Two AAA batteries (included) power the remote control. Replace batteries after 6 months of use, or when the remote control starts to lose power.

To turn the air conditioner on or off:
Press POWER.



To select the mode:
Press COOL, FAN or \$ SAVER

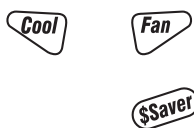

To select the fan speed:
Press FAN SPEED for High, Medium or Low.



To raise the temperature:

Press the plus button to raise the temperature. Each time you press or hold the plus button, the temperature will go up 1° until it reaches 86°F (30°C).



To lower the temperature:

Press the minus button to lower the temperature. Each time you press or hold the minus button, the temperature will go down 1° until it reaches 64°F (18°C).



To set Timer for a 1- to 24-hour delay before air conditioner is turned off (air conditioner must be On):

1. Press TIMER. Indicator light on air conditioner control panel will flash.



2. Press the plus or minus button to change the delay time from 1 to 24 hours.
3. Press TIMER again or wait 10 seconds. Indicator light on air conditioner control panel will remain on.

To set Timer to turn on air conditioner, keeping previous settings:

1. Turn off air conditioner.
2. Press TIMER. Indicator light on air conditioner control panel will flash.
3. Press the plus or minus button to change delay time (1 to 24 hours).
4. Press TIMER again or wait 10 seconds. Indicator light on air conditioner control panel will remain on.

To set Timer to turn on air conditioner, changing the previous settings:

1. Turn on air conditioner.
2. Adjust Mode to Cool, Fan Only, or Power Saver.
3. Adjust Fan Speed to High, Medium or Low.
4. Adjust temperature between 64°F (18°C) and 86°F (30°C).
5. Turn off air conditioner.
6. Press TIMER. Indicator light on air conditioner control panel will flash.
7. Press the plus or minus button to change delay time (1 to 24 hours).
8. Press TIMER again or wait 10 seconds. Indicator light on air conditioner control panel will remain on.

REFRIGERATION SYSTEM SEQUENCE OF OPERATION

A good understanding of the basic operation of the refrigeration system is essential for the service technician. Without this understanding, accurate troubleshooting of refrigeration system problems will be more difficult and time consuming, if not (in some cases) entirely impossible. The refrigeration system uses four basic principles (laws) in its operation they are as follows:

1. "Heat always flows from a warmer body to a cooler body."
2. "Heat must be added to or removed from a substance before a change in state can occur"
3. "Flow is always from a higher pressure area to a lower pressure area."
4. "The temperature at which a liquid or gas changes state is dependent upon the pressure."

The refrigeration cycle begins at the compressor. Starting the compressor creates a low pressure in the suction line which draws refrigerant gas (vapor) into the compressor. The compressor then "compresses" this refrigerant, raising its pressure and its (heat intensity) temperature.

The refrigerant leaves the compressor through the discharge line as a hot High pressure gas (vapor). The refrigerant enters the condenser coil where it gives up some of its heat. The condenser fan moving air across the coil's finned surface facilitates the transfer of heat from the refrigerant to the relatively cooler outdoor air.

When a sufficient quantity of heat has been removed from the refrigerant gas (vapor), the refrigerant will "condense" (i.e. change to a liquid). Once the refrigerant has been condensed (changed) to a liquid it is cooled even further by the air that continues to flow across the condenser coil.

The RAC design determines at exactly what point (in the condenser) the change of state (i.e. gas to a liquid) takes place. In all cases, however, the refrigerant must be totally condensed (changed) to a Liquid before leaving the condenser coil.

The refrigerant leaves the condenser Coil through the liquid line as a warm high pressure liquid. It next will pass through the refrigerant drier (if so equipped). It is the function of the drier to trap any moisture present in the system, contaminants, and large particulate matter.

The liquid refrigerant next enters the metering device. The metering device is a capillary tube. The purpose of the metering device is to "meter" (i.e. control or measure) the quantity of refrigerant entering the evaporator coil.

In the case of the capillary tube this is accomplished (by design) through size (and length) of device, and the pressure difference present across the device.

Since the evaporator coil is under a lower pressure (due to the suction created by the compressor) than the liquid line, the liquid refrigerant leaves the metering device entering the evaporator coil. As it enters the evaporator coil, the larger area and lower pressure allows the refrigerant to expand and lower its temperature (heat intensity). This expansion is often referred to as "boiling". Since the unit's blower is moving indoor air across the finned surface of the evaporator coil, the expanding refrigerant absorbs some of that heat. This results in a lowering of the indoor air temperature, hence the "cooling" effect.

The expansion and absorbing of heat cause the liquid refrigerant to evaporate (i.e. change to a gas). Once the refrigerant has been evaporated (changed to a gas), it is heated even further by the air that continues to flow across the evaporator coil.

The particular system design determines at exactly what point (in the evaporator) the change of state (i.e. liquid to a gas) takes place. In all cases, however, the refrigerant must be totally evaporated (changed) to a gas before leaving the evaporator coil.

The low pressure (suction) created by the compressor causes the refrigerant to leave the evaporator through the suction line as a cool low pressure vapor. The refrigerant then returns to the compressor, where the cycle is repeated.

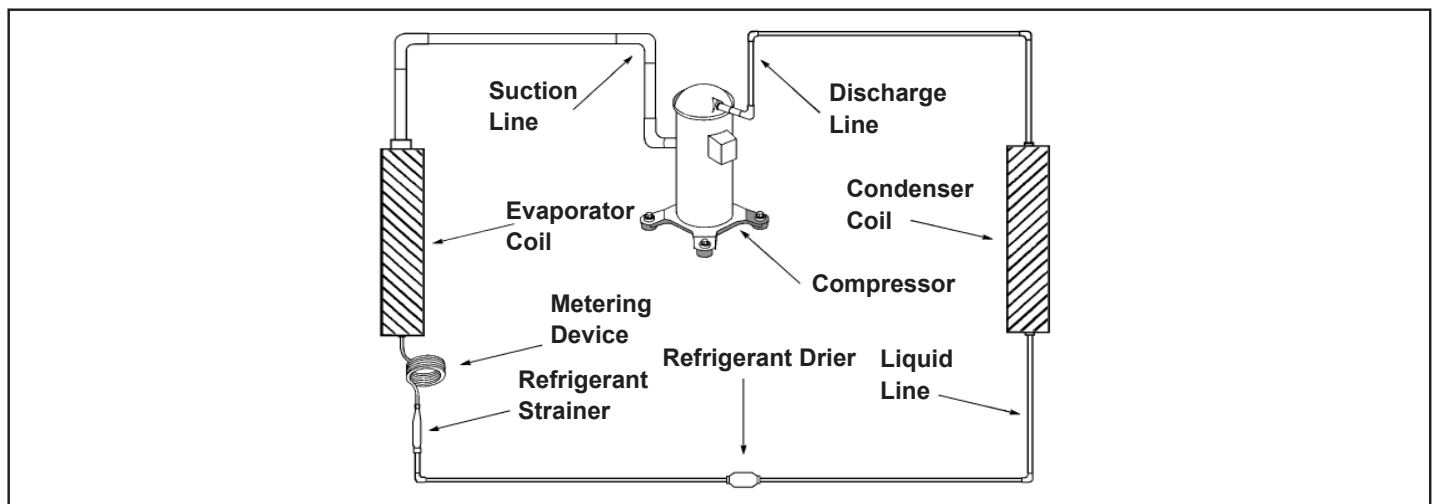

SEALED REFRIGERATION SYSTEM REPAIRS

IMPORTANT

ANY SEALED SYSTEM REPAIRS TO COOL-ONLY MODELS REQUIRE THE INSTALLATION OF A LIQUID LINE DRIER. ALSO, ANY SEALED SYSTEM REPAIRS TO HEAT PUMP MODELS REQUIRE THE INSTALLATION OF A SUCTION LINE DRIER.



EQUIPMENT REQUIRED:

1. Voltmeter
2. Ammeter
3. Ohmmeter
4. E.P.A. Approved Refrigerant Recovery System
5. Vacuum Pump (capable of 200 microns or less vacuum.)
6. Acetylene Welder
7. Electronic Halogen Leak Detector (G.E. Type H-6 or equivalent.)
8. Accurate refrigerant charge measuring device such as:
 - a. Balance Scales - 1/2 oz. accuracy
 - b. Charging Board - 1/2 oz. accuracy



9. High Pressure Gauge - (0 - 400 lbs.)
10. Low Pressure Gauge - (30 - 150 lbs.)
11. Vacuum Gauge - (0 - 1000 microns)

EQUIPMENT MUST BE CAPABLE OF:

1. Recovery CFC's as low as 5%.
2. Evacuation from both the high side and low side of the system simultaneously.
3. Introducing refrigerant charge into high side of the system.
4. Accurately weighing the refrigerant charge actually introduced into the system.
5. Facilities for flowing nitrogen through refrigeration tubing during all brazing processes.

 WARNING	
	RISK OF ELECTRIC SHOCK Unplug and/or disconnect all electrical power to the unit before performing inspections, maintenances or service.
	Failure to do so could result in electric shock, serious injury or death.

Proper refrigerant charge is essential to proper unit operation. Operating a unit with an improper refrigerant charge will result in reduced performance (capacity) and/or efficiency. Accordingly, the use of proper charging methods during servicing will insure that the unit is functioning as designed and that its compressor will not be damaged.

 WARNING	
	HIGH PRESSURE HAZARD Sealed Refrigeration System contains refrigerant and oil under high pressure.
	Proper safety procedures must be followed, and proper protective clothing must be worn when working with refrigerants. Failure to follow these procedures could result in serious injury or death.

Too much refrigerant (overcharge) in the system is just as bad (if not worse) than not enough refrigerant (undercharge). They both can be the source of certain compressor failures if they remain uncorrected for any period of time. Quite often, other problems (such as low air flow across evaporator, etc.) are misdiagnosed as refrigerant charge problems. The refrigerant circuit diagnosis chart will assist you in properly diagnosing these systems.

An overcharged unit will at times return liquid refrigerant (slugging) back to the suction side of the compressor eventually causing a mechanical failure within the compressor. This mechanical failure can manifest itself as valve failure, bearing failure, and/or other mechanical failure. The specific type of failure will be influenced by the amount of liquid being returned, and the length of time the slugging continues.

Refrigerant Charging

NOTE: Because The RAC System Is A Sealed System, Service Process Tubes Will Have To Be Installed. First Install A Line Tap And Remove Refrigerant From System. Make Necessary Sealed System Repairs And Vacuum System. Crimp Process Tube Line And Solder End Shut. Do Not Leave A Service Valve In The Sealed System.

Not enough refrigerant (undercharge) on the other hand, will cause the temperature of the suction gas to increase to the point where it does not provide sufficient cooling for the compressor motor. When this occurs, the motor winding temperature will increase causing the motor to overheat and possibly cycle open the compressor overload protector. Continued overheating of the motor windings and/or cycling of the overload will eventually lead to compressor motor or overload failure.

Method Of Charging / Repairs

The acceptable method for charging the RAC system is the Weighed in Charge Method. The weighed in charge method is applicable to all units. It is the preferred method to use, as it is the most accurate.

The weighed in method should always be used whenever a charge is removed from a unit such as for a leak repair, compressor replacement, or when there is no refrigerant charge left in the unit. To charge by this method, requires the following steps:

1. Install a piercing valve to remove refrigerant from the sealed system. (Piercing valve must be removed from the system before recharging.)
2. Recover Refrigerant in accordance with EPA regulations.

⚠ WARNING	
	BURN HAZARD Proper safety procedures must be followed, and proper protective clothing must be worn when working with a torch. Failure to follow these procedures could result in moderate or serious injury.

3. Install a process tube to sealed system.

⚠ CAUTION	
	FREEZE HAZARD Proper safety procedures must be followed, and proper protective clothing must be worn when working with liquid refrigerant. Failure to follow these procedures could result in minor to moderate injury.

4. Make necessary repairs to system.
5. Evacuate system to 200 microns or less.
6. Weigh in refrigerant with the property quantity of R-22 refrigerant.
7. Start unit, and verify performance.

⚠ WARNING	
	BURN HAZARD Proper safety procedures must be followed, and proper protective clothing must be worn when working with a torch. Failure to follow these procedures could result in moderate or serious injury.

8. Crimp the process tube and solder the end shut.

⚠ WARNING



ELECTRIC SHOCK HAZARD

Turn off electric power before service or installation.

Extreme care must be used, if it becomes necessary to work on equipment with power applied.

Failure to do so could result in serious injury or death.

⚠ WARNING



HIGH PRESSURE HAZARD

Sealed Refrigeration System contains refrigerant and oil under high pressure.

Proper safety procedures must be followed, and proper protective clothing must be worn when working with refrigerants.

Failure to follow these procedures could result in serious injury or death.

Undercharged Refrigerant Systems

An undercharged system will result in poor performance (low pressures, etc.) in both the heating and cooling cycle.

Whenever you service a unit with an undercharge of refrigerant, always suspect a leak. The leak must be repaired before charging the unit.

To check for an undercharged system, turn the unit on, allow the compressor to run long enough to establish working pressures in the system (15 to 20 minutes).

During the cooling cycle you can listen carefully at the exit of the metering device into the evaporator; an intermittent hissing and gurgling sound indicates a low refrigerant charge. Intermittent frosting and thawing of the evaporator is another indication of a low charge, however, frosting and thawing can also be caused by insufficient air over the evaporator.

Checks for an undercharged system can be made at the compressor. If the compressor seems quieter than normal, it is an indication of a low refrigerant charge.

A check of the amperage drawn by the compressor motor should show a lower reading. (Check the Unit Specification.) After the unit has run 10 to 15 minutes, check the gauge pressures. Gauges connected to system with an undercharge will have low head pressures and substantially low suction pressures.

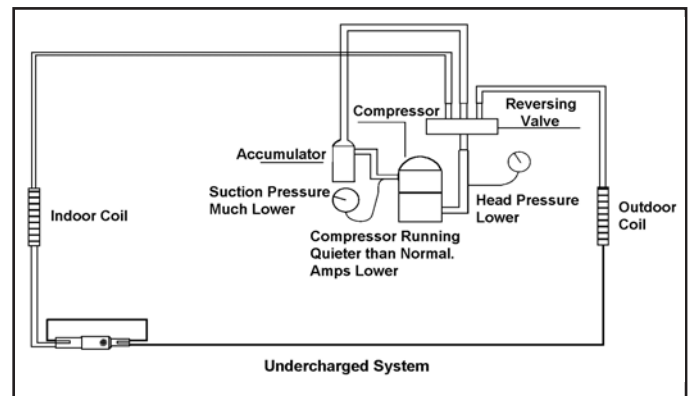

Overcharged Refrigerant Systems

Compressor amps will be near normal or higher. Noncondensables can also cause these symptoms. To confirm, remove some of the charge, if conditions improve, system may be overcharged. If conditions don't improve, Noncondensables are indicated.

Whenever an overcharged system is indicated, always make sure that the problem is not caused by air flow problems. Improper air flow over the evaporator coil may indicate some of the same symptoms as an over charged system.

An overcharge can cause the compressor to fail, since it would be "slugged" with liquid refrigerant.

The charge for any system is critical. When the compressor is noisy, suspect an overcharge, when you are sure that the air quantity over the evaporator coil is correct. Icing

of the evaporator will not be encountered because the refrigerant will boil later if at all. Gauges connected to system will usually have higher head pressure (depending upon amount of over charge). Suction pressure should be slightly higher.

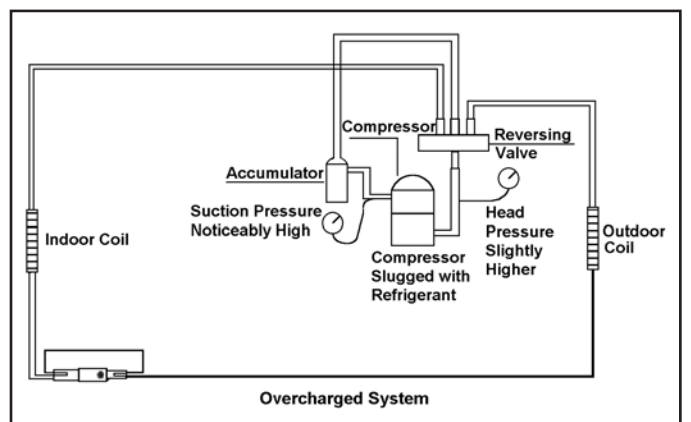

Restricted Refrigerant System

Troubleshooting a restricted refrigerant system can be difficult. The following procedures are the more common problems and solutions to these problems. There are two types of refrigerant restrictions: Partial restrictions and complete restrictions.

A partial restriction allows some of the refrigerant to circulate through the system.

With a complete restriction there is no circulation of refrigerant in the system.

Restricted refrigerant systems display the same symptoms as a "low-charge condition."

When the unit is shut off, the gauges may equalize very slowly.

Gauges connected to a completely restricted system will run in a deep vacuum. When the unit is shut off, the gauges will not equalize at all.

A quick check for either condition begins at the evaporator. With a partial restriction, there may be gurgling sounds

at the metering device entrance to the evaporator. The evaporator in a partial restriction could be partially frosted or have an ice ball close to the entrance of the metering device. Frost may continue on the suction line back to the compressor.

Often a partial restriction of any type can be found by feel, as there is a temperature difference from one side of the restriction to the other.

With a complete restriction, there will be no sound at the metering device entrance. An amperage check of the compressor with a partial restriction may show normal current when compared to the unit specification. With a complete restriction the current drawn may be considerably less than normal, as the compressor is running in a deep vacuum (no load.) Much of the area of the condenser will be relatively cool since most or all of the liquid refrigerant will be stored there.

The following conditions are based primarily on a system in the cooling mode.

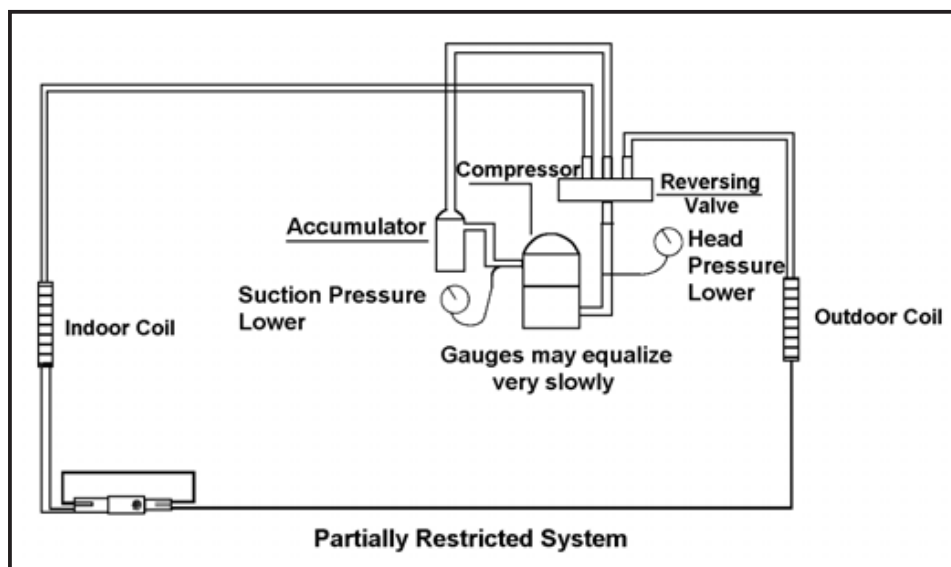
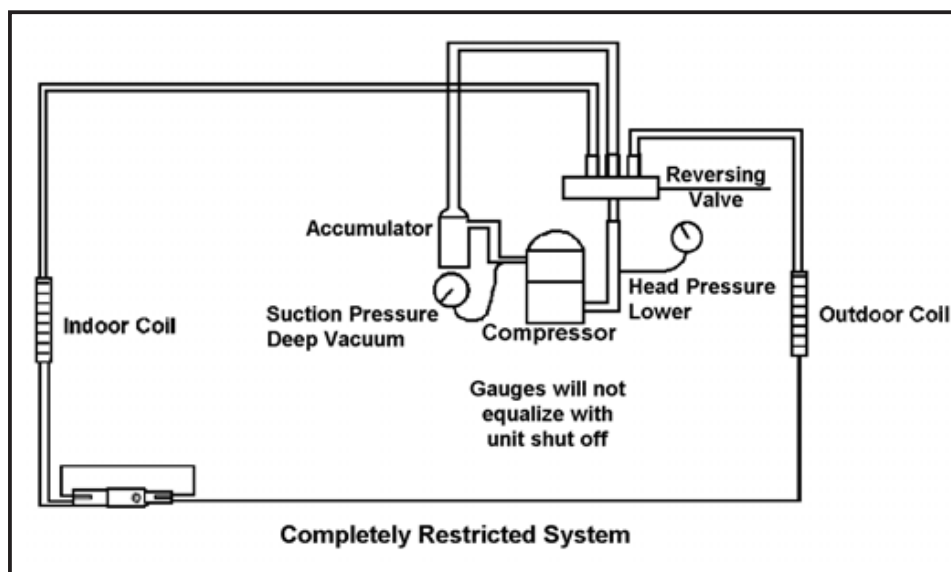

METERING DEVICE



Capillary Tube Systems

All units are equipped with capillary tube metering devices.

Checking for restricted capillary tubes.

1. Connect pressure gauges to unit.
2. Start the unit in the cooling mode. If after a few minutes of operation the pressures are normal, the check valve and the cooling capillary are not restricted.
3. Switch the unit to the heating mode and observe the gauge readings after a few minutes running time. If the system pressure is lower than normal, the heating capillary is restricted.
4. If the operating pressures are lower than normal in both the heating and cooling mode, the cooling capillary is restricted.

COMPRESSOR CHECKS

 WARNING	
	ELECTRIC SHOCK HAZARD Turn off electric power before service or installation. Extreme care must be used, if it becomes necessary to work on equipment with power applied. Failure to do so could result in serious injury or death.

Locked Rotor Voltage (L.R.V.) Test

Locked rotor voltage (L.R.V.) is the actual voltage available at the compressor under a stalled condition.

Single Phase Connections

Disconnect power from unit. Using a voltmeter, attach one lead of the meter to the run "R" terminal on the compressor and the other lead to the common "C" terminal of the compressor. Restore power to unit.

Determine L.R.V.

Start the compressor with the volt meter attached; then stop the unit. Attempt to restart the compressor within a couple of seconds and immediately read the voltage on the meter. The compressor under these conditions will not start and will usually kick out on overload within a few seconds since the pressures in the system will not have had time to equalize. Voltage should be at or above minimum voltage of 197 VAC, as specified on the rating plate. If less than minimum, check for cause of inadequate power supply; i.e., incorrect wire size, loose electrical connections, etc.

Amperage (L.R.A.) Test

The running amperage of the compressor is the most important of these readings. A running amperage higher than that indicated in the performance data indicates that a problem exists mechanically or electrically.

Single Phase Running and L.R.A. Test

NOTE: Consult the specification and performance section for running amperage. The L.R.A. can also be found on the rating plate.



Select the proper amperage scale and clamp the meter probe around the wire to the "C" terminal of the compressor. Turn on the unit and read the running amperage on the meter. If the compressor does not start, the reading will indicate the locked rotor amperage (L.R.A.).



External Overload

The compressor is equipped with an external overload which senses both motor amperage and winding temperature. High motor temperature or amperage heats the overload causing it to open, breaking the common circuit within the compressor.

Heat generated within the compressor shell, usually due to recycling of the motor, is slow to dissipate. It may take anywhere from a few minutes to several hours for the overload to reset.

Checking the External Overload

 WARNING	
	ELECTRIC SHOCK HAZARD Turn off electric power before service or installation. Extreme care must be used, if it becomes necessary to work on equipment with power applied. Failure to do so could result in serious injury or death.

 WARNING	
	BURN HAZARD Certain unit components operate at temperatures hot enough to cause burns. Proper safety procedures must be followed, and proper protective clothing must be worn. Failure to follow this warning could result in moderate to serious injury.

With power off, remove the leads from compressor terminals. If the compressor is hot, allow the overload to cool before starting check. Using an ohmmeter, test continuity across the terminals of the external overload. If you do not have continuity; this indicates that the overload is open and must be replaced.

⚠ WARNING



ELECTRIC SHOCK HAZARD

Disconnect power to the unit before servicing. Failure to follow this warning could result in serious injury or death.

INTERNAL OVERLOAD

Some model compressors are equipped with an internal overload. The overload is embedded in the motor windings to sense the winding temperature and/or current draw. The overload is connected in series with the common motor terminal.

Should the internal temperature and/or current draw become excessive, the contacts in the overload will open, turning off the compressor. The overload will automatically reset, but may require several hours before the heat is dissipated.

CHECKING THE INTERNAL OVERLOAD

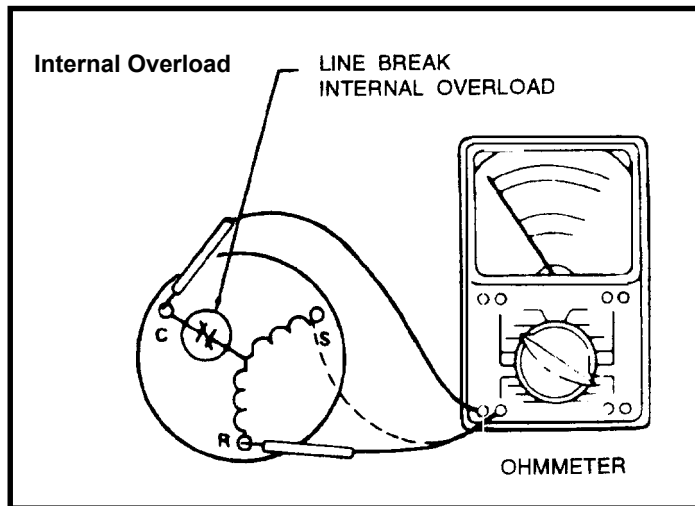

1. With no power to unit, remove the leads from the compressor terminals.
2. Using an ohmmeter, test continuity between terminals C-S and C-R. If no continuity, the compressor overload is open and the compressor must be replaced.

Single Phase Resistance Test

Remove the leads from the compressor terminals and set the ohmmeter on the lowest scale (R x 1).

Touch the leads of the ohmmeter from terminals common to start ("C" to "S"). Next, touch the leads of the ohmmeter from terminals common to run ("C" to "R").

Add values "C" to "S" and "C" to "R" together and check resistance from start to run terminals ("S" to "R"). Resistance "S" to "R" should equal the total of "C" to "S" and "C" to "R."

In a single phase PSC compressor motor, the highest value will be from the start to the run connections ("S"

to "R"). The next highest resistance is from the start to the common connections ("S" to "C"). The lowest resistance is from the run to common. ("C" to "R") Before replacing a compressor, check to be sure it is defective.

GROUND TEST

Use an ohmmeter set on its highest scale. Touch one lead to the compressor body (clean point of contact as a good connection is a must) and the other probe in turn to each compressor terminal. If a reading is obtained the compressor is grounded and must be replaced.

Check the complete electrical system to the compressor and compressor internal electrical system, check to be certain that compressor is not out on internal overload.

Complete evaluation of the system must be made whenever you suspect the compressor is defective. If the compressor has been operating for sometime, a careful examination must be made to determine why the compressor failed.

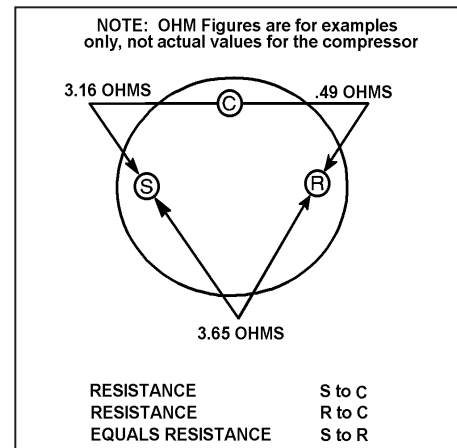

Many compressor failures are caused by the following conditions:

1. Improper air flow over the evaporator.
2. Overcharged refrigerant system causing liquid to be returned to the compressor.
3. Restricted refrigerant system.
4. Lack of lubrication.
5. Liquid refrigerant returning to compressor causing oil to be washed out of bearings.
6. Noncondensables such as air and moisture in the system. Moisture is extremely destructive to a refrigerant system.

CAPACITORS

⚠ WARNING



ELECTRIC SHOCK HAZARD

Turn off electric power before servicing.
Discharge capacitor with a 20,000 Ohm 2 Watt resistor before handling.

Failure to do so may result in personal injury, or death.

Many motor capacitors are internally fused. Shorting the terminals will blow the fuse, ruining the capacitor. A 20,000 ohm 2 watt resistor can be used to discharge capacitors safely. Remove wires from capacitor and place resistor across terminals. When checking a dual capacitor with a capacitor analyzer or ohmmeter, both sides must be tested.

Capacitor Check with Capacitor Analyzer

The capacitor analyzer will show whether the capacitor is “open” or “shorted.” It will tell whether the capacitor is within its micro farads rating and it will show whether the capacitor is operating at the proper power-factor percentage. The instrument will automatically discharge the capacitor when the test switch is released.

Capacitor Connections

The starting winding of a motor can be damaged by a shorted and grounded running capacitor. This damage usually can be avoided by proper connection of the running capacitor terminals.

From the supply line on a typical 230 volt circuit, a 115 volt potential exists from the “R” terminal to ground through a possible short in the capacitor. However, from the “S” or start terminal, a much higher potential, possibly as high as 400 volts, exists because of the counter EMF generated in the start winding. Therefore, the possibility of capacitor failure is much greater when the identified terminal is connected to the “S” or start terminal. The identified terminal should always be connected to the supply line, or “R” terminal, never to the “S” terminal.

When connected properly, a shorted or grounded running capacitor will result in a direct short to ground from the “R” terminal and will blow the line fuse. The motor protector will protect the main winding from excessive temperature.

Dual Rated Run Capacitor Hook-up

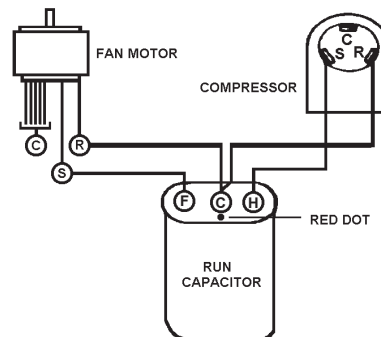

COMPRESSOR REPLACEMENT

Recommended procedure for compressor replacement

⚠ WARNING	
	RISK OF ELECTRIC SHOCK Unplug and/or disconnect all electrical power to the unit before performing inspections, maintenances or service. Failure to do so could result in electric shock, serious injury or death.

1. Be certain to perform all necessary electrical and refrigeration tests to be sure the compressor is actually defective before replacing.

⚠ WARNING	
	HIGH PRESSURE HAZARD Sealed Refrigeration System contains refrigerant and oil under high pressure. Proper safety procedures must be followed, and proper protective clothing must be worn when working with refrigerants. Failure to follow these procedures could result in serious injury or death.

2. Recover all refrigerant from the system though the process tubes. **PROPER HANDLING OF RECOVERED REFRIGERANT ACCORDING TO EPA REGULATIONS IS REQUIRED.** Do not use gauge manifold for this purpose if there has been a burnout. You will contaminate your manifold and hoses. Use a Schrader valve adapter and copper tubing for burnout failures.

⚠ WARNING	
	HIGH TEMPERATURES Extreme care, proper judgment and all safety procedures must be followed when testing, troubleshooting, handling or working around unit while in operation with high temperature components. Wear protective safety aids such as: gloves, clothing etc. Failure to do so could result in serious burn injury.

NOTICE	
FIRE HAZARD The use of a torch requires extreme care and proper judgment. Follow all safety recommended precautions and protect surrounding areas with fire proof materials. Have a fire extinguisher readily available. Failure to follow this notice could result in moderate to serious property damage.	

3. After all refrigerant has been recovered, disconnect suction and discharge lines from the compressor and remove compressor. Be certain to have both suction and discharge process tubes open to atmosphere.
4. Carefully pour a small amount of oil from the suction stub of the defective compressor into a clean container.
5. Using an acid test kit (one shot or conventional kit), test the oil for acid content according to the instructions with the kit.
6. If any evidence of a burnout is found, no matter how slight, the system will need to be cleaned up following proper procedures.
7. Install the replacement compressor.

⚠ WARNING	
	EXPLOSION HAZARD The use of nitrogen requires a pressure regulator. Follow all safety procedures and wear protective safety clothing etc. Failure to follow proper safety procedures result in serious injury or death.

8. Pressurize with a combination of R-22 and nitrogen and leak test all connections with an electronic or Halide leak detector. Recover refrigerant and repair any leaks found.

Repeat Step 8 to insure no more leaks are present.

9. Evacuate the system with a good vacuum pump capable of a final vacuum of 300 microns or less. The system should be evacuated through both liquid line and suction line gauge ports. While the unit is being evacuated, seal all openings on the defective compressor. Compressor manufacturers will void warranties on units received not properly sealed. Do not distort the manufacturers tube connections.

⚠ CAUTION	
	FREEZE HAZARD Proper safety procedures must be followed, and proper protective clothing must be worn when working with liquid refrigerant. Failure to follow these procedures could result in minor to moderate injury.

10. Recharge the system with the correct amount of refrigerant. The proper refrigerant charge will be found on the unit rating plate. The use of an accurate measuring device, such as a charging cylinder, electronic scales or similar device is necessary.

SPECIAL PROCEDURE IN THE CASE OF MOTOR COMPRESSOR BURNOUT

⚠ WARNING	
	<p>ELECTRIC SHOCK HAZARD Turn off electric power before service or installation.</p> <p>Failure to do so may result in personal injury, or death.</p>

⚠ WARNING	
	<p>HIGH PRESSURE HAZARD Sealed Refrigeration System contains refrigerant and oil under high pressure.</p> <p>Proper safety procedures must be followed, and proper protective clothing must be worn when working with refrigerants.</p> <p>Failure to follow these procedures could result in serious injury or death.</p>

⚠ WARNING	
	<p>EXPLOSION HAZARD The use of nitrogen requires a pressure regulator. Follow all safety procedures and wear protective safety clothing etc.</p> <p>Failure to follow proper safety procedures result in serious injury or death.</p>

1. Recover all refrigerant and oil from the system.
2. Remove compressor, capillary tube and filter drier from the system.
3. Flush evaporator condenser and all connecting tubing with dry nitrogen or equivalent. Use approved flushing agent to remove all contamination from system. Inspect suction and discharge line for carbon deposits. Remove and clean if necessary. Ensure all acid is neutralized.
4. Reassemble the system, including new drier strainer and capillary tube.
5. Proceed with step 9-10 above. (see page #22).

ROTARY COMPRESSOR SPECIAL TROUBLESHOOTING AND SERVICE

Basically, troubleshooting and servicing rotary compressors is the same as on the reciprocating compressor with only one main exception:

NEVER, under any circumstances, charge a rotary compressor through the **LOW** side. Doing so would cause permanent damage to the new compressor.

ROUTINE MAINTENANCE

⚠ WARNING



ELECTRIC SHOCK HAZARD

Turn off electric power before inspections, maintenances, or service.

Extreme care must be used, if it becomes necessary to work on equipment with power applied.

Failure to do so could result in serious injury or death.

NOTICE

Units are to be inspected and serviced by qualified service personnel only. Use proper protection on surrounding property. Failure to follow this notice could result in moderate or serious property damage.

AIR FILTER

Clean the unit air intake filter at least every 300 to 350 hours of operation. Clean the filters with a mild detergent in warm water and allow to dry thoroughly before reinstalling.

COILS AND BASE PAN

⚠ WARNING



EXCESSIVE WEIGHT HAZARD

Use two people to lift or carry the unit, and wear proper protective clothing.

Failure to do so may result in personal injury.

NOTICE

Do not use a caustic coil cleaning agent on coils or base pan. Use a biodegradable cleaning agent and degreaser, to prevent damage to the coil and/or base pan.

⚠ WARNING



CUT/SEVER HAZARD

Be careful with the sharp edges and corners. Wear protective clothing and gloves, etc.

Failure to do so could result in serious injury.

The indoor coil (evaporator coil), the outdoor coil (condenser coil) and base pan should be inspected periodically (yearly or bi-yearly) and cleaned of all debris (lint, dirt, leaves, paper, etc.). Clean the coils and base pan with a soft brush and compressed air or vacuum. If using a pressure washer, be careful not to bend the aluminium fin pack. Use a sweeping up and down motion in the direction of the vertical aluminum fin pack when pressure cleaning coils. Cover all electrical components to protect them from water or spray. Allow the unit to dry thoroughly before reinstalling it in the sleeve.

BLOWER WHEEL / HOUSING / CONDENSER FAN / SHROUD

Inspect the indoor blower housing, evaporator blade, condenser fan blade and condenser shroud periodically (yearly or bi-yearly) and clean of all debris (lint, dirt, mold, fungus, etc.). Clean the blower housing area and blower wheel with an antibacterial / antifungal cleaner. Use a biodegradable cleaning agent and degreaser on condenser fan and condenser shroud. Use warm or cold water when rinsing these items. Allow all items to dry thoroughly before reinstalling them.

ELECTRONIC / ELECTRICAL / MECHANICAL

Periodically (at least yearly or bi-yearly): inspect all control components: electronic, electrical and mechanical, as well as the power supply. Use proper testing instruments (voltmeter, ohmmeter, ammeter, wattmeter, etc.) to perform electrical tests. Use an air conditioning or refrigeration thermometer to check room, outdoor and coil operating temperatures. Use a sling psychrometer to measure wet bulb temperatures indoors and outdoors.

Inspect the surrounding area (inside and outside) to ensure that the unit's clearances have not been compromised or altered.

ROUTINE MAINTENANCE (Continued)

NOTICE

Do not drill holes in the bottom of the drain pan or the underside of the unit. Not following this notice could result in damage to the unit or condensate water leaking inappropriately which could cause water damage to surrounding property.

SLEEVE / DRAIN

Inspect the sleeve and drain system periodically (at least yearly or bi-yearly) and clean of all obstructions and debris. Clean both areas with an antibacterial and antifungal cleaner. Rinse both items thoroughly with water and ensure that the drain outlets are operating correctly. Check the sealant around the sleeve and reseal areas as needed.

FRONT COVER

Clean the front cover when needed. Use a mild detergent. Wash and rinse with warm water. Allow it to dry thoroughly before reinstalling it in the chassis.

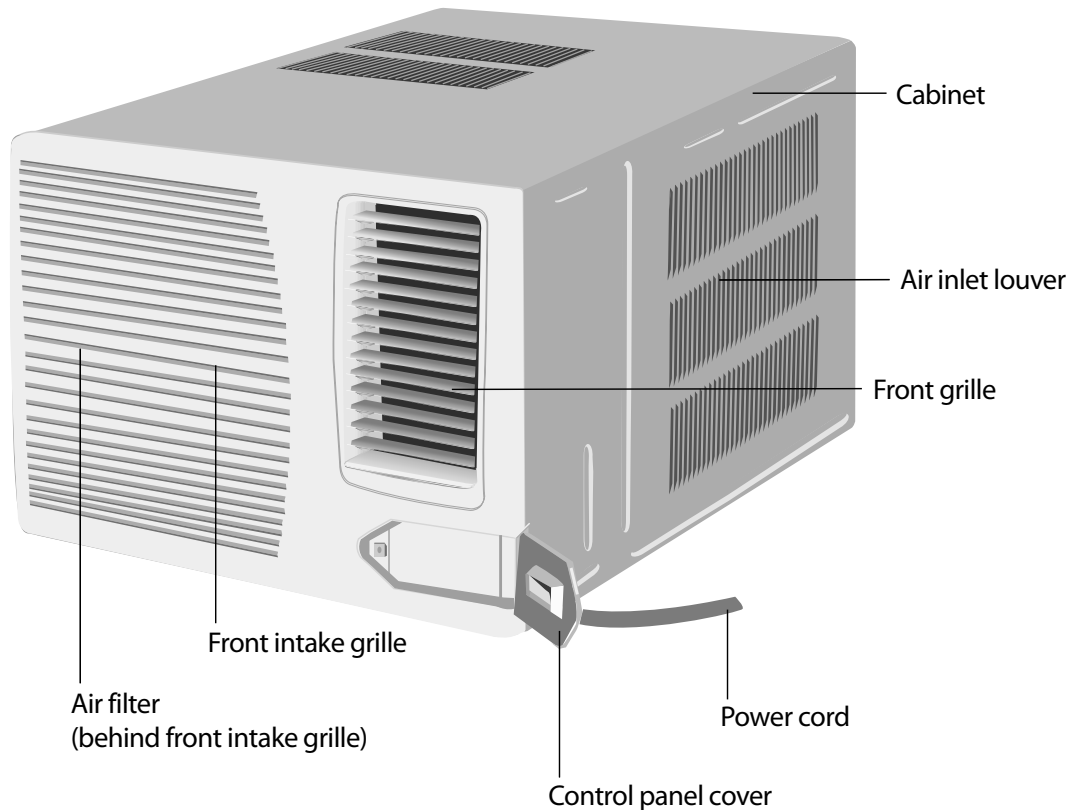

COOLING ONLY ROOM AIR CONDITIONERS: TROUBLESHOOTING TIPS

Problem	Possible Cause	Action
Compressor does not run	Low voltage	Check voltage at compressor. 115V & 230V units will operate at 10% voltage variance
	T-stat not set cold enough or inoperative	Set t-stat to coldest position. Test t-stat & replace if inoperative
	Compressor hums but cuts off on overload	Hard start compressor. Direct test compressor. If compressor starts, add starting components
	Open or shorted compressor windings	Check for continuity & resistance
	Open overload	Test overload protector & replace if inoperative
	Open capacitor	Test capacitor & replace if inoperative
	Inoperative system switch	Test for continuity in all positions. Replace if inoperative
	Broken, loose or incorrect wiring	Refer to appropriate wiring diagrams to check wiring

Problem	Possible Cause	Action
Fan motor does not run	Inoperative system switch	Test switch & replace if inoperative
	Broken, loose or incorrect wiring	Refer to applicable wiring diagram
	Open capacitor	Test capacitor & replace if inoperative
	Fan speed switch open	Test switch & replace if inoperative
	Inoperative fan motor	Test fan motor & replace if inoperative (be sure internal overload has had time to reset)

Problem	Possible Cause	Action
Does not cool or only cools slightly	Undersized unit	Refer to industry standard sizing chart
	T-stat open or inoperative	Set to coldest position. Test t-stat & replace if necessary
	Dirty filter	Clean as recommended in Owner's Manual
	Dirty or restricted condenser or evaporator coil	Use pressure wash or biodegradable cleaning agent to clean
	Poor air circulation	Adjust discharge louvers. Use high fan speed
	Fresh air or exhaust air door open on applicable models	Close doors. Instruct customer on use of this feature
	Low capacity - undercharge	Check for leak & make repair
	Compressor not pumping properly	Check amperage draw against nameplate. If not conclusive, make pressure test

COOLING ONLY ROOM AIR CONDITIONERS: TROUBLESHOOTING TIPS

Problem	Possible Cause	Action
Unit does not run	Fuse blown or circuit tripped	Replace fuse, reset breaker. If repeats, check fuse or breaker size. Check for shorts in unit wiring & components
	Power cord not plugged in	Plug it in
	System switch in "OFF" position	Set switch correctly
	Inoperative system switch or open control board	Test for continuity
	Loose or disconnected wiring at switch, control board or other components	Check wiring & connections. Reconnect per wiring diagram

Problem	Possible Cause	Action
Evaporator coil freezes up	Dirty filter	Clean as recommended in Owner's Manual
	Restricted airflow	Check for dirty or obstructed coil. Use pressure wash or biodegradable cleaning agent to clean
	Inoperative t-stat or thermistors	Test for continuity
	Short of refrigerant	De-ice coil & check for leak
	Inoperative fan motor	Test fan motor & replace if inoperative
	Partially restricted capillary tube	De-ice coil. Check temp. differential (delta T) across coil. Touch test coil return bends for same temp. Test for low running current

Problem	Possible Cause	Action
Compressor runs continually & does not cycle off	Excessive heat load	Unit undersized. Test cooling performance & replace with larger unit if needed
	Restriction in line	Check for partially iced coil & check temperature split across coil
	Refrigerant leak	Check for oil at silver soldered connections. Check for partially iced coil. Check split across coil. Check for low running amperage
	T-stat contacts stuck	Check operation of t-stat. Replace if contacts remain closed.
	T-stat incorrectly wired	Refer to appropriate wiring diagram
	Thermistor shorted	Replace thermistor or electronic control board

Problem	Possible Cause	Action
T-stat does not turn unit off	T-stat contacts stuck	Disconnect power to unit. Remove cover of t-stat & check if contacts are stuck. If so, replace t-stat
	T-stat set at coldest point	Turn to higher temp. setting to see if unit cycles off
	Incorrect wiring	Refer to appropriate wiring diagrams
	Unit undersized for area to be cooled	Refer to industry standard sizing chart
	Defective thermistor	Replace thermistor or electronic control board

COOLING ONLY ROOM AIR CONDITIONERS: TROUBLESHOOTING TIPS

Problem	Possible Cause	Action
Compressor runs for short periods only. Cycles on overload	Overload inoperative. Opens too soon	Check operation of unit. Replace overload if system operation is satisfactory
	Compressor restarted before system pressures equalized	Allow a minimum of 2 minutes to allow pressures to equalize before attempting to restart. Instruct customer of waiting period
	Low or fluctuating voltage	Check voltage with unit operating. Check for other appliances on circuit. Air conditioner should be in separate circuit for proper voltage & fused separately
	Incorrect wiring	Refer to appropriate wiring diagram
	Shorted or incorrect capacitor	Check by substituting a known good capacitor of correct rating
	Restricted or low air flow through condenser coil or evaporator coil	Check for proper fan speed or blocked coils
	Compressor running abnormally hot	Check for kinked discharge line or restricted condenser. Check amperage

Problem	Possible Cause	Action
T-stat does not turn unit on	Loss of charge in t-stat bulb	Place jumper across t-stat terminals to check if unit operates. If unit operates, replace t-stat.
	Loose or broken parts in t-stat	Check as above
	Incorrect wiring	Refer to appropriate wiring diagram
	Defective thermistor	Replace thermistor or electronic control board

Problem	Possible Cause	Action
Noisy operation	Poorly installed	Refer to Installation Manual for proper installation
	Fan blade striking chassis	Reposition - adjust motor mount
	Compressor vibrating	Check that compressor grommets have not deteriorated. Check that compressor mounting parts are not missing
	Improperly mounted or loose cabinet parts	Check assembly & parts for looseness, rubbing & rattling

Problem	Possible Cause	Action
Water leaks into the room	Evaporator drain pan overflowing	Clean obstructed drain trough
	Condensation forming on base pan	Evaporator drain pan broken or cracked. Reseal or replace. No chassis gasket installed. Install chassis gasket
	Poor installation resulting in rain entering the room	Check installation instructions. Reseal as required
	Condensation on discharge grille louvers	Dirty evaporator coil. Use pressure wash or biodegradable cleaning agent to clean. Environmental phenomena: point supply louvers upward
	Chassis gasket not installed	Install gasket, per Installation manual
	Downward slope of unit is too steep inward	Refer to installation manual for proper installation

COOLING ONLY ROOM AIR CONDITIONERS: TROUBLESHOOTING TIPS

Problem	Possible Cause	Action
Water "spitting" into room	Sublimation: When unconditioned saturated, outside air mixes with conditioned air, condensation forms on the cooler surfaces	Ensure that foam gaskets are installed in between window panes & in between the unit & the sleeve. Also, ensure that fresh air/exhaust vents (on applicable models) are in the closed position & are in tact
	Downward pitch of installation is too steep towards back of unit	Follow installation instructions to ensure that downward pitch of installed unit is no less than 1/4" & no more than 3/8"
	Restricted coil or dirty filter	Clean & advise customer of periodic cleaning & maintenance needs of entire unit

Problem	Possible Cause	Action
Excessive moisture	Insufficient air circulation thru area to be air conditioned	Adjust louvers for best possible air circulation
	Oversized unit	Operate in "MoneySaver" position
	Inadequate vapor barrier in building structure, particularly floors	Advise customer

Problem	Possible Cause	Action
T-stat or thermistor short cycles	Defective thermistor	Replace thermistor or electronic control board
	T-stat differential too narrow	Replace t-stat
	Plenum gasket not sealing, allowing discharge air to short cycle t-stat	Check gasket. Reposition or replace as needed
	Restricted coil or dirty filter	Clean & advise customer of periodic cleaning & maintenance needs of entire unit

Problem	Possible Cause	Action
Prolonged off cycles (automatic operation)	Heat anticipator (resistor) wire disconnected at t-stat or system switch	Refer to appropriate wiring diagram
	Heat anticipator (resistor) shorted or open	Disconnect plus from outlet. Remove resistor from bracket. Insert plug & depress "COOL" & "FAN AUTOMATIC" buttons. Place t-stat to warmest setting. Feel resistor for temperature. If no heat, replace resistor
	Partial loss of charge in t-stat bulb causing a wide differential	Replace t-stat
	Defective thermistor	Replace thermistor or electronic control board

Problem	Possible Cause	Action
Outside water leaks	Evaporator drain pan cracked or obstructed	Repair, clean or replace as required
	Water in compressor area	Detach shroud from pan & coil. Clean & remove old sealer. Reseal, reinstall & check
	Obstructed condenser coil	Use pressure wash or biodegradable cleaning agent to clean
	Fan blade/slinger ring improperly positioned	Adjust fan blade to 1/2" of condenser coil fin pack

ELECTRONIC CONTROL WIRING DIAGRAM: 2009 MODEL

CP14E10 / CP18E30

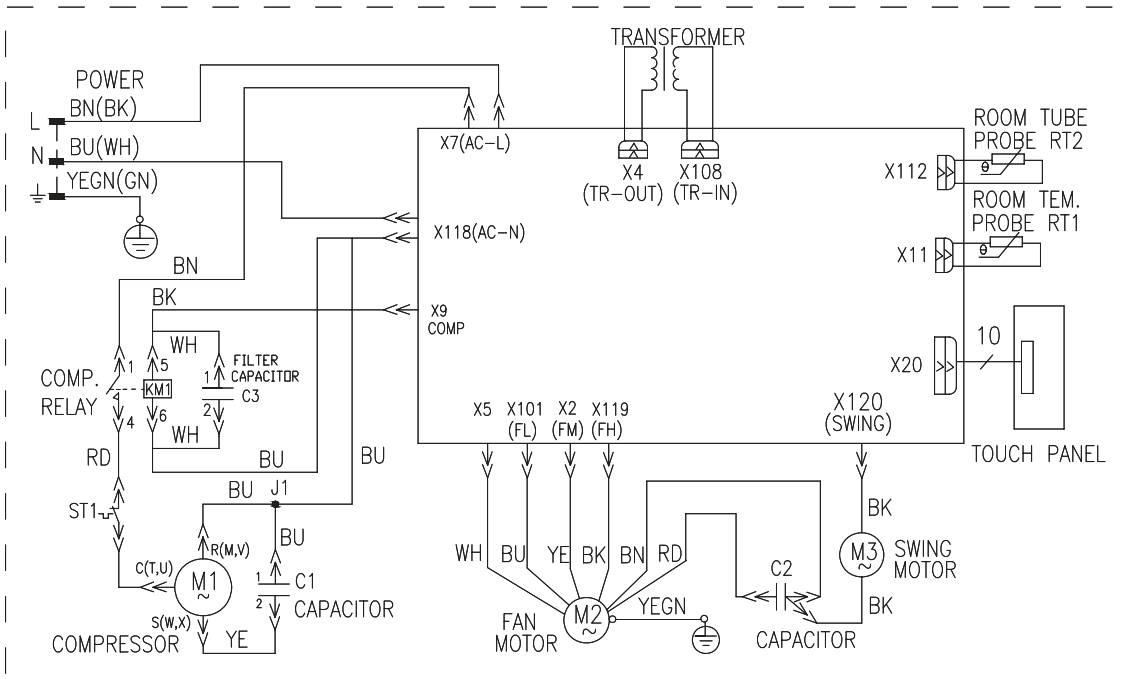

CP24E30

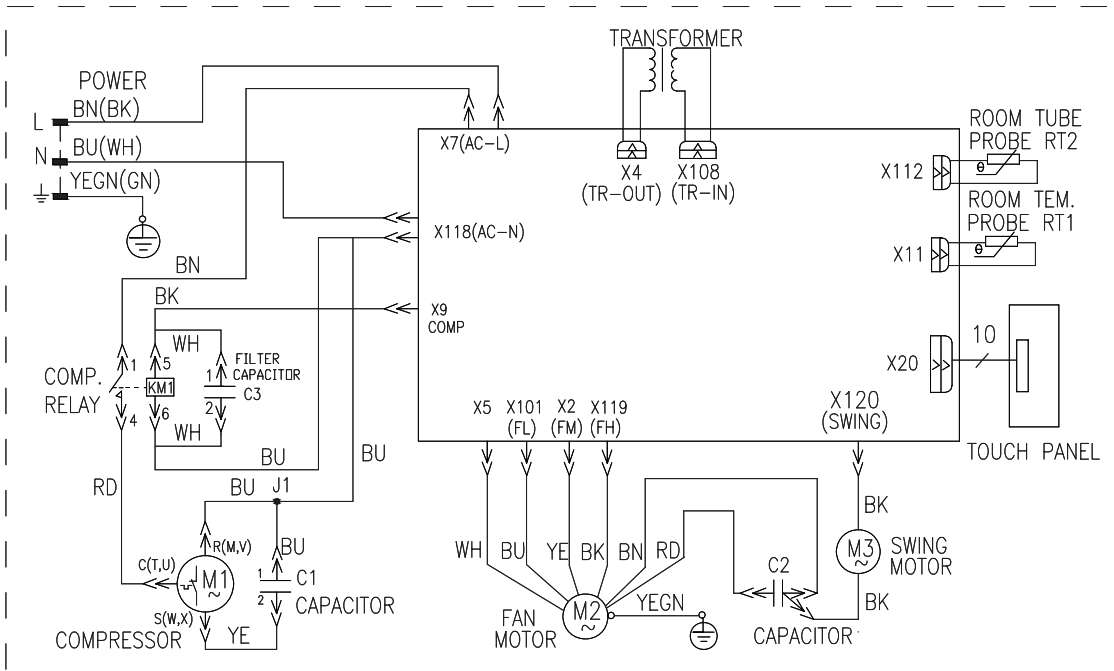

ELECTRONIC CONTROL WIRING DIAGRAM: 2008 MODEL

CP14N10 / CP18N30

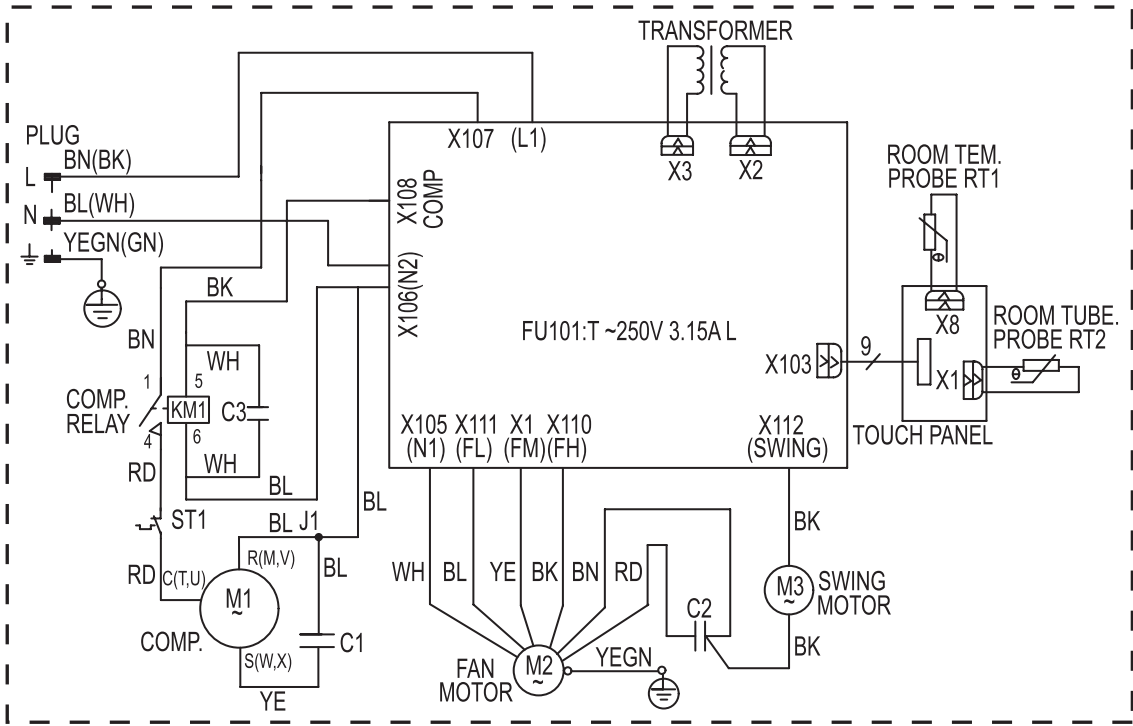

CP24N30

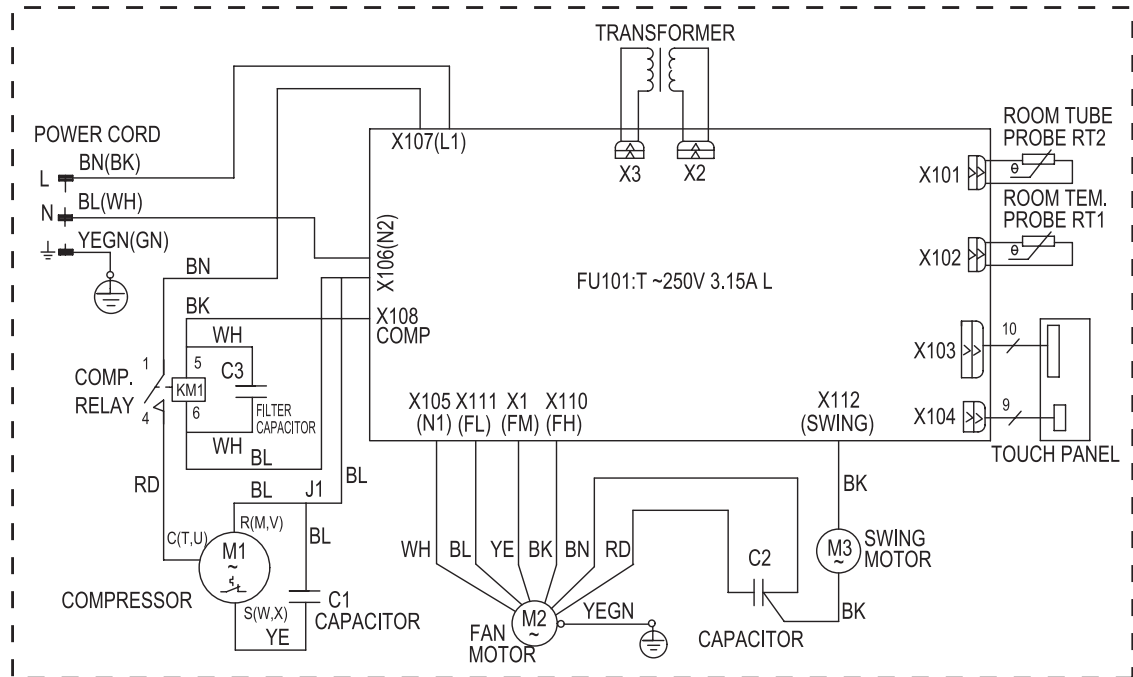

EXPLODED VIEW AND LIST OF PARTS

2009 MODEL: CP14E10, CP18E30 AND CP24E30

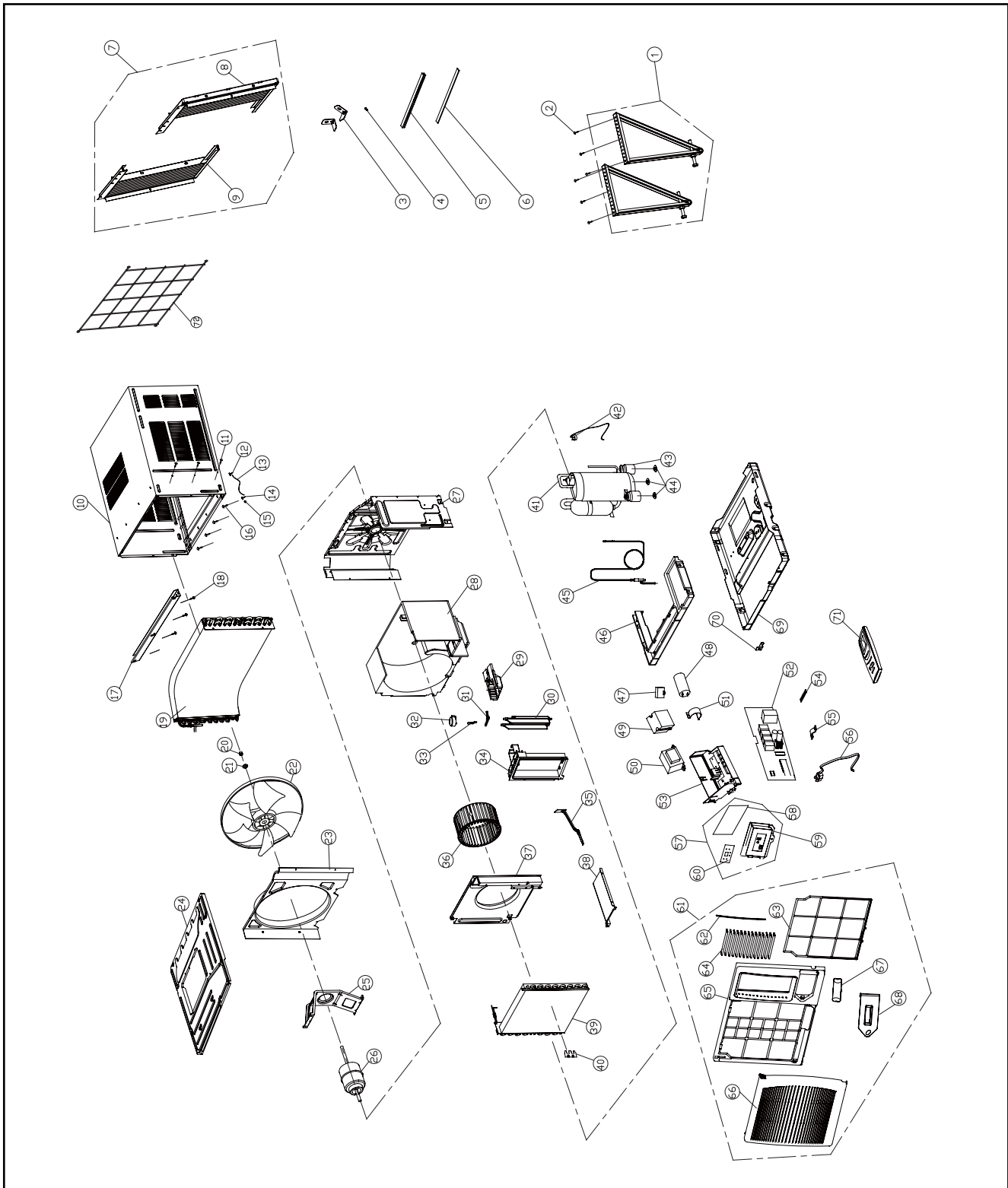

2009 PARTS

Model CP14E10

No	Description	Qty	Friedrich Part#
1	Supporter Assy	1	67700200
2	Screw ST4.2X13	7	67700154
3	Window locking bracket	2	67700113
4	Screw 4X20	6	67700151
5	Seal strip 1	1	67700128
6	Seal strip 2	1	67700129
7	Curtain Assemby Left and Right	1	67700201
8	Right Curtain	1	67700202
9	Left Curtain	1	67700203
10	Cabinet Assy	1	67700204
11	Screw ST4.2X6.5	6	67700155
12	Screw M4X8	1	67700149
13	Connect cord	1	67700170
14	Screw M4X5	1	67700205
15	Washer 4	1	67700158
16	Screw ST4.2X22	4	67700153
17	Top Rail Assy	1	67700206
18	Screw ST4X10	4	67700152
19	Condenser Assy	1	67700281
20	Nut with Washer M10	1	67700157
21	Washer 10	1	67700159
22	Fan Blade	1	67700117
23	Shroud, Fan Blade	1	67700208
24	Top Cover	1	67700110
25	Motor Support	1	67700112
26	Motor CJ100U	1	67700209
27	Innerwall	1	67700109
28	Shroud	1	67700127
29	Air Outlet Foam	1	67700130
30	Swing Louver	2	67700210
31	Swing Linkage	2	67700124
32	Motor, Swing Louver	1	67700211
33	Inflectional Axis	1	67700121
34	Swing Support	1	67700125
35	Fresh Air Door	1	67700212
36	Blower Wheel	1	67700116
37	Orifice (clapboard)	1	67700108
38	Base Plate of Air Flue	1	67700106
39	Evaporator Assy	1	67700103
40	Sensor Holder	1	67700213
41	Compressor 44B124HXCEF	1	67700282
42	Overload Protector	1	67700283
43	Compressor Gasket	3	67700284
44	Nut with washer M8	3	67700156
45	Capillary Assy	1	67700217
46	Water Tray	1	67700131
47	Capacitor 15uF/300VAC	1	67700218
48	Capacitor 50uF/450V	1	67700270
49	Relay 841-S-1A-D 110/120V	1	67700220
50	Transformer 41X26.5C	1	67700221
51	Capacitor clamp	1	67700114
52	Electronic Control Kit	1	67700259
53	Electric box	1	67700136
54	Isolation Washer D	1	67700223
55	Wire Clamp	1	67700160
56	Power cord	1	67700224
57	Receiver Cover	1	67700225
58	Membrane	1	67700226
59	Control Panel Cover A	1	67700227
60	Electronic Control Kit	1	67700259
61	Front Panel Assy	1	67700229
62	Guide Louver Linkage	1	67700230
63	Filter	1	67700231
64	Guide Louver	14	67700232
65	Front Case	1	67700233
66	Front Panel	1	67700234
67	AS Window Panel	1	67700235
68	Remote Cover Panel	1	67700236
69	Basepan (chassis)	1	67700237
70	Chassis Fixer	1	67700105
71	Remote Control	1	67700171

Model CP18E30

No	Description	Qty	Friedrich Part#
1	Supporter Assy	1	67700132
2	Self-threading Screw ST4.2x22	7	67700154
3	Window Locking Bracket	2	67700113
4	Screw 4X20	6	67700151
5	Seal Strip 1	1	67700128
6	Seal Strip 2	1	67700129
7	Curtain Assemby Left and Right	1	67700166
8	Right Curtain	1	67700168
9	Left Curtain	1	67700167
10	Cabinet Assy	1	67700271
11	Self-threading Screw ST4.2X6.5	6	67700155
12	Screw Assay M4x8	1	67700149
13	Connect Cord	1	67700170
14	Screw M4X6	1	67700150
15	Washer 4	1	67700158
16	Self-threading Screw ST4.2x22	6	67700153
17	Top Rail	1	67700134
18	Self-threading Screw with Gasket	4	67700152
19	Condenser Assy	1	67700272
20	Nut with Washer M10	1	67700157
21	Washer 6	1	67700159
22	Fan Blade	1	67700117
23	Shroud, Fan Blade	1	67700273
24	Top Cover (Upper Clapboard)	1	67700110
25	Motor Support	1	67700112
26	Motor CJ100B	1	67700241
27	Innerwall	1	67700109
28	Blower Front	1	67700127
29	Air Outlet Foam 1	1	67700130
30	Swing Louver	2	67700120
31	Lever of Vertical Guider	2	67700124
32	Swing Motor SM020B	1	67700133
33	Inflectional Axis	1	67700121
34	Cross Beam	1	67700125
35	Fresh Air Door	1	67700123
36	Blower Wheel	1	67700274
37	Orifice (clapboard)	1	67700108
38	Base Plate of Air Flue	1	67700106
39	Evaporator Assy	1	67700103
40	Insert Block	2	67700141
41	Compressor 2K25S236AHF	1	67700275
42	Overload Protector	1	67700276
43	Compressor Gasket AD7070815	3	67700277
44	Nut with Washer M8	3	67700156
45	Capillary Assay	1	67700278
46	Water Tray	1	67700131
47	Capacitor 7uF/450V	1	67700145
48	Capacitor CBB65 40uF/450V(TUV)	1	67700279
49	Relay 841-S-1A-D 200V/240V TU	1	67700147
50	Power Transformer 41X26.5F	1	67700146
51	Capacitor Clamp	1	67700114
52	Electronic Control Kit	1	67700260
53	Electric box	1	67700136
54	Isolation Washer D	1	67700223
55	Fixed Clamp	1	67700160
56	Power cord	1	67700169
57	Receiver Cover	1	67700138
58	Membrane	1	67700148
59	Control Panel Cover	1	67700137
60	Electronic Control Kit	1	67700260
61	Front Panel Assy	1	67700229
62	Guide louver linkage	1	67700122
63	Filter	1	67700231
64	Guide louver	8	67700118
65	Up Filter Guide	1	67700140
66	Front Panel (Down Filter Guide)	1	67700139
67	AS Window Panel	1	67700135
69	Basepan	1	67700280
70	Chassis Fixer	1	67700105
71	Remote Control	1	67700171

2009 PARTS (Continued)

Model CP24E30

No	Description	Qty	Friedrich Part#
1	Supporter Assy	1	67700200
2	Screw ST4.2X13	7	67700154
3	Window locking bracket	2	67700113
4	Screw 4X20	6	67700151
5	Seal strip 1	1	67700128
6	Seal strip 2	1	67700129
7	LT & RT Curtain Assembly	1	67700201
8	Right Curtain	1	67700202
9	Left Curtain	1	67700203
10	Cabinet Assy	1	67700238
11	Screw ST4.2X6.5	6	67700155
12	Screw M4X8	1	67700149
13	Connect cord	1	67700170
14	Screw M4X5	1	67700205
15	Washer 4	1	67700158
16	Screw ST4.2X22	4	67700153
17	Top Rail Assy	1	67700206
18	Screw ST4X10	4	67700152
19	Condenser Assy	1	67700239
20	Nut with Washer M10	1	67700157
21	Washer 10	1	67700159
22	Fan Blade	1	67700117
23	Shroud, Fan Blade	1	67700208
24	Top Cover	1	67700240
25	Motor Support	1	67700112
26	Motor CJ100U	1	67700265
27	Innerwall	1	67700109
28	Shroud	1	67700242
29	Air Outlet Foam	1	67700130
30	Swing Louver	2	67700210
31	Swing Linkage	2	67700124
32	Motor, Swing Louver	1	67700133
33	Inflectional Axis	1	67700121
34	Swing Support	1	67700125
35	Fresh Air Door	1	67700212
36	Blower Wheel	1	67700243
37	Orifice (clapboard)	1	67700108
38	Base Plate of Air Flue	1	67700106
39	Evaporator Assy	1	67700266
40	Sensor Holder	1	67700213
41	Compressor 44B124HXCEF	1	67700267
42	Overload Protector	1	67700283
43	Compressor Gasket	3	67700268
44	Nut with washer M8	3	67700156
45	Capillary Assy	1	67700269
46	Water Tray	1	67700131
47	Capacitor 15uF/300VAC	1	67700145
48	Capacitor 50uF/450V	1	67700270
49	Relay 841-S-1A-D 110/120V	1	67700147
50	Transformer 41X26.5C	1	67700247
51	Capacitor clamp	1	67700114
52	Electronic Control Kit	1	67700261
53	Electric box	1	67700136
54	Isolation Washer D	1	67700223
55	Wire Clamp	1	67700160
56	Power cord	1	67700249
57	Receiver Cover	1	67700225
58	Membrane	1	67700226
59	Control Panel Cover A	1	67700227
60	Electronic Control Kit	1	67700261
61	Front Panel Assy	1	67700229
62	Guide Louver Linkage	1	67700230
63	Filter	1	67700231
64	Guide Louver	14	67700232
65	Front Case	1	67700233
66	Front Panel	1	67700234
67	AS Window	1	67700235
68	Remote Cover Panel	1	67700236
69	Basepan (chassis)	1	67700250
70	Chassis Fixer	1	67700105
71	Remote Control	1	67700171

EXPLODED VIEW AND LIST OF PARTS

2008 MODEL: CP14N10, CP18N30 AND CP24N30

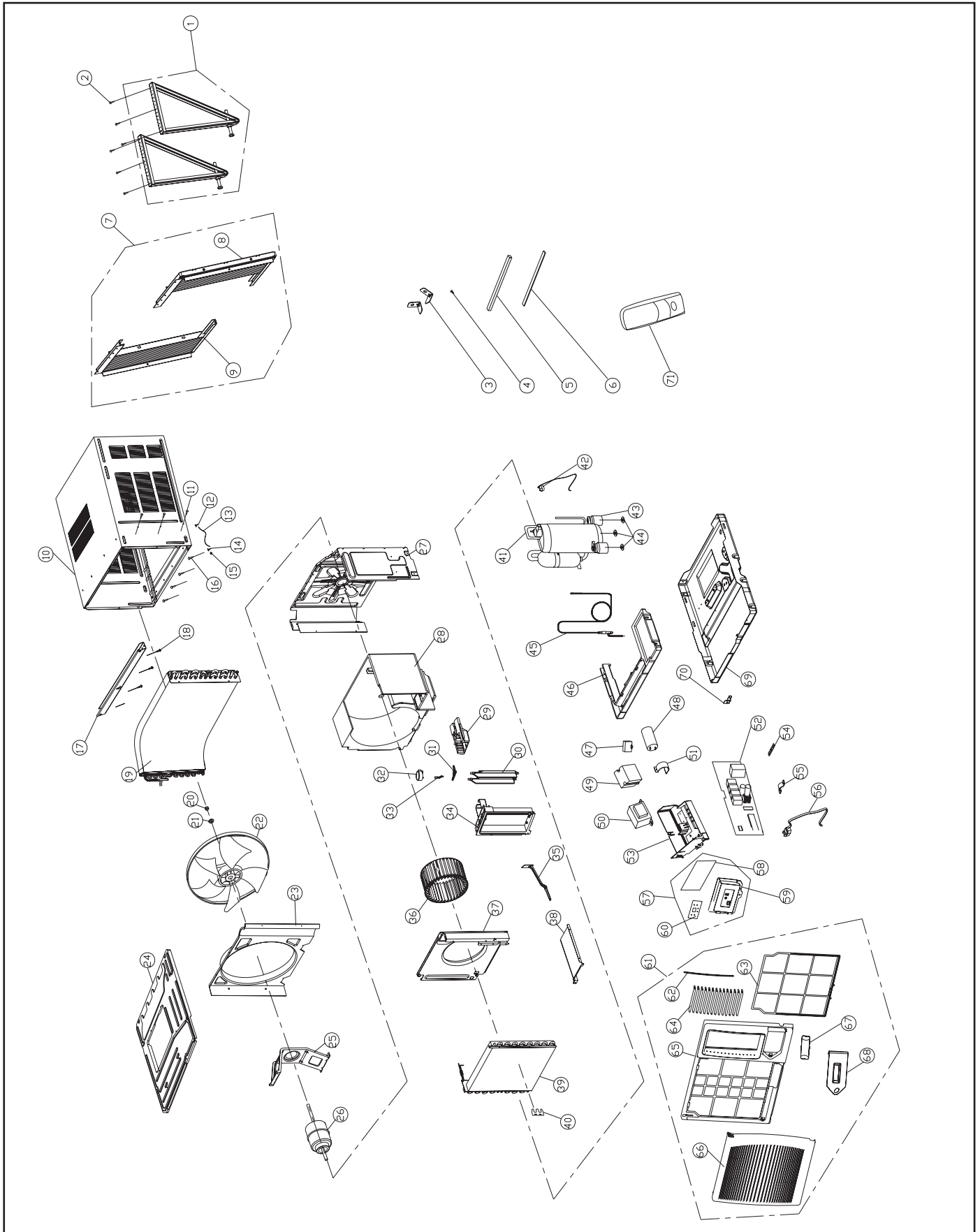

2008 PARTS

Model CP14N10

No	Description	Qty	Friedrich Part#
1	Supporter Assy	1	67700200
2	Screw ST4.2X13	7	67700154
3	Window locking bracket	2	67700113
4	Screw 4X20	6	67700151
5	Seal strip 1	1	67700128
6	Seal strip 2	1	67700129
7	Curtain Assembly Left and Right	1	67700201
8	Right Curtain	1	67700202
9	Left Curtain	1	67700203
10	Cabinet Assy	1	67700204
11	Screw ST4.2X6.5	6	67700155
12	Screw M4X8	1	67700149
13	Connect cord	1	67700170
14	Screw M4X5	1	67700205
15	Washer 4	1	67700158
16	Screw ST4.2X22	4	67700153
17	Top Rail Assy	1	67700206
18	Screw ST4X10	4	67700152
19	Condenser Assy	1	67700207
20	Nut with Washer M10	1	67700157
21	Washer 10	1	67700159
22	Fan Blade	1	67700117
23	Shroud, Fan Blade	1	67700208
24	Top Cover	1	67700110
25	Motor Support	1	67700112
26	Motor CJ100U	1	67700209
27	Innerwall	1	67700109
28	Shroud	1	67700127
29	Air Outlet Foam	1	67700130
30	Swing Louver	2	67700210
31	Swing Linkage	2	67700124
32	Motor, Swing Louver	1	67700211
33	Inflectional Axis	1	67700121
34	Swing Support	1	67700125
35	Fresh Air Door	1	67700212
36	Blower Wheel	1	67700116
37	Clapboard of Snail Shell	1	67700108
38	Base Plate of Air Flue	1	67700106
39	Evaporator Assy	1	67700103
40	Sensor Holder	1	67700213
41	Compressor 44B124HXCEF	1	67700214
42	Overload Protector	1	67700215
43	Compressor Gasket	3	67700216
44	Nut with washer M8	3	67700156
45	Capillary Assy	1	67700217
46	Water Tray	1	67700131
47	Capacitor 15uF/300VAC	1	67700218
48	Capacitor 50uF/450V	1	67700219
49	Relay 841-S-1A-D 110/120V	1	67700220
50	Transformer 41X26.5C	1	67700221
51	Capacitor clamp	1	67700114
52	Main PCB M2A91J	1	67700222
53	Electric box	1	67700136
54	Isolation Washer D	1	67700223
55	Wire Clamp	1	67700160
56	Power cord	1	67700224
57	Receiver Cover	1	67700225
58	Membrane	1	67700226
59	Control Panel Cover A	1	67700227
60	Display Board 2A91J	1	67700228
61	Front Panel Assy	1	67700229
62	Guide Louver Linkage	1	67700230
63	Filter	1	67700231
64	Guide Louver	14	67700232
65	Front Case	1	67700233
66	Front Panel	1	67700234
67	AS Window	1	67700235
68	Remote Cover	1	67700236
69	Chassis	1	67700237
70	Chassis Fixer	1	67700105
71	Remote Control	1	67700171

Model CP18N30

No	Description	Qty	Friedrich Part#
1	Supporter Assy	1	67700132
2	Self-threading Screw ST4.2x22	7	67700154
3	Window Locking Bracket	2	67700113
4	Screw 4X20	6	67700151
5	Seal Strip 1	1	67700128
6	Seal Strip 2	1	67700129
7	Curtain Assembly Left and Right	1	67700166
8	Right Curtain	1	67700168
9	Left Curtain	1	67700167
10	Cabinet Assy	1	67700111
11	Self-threading Screw ST4.2X6.5	6	67700155
12	Screw Assay M4x8	1	67700149
13	Connect Cord	1	67700170
14	Screw M4X6	1	67700150
15	Washer 4	1	67700158
16	Self-threading Screw ST4.2x22	6	67700153
17	Top Rail	1	67700134
18	Self-threading Screw with Gasket ST4X10	4	67700152
19	Condenser Assy	1	67700104
20	Nut with Washer M10	1	67700157
21	Washer 6	1	67700159
22	Fan Blade	1	67700117
23	Shroud, Fan Blade	1	67700107
24	Upper Clapboard	1	67700110
25	Motor Support	1	67700112
26	Motor CJ100B	1	67700164
27	Innerwall	1	67700109
28	Blower Front	1	67700127
29	Air Outlet Foam 1	1	67700130
30	Swing Louver	2	67700120
31	Lever of Vertical Guider	2	67700124
32	Swing Motor SM020B	1	67700133
33	Inflectional Axis	1	67700121
34	Cross Beam	1	67700125
35	Fresh Air Door	1	67700123
36	Blower Wheel	1	67700116
37	Front Clapboard of Snail Shell	1	67700108
38	Base Plate of Air Flue	1	67700106
39	Evaporator Assy	1	67700103
40	Insert Block	2	67700141
41	Compressor 2K25S236AHF	1	67700101
42	Overload Protector	1	67700102
43	Compressor Gasket AD7070815	3	67700161
44	Nut with Washer M8	3	67700156
45	Capillary Assay	1	67700115
46	Water Tray	1	67700131
47	Capacitor 7uF/450V	1	67700145
48	Capacitor CBB65 40uF/450V(TUV)	1	67700144
49	Relay 841-S-1A-D 200V/240V TUV	1	67700147
50	Power Transformer 41X26.5F	1	67700146
51	Capacitor Clamp	1	67700114
52	Electric box	1	67700136
53	Main PCB J25713J	1	67700142
54	Fixed Clamp	1	67700160
55	Power cord	1	67700169
56	Display Board J25713J	1	67700143
57	Receiver Cover	1	67700138
58	Control Panel Cover	1	67700137
59	Touch Pad Plate	1	67700148
60	Front Panel Assy	1	67700165
61	Guide louver linkage	1	67700122
62	Filter	1	67700163
63	Horizontal air guider1	8	67700118
64	Horizontal air guider2	1	67700119
65	Up Filter Guide	1	67700140
66	Down Filter Guide	1	67700139
67	Panel	1	67700135
68	Basepan	1	67700126
69	Chassis Fixer	1	67700105
70	Drain Plug	1	67700162
71	Remote Control	1	67700171

2008 PARTS (Continued)

Model CP24N30

No	Description	Qty	Friedrich Part#
1	Supporter Assy	1	67700200
2	Screw ST4.2X13	7	67700154
3	Window locking bracket	2	67700113
4	Screw 4X20	6	67700151
5	Seal strip 1	1	67700128
6	Seal strip 2	1	67700129
7	LT & RT Curtain Assembly	1	67700201
8	Right Curtain	1	67700202
9	Left Curtain	1	67700203
10	Cabinet Assy	1	67700238
11	Screw ST4.2X6.5	6	67700155
12	Screw M4X8	1	67700149
13	Connect cord	1	67700170
14	Screw M4X5	1	67700205
15	Washer 4	1	67700158
16	Screw ST4.2X22	4	67700153
17	Top Rail Assy	1	67700206
18	Screw ST4X10	4	67700152
19	Condenser Assy	1	67700239
20	Nut with Washer M10	1	67700157
21	Washer 10	1	67700159
22	Fan Blade	1	67700117
23	Shroud, Fan Blade	1	67700208
24	Top Cover	1	67700240
25	Motor Support	1	67700112
26	Motor CJ100U	1	67700241
27	Innerwall	1	67700109
28	Shroud	1	67700242
29	Air Outlet Foam	1	67700130
30	Swing Louver	2	67700210
31	Swing Linkage	2	67700124
32	Motor, Swing Louver	1	67700133
33	Inflectional Axis	1	67700121
34	Swing Support	1	67700125
35	Fresh Air Door	1	67700212
36	Blower Wheel	1	67700243
37	Blower Front	1	67700108
38	Base Plate of Air Flue	1	67700106
39	Evaporator Assy	1	67700103
40	Sensor Holder	1	67700213
41	Compressor 44B124HXCEF	1	67700244
42	Overload Protector	1	67700215
43	Compressor Gasket	3	67700216
44	Nut with washer M8	3	67700156
45	Capillary Assy	1	67700245
46	Water Tray	1	67700131
47	Capacitor 15uF/300VAC	1	67700145
48	Capacitor 50uF/450V	1	67700246
49	Relay 841-S-1A-D 110/120V	1	67700147
50	Transformer 41X26.5C	1	67700247
51	Capacitor clamp	1	67700114
52	Main PCB M2A91J	1	67700248
53	Electric box	1	67700136
54	Isolation Washer D	1	67700223
55	Wire Clamp	1	67700160
56	Power cord	1	67700249
57	Receiver Cover	1	67700225
58	Touch Pad Plate	1	67700226
59	Control Panel Cover A	1	67700227
60	Display Board 2A91J	1	67700228
61	Front Panel Assy	1	67700229
62	Guide Louver Linkage	1	67700230
63	Filter	1	67700231
64	Guide Louver	14	67700232
65	Front Case	1	67700233
66	Front Panel	1	67700234
67	AS Window	1	67700235
68	Remote Cover	1	67700236
69	Basepan	1	67700250
70	Chassis Fixer	1	67700105
71	Remote Control	1	67700171



Friedrich Air Conditioning Company

P.O. Box 1540
San Antonio, TX 78295
210.357.4400
www.friedrich.com

ROOM AIR CONDITIONERS LIMITED WARRANTY

FIRST YEAR

ANY PART: If any part supplied by FRIEDRICH fails because of a defect in workmanship or material within twelve months from date of original purchase, FRIEDRICH will repair the product at no charge, provided room air conditioner is reasonably accessible for service. Any additional labor cost for removing inaccessible units and/or charges for mileage related to travel by a Service Agency that exceeds 25 miles one way will be the responsibility of the owner. This remedy is expressly agreed to be the exclusive remedy within twelve months from the date of the original purchase.

SECOND THROUGH FIFTH YEAR

SEALED REFRIGERANT SYSTEM: If the Sealed Refrigeration System (defined for this purpose as the compressor, condenser coil, evaporator coil, reversing valve, check valve, capillary, filter drier, and all interconnecting tubing) supplied by FRIEDRICH in your Room Air Conditioner fails because of a defect in workmanship or material within sixty months from date of purchase, FRIEDRICH will pay a labor allowance and parts necessary to repair the Sealed Refrigeration System; **PROVIDED** FRIEDRICH will not pay the cost of diagnosis of the problem, removal, freight charges, and transportation of the air conditioner to and from the Service Agency, and the reinstallation charges associated with repair of the Sealed Refrigeration System. All such cost will be the sole responsibility of the owner. This remedy is expressly agreed to be the exclusive remedy within sixty months from the date of the original purchase.

APPLICABILITY AND LIMITATIONS: This warranty is applicable only to units retained within the Fifty States of the U.S.A., District of Columbia, and Canada. This warranty is not applicable to:

1. Air filters or fuses.
2. Products on which the model and serial numbers have been removed.
3. Products which have defects or damage which results from improper installation, wiring, electrical current characteristics, or maintenance; or caused by accident, misuse or abuse, fire, flood, alterations and/or misapplication of the product and/or units installed in a corrosive atmosphere, default or delay in performance caused by war, government restrictions or restraints, strikes, material shortages beyond the control of FRIEDRICH, or acts of God.

OBTAINING WARRANTY PERFORMANCE: Service will be provided by the **FRIEDRICH Authorized Dealer or Service Organization** in your area. They are listed in the Yellow Pages. If assistance is required in obtaining warranty performance, write to: Room Air Conditioner Service Manager, Friedrich Air Conditioning Co., P.O. Box 1540, San Antonio, TX 78295-1540.

LIMITATIONS: THIS WARRANTY IS GIVEN IN LIEU OF ALL OTHER WARRANTIES. Anything in the warranty notwithstanding, ANY IMPLIED WARRANTIES OF FITNESS FOR PARTICULAR PURPOSE AND/OR MERCHANTABILITY SHALL BE LIMITED TO THE DURATION OF THIS EXPRESS WARRANTY. MANUFACTURER EXPRESSLY DISCLAIMS AND EXCLUDES ANY LIABILITY FOR CONSEQUENTIAL OR INCIDENTAL DAMAGE FOR BREACH OF ANY EXPRESSED OR IMPLIED WARRANTY.

Performance of Friedrich's Warranty obligation is limited to one of the following methods:

1. Repair of the unit
2. A refund to the customer for the prorated value of the unit based upon the remaining warranty period of the unit.
3. Providing a replacement unit of equal value

The method of fulfillment of the warranty obligation is at the sole discretion of Friedrich Air Conditioning.

NOTE: Some states do not allow limitations on how long an implied warranty lasts, or do not allow the limitation or exclusion of consequential or incidental damages, so the foregoing exclusions and limitations may not apply to you.

OTHER: This warranty gives you specific legal rights, and you may also have other rights which vary from state to state.

PROOF OF PURCHASE: Owner must provide proof of purchase in order to receive any warranty related services.

All service calls for explaining the operation of this product will be the sole responsibility of the consumer.

All warranty service must be provided by an **Authorized FRIEDRICH Service Agency**, unless authorized by FRIEDRICH prior to repairs being made.

(10-08)

TECHNICAL SUPPORT CONTACT INFORMATION



FRIEDRICH AIR CONDITIONING CO.

Post Office Box 1540 · San Antonio, Texas 78295-1540
4200 N. Pan Am Expressway · San Antonio, Texas 78218-5212
(210) 357-4400 · FAX (210) 357-4490
www.friedrich.com

Printed in the U.S.A.



FRIEDRICH AIR CONDITIONING CO.

Post Office Box 1540 · San Antonio, Texas 78295-1540
4200 N. Pan Am Expressway · San Antonio, Texas 78218-5212
(210) 357-4400 · FAX (210) 357-4490
www.friedrich.com

Printed in the U.S.A.

CP-14-18-24-ServMan (04-09)