

This Owner's Manual is provided and hosted by [Appliance Factory Parts](#).

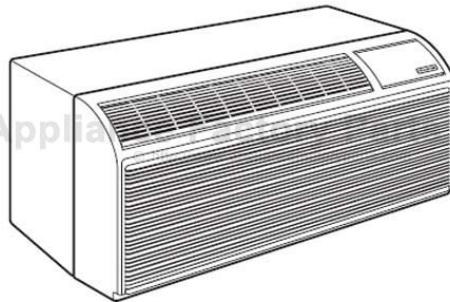

# FRIEDRICH PDH07R\*\*B-A Owner's Manual

[Shop genuine replacement parts for FRIEDRICH  
PDH07R\\*\\*B-A](#)



[Find Your FRIEDRICH Air Conditioner Parts - Select From 1575 Models](#)

----- Manual continues below -----

## Parts Manual

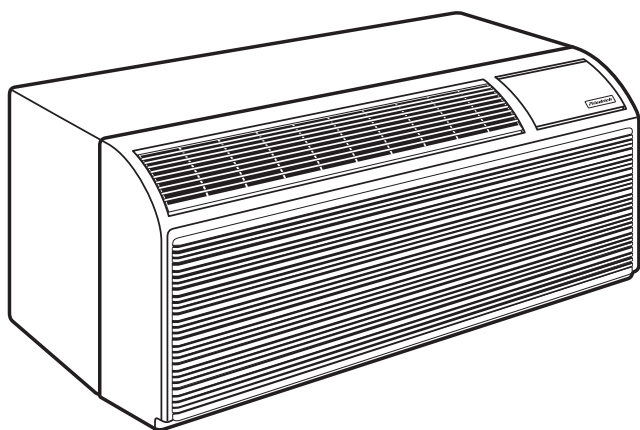

### **PTAC PD Series (Electronic Controls)**

**Packaged Terminal Air Conditioners**

**Packaged Terminal Heat Pumps**

**Serial Number LEAP and Later**

#### **MODELS**

---

<b>PDE07K**B-A</b>	<b>PDE12K**B-A</b>	<b>PDH07K**B-A</b>	<b>PDH12K**B-A</b>
<b>PDE07R**B-A</b>	<b>PDE12R**B-A</b>	<b>PDH07R**B-A</b>	<b>PDH12R**B-A</b>
<b>PDE09K**B-A</b>	<b>PDE15K**B-A</b>	<b>PDH09K**B-A</b>	<b>PDH15K**B-A</b>
<b>PDE09R**B-A</b>	<b>PDE15R**B-A</b>	<b>PDH09R**B-A</b>	<b>PDH15R**B-A</b>

# Table of Contents

PTAC Model Number Identification Guide.....	3
PTAC Serial Number Identification Guide .....	3
Unit Assembly.....	4
Unit Assembly Parts List.....	5
Air Handler .....	6
Air Handler Parts List .....	7
Control Box Assembly .....	8
Front Cover Assembly.....	10
Notes .....	11

# UNIT IDENTIFICATION

Model Number Code

## PD H 07 K 3 S B A

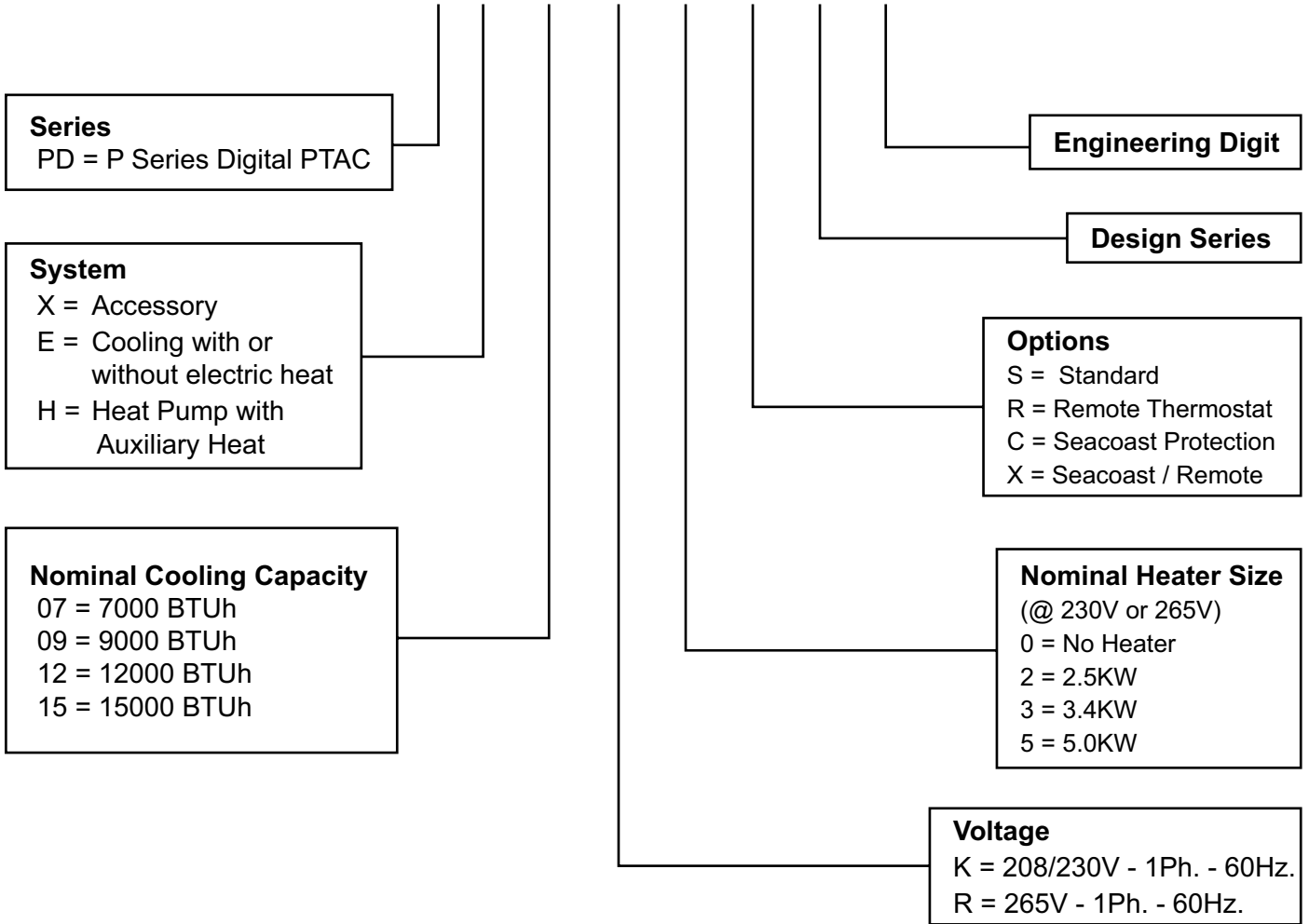

PTAC Serial Number Identification Guide					
<b>Serial Number</b>	L	E	A	P	00000 <b>Production Run Number</b>
<b>Decade Manufactured</b>	<b>Product Line</b>  R = RAC P = PTAC E = EAC V = VPAK H = DSS				
L = 0    C = 3    F = 6    J = 9 A = 1    D = 4    G = 7 B = 2    E = 5    H = 8					
<b>Year Manufactured</b>					
A = 1    C = 3    E = 5    G = 7    J = 9 B = 2    D = 4    F = 6    H = 8    K = 0					
<b>Month Manufactured</b>					
A = Jan    D = Apr    G = Jul    K = Oct B = Feb    E = May    H = Aug    L = Nov C = Mar    F = Jun    J = Sep    M = Dec					

# UNIT ASSEMBLY

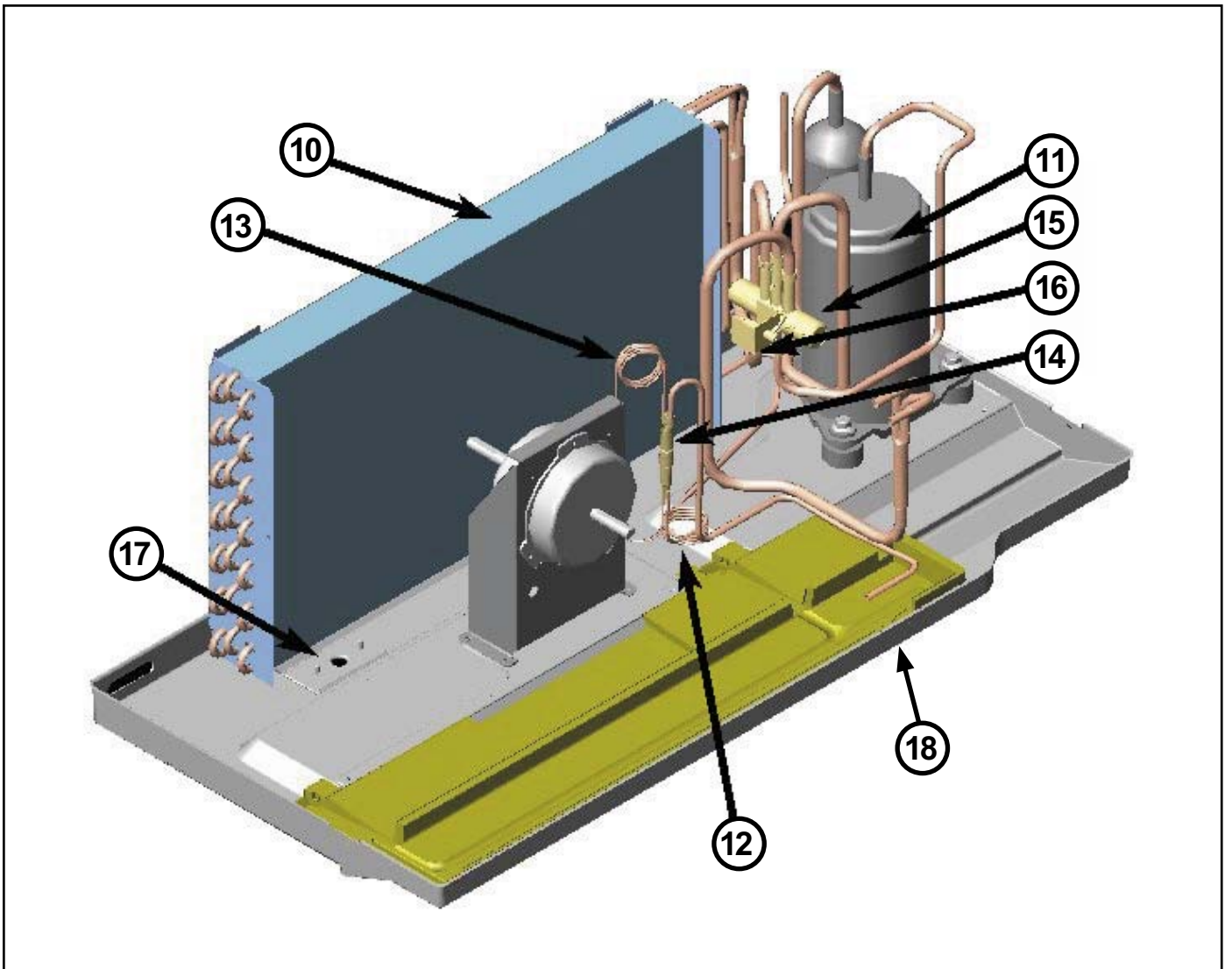

REF.	PART NO.	DESCRIPTION	07	09	12	15	NOTES
N/S	25059400	Coil, Indoor	1	1	1	-	
N/S	25065000	Coil, Indoor	-	-	-	1	
10	25014820	Coil, Outdoor	1	1	1	1	
10	25014821	Coil, Outdoor	1	1	1	1	Seacoast
10	25064800	Coil, Outdoor- Heat Pump Only	-	-	-	1	
10	25064801	Coil, Outdoor- Heat Pump Only	-	-	-	1	Seacoast
11	25024915	Compressor, 230 Volt	1	-	-	-	
11	25024908	Compressor, 230 Volt	-	1	-	-	
11	25024907	Compressor, 230 Volt	-	-	1	-	
11	25024910	Compressor, 230 Volt	-	-	-	1	
11	25024914	Compressor, 265 Volt	1	-	-	-	
11	25024913	Compressor, 265 Volt	-	1	-	-	
11	25024912	Compressor, 265 Volt	-	-	1	-	
11	25024911	Compressor, 265 Volt	-	-	-	1	
12	03760548	Cap Tube A/C-Electric Only	1	-	-	-	
12	03760547	Cap Tube A/C-Electric Only	-	1	-	-	
12	03760511	Cap Tube A/C-Electric Only	-	-	1	-	
12	01389985	Cap Tube A/C-Electric Only	-	-	-	1	
12	03760547	Cap Tube, Cooling, Heat Pump	1	-	-	-	
12	03760547	Cap Tube, Cooling, Heat Pump	-	1	-	-	
12	01390000	Cap Tube, Cooling, Heat Pump	-	-	1	-	
12	01389975	Cap Tube, Cooling, Heat Pump	-	-	-	1	
13	03760473	Cap Tube, Heating, Heat Pump	1	-	-	-	
13	03760547	Cap Tube, Heating, Heat Pump	-	1	-	-	
13	01389975	Cap Tube, Heating, Heat Pump	-	-	1	-	
13	01389985	Cap Tube, Heating, Heat Pump	-	-	-	1	
14	25057200	Check Valve	1	-	-	-	
14	25057201	Check Valve	-	1	1	1	
15	25022010	Reversing Valve Kit (Includes Solenoids)	1	1	-	-	
15	25022020	Reversing Valve Kit (Includes Solenoids)	-	-	1	1	
16	25022050	Solenoid Coil 230 Volt	1	1	1	1	
16	25022060	Solenoid Coil 265 Volt	1	1	1	1	
17	60179903	Condensate Valve (bellows type)	1	1	1	1	
18	25014502	Drain Pan	1	1	1	1	
N/S	61764537	Overload Compressor 230 Volt	1	-	-	-	
N/S	61764535	Overload Compressor 230 Volt	-	1	-	-	
N/S	61764521	Overload Compressor 230 Volt	-	-	1	-	
N/S	61764532	Overload Compressor 230 Volt	-	-	-	1	
N/S	61764543	Overload Compressor 265 Volt	1	-	-	-	
N/S	61764542	Overload Compressor 265 Volt	-	1	-	-	
N/S	61764541	Overload Compressor 265 Volt	-	-	1	-	
N/S	61764538	Overload Compressor 265 Volt	-	-	-	1	

# AIR HANDLER

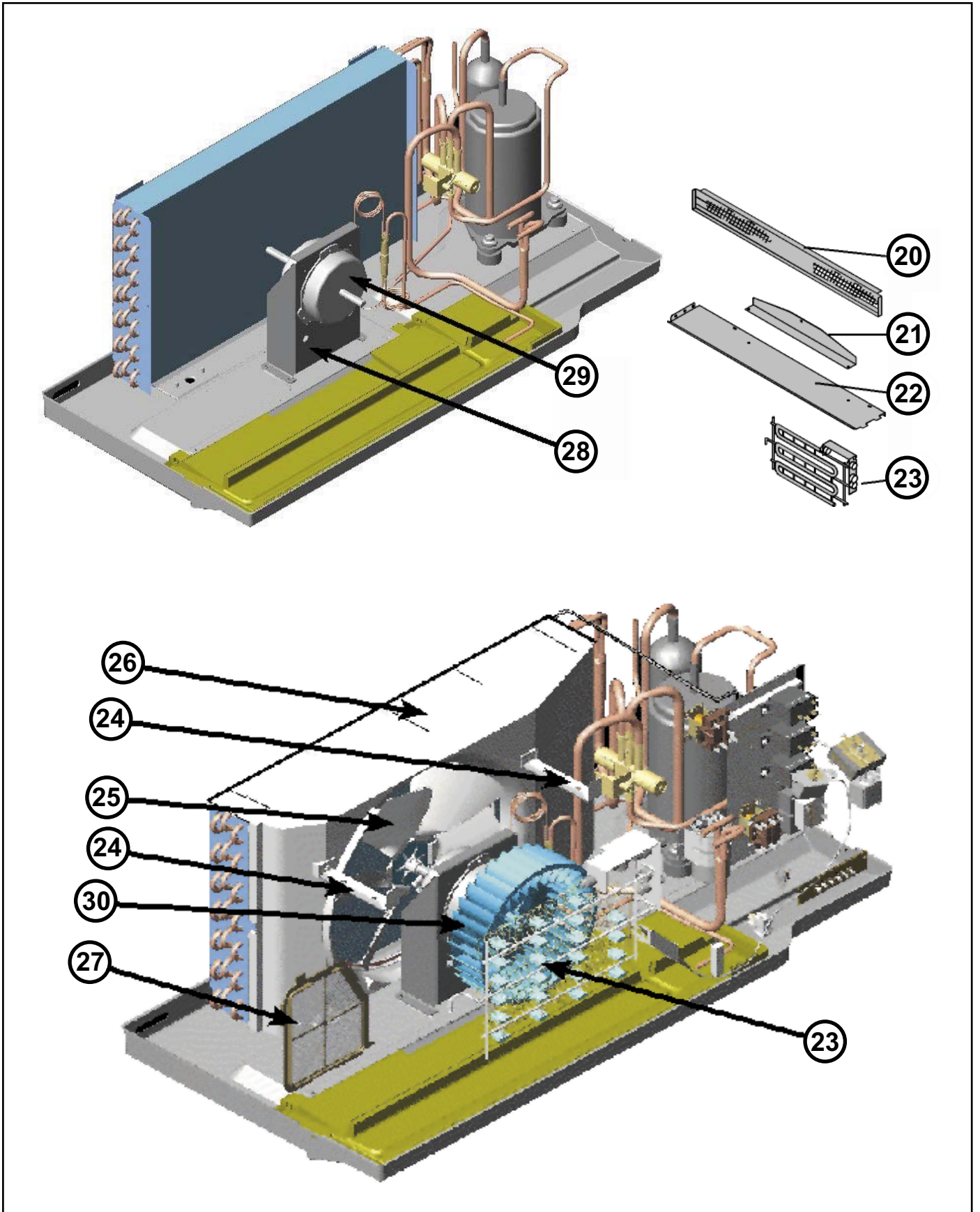

REF.	PART NO.	DESCRIPTION	07	09	12	15	NOTES
20	25038401	Discharge Screen	1	1	1	1	
21	25067500	Air Deflector	1	1	1	1	
22	25016011	Deck	1	1	1	1	
23	25059160	Heater, 2.5 kW @ 230 Volt	1	1	1	1	
23	25059161	Heater, 3.4 kW @ 230 Volt	1	1	1	1	
23	25059184	Heater, 5.0 kW @ 230 Volt	1	1	1	1	
23	25059162	Heater, 2.5 kW @ 265 Volt	1	1	1	1	
23	25059163	Heater, 3.4 kW @ 265 Volt	1	1	1	1	
23	25059185	Heater, 5.0 kW @ 265 Volt	1	1	1	1	
24	25036400	Support Brace (condenser)	1	1	1	1	
25	60542006	Condenser slinger blade	1	1	1	1	
26	25036801	Condenser Shroud	1	1	1	1	
27	25015300	Fresh Air Door Screen	1	1	1	1	
27	25034900	Fresh Air Door Insulation	1	1	1	1	
28	25014400	Motor Mount Bracket	1	1	1	1	
29	25014600	Motor, 230 Volt 1/15 HP 2P	1	1	–	–	
29	25014610	Motor, 230 Volt 1/10 HP 2P	–	–	1	1	
29	25014601	Motor, 265 Volt 1/15 HP 2P	1	1	–	–	
29	25014611	Motor, 265 Volt 1/10 HP 2P	–	–	1	1	
30	25069100	Blower Wheel 7-9	1	1	–	–	
30	25069000	Blower Wheel 12-15	–	–	1	1	
N/S	25014306	Scroll 7-9	1	1	–	–	
N/S	25014306	Scroll 12-15	–	–	1	1	
N/S	60217902	Seal, Motor to Wall	1	1	1	1	
N/S	25015900	Fresh Air Door Latch	1	1	1	1	
N/S	25045100	Fresh Air Door Cable	1	1	1	1	
N/S	25059620	Primary Limit Switch 145°F 2.5-3.4 kW	1	1	1	1	
N/S	25059621	Primary Limit Switch 155°F 5 kW	–	–	1	1	
N/S	25059618	Secondary Limit Switch 200°F	1	1	1	1	
N/S	61828200	Suction Dryer	1	1	1	1	
N/S	60308101	Liquid line Dryer (not for heat pump)	1	1	1	1	Cooling Only
N/S	25065700	Jumper, Heater	1	1	1	1	

# CONTROL BOX ASSEMBLY

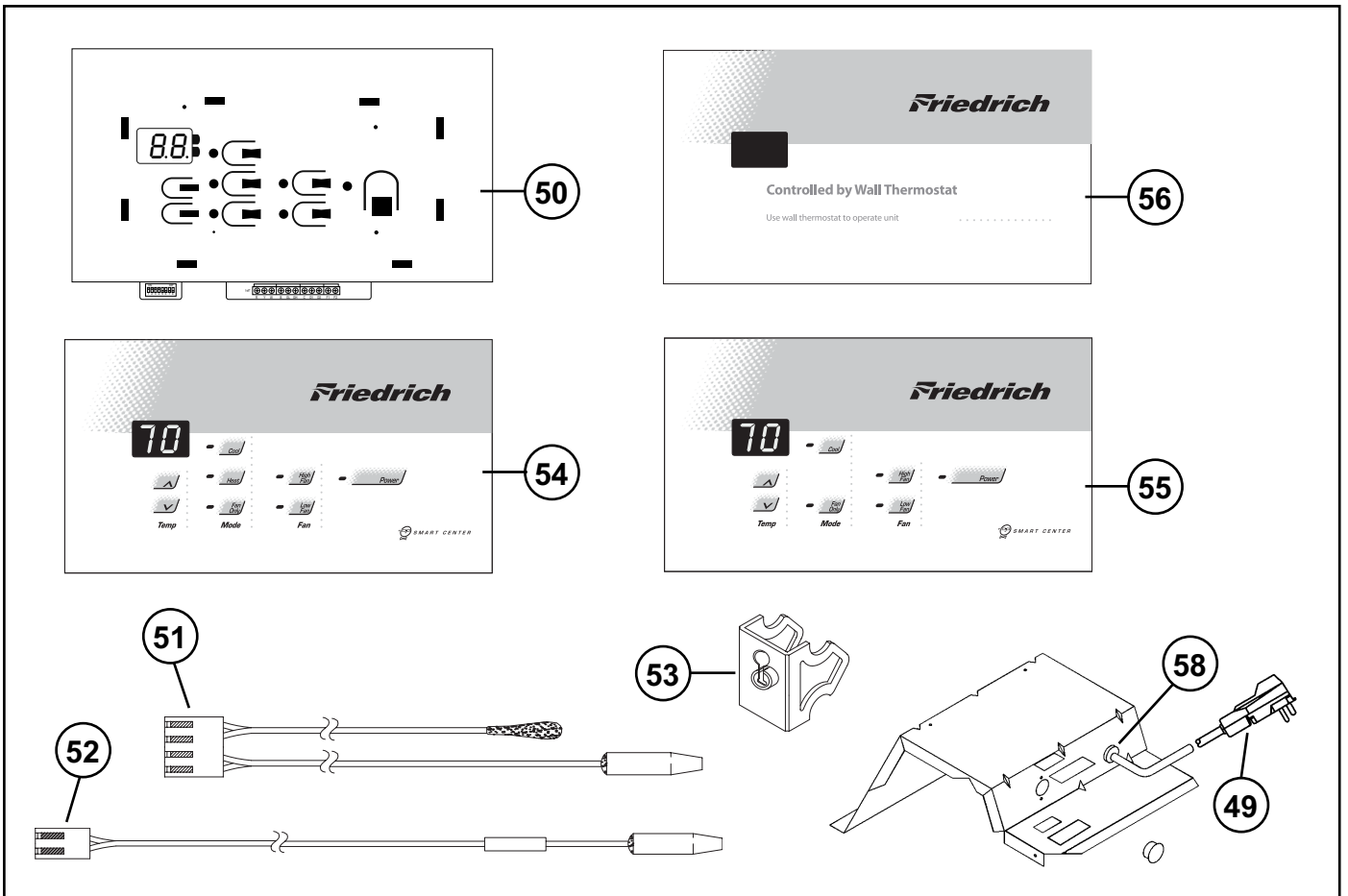

REF.	PART NO.	DESCRIPTION	07	09	12	15	NOTES
49	60500190	LCDI, 15A (2.5kW @ 230 Volt)	1	1	1	1	
49	60500191	LCDI, 20A (3.4kW @ 230 Volt)	1	1	1	1	
49	60500192	LCDI, 30A (5.0kW @ 230 Volt)	1	1	1	1	
58	20061450	Strain Relief 15/20A	1	1	1	1	
58	20086915	Strain Relief 30A	1	1	1	1	
50	25070050	Electronic Control Kit	1	1	1	1	See Note*
51	61921152	Dual Thermistor	1	1	1	1	
52	61921153	Single Thermistor	1	1	1	1	Heat Pump
53	25067900	Thermistor Holder	2	2	2	2	
54	25070102	Heat Cool Escutcheon	1	1	1	1	
55	25070103	Cool Only Escutcheon	1	1	1	1	
56	25070104	Remote Thermostat Escutcheon	1	1	1	1	
N/S	61080541	Capacitor, 20/5 @ 370 (230 Volt)	1	-	-	-	
N/S	61080573	Capacitor, 15/5 @ 440 (265 Volt)	1	-	-	-	
N/S	61080539	Capacitor, 25/5 @ 370 (230 Volt)	-	1	-	-	
N/S	61080571	Capacitor, 20/5 @ 440 (265 Volt)	-	1	-	-	
N/S	61080565	Capacitor, 30/5 @ 370 (230 Volt)	-	-	1	-	
N/S	61080571	Capacitor, 20/5 @ 440 (265 Volt)	-	-	1	-	
N/S	61080565	Capacitor, 30/5 @ 370 (230 Volt)	-	-	-	1	
N/S	61080571	Capacitor, 20/5 @ 440 (265 Volt)	-	-	-	1	

\*Note: **Electronic Control Kit includes:** Electronic Control Board, Dual Thermister, Single Thermister, Thermister Holder (2), Escutcheons (Heat/Cool, Cool Only, Remote Thermostat) and Installation Instructions

# FRONT COVER

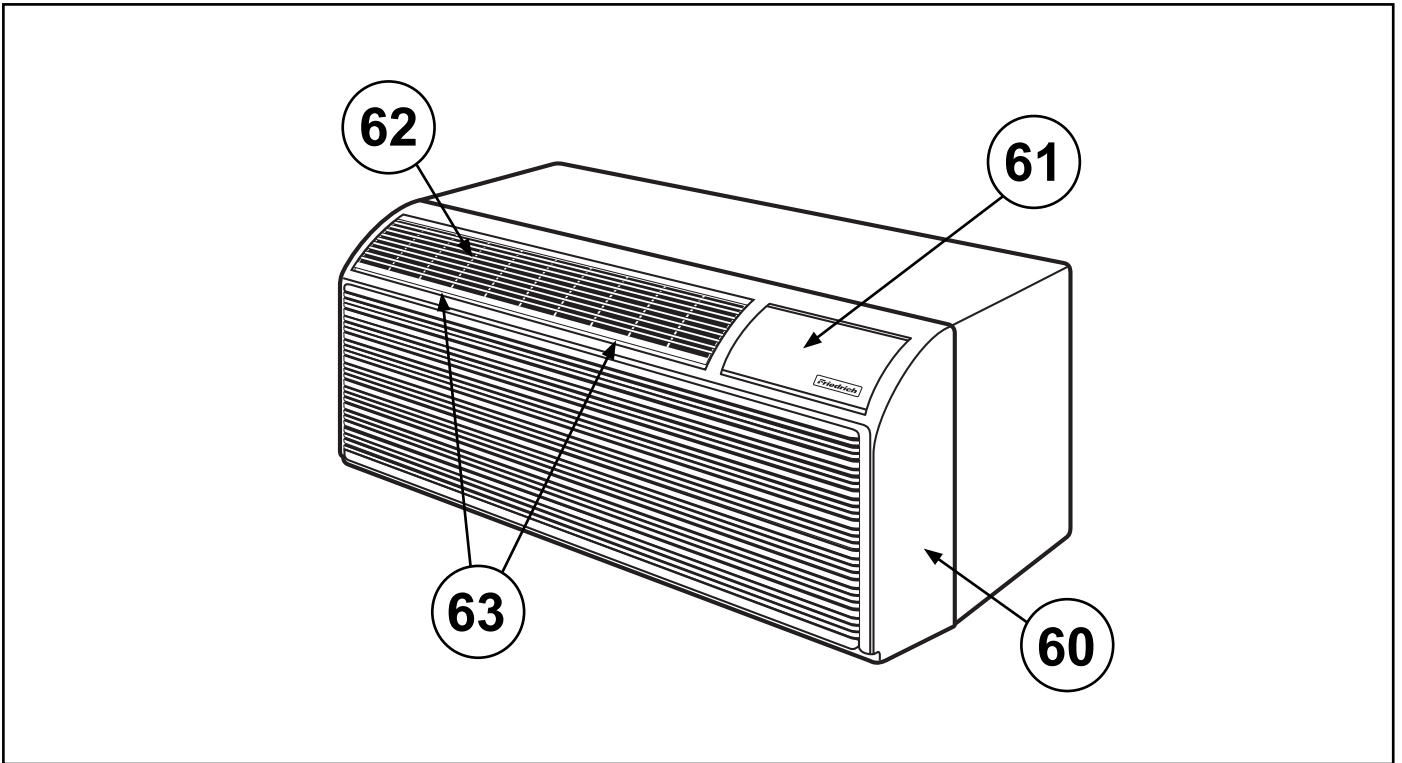

REF.	PART NO.	DESCRIPTION	07	09	12	15	NOTES
60	25037904	Front Cover Complete (Includes Door and Filters)	1	1	1	1	
61	25031903	Control Door	1	1	1	1	
62	25025903	Grille, Discharge	1	1	1	1	
63	25037804	Filter	2	2	2	2	
N/S	25060600	Thumb Screw	2	2	2	2	
N/S	25060500	Speed Nut (U-Type)	2	2	2	2	



**Use Factory Certified Parts.**

***Friedrich***

**FRIEDRICH AIR CONDITIONING CO.**

Post Office Box 1540 · San Antonio, Texas 78295-1540

4200 N. Pan Am Expressway · San Antonio, Texas 78218-5212

(210) 357-4400 · FAX (210) 357-4480

[www.friedrich.com](http://www.friedrich.com)

Printed in the U.S.A.

PTACPRTS PD B-A (1-05)