

This Owner's Manual is provided and hosted by [Appliance Factory Parts](#).

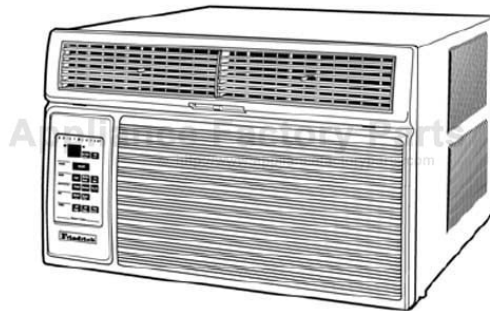

FRIEDRICH XQ06J10-A Owner's Manual

[Shop genuine replacement parts for FRIEDRICH
XQ06J10-A](#)



[Find Your FRIEDRICH Air Conditioner Parts - Select From 1575 Models](#)

----- Manual continues below -----

2002 Room Air Conditioning Parts Manual



Friedrich[®]

TABLE OF CONTENTS

	PAGE
PORTABLE "Q" SERIES UNITS	3-15
SMALL CHASSIS "S" SERIES UNITS (115 & 230 VOLT)	16-25
MEDIUM CHASSIS "M" SERIES UNITS (115 & 230 VOLT)	26-31
LARGE CHASSIS "L" SERIES UNITS	32-37
WALL MASTER "WM" SERIES UNITS (115 & 230 VOLT)	38-43

**"Q" Series
Portable Chassis
Room Air Conditioner Section**

"Q" SERIES CABINET PARTS (KQ, SQ, YQ)

NOTE: Items 51, 56 and 57 are not included with the "YQ" unit.



"Q" SERIES CHASSIS PARTS (ZQ05A10A & ZQ07A10A)

**NOTE: Box A for ZQ05A10A
& ZQ07A10A**

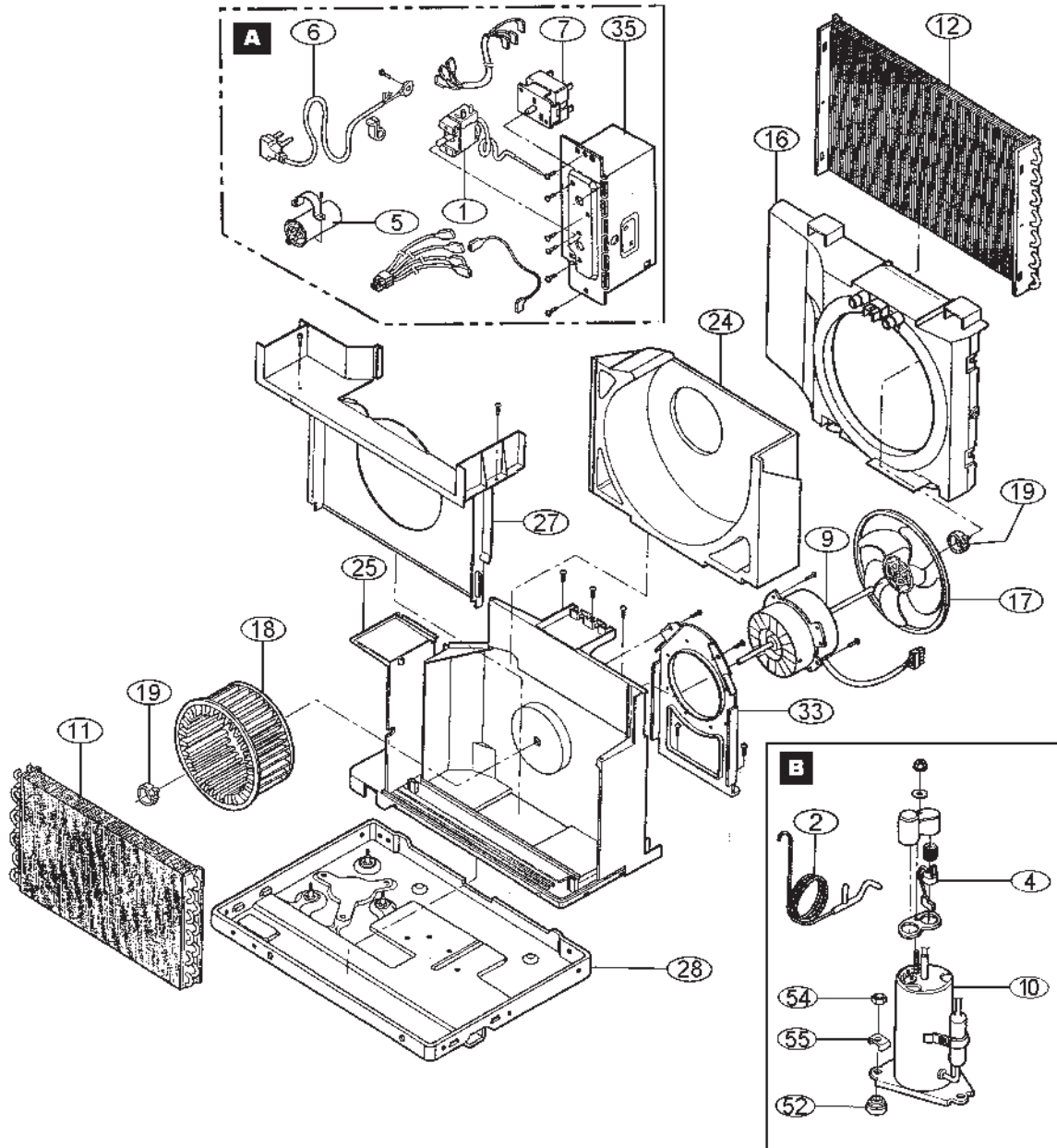

"Q" SERIES CHASSIS PARTS (ZQ05A10A & ZQ07A10A)

**NOTE: Box A for ZQ05A10A
& ZQ07A10A**



**"Q" SERIES CHASSIS PARTS
(ZQ08A10B & ZQ10A10A)**

**NOTE: Box C is for ZQ08A10B
AND ZQ10A10A**



**NOTE: Box B is for all
ZQ Models**

**"Q" SERIES CABINET PARTS
(ZQ05A10A & ZQ07A10A)**

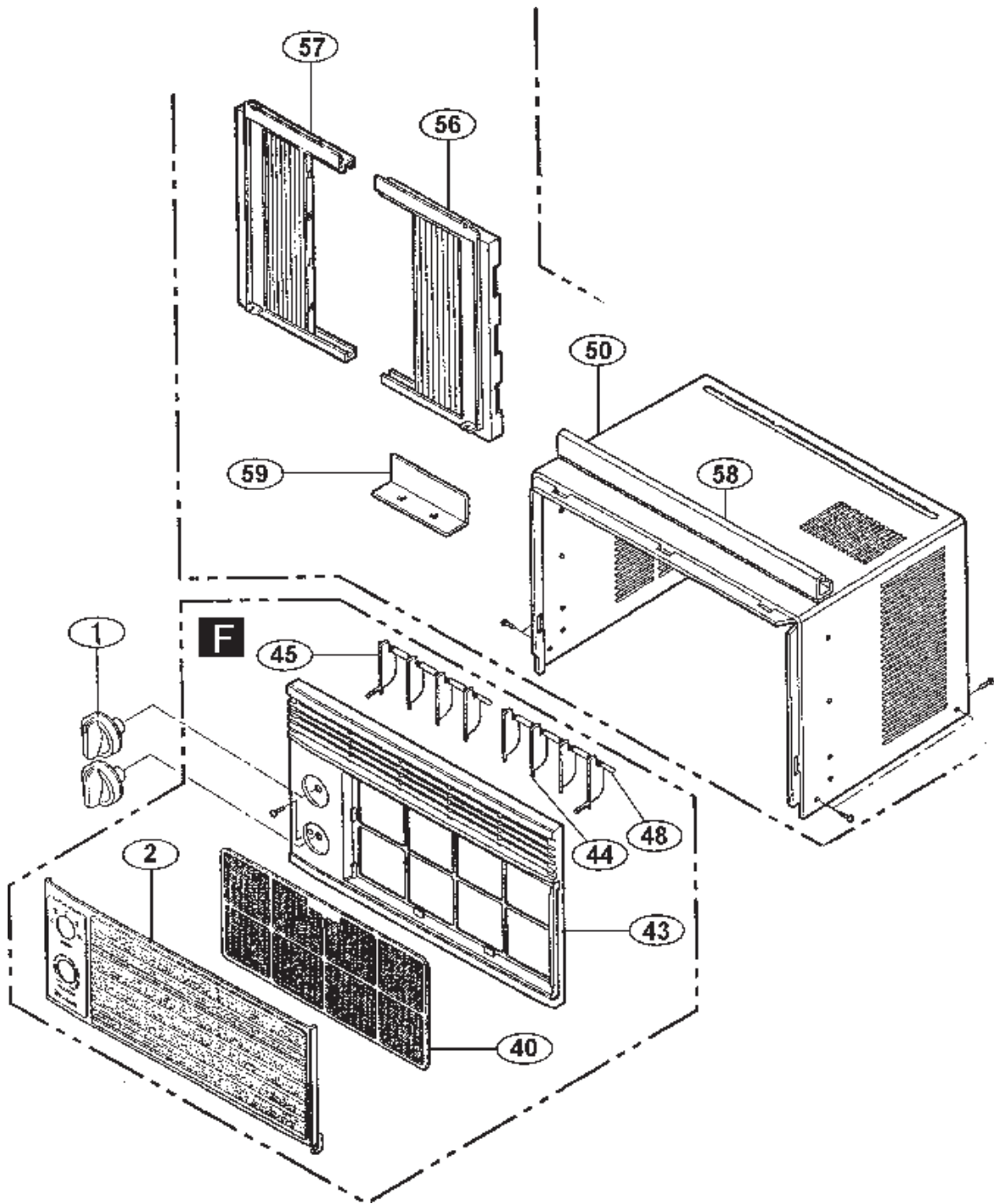

**"Q" SERIES CABINET PARTS
(ZQ08A10B & ZQ10A10A)**



"S" Series
115V / 230 V
Small Chassis
Room Air Conditioner Section

SMALL CHASSIS "S" SERIES CHASSIS PARTS (EK, ES, KS, RS, SS & YS)



SMALL CHASSIS "S" SERIES CHASSIS PARTS (EK, ES, KS, RS, SS & YS)



SMALL CHASSIS "S" SERIES PARTS LIST

REF	DESCRIPTION	PART NO#	KS 115					RS 115			SS 115					YS 115		CODE	
			KS10E10-A	KS12E10-A	KS10J10-B	KS12J10A-A	KS12J10B-A	RS12J10A-B	RS10J10B	RS10J10C	SS08J10R-A	SS09J10B-A	SS09J10C-A	SS10J10AR-A	SS10J10R-A	SS12J10AR-A	SS12J10AR-B		YS09J10A-A
1	THERMOSTAT	61822500	1	1	1	1	1	1	1	1								120	
1	THERMOSTAT	61822400															1	1	122
*	THERMOSTAT, DEFROST	61350313															1	1	122
2	ELECTRONIC CTRL.	61921103									1	1	1	1	1	1			331
*	REMOTE CONTROL	61826602									1	1	1	1	1	1			350
3	RESISTOR BLOCK	61808000			1	1	1	1		1							1	1	200
*	OVERLOAD	60364598			1														190
*	OVERLOAD	61764519	1	1	1				1	1						1			190
*	OVERLOAD	61764504				1	1	1							1				190
*	OVERLOAD	60364594											1	1			1	1	190
*	OVERLOAD	61764536											1						190
*	OVERLOAD	61764507									1								190
*	OVERLOAD	61764510										1							190
4	CAPACITOR	61080538											1	1			1	1	150
4	CAPACITOR	61080554	1							1			1						150
4	CAPACITOR	61080569		1												1			150
4	CAPACITOR	61080535			1	1	1	1	1	1		1	1			1			150
6	SUPPLY CORD	60500054	1		1				1	1	1	1	1	1	1	1	1	1	220
6	SUPPLY CORD	60500053		1		1	1												220
6	SWITCH	60607203	1	1	1	1	1												130
6	SWITCH	60607205						1	1	1									130
6	SWITCH	60607204															1	1	130
7	SWITCH (YES - NO)	61806102	1	1	1	1	1	1	1	1							1	1	132
8	FAN MOTOR	61871431	1		1														110
8	FAN MOTOR	61871428							1	1	1	1	1		1				110
8	FAN MOTOR	61871430												1	1				110
8	FAN MOTOR	61871436		1		1											1	1	110
8	FAN MOTOR	61071480			1	1													110
8	FAN MOTOR	61071493					1												110
8	FAN MOTOR	61071476											1						110
8	FAN MOTOR	61071479						1								1			110
*	SOLENOID COIL	25063500															1	1	240

* PARTS NOT SHOWN

SMALL CHASSIS "S" SERIES PARTS LIST

REF	DESCRIPTION	PART NO#	KS 115					RS 115			SS 115					YS 115		CODE	
			KS10E10-A	KS12E10-A	KS10J10-B	KS12J10A-A	KS12J10B-A	RS12J10A-B	RS10J10B	RS10J10C	SS08J10R-A	SS09J10B-A	SS09J10C-A	SS10J10AR-A	SS10J10R-A	SS12J10AR-A	SS12J10AR-B		YS09J10A-A
9	COMPRESSOR	61716640																	600
9	COMPRESSOR	61562838				1													600
9	COMPRESSOR	61562832								1									600
9	COMPRESSOR	61562833									1								600
9	COMPRESSOR	61716622	1		1														600
9	COMPRESSOR	61716640		1															600
9	COMPRESSOR	61562608										1							600
9	COMPRESSOR	61716641							1										600
9	COMPRESSOR	61562838					1	1							1				600
9	COMPRESSOR	61562802										1							600
9	COMPRESSOR	61562832									1								600
9	COMPRESSOR	61562833										1							600
9	COMPRESSOR	61562802											1						600
9	COMPRESSOR	61562807												1			1	1	600
10	EVAPORATOR COIL	61850101			1	1				1		1							400
10	EVAPORATOR COIL	61850100	1	1		1	1	1	1	1	1	1	1	1	1	1	1	1	400
11	CONDENSER COIL	61850303			1							1		1					410
11	CONDENSER COIL	61850217		1	1	1	1									1			410
11	CONDENSER COIL	61850302	1					1	1	1		1			1	1	1	1	410
11	CONDENSER COIL	61850300										1	1						410
*	DRIER, LIQUID	60308101	1	1	1	1	1	1		1	1	1	1	1		1	1	1	480
*	DRIER, SUCTION	61828200	1	1	1	1	1	1		1	1	1	1	1		1	1	1	480
*	CHECK VALVE/CAP ASSY	61865300															1	1	510
*	CHECK VALVE	61824400															1	1	510
*	REVERSING VALVE	25018200															1	1	500
*	CAPILLARY TUBE (HTG)	03760513															1	1	471
*	CAPILLARY TUBE (CLG)	03760554															1		471
*	CAPILLARY TUBE	03760556																1	471
*	CAPILLARY TUBE	03760511							1										471
*	CAPILLARY TUBE	03760520	1		1	1	1	1		1					1				471
*	CAPILLARY TUBE	03760473		1									1	1		1			471
*	CAPILLARY TUBE	01389903										1							471
*	CAPILLARY TUBE	01390212			1						1								471
*	CAPILLARY TUBE	03760548								1									471

* PARTS NOT SHOWN

SMALL CHASSIS "S" SERIES PARTS LIST

REF	DESCRIPTION	PART NO#	KS					RS			SS						YS		CODE
			KS10E10-A	KS12E10-A	KS10J10-B	KS12J10A-A	KS12J10B-A	RS12J10A-1	RS10J10-B	RS10J10C	SS08J10R-A	SS09J10B-A	SS09J10C-A	SS10J10AR-A	SS10J10R-A	SS12J10AR-A	SS12J10AR-B	YS09J10A-A	
12	SHROUD, CONDENSER	61803600	1	1	1	1	1	1	1	1	1	1	1	1	1	1	1	1	720
*	SHROUD, SML W/SUMP LOOP	61803601	1	1	1	1		1	1	1	1	1	1	1	1	1	1	1	720
13	FAN BLADE, CONDENSER	60542003	1	1	1	1	1	1	1	1	1	1	1	1	1	1	1	1	710
14	BLOWER WHEEL, EVAPORATOR	60610603		1	1			1				1	1	1				700	
14	BLOWER WHEEL, EVAPORATOR	60610604	1							1								700	
14	BLOWER WHEEL, EVAPORATOR	60610601				1	1											700	
14	BLOWER WHEEL, EVAPORATOR	60610607						1					1	1				700	
15	BRACE, COND. SHROUD	61802600	3	3	3	3	3	3	3	3	3	3	3	3	3	3	3	722	
16	SCROLL	61814900	1	1	1	1	1	1			1	1	1	1	1	1	1	743	
16	SCROLL	61814902						1	1	1					1			743	
17	BLOWER FRONT	61817300	1	1	1	1	1	1	1	1	1	1	1	1	1	1	1	742	
*	INSULATION, INNER WALL	61816900	1	1	3	3	1	1	1	1	1	1	1	1	1	3	1	781	
18	INNER WALL	61907300	1	1	1	1	1	1	1	1	1	1	1	1	1	1	1	777	
19	COVER, TOP	61906700	1	1	1	1	1	1	1	1	1	1	1	1	1	1	1	746	
20	INSULATION, TOP COVER	61816701	1	1	1	1	1	1	1	1	1	1	1	1	1	1	1	781	
21	DECK	61817100	1	1	1	1	1	1	1	1	1	1	1	1	1	1	1	745	
22	AIR FOIL	61820200	1	1	1	1	1	1	1	1	1	1	1	1	1	1	1	744	
23	MOUNT, FAN MOTOR	61802500	1	1	1	1	1	1	1	1	1	1	1	1	1	1	1	900	
24	SHIELD, BOTTOM	61812900															1	999	
25	BRACKET, HEATER MT.	61818900																999	
26	SHIELD, SIDE	61821800															1	999	
27	BASE PAN	61803409				1	1	1			1	1	1		1	1		730	
27	BASE PAN	61803411	1	1	1				1	1			1	1				730	
27	BASE PAN	61809001															1	730	
*	DRAIN PAN	61803800	1	1	1	1	1	1	1	1	1	1	1	1	1	1	1	840	
*	BELLOWS, DRAIN VALVE	60179900															1	801	
*	GRILLE, REAR	61818800	1	1	1	1	1	1	1	1	1	1	1	1	1	1	1	771	
28	DOOR, SLIDE ASSLY.	61821500	1	1	1	1	1	1	1	1	1	1	1	1	1	1	1	810	
*	CONNECTOR, SLIDE DOOR	61814800	1	1	1	1	1	1	1	1	1	1	1	1	1	1	1	811	
29	PANEL, CTRL. MT.	61807200	1	1	1	1	1	1	1	1							1	999	
29	PANEL, CTRL. MT.	61807201									1	1	1	1	1	1		999	
30	BRACKET, CAP. MT	61820400	1	1	1	1	1	1			1	1	1	1	1	1	1	999	
*	PANEL, L/S	61937200	1	1	1	1		1	1	1	1	1	1	1	1	1	1	999	
*	PANEL, LIS	61907000			1	1	1	1			1	1	1	1	1	1		999	
31	PARTITION, CTRL. BOX	61802800	1	1	1	1	1	1	1	1	1	1	1	1	1	1	1	999	
32	DECORATIVE PANEL	61822603						1	1	1								999	
*	BUSHING, SUPPLY CORD	60071312	1	1	1	1	1	1	1	1	1	1	1	1	1	1	1	999	
32	DECORATIVE PANEL	61822600	1	1	1	1	1	1										999	
33	KNOBS, CTRL.	61493905	2	2	2	2	2	2	2	2							2	761	
*	HOLDER, THERMISTER	61925001									1	1	1	1	1	1		764	
*	HOLDER, AIR FILTER	61823000	2	2	2	2	2	2	2	2	2	2	2	2	2	2	2	756	
*	FILTER, AIR	60865808	1	1	1	1	1	1	1	1	1	1	1	1	1	1	1	754	
*	CLAMP, SUPPLY CORD	91500301	1	1	1	1	1	1	1	1	1	1	1	1	1	1	1	999	
*	BRACKET, RESISTO BLOCK	61820600	1	1	1	1	1	1	1	1							1	999	
34	GROMMET, SUCTION LINE	61807602	1	1	1	1	1	1	1	1	1	1	1	1	1	1	1	999	
34	GROMMET, COMPRESSOR	61028900	3	3	3	3	3	3	3	3	3	3	3	3	3	3	3	790	
35	SCREW, COMPRESSOR MT.	91400400	3	3	3	3	3	3	3	3	3	3	3	3	3	3	3	999	
*	COUNTER WEIGHT	61715800	2	2	2	2	2	2	2	2	2	2	2	2	2	2	2	999	
36	PLENUM ASSLY.	61810200	1	1	1	1	1	1	1	1	1	1	1	1	1	1	1	753	

* PARTS NOT SHOWN

SMALL CHASSIS "S" SERIES PARTS LIST

REF	DESCRIPTION	PART NO#	KS					RS			SS						YS		CODE			
			KS10E10-A	KS12E10-A	KS10J10-B	KS12J10A-A	KS12J10B-A	RS12J10A-1	RS10J10-B	RS10J10C	SS08J10R-A	SS09J10B-A	SS09J10C-A	SS10J10AR-A	SS10J10R-A	SS12J10AR-A	SS12J10AR-B	YS09J10A-A		YS09J10B-A		
*	LEVER, FRESH & EXHAUST	61809200	1	1	1	1	1	1	1	1	1	1	1	1	1	1	1	1	1	1	999	
*	KNOB, FRESH & EXHAUST	61809300	1	1	1	1	1	1	1	1	1	1	1	1	1	1	1	1	1	1	764	
37	INTAKE GRILLE	61808900	1	1	1	1	1	1	1	1	1	1	1	1	1	1	1	1	1	1	772	
*	LATCH, INTAKE GRILLE	61819900	2	2	2	2	2	2	2	2	2	2	2	2	2	2	2	2	2	2	999	
38	OUTER SHELL ASSLY	61803205	1	1	1	1	1	1	1	1	1	1	1	1	1	1	1	1	1	1	770	
39	SILL PLATE	61808403	1	1	1	1	1	1	1	1	1	1	1	1	1	1	1	1	1	1	999	
*	CHASSIS GUIDE, SHELL	61819601	2	2	2	2	2	2	2	2	2	2	2	2	2	2	2	2	2	2	999	
*	FRIEDRICH SCRIPT	60169105			1	1	1	1	1	1	1	1	1	1	1	1	1	1	1	1	999	
*	PUSHNUTS, SCRIPT	91002900	2	2	2	2	2	2	2	2	2	2	2	2	2	2	2	2	2	2	999	
*	ACCESSORY PKGE.	61105004			1	1	1	1	1	1	1	1	1	1	1	1	1	1	1	1	999	
40	WINGBOARD	60294408	1	1	1	1	1	1	1	1	1	1	1	1	1	1	1	1	1	1	999	
41	BRACKET, SUPPORT	61109503	2	2	2	2	2	2	2	2	2	2	2	2	2	2	2	2	2	2	999	
42	ANGLE, WINGBOARD	61819801	2	2	2	2	2	2	2	2	2	2	2	2	2	2	2	2	2	2	999	
43	ANGLE, TOP	61819701	1	1	1	1	1	1	1	1	1	1	1	1	1	1	1	1	1	1	999	
44	GASKET, VINYL	60610303	1	1	1	1	1	1	1	1	1	1	1	1	1	1	1	1	1	1	999	
*	HARDWARE BAG(SCREWS)	60846017																		1	1	999
*	HARDWARE BAG(SCREWS)	60846016	1	1	1	1	1	1	1	1	1	1	1	1	1	1	1	1	1	1	999	
45	GASKET, CHASSIS	61717301	1	1	1	1	1	1	1	1	1	1	1	1	1	1	1	1	1	1	999	
45	GASKET, WINDOW	60073300			1	1	1	1	1	1	1	1	1	1	1	1	1	1	1	1	999	
*	CARTON, SHIPPING	61839800										1	1	1	1	1	1	1	1	1	999	
*	PAD, SHIPPING	61839500	1	1	1	1	1	1	1	1	1	1	1	1	1	1	1	1	1	1	999	
*	PAD, FRONT SUPPORT	61839700	1	1	1	1	1	1	1	1	1	1	1	1	1	1	1	1	1	1	999	
*	PAD, SHIPPING TOP	61839600	1	1	1	1	1	1	1	1	1	1	1	1	1	1	1	1	1	1	999	
*	CARTON, SHIPPING	61839801	1	1	1	1	1	1	1	1	1	1	1	1	1	1	1	1	1	1	999	
OPTIONAL ACCESSORIES																						
*	ACCESSORY PACKAGE	WIKS																		1	1	
*	DRAIN KIT, DC-2	01900235	1	1	1	1	1	1	1			1	1		1	1		1	1	1		
*	START KIT, CAP.RELAY	61008903	1	1	1	1	1	1	1			1	1		1	1		1	1	1		
*	REMOTE CONTROLLER	61826602										1								1		
*	INSTALLATION BOOK	92003601			1	1	1	1	1			1	1		1	1				1	1	
*	INSTALLATION BOOK	92003602																	1			
*	OPERATION BOOK	92000304																		1	1	
*	OPERATION BOOK	92000505			1	1	1	1	1													
*	OPERATION BOOK	92006102							1													
*	OPERATION BOOK	92009002										1	1		1	1		1				
*	QUICK REF. CARD	92004401										1	1		1	1		1				
*	PARTS MANUAL	92013200			1	1	1	1	1			1	1		1	1		1	1	1		
*	SERVICE MANUAL	92013100			1	1	1	1	1			1	1		1	1		1	1	1		

* PARTS NOT SHOWN

SMALL CHASSIS "S" SERIES PARTS LIST

REF	DESCRIPTION	PART NO#	EK 230	ES 230	KS 230	RS 230	SS 230	YS 230	CODE	
	ELECTRICAL PARTS		EK12J33B-A	ES12J33-A	ES16J33A-A	KS12J30B-A	RS16J30A-A	SS12J30B-A	SS16J30A-A	YS12J33-A
1	THERMOSTAT	61822400	1	1	1				1	120
1	THERMOSTAT	61822500				1	1			120
*	THERMOSTAT, DEFROST	61350313							1	122
2	ELECTRONIC CTR.	61921104					1	1		331
3	RESISTOR	61808001	1	1	1	1	1		1	200
*	OVERLOAD	60364596					1			190
*	OVERLOAD	61764521	1	1		1	1		1	190
*	OVERLOAD	61764532			1	1		1		190
*	OVERLOAD	60364597								190
4	CAPACITOR	61080536	1			1		1		150
4	CAPACITOR	61080537		1	1		1		1	150
5	SUPPLY CORD	60500049	1	1	1					220
5	SUPPLY CORD	60500051				1	1	1	1	220
6	SWITCH	60607204	1	1	1					130
6	SWITCH	60607203				1				130
6	SWITCH	60607205					1			130
7	SWITCH (YES - NO)	61806102	1	1	1	1	1			132
8	FAN MOTOR	61871429					1		1	110
8	FAN MOTOR	61871437	1	1		1				110
8	FAN MOTOR	61871438			1					110
8	FAN MOTOR	61871429					1		1	110
8	FAN MOTOR	61871441						1		110
*	SOLENOID	25063600								240
8A	HEATER	61878600	1	1	1					210
*	FUSE LINK	61596301	1	1	1					192
*	LIMITER, HEATER	61827900	1	1	1					193
REFRIGERATION SYSTEM PARTS										
9	COMPRESSOR	61562804						1		600
9	COMPRESSOR	61716631			1		1		1	600
9	COMPRESSOR	61716628	1			1				600
9	COMPRESSOR	61716609		1						600
9	COMPRESSOR	61562828			1		1		1	600
9	COMPRESSOR	61562805								600
10	EVAPORATOR COIL	61850005			1		1		1	400
10	EVAPORATOR COIL	61850100		1						400
10	EVAPORATOR COIL	61850101	1			1		1		400
11	CONDENSER COIL	61850217	1			1				410
11	CONDENSER COIL	61850302		1	1		1	1		410
11	CONDENSER COIL	61850306								410
*	DRIER, LIQUID	60308101	1	1	1	1	1	1	1	480
*	DRIER, SUCTION	61828200	1	1	1	1	1	1	1	480
*	CHECK VALVE	61824400								510
*	REVERSING VALVE	25018300								500
*	CAPILLARY TUBE (HTG)	03760513								471
*	CAPILLARY TUBE (CLG)	03760545								471
*	CAPILLARY TUBE	01390212				1				471
*	CAPILLARY TUBE	03760511								471
*	CAPILLARY TUBE	01390000						1		471
*	CAPILLARY TUBE	01390005					1		1	471
*	CAPILLARY TUBE	03760520	1	1	1	1				471

* PARTS NOT SHOWN

SMALL CHASSIS "S" SERIES PARTS LIST

REF	DESCRIPTION	PART NO#	EK 230	ES 230	KS 230	RS 230	SS 230	YS 230	CODE		
	CHASSIS PARTS		EK12J33B-A	ES12J33-A	ES16J33A-A	KS12J30B-A	RS16J30A-A	SS12J30B-A	SS16J30A-A	YS12J33-A	
12	SHROUD, CONDENSER	61803600	1	1	1	1	1	1	1	1	720
13	FAN BLADE	60542003	1	1	1	1	1	1	1	1	710
14	BLOWER WHEEL	60610601			1		1		1		700
14	BLOWER WHEEL	60610603	1	1		1		1		1	700
15	BRACE, COND. SHROUD	61802600	3	3	3	3	3	3	3	3	722
16	SCROLL	61814900	1	1	1	1	1	1	1	1	743
17	BLOWER FRONT	61817300	1	1	1	1	1	1	1	1	742
*	INSULATION, INNER WALL	61816900	1	1	1	1	1	1	1	1	781
18	INNER WALL	61907300	1	1	1	1	1	1	1	1	777
19	COVER, TOP	61906700	1	1	1	1	1	1	1	1	746
20	INSULATION, TOP COVER	61816701	1	1	1	1	1	1	1	1	781
21	DECK	61817100	1	1	1	1	1	1	1	1	745
22	AIR FOIL	61820200	1	1	1					1	744
22	AIR FOIL	61820202	1	1	1	1	1	1	1		744
23	MOUNT, FAN MOTOR	61802500	1	1	1	1	1	1	1	1	900
24	SHIELD, BOTTOM	61812900		1	1	1	1	1	1	1	999
24	SHIELD, BOTTOM	61812902	1								999
25	BRACKET, HEATER MT.	61818900	1	1	1					1	999
26	SHIELD, SIDE	61821800	1	1	1	1	1	1	1	1	999
27	BASE PAN	61809005	1	1	1						730
27	BASE PAN	61803411				1	1	1	1		730
27	BASE PAN	61809001								1	730
*	DRAIN PAN	61803800	1	1	1	1	1	1	1	1	840
*	BELLOWS, DRAIN VALVE	60179900	1	1	1					1	801
*	GRILLE, REAR	61818800	1	1	1	1	1	1	1	1	771
28	DOOR, SLIDE ASSLY.	61821500	1	1	1	1	1	1	1	1	810
*	CONNECTOR, SLIDE DOOR	61814800	1	1	1	1	1	1	1	1	811
29	PANEL, CTRL. MT.	61807201							1		999
29	PANEL, CTRL. MT.	61807200	1	1	1	1	1			1	999
30	BRACKET, CAP. MT	61820400	1	1	1	1	1	1	1	1	999
*	PANEL, LIS	61937200	1	1	1	1	1	1	1	1	999
31	PARTITION, CTRL. BOX	61802800				1	1	1	1		999
31	PARTITION, CTRL. BOX	61802801	1	1	1					1	999
*	BUSHING, SUPPLY CORD	60071311	1	1	1					1	999
*	BUSHING, SUPPLY CORD	60071312	1	1	1	1	1	1	1	1	999
32	DECORATIVE PANEL	61823300	1	1	1	1	1	1	1	1	999
32	DECORATIVE PANEL	61822600	1	1	1	1				1	999
33	KNOBS, CTRL.	61493905	2	2	2	2	2			2	761
29	PANEL, CONTROL SML	61807200								1	999
29	PANEL, CONTROL	61807201						1	1		999
*	HOLDER, THERMISTER	61925001						1	1		764
*	HOLDER, AIR FILTER	61823000	2	2	2	2	2	2	2	2	756
*	FILTER, AIR	60865808	1	1	1	1	1	1	1	1	754
*	CLAMP, SUPPLY CORD	91500301	1	1	1	1	1	1	1	1	999
*	BRACKET, RESISTO BLOCK	61820600	1	1	1	1	1	1	1	1	999
*	GROMMET, SUCTION LINE	61807602	1	1	1	1	1	1	1	1	999
34	GROMMET, COMPRESSOR	61028900	3	3	3	3	3	3	3	3	790
35	SCREW, COMPRESSOR MT.	91400400	3	3	3	3	3	3	3	3	999
*	COUNTER WEIGHT	61715800	2	2	2	2	2	2	2	2	999
36	PLENUM ASSLY.	61810200	1	1	1	1	1	1	1	1	753
*	KNOB, FRESH AIR & EXHAUST	61809300	1	1	1	1	1	1	1	1	761

* PARTS NOT SHOWN

SMALL CHASSIS "S" SERIES PARTS LIST

REF	DESCRIPTION	PART NO#	EK 230	ES 230		KS 230	RS 230	SS 230		YS 230	CODE
			EK12J33B-A	ES12J33-A	ES16J33A-A	KS12J30B-A	RS16J30A-A	SS12J30B-A	SS16J30A-A	YS12J33-A	
	ELECTRICAL PARTS										
37	INTAKE GRILLE	61808900	1	1	1	1	1	1	1	1	772
*	LATCH, INTAKE GRILLE	61819900	2	2	2	2	2	2	2	2	999
38	OUTER SHELL ASSLY	61803205	1	1	1	1	1	1	1	1	999
39	SILL PLATE	61808403	1	1	1	1	1	1	1	1	999
*	CHASSIS GUIDE, SHELL	61819601	2	2	2	2	2	2	2	2	999
*	FRIEDRICH SCRIPT	60169105	1	1	1	1	1	1	1	1	999
*	PUSHNUTS, SCRIPT	91002900	2	2	2	2	2	2	2	2	999
*	ACCESSORY PKGE.	61105004	1	1	1	1	1	1	1	1	999
40	WINGBOARD	60294408	1	1	1	1	1	1	1		999
41	BRACKET, SUPPORT	61109503				2	2	2	2		999
42	ANGLE, WINGBOARD	61819801				2	2	2	2		999
43	ANGLE, TOP	61819701				1	1	1	1		999
44	GASKET, VINYL	60610303	1	1	1	1	1	1	1	1	999
*	HARDWARE BAG(SCREWS)	60846017	1	1	1					1	999
*	HARDWARE BAG(SCREWS)	60846016				1	1	1	1		999
45	GASKET, CHASSIS	61717301	1	1	1	1	1	1	1	1	999
45	GASKET, WINDOW	60073300	1	1	1	1	1	1	1		999
*	PAD, SHIPPING TOP	61839600	1	1	1	1	1	1	1	1	999
*	PAD, SHIPPING	61839500	1	1	1	1	1	1	1		999
*	PAD, FRONT SUPPORT	61839700	1	1	1	1	1	1	1	1	999
*	CARTON, SHIPPING	61839800						1	1		999
*	CARTON, SHIPPING	61839801	1	1	1	1	1			1	999
OPTIONAL ACCESSORIES											
*	DRAIN KIT, DC-2	01900235	1	1	1	1	1	1	1	1	
*	START KIT, CAP.RELAY	61008903	1	1	1	1	1	1	1	1	
*	REMOTE CONTROLLER	61826602						1	1		
*	INSTALLATION BOOK	92003601	1	1	1	1	1	1	1	1	
*	OPERATION BOOK	92000304	1	1	1					1	
*	OPERATION BOOK	92000505				1					
*	OPERATION BOOK	92006102					1				
*	OPERATION BOOK	92000901						1	1		
*	QUICK REF. CARD	92004401						1	1		
*	PARTS MANUAL	92013200	1	1	1	1	1	1	1	1	
*	SERVICE MANUAL	92013100	1	1	1	1	1	1	1	1	

* PARTS NOT SHOWN

"M" Series
115 V / 230 V
Medium Chassis
Room Air Conditioner Section

Medium Chassis "M" SERIES CHASSIS PARTS (EK, EM, KM, RM, SM, & YM)



Medium Chassis "M" SERIES CABINET & MOUNTING PARTS (EK, EM, KM, RM, SM, YM)



MEDIUM CHASSIS "M" SERIES PARTS LIST

REF	DESCRIPTION	PART NO#	EK 230	EM 230	KM 115	KM 230	RM 115	RM 230	SM 115	SM 230	YM 230	CODE		
	ELECTRICAL PARTS		EK18J34B-A	EM19J34-B	KM14J10B-A	KM18J30B-A	KM21J30-A	RM14J10A-A	RM19J30-B	SM14J10R-A	SM19J30R-B	SM21J30B-A	YM18J34B-A	
1	THERMOSTAT	61822400	1	1									1	120
1	THERMOSTAT	61822500			1	1	1	1	1					120
*	THERMOSTAT, DEF.	61350313											1	122
2	ELECTRONIC BOARD	61921103							1					331
2	ELECTRONIC BOARD	61921104								1	1			331
*	REMOTE CONTROL	61826602							1	1				350
*	OVERLOAD	61764522			1			1	1					190
4	CAPACITOR	61080536		1		1					1		1	150
4	CAPACITOR	61080534					1					1		150
4	CAPACITOR	61080536	1			1								150
4	CAPACITOR	61080553						1						150
4	CAPACITOR	61080562			1			1		1				150
5	SUPPLY CORD	60500048	1	1									1	220
5	SUPPLY CORD	60500053			1			1		1				220
5	SUPPLY CORD	60500051				1			1		1			220
5	SUPPLY CORD	60500049					1					1		220
33	RESISTOR	61808001	1	1		1	1		1				1	200
33	RESISTOR	61808000			1			1						200
6	SWITCH	60607204	1	1									1	130
6	SWITCH	60607203			1	1	1							130
6	SWITCH	60607205						1	1					130
7	SWITCH (YES - NO)	61806102	1	1	1	1	1	1	1				1	132
8	FAN MOTOR	61871432						1	1	1		1		110
8	FAN MOTOR	61871442			1									110
8	FAN MOTOR	61871439	1	1		1	1							110
8	FAN MOTOR	61871432							1		1	1		110
*	SOLENOID COIL	25063600											1	240
8A	HEATER	61878601	1	1									1	210
REFRIGERATION SYSTEM PARTS														
9	COMPRESSOR	61716603		1					1		1		1	600
9	COMPRESSOR	61716617	1			1								600
9	COMPRESSOR	61716619			1			1		1				600
9	COMPRESSOR	61716607				1					1			600
9	COMPRESSOR	61716626						1						600
10	EVAPORATOR COIL	61850011	1			1								400
10	EVAPORATOR COIL	61850002		1	1		1	1	1	1	1			400
10	EVAPORATOR COIL	61850001											1	400
11	CONDENSER COIL	61850200	1	1	1	1	1	1	1	1	1			410
11	CONDENSER COIL	61850205											1	410
*	DRIER, LIQUID	60308101	1	1	1	1	1	1	1	1	1	1		480
*	DRIER, SUCTION	61828200	1	1	1	1	1	1	1	1	1	1	1	480
*	CHECK VALVE	61824400											1	510
*	REVERSING VALVE	25018700											1	500
*	CAPILLARY TUBE(HTG)	03760473											1	471
*	CAPILLARY TUBE(CLG)	03760555											1	471
*	CAPILLARY TUBE	01389975	1			1								471
*	CAPILLARY TUBE	03760479		3			3		3		3	3		471
*	CAPILLARY TUBE	03760500			1			1		1				471

* PARTS NOT SHOWN

MEDIUM CHASSIS "M" SERIES PARTS LIST

REF	DESCRIPTION	PART NO#	EK 230	EM 230	KM 115	KM 230	RM 115	RM 230	SM 115	SM 230	YM 230	CODE		
	CHASSIS PARTS		EK18J34B-A	EM19J34-B	KM14J10B-A	KM18J30B-A	KM21J30-A	RM14J10A-A	RM19J30-B	SM14J10R-A	SM19J30R-B	SM21J30B-A	YM18J34B-A	
12	SHROUD, CONDENSER	61804900	1	1	1	1	1	1	1	1	1	1	1	720
13	FAN BLADE, COND.	60542004	1	1	1	1	1	1	1	1	1	1	1	710
14	BLOWER WHEEL, EVAP.	60610601	1	1		1		1	1		1			700
14	BLOWER WHEEL, EVAP.	60610603			1			1		1				700
14	BLOWER WHEEL, EVAP.	60610605				1					1	1		700
15	BRACE, COND.SHROUD	61802600	3	3	3	3	3	3	3	3	3	3	3	722
16	SCROLL	61817500	1	1	1	1	1	1	1	1	1	1	1	743
17	BLOWER FRONT	61817400	1	1	1	1	1	1	1	1	1	1	1	742
*	INSULATION, LIS	61816800	1	1	1	1	1	1	1	1	1	1	1	781
20	INSULATION, TOP	61816701	1	1	1	1	1	1	1	1	1	1	1	781
	INSULATION, INNERWALL	61816901	1	1	1	1	1	1	1	1	1	1	1	781
18	INNER WALL	61907200	1	1	1	1	1	1	1	1	1	1	1	777
19	TOP COVER	61906700	1	1	1	1	1	1	1	1	1	1	1	746
21	DECK	61817100	1	1	1	1	1	1	1	1	1	1	1	745
22	AIR FOIL	61820200	1	1	1	1	1	1	1	1	1	1	1	744
24	SHIELD, BOTTOM	61812900	1											999
24	SHIELD, BOTTOM	61812901		1										999
26	SHIELD, SIDE	61821801	1	1									1	999
25	BRACKET, HTR	61818900	1	1									1	730
27	BASE PAN	61809005	1	1										730
27	BASE PAN	61803401			1	1	1	1	1	1	1	1		730
27	BASE PAN	61803411				1		1						730
27	BASE PAN	61809009											1	730
*	BELLOWS, DRAIN VALVE	60179900	1	1									1	801
*	DRAIN PAN, EVAP.	61803800	1	1	1	1	1	1	1	1	1	1	1	840
*	GRILLE, REAR	61818801	1	1	1	1	1	1	1	1	1	1	1	771
28	DOOR, SLIDE ASSY	61821500	1	1	1	1	1	1	1	1	1	1	1	810
*	CONNECTOR SLIDE ASSY	61814800	1	1	1	1	1	1	1	1	1	1	1	811
*	WIRE CLIP, SLIDE ASSY	60301800	1	1	1	1	1	1	1	1	1	1	1	999
29	PANEL, CTRL. MOUNT	61811000	1	1	1	1	1	1					1	999
29	PANEL, CTRL. MOUNT	61811001							1	1	1			999
*	PANEL, LIS MED	61937100	1		1	1	1	1	1	1	1			999
*	PANEL, LIS	61906900	1	1		1	1	1			1	1	1	999
31	PARTITION, CTRL. BOX	61804301	1	1									1	999
31	PARTITION, CTRL. BOX	61804300			1	1	1	1	1	1	1	1		999
30	BRACKET, CAP. MOUNT	61820400	1	1	1	1	1	1	1	1	1	1	1	999
*	STRAP, CAP.	61820700	1	1	1	1	1	1	1	1	1	1	1	999
32	DECORATIVE PANEL	61823300	1	1									1	999
32	DECORATIVE PANEL	61822600			1	1	1							999
32	DECORATIVE PANEL	61822603						1	1			1		999
33	KNOBS, CRTL.	61493905	2	2	2	2	2	2	2				2	761
*	BRACKET, RESISTOR BLK	61820600	1	1	1	1	1	1	1				1	999
*	BLOCK, RESISTOR	61808001	1	1	1	1	1	1					1	999
*	HOLDER, THERMISTOR	61925001								1	1	1		764
*	HOLDER, AIR FILTER	61823000	2	2	2	2	2	2	2	2	2	2	2	756
*	FILTER, AIR	60865809	1	1	1	1	1	1	1	1	1	1	1	754
*	CLAMP, SUPPLY CORD	91500302	1	1									1	999
*	CLAMP, SUPPLY CORD	91500301			1	1	1	1	1	1	1	1		999
34	GROMMET, COMP.	01150934				3						3		790
34	GROMMET, COMP.	61028900	3	3	3	3		3	3	3	3			790
35	SCREW, COMP.	91400400	3	3	3	3	3	3	3	3	3	3	3	999
*	COUNTER WEIGHT	61715800	1	1	1	1	2	1	2	1	1	2	1	999
*	GROMMET, SUCTION L.N.	61807600	1	1	1	1	1	1	1	1	1	1	1	999
23	MOUNT, FAN MOTOR	61804100	1	1	1	1	1	1	1	1	1	1	1	900

* PARTS NOT SHOWN

MEDIUM CHASSIS "M" SERIES PARTS LIST

REF	DESCRIPTION	PART NO#	EK 230	EM 230	KM 115	KM 230	RM 115	RM 230	SM 115	SM 230	YM 230	CODE		
	ELECTRICAL PARTS		EK18J34B-A	EM19J34-B	KM14J10B-A	KM18J30B-A	KM21J30-A	RM14J10A-A	RM19J30-B	SM14J10R-A	SM19J30R-B	SM21J30B-A	YM18J34B-A	
36	PLENIUM ASLY.	61810200	1	1	1	1	1	1	1	1	1	1	1	753
37	GRILLE, INTAKE	61811100	1	1	1	1	1	1	1	1	1	1	1	772
*	LATCH, GRILLE INTAKE	61819900	2	2	2	2	2	2	2	2	2	2	2	999
38	OUTER SHELL	61825701	1	1	1	1	1	1	1	1	1	1	1	770
39	SILL PLATE	61808403	1	1	1	1	1	1	1	1	1	1	1	999
*	CHASSIS GUIDE, SHELL	61819601	2	2	2	2	2	2	2	2	2	2	2	999
*	CHASSIS RETAINER	61826400	1	1	1	1	1	1	1	1	1	1	1	999
*	FRIEDRICH SCRIPT	60169105	1	1	1	1	1	1	1	1	1	1	1	999
*	PUSHNUTS, SCRIPT	91002900	2	2	2	2	2	2	2	2	2	2	2	999
*	FRIEDRICH SCRIPT	60169103					1							999
*	ACCESSORY PKGE.	61105005			1	1	1	1	1	1	1	1		999
40	WINGBOARD	60294409			1	1	1	1	1	1	1	1		999
*	HARDWARE (SCREWS)	60846017	1	1									1	999
*	HARDWARE (SCREWS)	60846016			1	1	1	1	1	1	1	1		999
45	GASKET, CHASSIS	61717301	1	1	1	1	1	1	1	1	1	1	1	780
45	GASKET, WINDOW	60073300			1	1	1	1	1	1	1	1		780
46	GASKET, VINYL	60610303			1	1	1	1	1	1	1	1		780
*	CARTON, SHIPPING	61839803							1	1	1			999
*	CARTON, SHIPPING	61839804	1	1	1	1	1	1	1				1	999
*	PAD, SHIPPING TOP	61839600	1	1	1	1	1	1	1	1	1	1	1	999
*	PAD, FRONT SUPPORT	61839700	1	1	1	1	1	1	1	1	1	1	1	999
*	PAD, SHIPPING	61839900	2	2	2	2	2	2	2	2	2	2	2	999
*	PAD, SHIPPING	61839500			1	1	1	1	1	1	1	1		999
*	PAD, SHIPPING	61840001	1	1									1	999
41	BRACKET, SUPPORT	61109503			2	2	2	2	2	2	2	2		999
43	ANGLE, TOP SUPPORT	61819701			1	1	1	1	1	1	1	1		999
42	ANGLE, WINGBOARDS	61819803			2	2	2	2	2	2	2	2		999
OPTIONAL ACCESSORIES														
*	ACCESSORY PKGE.	WIKM	1	1									1	
*	DRAIN KIT, DC-2	01900235	1	1	1	1	1	1	1	1	1	1	1	
*	START KIT, CAP.RELAY	61008903	1	1	1	1	1	1	1	1	1	1	1	
*	REMOTE CONTROLLER	61826602										1		
*	PARTS MANUAL	92013200	1	1	1	1	1	1	1	1	1	1	1	
*	SERVICE MANUAL	92013100	1	1	1	1	1	1	1	1	1	1	1	
*	INSTALLATION BOOK	92003601	1	1	1	1	1	1	1	1	1	1	1	
*	OPERATION BOOK	92000304	1	1									1	
*	OPERATION BOOK	92000505			1	1	1							
*	OPERATION BOOK	92006102					1	1						
*	OPERATION BOOK	92009001							1	1	1			
*	QUICK REF. CARD	92004401							1	1	1			

* PARTS NOT SHOWN

**"L" Series
Large Chassis
Room Air Conditioner Section**

LARGE CHASSIS "L" SERIES CHASSIS PARTS (KL, SL, EL, & YL)



LARGE CHASSIS "L" SERIES CABINET & MOUNTING PARTS (KL, SL, EL, & YL)



LARGE CHASSIS "L" SERIES PARTS LIST

REF	DESCRIPTION	PART NO#	KL 230		SL 230			EL 230		YL 230	CODE
			KL25J30A-1	KL25J30A-A	SL24J30A-A	SL28J30A-D	SL35J30-A	EL24J35A-A	EL35J35-A	YL24J35A-B	
ELECTRICAL PARTS											
1	THERMOSTAT	61822500	1	1	1	1	1				120
1	THERMOSTAT	61822400						1	1	1	120
*	THERMOSTAT, DEF.	61350313								1	122
4	CAPACITOR	61080556	1								150
4	CAPACITOR	61080551									150
4	CAPACITOR	61080557									150
4	CAPACITOR	61080533						1			150
4	CAPACITOR	61080556								1	150
4	CAPACITOR	61080551		1	1			1			150
4	CAPACITOR	61080564					1				150
4	CAPACITOR	61080567				1					150
5	SUPPLY CORD	60500049	1	1	1	1					220
5	SUPPLY CORD	60500048									220
5	SUPPLY CORD	60500055					1	1	1	1	220
3	RESISTOR BLOCK	61808001	1	1	1	1	1	1	1	1	200
6	SWITCH	60607203	1	1	1	1	1				130
6	SWITCH	60607204						1	1	1	130
7	SWITCH (YES - NO)	61806102	1	1	1	1	1	1	1	1	132
8	FAN MOTOR	61871485	1								110
8	FAN MOTOR	61871434					1				110
8	FAN MOTOR	61871435		1	1	1		1	1	1	110
*	SOLENOID COIL	25063600								1	240
8A	HEATER	61878602						1	1	1	210
REFRIGERATION SYSTEM PARTS											
9	COMPRESSOR	61193547	1							1	600
9	COMPRESSOR	61716606		1	1			1			600
9	COMPRESSOR	61716632					1				600
9	COMPRESSOR	61716634				1					600
9	COMPRESSOR	61818702						1			600
10	EVAPORATOR COIL	62050001				1	1				400
10	EVAPORATOR COIL	61850003	1	1	1			1		1	400
10	EVAPORATOR COIL	61850004							1		400
11	CONDENSER COIL	61850209	1	1	1	1	1	1			410
11	CONDENSER COIL	61850201									410
11	CONDENSER COIL	61850202							1		410
11	CONDENSER COIL	61850203								1	410
*	DRIER, LIQUID	60308101	1	1	1	1	1	1	1		480
*	DRIER, SUCTION	61828201								1	480
*	CHECK VALVE	61824400								1	510
*	REVERSING VALVE	25018700								1	500
*	CAPILLARY TUBE (HTG)	01389985				2				1	471
*	CAPILLARY TUBE	01390005					2				471
*	CAPILLARY TUBE (CLG)	03760518								1	471
*	CAPILLARY TUBE	03760473	2	2	2			2			471
*	CAPILLARY TUBE	03760520									471
*	CAPILLARY TUBE	03760545							5		471

* PARTS NOT SHOWN

LARGE CHASSIS "L" SERIES PARTS LIST

REF	DESCRIPTION	PART NO#	KL 230		SL 230			EL 230		YL 230	CODE
			KL25J30A-1	KL25J30A-A	SL24J30A-A	SL28J30A-D	SL35J30-A	EL24J35A-A	EL35J35-A	YL24J35A-B	
12	SHROUD, CONDENSER	61807700	1	1	1	1	1	1	1	1	720
*	SHROUD, W/SUMP LRG	61807701		1	1	1	1	1			720
13	FAN BLADE, COND.	60542001	1	1	1	1	1	1	1	1	710
14	BLOWER WHEEL, EVAP.	60610602	1	1	1	1		1		1	700
14	BLOWER WHEEL, EVAP.	60610609					1		1		700
15	BRACE, COND.SHROUD	61810000	3	3	3	3	3	3	3	3	722
16	SCROLL	61818100	1	1	1	1	1	1	1	1	743
17	BLOWER FRONT	61817800	1	1	1	1	1	1	1	1	742
*	INSULATION, L\IS LRG	61817600	1	1	1	1	1	1			781
*	INSULATION, L\IS	61818300	1	1	1	1	1	1	1	1	781
20	INSULATION, TOP	61818201	1	1	1	1	1	1	1	1	781
*	INSULATION, INNERWALL	61816902	1	1	1	1	1	1	1	1	781
18	INNER WALL	61907100	1	1	1	1	1	1	1	1	777
19	TOP COVER	61906600	1	1	1	1	1	1	1	1	746
21	DECK	61818000	1	1	1	1	1	1	1	1	745
22	AIR FOIL	61820201	1	1	1	1	1	1	1	1	744
24	SHIELD, BOTTOM	61813501						1		1	999
24	SHIELD, BOTTOM	61813502							1		999
26	SHIELD, SIDE	61821900						1	1	1	999
25	BRACKET, HTR	61818900						1	1	1	999
27	BASE PAN	61807101	1		1	1	1				730
27	BASE PAN	61807104		1							730
27	BASE PAN	61809501							1	1	730
27	BASE PAN	61809503						1			730
*	BELLOWS, DRAIN VALVE	60179900						1	1	1	801
*	DRAIN PAN, EVAP.	61807400	1	1	1	1	1	1	1	1	840
*	GRILLE, REAR	61818802	1	1	1	1	1	1	1	1	771
28	DOOR, SLIDE ASY	61821500	1	1	1	1	1	1	1	1	810
*	CONNECTOR SLIDE ASY	61814801	1	1	1	1	1	1	1	1	811
*	WIRE CLIP, SLIDE ASSY	60301800	2	2	2	2	2	2	2	2	999
29	PANEL, CTRL. MOUNT	61806900	1	1	1	1	1	1	1	1	999
*	PANEL, L\IS	61906800	1	1	1		1	1	1	1	999
*	PANEL, L\IS	61906802				1					999
*	PANEL, L\IS LRG	61937000		1	1	1	1	1			999
31	PARTITION, CTRL. BOX	61807000	1	1	1	1	1				999
31	PARTITION, CTRL. BOX	61807001						1	1	1	999
30	BRACKET, CAP.MOUNT	61820400	1	1	1	1	1	1	1	1	999
*	STRAP, CAP.	61820702				1	1				999
*	STRAP, CAP.	61820700	1	1	1			1	1	1	999
32	DECORATIVE PANEL	61822600	1	1	1	1	1				999
32	DECORATIVE PANEL	61823300						1	1	1	999
33	KNOBS, CRTL.	61493905	2	2	2	2	2	2	2	2	761
*	BRACKET, RESISTOR BLK	61820600	1	1	1	1	1	1	1	1	999
23	MOUNT, FAN MOTOR	61806700	1	1	1	1	1	1	1	1	900
*	HARNESS, FAN MOTOR	61820800	1	1	1	1	1	1	1	1	999
*	HOLDER, AIR FILTER	61823000	2	2	2	2	2	2	2	2	756
*	FILTER, AIR	60865810	1	1	1	1	1	1	1	1	754
*	CLAMP, SUPPLY CORD	91500301	1	1	1	1					999
*	CLAMP, SUPPLY CORD	91500302				1		1	1	1	999
34	GROMMET, COMP.	01150934	3	3	3	3	3	3	3	3	790
35	SCREW, COMP.	91400400	3	3	3	3	3	3	3	3	999
*	RETAINER, CHASSIS	61826400	1	1	1	1	1	1	1	1	999
*	COUNTER WEIGHT	61715800	2	2	2	2	2	2	2	2	999
*	GROMMET, SUCTION L.N.	61807601	1	1	1	1	1	1	1	1	999

* PARTS NOT SHOWN

LARGE CHASSIS "L" SERIES PARTS LIST

REF	DESCRIPTION	PART NO#	KL 230		SL 230			EL 230		YL 230	CODE
			KL25J30A-1	KL25J30A-A	SL24J30A-A	SL28J30A-D	SL35J30-A	EL24J35A-A	EL35J35-A	YL24J35A-B	
36	PLENIUM ASLY.	61810500	1	1	1	1	1	1	1	1	753
37	GRILLE, INTAKE	61810400	1	1	1	1	1	1	1	1	772
*	LATCH, GRILLEINTAKE	61819900	2	2	2	2	2	2	2	2	772
38	OUTER SHELL	61825702	1	1	1	1	1	1	1	1	770
39	SILL PLATE	61808401	1	1	1	1	1	1	1	1	999
*	CHASSIS GUIDE, SHELL	61819601	2	2	2	2	2	2	2	2	999
*	CHASSIS RETAINER	61826400	1	1	1	1	1	1	1	1	999
*	FRIEDRICH SCRIPT	60169105	1	1	1	1	1	1	1	1	999
*	PUSHNUTS, SCRIPT	91002900	2	2	2	2	2	2	2	2	999
*	ACCESSORY PKGE.	61105003	1	1	1	1	1				999
40	WINGBOARD	60294410	1	1	1	1	1				999
*	HARDWARE (SCREWS)	60846016	1	1	1	1	1				999
*	HARDWARE (SCREWS)	60846017						1	1	1	999
45	GASKET, CHASSIS	61717301	1	1	1	1	1	1	1	1	780
45	GASKET, WINDOW	60073300	1	1	1	1	1				780
44	GASKET, VINYL	60610303	1	1	1	1	1				780
*	CARTON, SHIPPING	61839806	1	1	1	1	1	1	1	1	999
*	PAD, SHIPPING TOP	61839601	1	1	1	1	1	1	1	1	999
*	PAD, FRONT SUPPORT	61839701	1	1	1	1	1	1	1	1	999
*	PAD, SHIPPING	61839501	1	1	1	1	1	1	1	1	999
*	SUPPORT, SHIPPING	61839901	2	2	2	2	2	2	2	2	999
*	SPACER, SHIPPING	61915100	2	2	2	2	2	2	2	2	999
41	BRACKET, SUPPORT	61109503	2	2	2	2	2				999
43	ANGLE, TOP SUPPORT	61819703	1	1	1	1	1				999
42	ANGLE, WINGBOARDS	61819805	2	2	2	2	2				999
OPTIONAL ACCESSORIES											
*	ACCESSORY PKGE.	WIKL						1	1	1	
*	DRAIN KIT, DC-2	01900235	1	1	1	1	1	1	1	1	
*	START ASSIST KIT	61008903	1	1	1	1	1	1	1	1	
*	HARD START KIT	61840900					1	1	1		
*	PARTS MANUAL	92013200	1	1	1	1	1	1	1	1	
*	SERVICE MANUAL	92013100	1	1	1	1	1	1	1	1	
*	INSTALLATION BOOK	92003601	1	1	1	1	1	1	1	1	
*	OPERATION BOOK	92000505	1	1							
*	OPERATION BOOK	92000202			1	1	1				
*	OPERATION BOOK	92000304						1	1	1	

* PARTS NOT SHOWN

"WM" Series
115 / 230 Volt
WallMaster Chassis
Room Air Conditioner Section

"WE," "WS," & "WY" SERIES CHASSIS PARTS



"WE," "WS," & "WY" SERIES DECORATIVE FRONT



"WM" SERIES WALLMASTER PARTS LIST

REF	DESCRIPTION	PART NO#	115V				230V	230V	230V	230V	230V	230V	230V	CODE
			WS07A10E-B	WS07A10E-C	WS10A10A	WS12A10E-A	WS09A30E-B	WS12A30E-A	WS15A30A	WE09A33E-B	WE12A33E-A	WE15A33A	WY09A33E-A	
1	THERMOSTAT	61822501	1	1	1	1	1	1					120	
1	THERMOSTAT	61822401							1	1	1	1	120	
2	THERMOSTAT, DEF.	61350313									1	1	122	
3	OVERLOAD	61764533	1										190	
3	OVERLOAD	61764516		1									190	
3	OVERLOAD	61764519			1								190	
3	OVERLOAD	61764521					1			1			190	
3	OVERLOAD	61764532						1			1		190	
3	OVERLOAD	61764535				1							190	
3	OVERLOAD	61764528				1							190	
3	OVERLOAD	61578001							1			1	190	
3	OVERLOAD	60364596											190	
3	OVERLOAD	60364597											190	
4	CAPACITOR	61080554	1										150	
4	CAPACITOR	61080535		1	1								150	
4	CAPACITOR	61080539											150	
4	CAPACITOR	61080562				1							150	
4	CAPACITOR	61080540					1			1		1	150	
4	CAPACITOR	61080565						1	1		1	1	150	
5	SUPPLY CORD	60500060	1	1	1								220	
5	SUPPLY CORD	60500061				1							220	
5	SUPPLY CORD	60500062					1	1	1				220	
5	SUPPLY CORD	60500063								1	1	1	220	
6	SWITCH	60607203	1	1	1	1	1	1					130	
6	SWITCH	60607204								1	1	1	130	
7	FAN MOTOR	61071453	1	1	1								110	
7	FAN MOTOR	61071452				1							110	
7	FAN MOTOR	61071454					1			1		1	110	
7	FAN MOTOR	61071451						1	1		1	1	110	
8	HEATER	61580802								1	1	1	210	
9	COIL, SOLENOID	21058643										1	240	
REFRIGERATION SYSTEM PARTS														
10	REVERSING VALVE	25018300										1	1	
11	CHECK VALVE	61824400										1	1	
*	FILTER DRIER	60308101	1	1	1	1	1	1	1	1	1	1	480	
*	SUCTION DRIER	61828200	1	1	1	1	1	1	1	1	1	1	480	
12	COMPRESSOR	61562805							1				600	
12	COMPRESSOR	61562803										1	600	
12	COMPRESSOR	61562804						1					600	
12	COMPRESSOR	61716638					1			1			600	
12	COMPRESSOR	61716639	1										600	
12	COMPRESSOR	61716605		1									600	
12	COMPRESSOR	61716622			1								600	
12	COMPRESSOR	61716628								1			600	
12	COMPRESSOR	61716631							1		1		600	
12	COMPRESSOR	61716633				1		1					600	
13	EVAPORATOR COIL	61600221	1	1									400	
13	EVAPORATOR COIL	61600218										1	400	
13	EVAPORATOR COIL	61600219								1			400	
13	EVAPORATOR COIL	61600246											400	
13	EVAPORATOR COIL	62050000				1		1			1		400	
13	EVAPORATOR COIL	62050002			1		1		1				400	
14	CONDENSER COIL	61850309	1										410	
14	CONDENSER COIL	61850308			1			1			1		410	
14	CONDENSER COIL	61850210											410	
14	CONDENSER COIL	61600512										1	410	
114	CONDENSER COIL	61600513											410	
14	CONDENSER COIL	62050200				1					1		410	
14	CONDENSER COIL	62050202		1			1		1				410	
15	CAPILLARY TUBE	01389903			1								471	
15	CAPILLARY TUBE	03760518					1			1			471	
15	CAPILLARY TUBE	03760545				1							471	
15	CAPILLARY TUBE	03760520											471	
15	CAPILLARY TUBE	03760550											471	
15	CAPILLARY TUBE(HTG)	03760543	1	1					2		2	1	471	
15	CAPILLARY TUBE(CLG)	03760547						1			1		471	
15	CAPILLARY TUBE(HTG)	03760482											471	
15	CAPILLARY TUBE(CLG)	03760558										1	471	

* PARTS NOT SHOWN

"WM" SERIES WALLMASTER PARTS LIST

REF	DESCRIPTION	PART NO#	115V				230V	230V	230V	230V	230V	230V	230V	230V	CODE
			WS07A10E-B	WS07A10E-C	WS10A10A	WS12A10E-A	WS09A30E-B	WS12A30E-A	WS15A30A	WE09A33E-B	WE12A33E-A	WE15A33A	WY09A33E-A	WY12A33F-A	
16	SHROUD, CONDENSER	61602700	1	1	1	1	1	1	1	1	1	1	1	720	
17	FAN BLADE, COND.	60542002	1	1	1	1	1	1	1	1	1	1	1	710	
18	BLOWER WHEEL, EVAP.	60610604	1	1		1								700	
18	BLOWER WHEEL, EVAP.	60415205			1		1	1						700	
18	BLOWER WHEEL, EVAP.	60610611				1								700	
18	BLOWER WHEEL, EVAP.	60415204						1			1			700	
18	BLOWER WHEEL, EVAP.	60415203							1	1		1	1	700	
19	BLOWER FRONT	61657100	1	1		1								742	
19	BLOWER FRONT	61603700			1		1	1	1					742	
19	BLOWER FRONT	61612400							1	1	1	1	1	742	
20	INNER WALL	61605100	1	1	1	1	1	1	1				1	777	
20	INNER WALL	61605101							1	1	1	1	1	777	
21	BLOWER WRAPPER	61022507	1	1	1	1	1	1	1	1	1	1	1	741	
22	COVER, BULKHEAD	61605800	1	1	1	1	1	1	1	1	1	1	1	746	
23	DECK ASSLY	61605600	1	1	1	1	1	1	1	1	1	1	1	745	
24	COVER,SHROUD & BRACE	61604400	1	1	1	1	1	1	1	1	1	1	1	999	
25	BASE PAN ASLY.	61606201	1											730	
25	BASE PAN ASLY.	61606203		1	1	1	1	1	1					730	
25	BASE PAN ASLY.	61606205							1	1	1	1	1	730	
26	BELLOWS,DRAIN V ALVE	60179900							1	1	1	1	1	801	
27	DRAIN PAN, EVAP.	61602600	1	1	1	1	1	1	1	1	1	1	1	840	
28	DRAIN GASKET	61603900	1	1	1	1	1	1	1	1	1	1	1	800	
29	DRAIN PLATE	61604000	1	1	1	1	1	1	1	1	1	1	1	800	
30	RETAINER CUP ,FAN MTR	60640600	3	1	3	3	3	3	3	3	3	3	3	771	
331	GROMMET,FAN MTR	60640500	3	3	3	3	3	3	3	3	3	3	3	790	
32	NUT,FAN MTR	91003000	3	3	3	3	3	3	3	3	3	3	3	999	
33	DOOR, EXHAUST ASLY	61358301	1	1	1	1	1	1	1	1	1	1	1	810	
34	DOOR, SPRING	61613600	1	1	1	1	1	1	1	1	1	1	1	810	
35	LINK, EXHAUST DOOR	61358401	1	1	1	1	1	1	1	1	1	1	1	810	
36	HINGE PIN	61610400	1	1	1	1	1	1	1	1	1	1	1	810	
37	SLIDE, EXHAUST DOOR	61656201	1	1	1	1	1	1	1	1	1	1	1	810	
38	CHANNEL,EXHAUST DOOR	61656200	1	1	1	1	1	1	1	1	1	1	1	810	
39	PANEL, CTRL. MOUNT	61757800	1	1	1	1	1	1	1	1	1	1	1	999	
40	PANEL, L/S	61604600	1	1	1	1	1	1	1	1	1	1	1	999	
41	PANEL, CTRL. BOX	61605404	1	1	1	1	1	1	1	1	1	1	1	999	
42	FRONT PANEL	61610100	1	1	1	1	1	1	1	1	1	1	1	760	
43	DECORATIVE PANEL	61750102	1	1	1	1	1	1	1					760	
43	DECORATIVE PANEL	61750202							1	1	1	1	1	760	
44	KNOBS, CRTL.	61911600	2	2	2	2	2	2	2	2	2	2	2	761	
*	HOLDER, AIR FILTER	60865900	1	1	1	1	1	1	1	1	1	1	1	764	
45	HOLDER, THERMOSTAT	61715100	1	1	1	1	2	2	2	2	2	2	2	764	
45	FILTER, AIR	60865805	1	1	1	1	1	1	1	1	1	1	1	754	
*	FRONT, DECORATIVE	61607002	1	1	1	1	1	1	1	1	1	1	1	750	
46	FRAME, HOOD	61612601	1	1	1	1	1	1	1	1	1	1	1	750	
47	GRILLE, INTAKE	61612703	1	1	1	1	1	1	1					750	
47	GRILLE, INTAKE	61612702								1	1	1	1	750	
48	GRILLE, EXHAUST	61612800	1	1	1	1	1	1	1	1	1	1	1	750	
49	LOUVER	61612900	12	12	12	12	12	12	12	12	12	12	12	750	
50	LOUVER, W/HANDLE	61912901	2	2	2	2	2	2	2	2	2	2	2	750	
51	BAR, CONNECTOR	61613000	2	2	2	2	2	2	2	2	2	2	2	750	
52	DOOR, CTRL.	61613100	1	1	1	1	1	1	1	1	1	1	1	750	
53	END CAP, GRILLE	61613200	1	1	1	1	1	1	1	1	1	1	1	750	
54	BUTTON, SLIDE EXHAUST	61638900	1	1	1	1	1	1	1	1	1	1	1	999	
*	BUTTON SLIDE PEARL	61911700	1	1	1	1	1	1	1	1	1	1	1		
*	COUNTER WEIGHT	61715800	2	2	2	2	2	2	2	2	2	2	2		

* PARTS NOT SHOWN

"WM" SERIES WALLMASTER PARTS LIST

REF	DESCRIPTION	PART NO#	115V				230V	230V	230V	230V	230V	230V	230V	230V	CODE
			WS07A10E-B	WS07A10E-C	WS10A10A	WS12A10E-A	WS09A30E-B	WS12A30E-A	WS15A30A	WE09A33E-B	WE12A33E-A	WE15A33A	WY09A33E-A	WY12A33F-A	
*	HARDWARE, SCREWS	60846014	1	1	1	1	1	1	1	1	1	1	1	999	
*	GASKET, CHASSIS	61717301	1	1	1	1	1	1	1	1	1	1	1	780	
*	CARTON, SHIPPING	61608401	1	1	1	1	1	1	1	1	1	1	1	999	
*	CARTON, WALL SLEEVE	61630606	1	1	1	1	1	1	1	1	1	1	1	999	
*	PAD, SHIPPING	61624604	1	1	1	1	1	1	1	1	1	1	1	999	
*	INSERT, SHIPPING	61624901	1	1	1	1	1	1	1	1	1	1	1	999	
*	SUPPORT, SHIPPING	61624701	1	1	1	1	1	1	1	1	1	1	1	999	
OPTIONAL ACCESSORIES															
*	START KIT	61008903	1	1	1	1	1	1	1	1	1	1	1	160	
*	PARTS MANUAL	92013200	1	1	1	1	1	1	1	1	1	1	1	999	
*	SERVICE MANUAL	92013100	1	1	1	1	1	1	1	1	1	1	1	999	
55	SLEEVE (ONLY)	61603601	1	1	1	1	1	1	1	1	1	1	1	770	
56	INNER WEATHER PANEL	61603200	1	1	1	1	1	1	1	1	1	1	1	999	
*	GRILLE, STAMPED	61603001	1	1	1	1	1	1	1	1	1	1	1	771	
58	OUTER WEATHER PANEL	61603301	1	1	1	1	1	1	1	1	1	1	1	999	
*	FRIEDRICH SCRIPT	60405804	1	1	1	1	1	1	1	1	1	1	1	999	

* PARTS NOT SHOWN

