

**6  
VOLT**

# CHOO CHOO express train

Model Number IGEDI116

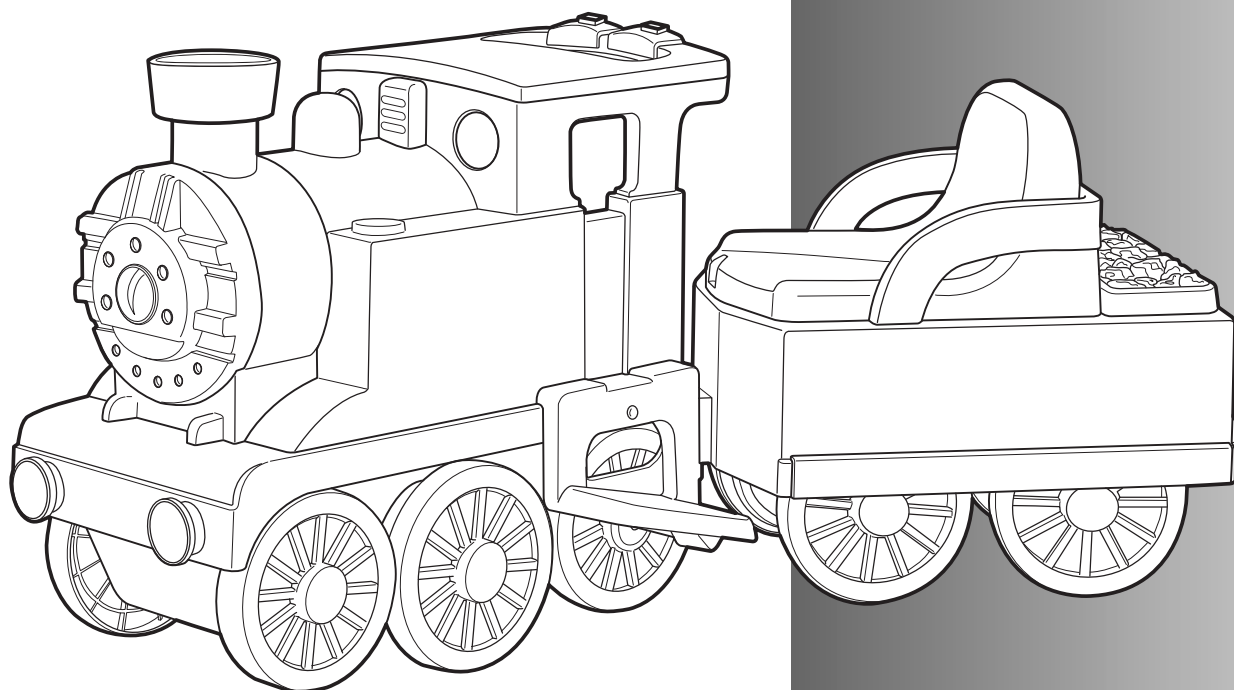

**Peg-Pérego**

made in USA

USE AND CARE **EN**

EMPLOY Y MANUTENCION **ES**

UTILISATION ET ENTRETIEN **FR**

See separate insert  
sheet for more  
information

Vea la hoja separada del  
separador de millares  
para más información

Voir la feuille séparée  
d'insertion pour plus  
d'information



**2 YEARS\***

\*CONSUMER PARTICIPATION  
REQUIRED

FIUS090IG131



SEE VERBAL INSTRUCTIONS  
AFTER THE PICTURES

VER LAS INSTRUCCIONES  
DESPUÉS DE LOS DISEÑOS

VOIR LES INSTRUCTIONS  
APRÈS LES DESSINS

INITIAL BATTERY CHARGE

PRIMERA CARGA DE LA  
BATERÍA

PREMIÈRE CHARGE DE  
BATTERIE

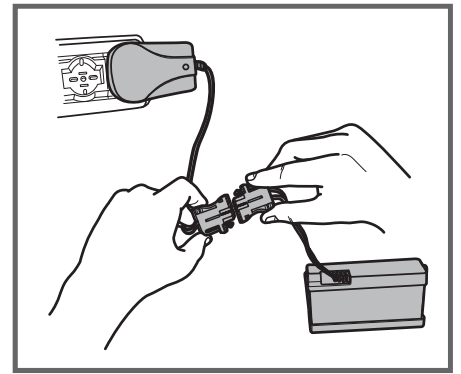

ASSEMBLY

MONTAJE

MONTAGE

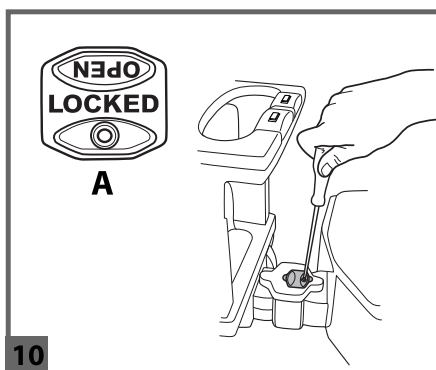
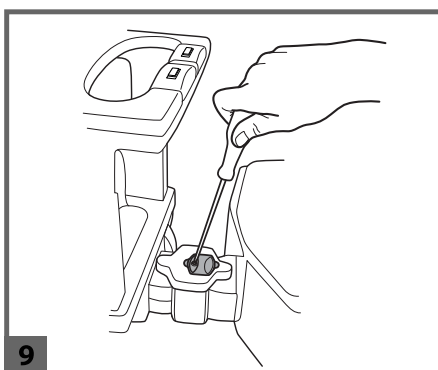
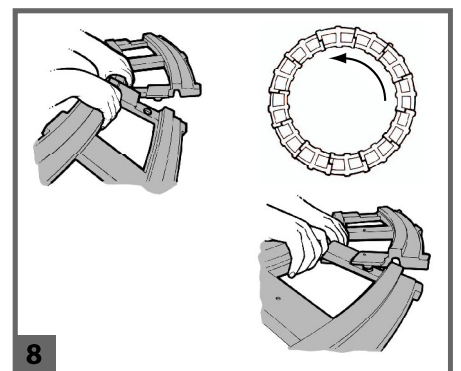
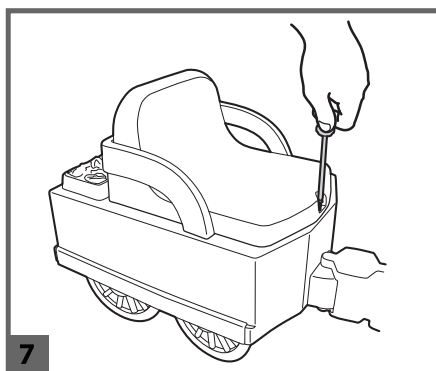
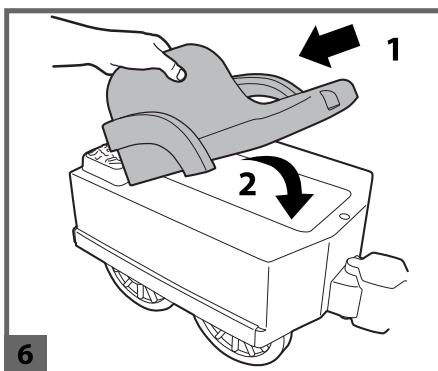
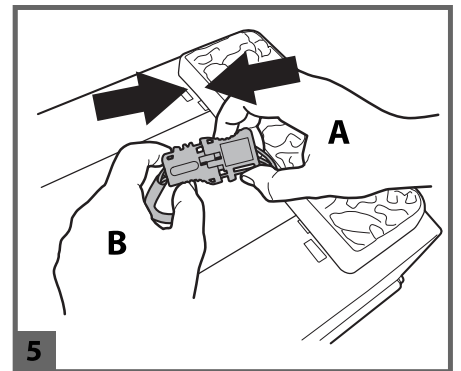
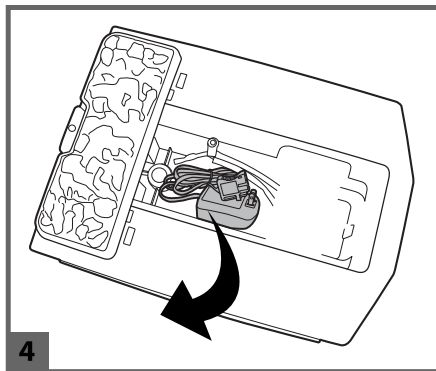
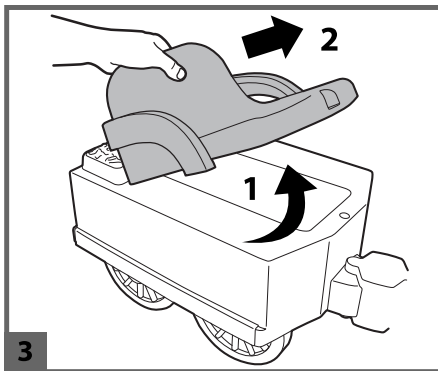
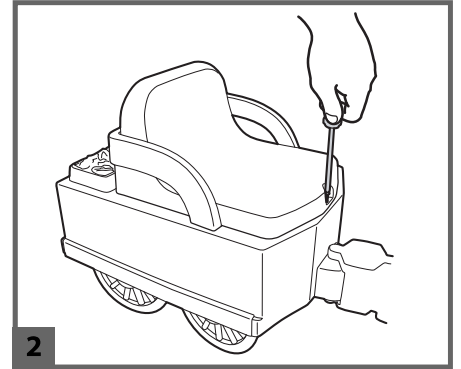
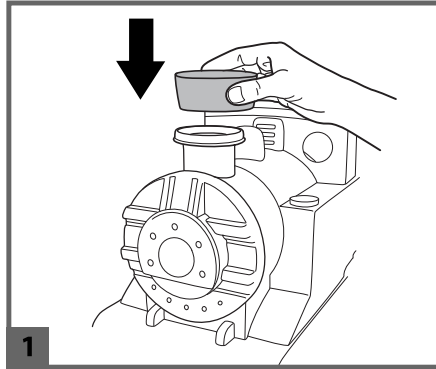

FEATURES AND  
INSTRUCTIONS FOR USE

CARACTERÍSTICAS Y USO

CARACTÉRISTIQUES ET  
UTILISATION

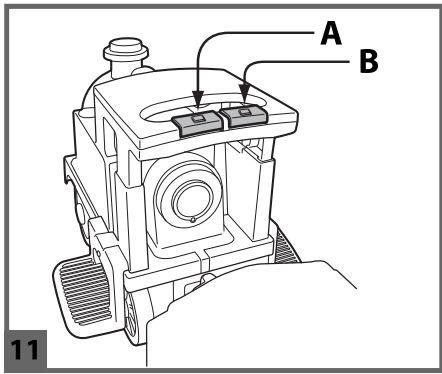

11

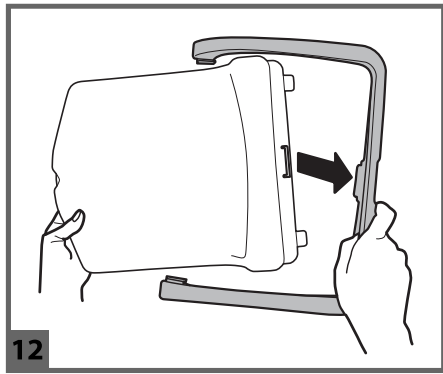

12

OPTION  
OPCIONAL  
OPTION

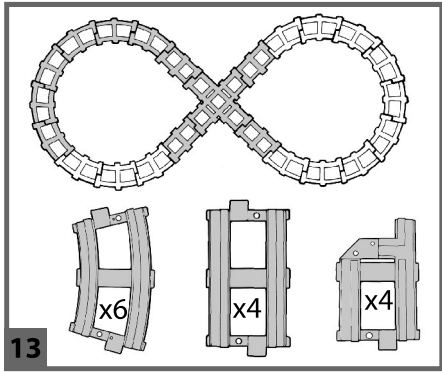

13

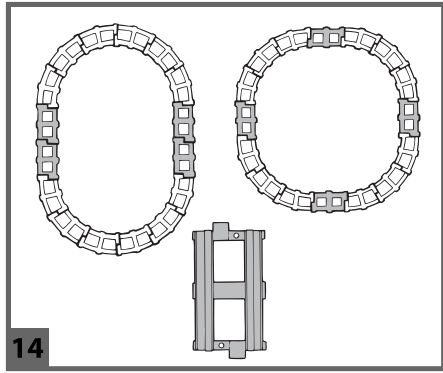

14

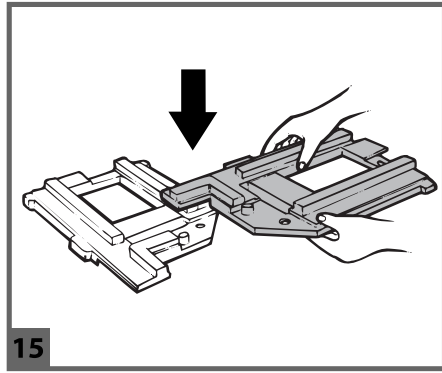

15

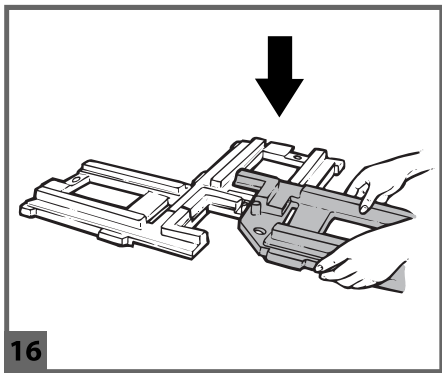

16

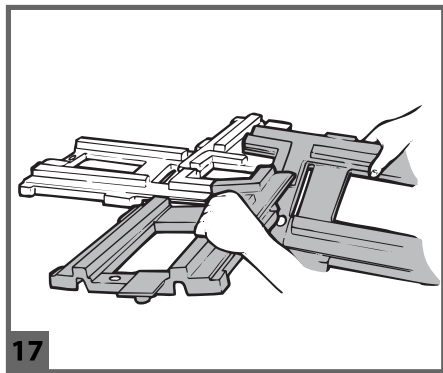

17

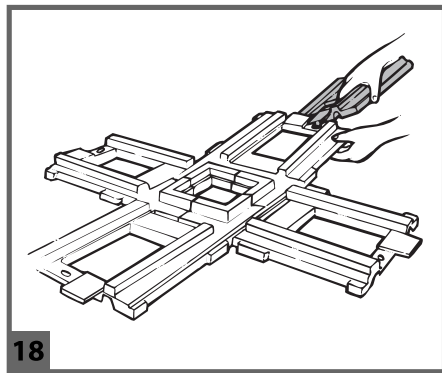

18

BATTERY REPLACEMENT  
CAMBIO DE LA BATERÍA  
REPLACEMENT DE LA BATTERIE

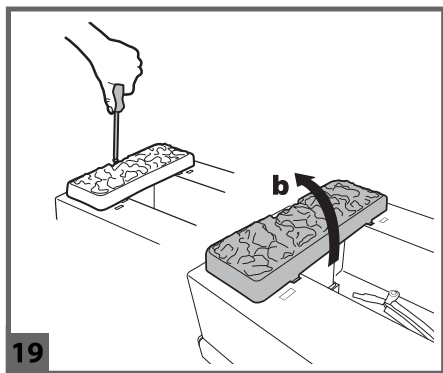

19

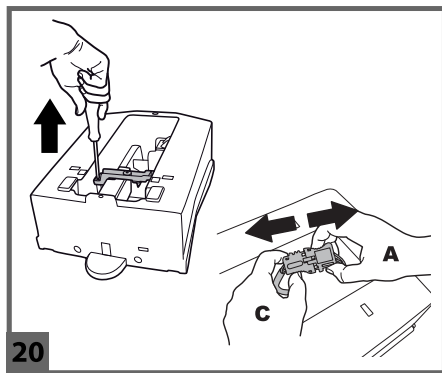

20

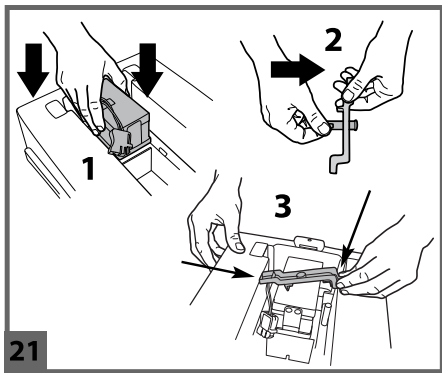

21

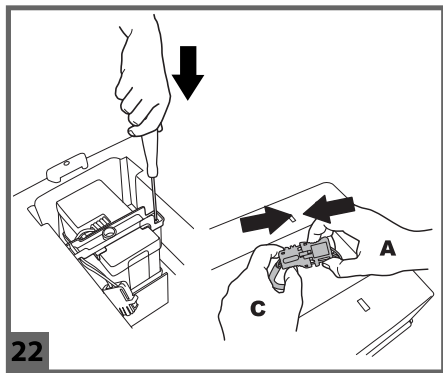

22

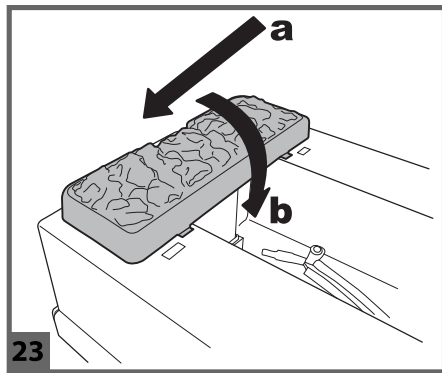

23

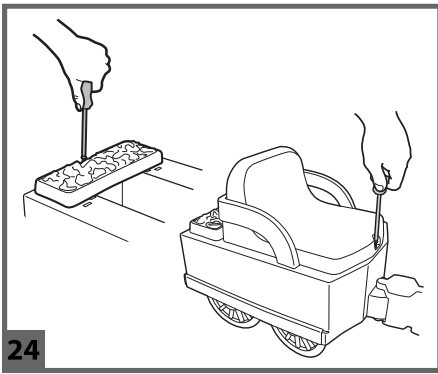

24

**BATTERY RECHARGE**  
**CARGA DE LA BATERÍA**  
**CHARGE DE LA BATTERIE**

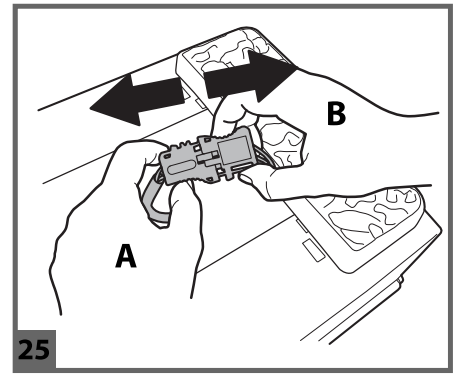

25

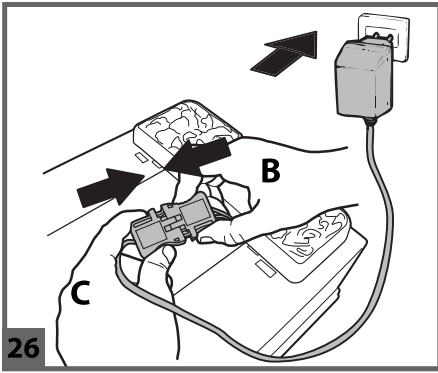

26

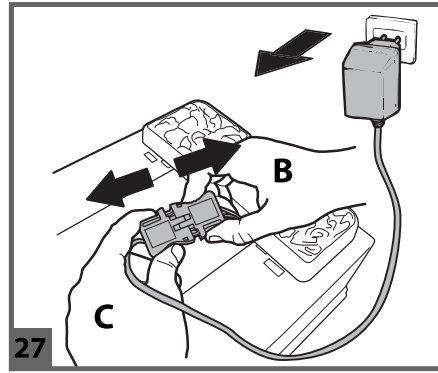

27

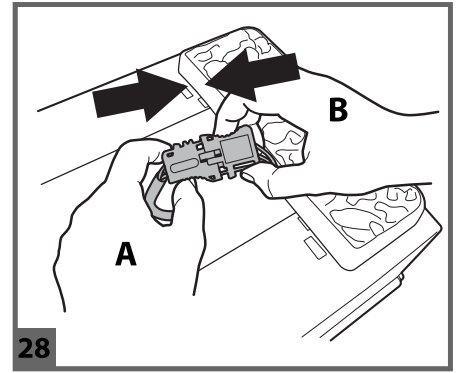

28

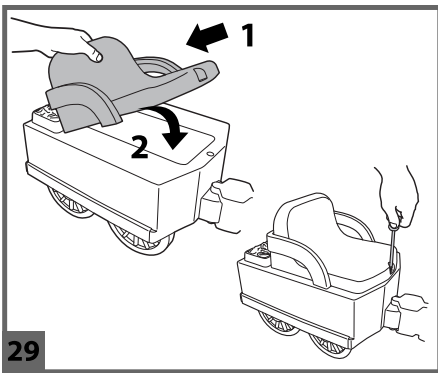

29

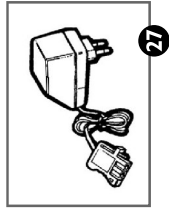

27

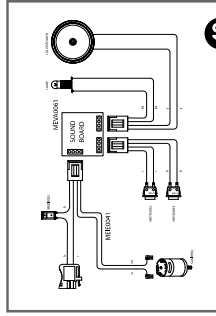

40

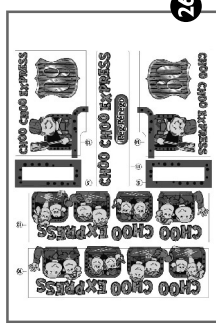

26

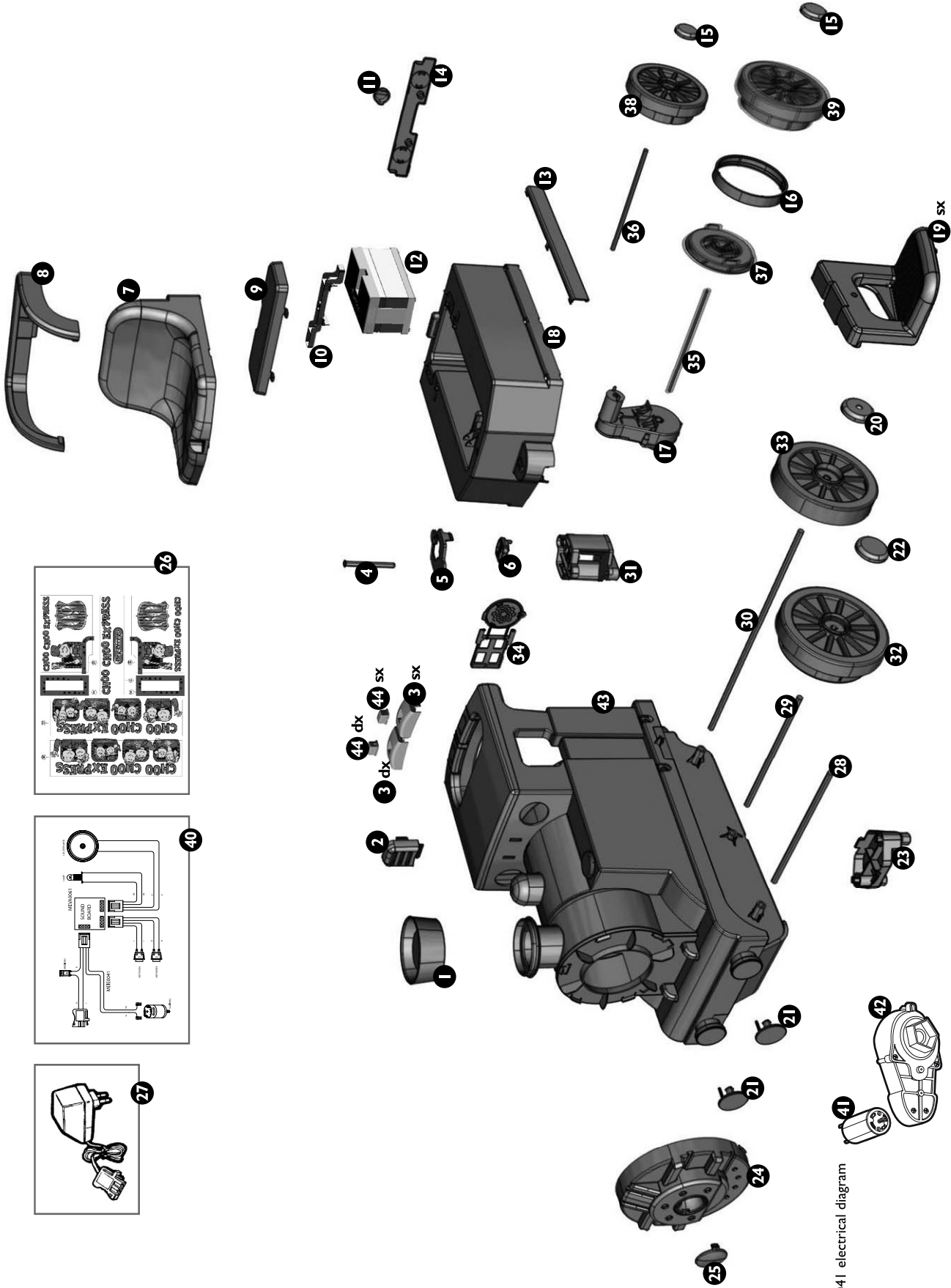

- 1 SPST9168YY
- 2 SPST9111GR
- 3 dx SPST8532KDYY
- 3 sx SPST8532KSYY
- 4 MMRP0990
- 5 SPST8588|GP
- 6 SPST907|IR
- 7 SPST8512GR
- 8 SPST8513R
- 9 SPST8514GP
- 10 SPST9128GL
- 11 SPST8517YY
- 12 IAKB0022
- 13 SPST8516GR
- 14 SPST8515GR
- 15 SPST852|GP
- 16 SPST854|IN
- 17 SAGI9963|K|TBN
- 18 SPST8511|JR
- 19 dx SPST8518DGR
- 19 sx SPST8518SGR
- 20 SPST8644GP
- 21 SPST8538YY
- 22 SPST852|GP
- 23 ASGI0169GP
- 24 SPST9072GR
- 25 SPST8535|J
- 26 MMEV0622
- 27 IKCB...
- 28 SOFF0214Z
- 29 SOFF0214Z
- 30 SOFF0215Z
- 31 SPST8537|GP
- 32 SPST8519YY
- 33 SPST8536YY
- 34 SPST8589N
- 35 SOFF0214Z
- 36 SOFF0214Z
- 37 SPST8520YY
- 38 SPST8519YY
- 39 SPST8519YY
- 40 MEVA0061 + MEIE004 | electrical diagram
- 41 SAGI9992
- 42 SAGI3635W|K|B
- 43 ASGI0170GPR
- 44 dx SPST9196N
- 44 sx SPST9196R

PEG PEREGO® thanks you for choosing this product. For almost 60 years, PEG PEREGO has been taking children for outings: first with its famous baby carriages and strollers, later with its pedal and battery operated toy vehicles.

Discover our complete range of products, news and other information about the Peg Perego world on our web site [www.pegperego.com](http://www.pegperego.com)

## IMPORTANT INFORMATION

- Read this instruction manual carefully to learn the use of the toy and to teach your child safe and enjoyable driving. Please keep this manual (with your original sales receipt) for use as a reference in the future.
- **DO NOT RETURN YOUR TOY TO THE STORE. This product cannot be returned for a refund after it has been used. If you have ANY questions, need replacement parts or need assistance, call us toll-free; U.S.A. , call 1-800-728-2108 / CANADA, call 1-800-661-5050**
- This product meets and/or exceeds all ASTM (American Society for Testing and Materials) TOY SAFETY STANDARDS, including F 963, Consumer Toy Safety Specifications as well as C.R.C, c.931, the Canadian Hazardous Products (Toys) Regulations.
- Tools needed for assembly: small and medium phillips screwdrivers and a hammer.
- Your new toy is partially pre-assembled. It will require adult assembly. Please set aside 15-20 minutes for assembly.
- Before the toy is used for the first time, charge the battery for 18 hours to initiate it. Failure to do this can result in permanent battery damage.
- Use only with the included Peg Perego 6 Volt lead-acid, rechargeable battery and a Peg Perego 6 Volt Charger (both included).

- **Year 1-3**
- **Weight capacity 40 lbs**

- Do not exceed the maximum total weight capacity of 40 lbs (18,1Kg).

### Contents:

- 1 Choo Choo Express Train riding toy -- partially assembled
- 1 Rechargeable 6V 3,3Ah sealed lead-acid battery
- 1 Charger 6V
- one 60W motor -- pre installed
- assembly hardware
- parts to be assembled
- decals

- Speed: 1,5 mph

- Peg Perego reserves the right to modify or change its products. Price, literature, manufacturing processes or locations or any combination of the above mentioned entities may change at any time for any reason without notice with impunity.

## CAUTION:

ELECTRIC TOY NOT RECOMMENDED FOR CHILDREN UNDER 1 YEAR OF AGE. AS WITH ALL ELECTRIC PRODUCTS, PRECAUTIONS SHOULD BE OBSERVED DURING HANDLING AND USE TO PREVENT ELECTRIC SHOCK. RECHARGER INCLUDED. 120 VOLTS, 60Hz, 15W INPUT, 6 VOLTS (DC) OUTPUT.



## **⚠ CAUTION:**

Only adults should recharge batteries never children.

Never allow children to handle batteries.

Only use the batteries specified by the manufacturer. Only use the charger specified by the manufacturer.

Do not mix old and new batteries.

Do not mix alkaline, standard (carbon-zinc), or rechargeable (nickel-cadmium) batteries.

### CHARGING THE BATTERY

- Charge the batteries no longer than 24 hours, following the instructions enclosed with the battery charger.
- Charge the battery, as the toy shows low power; in this way you will avoid damage to the battery.
- If you don't use your toy for a long period of time unplug the battery from the main wire harness of the toy. Remember to charge the battery at least every three months.
- Never charge the battery upside down.
- Do not forget batteries during charging! Check them periodically.
- Never use a replacement recharger or batteries unless they are approved by PEG PEREGO.
- Batteries are sealed and maintenance free.
- Battery polarity must be observed when connecting battery to wiring.

## **⚠ WARNING:**

- BATTERIES CONTAIN TOXIC AND CORROSIVE SUBSTANCES. DO NOT TAMPER WITH THEM.
- Batteries contain an acid-based electrolyte.
- Do not make direct contact between battery terminals, as this can cause an explosion or fire.
- Charging produces explosive gases. Charge batteries in a well ventilated area away from sources of heat and flammable materials.
- Exhausted batteries are to be removed from the toy.
- Do not place the batteries near clothing to avoid damage.

### IF A LEAK DEVELOPS

Shield your eyes. Avoid direct contact with the electrolyte, protect your hands.

Place battery in a plastic bag and follow directions listed below.

### IF ELECTROLYTE COMES IN CONTACT WITH SKIN OR CLOTHING

Flush with cool water for at least 15 minutes.

See a physician at once.

### IF ELECTROLYTE IS INJECTED

Give tap water, milk of magnesia or egg whites at once.

Do not induce vomiting.

See a physician at once.

### DISPOSAL OF BATTERIES

Help protect the environment!

Do not throw used batteries in your regular, household trash.

Dispose of the old batteries in an approved dumping station; contact your local environmental protection agency office for further information.



## INITIAL BATTERY CHARGE

- !• Remove battery and charger from packaging. Connect battery charger to a 120vac wall recepticle. Connect battery charger to battery.

## ASSEMBLY INSTRUCTIONS

### **WARNING:**

ADULT ASSEMBLY REQUIRED. USE CARE WHEN UNPACKING AS COMPONENTS TO BE ASSEMBLED MAY POSE A SMALL PARTS/SHARP EDGE HAZARD.  
BATTERY ALREADY INSTALLED IN VEHICLE.

- 1 • Snap-fit the end of the funnel, which is included in the packaging.
- 2 • Loosen the screw on the front of the seat.
- 3 • Remove the seat by lifting the front part (1) and pulling out the back part (2).
- 4 • Remove the battery charger from the compartment under the seat.
- 5 • Connect the battery plug (A) to the system plug (B).
- 6 • Put the seat back into place, inserting the back part first (1) and then the front part (2).
- 7 • Fasten the seat with the screw. The vehicle is ready for use.
- 8 • The product can operate both with and without the track. Assemble the track as shown in the figure. For best results, position the train on the track so that it travels anticlockwise.
- 9 • To use the train off the track, remove the screw on the coupling lock as shown in the figure.
- 10 • Turn the lock around and put it back, as shown in detail A of the figure. Secure the lock with the screw. To use the product on the track again, it is necessary to return it to its original state.

## FEATURES AND INSTRUCTIONS FOR USE

- 11 • OPERATION BUTTONS: Press button A to play the tunes. Press the button again to change the tune. To start the train, press button B: the headlight and the sound effects will also automatically come on.
- 12 • ARMRESTS: Pull the seat out as shown above. Unhook and remove the armrests (see figure). Put the seat back into place and fasten it with the screw.

## OPTION

- 13 • FIGURE 8 CONVERSION TRACK SET OPTION: The kit for the Figure 8 Track includes 6 bends, 4 straight pieces of track, and 4 intersections. By adding the 12 bends that come with the train, the track will make a figure eight.
- 14 • When you purchase an OPTIONAL FIGURE 8 CONVERSION TRACK SET, you can also make the OVAL FIGURE using the 4 pieces of straight track.
- 15 • To assemble the FIGURE 8 TRACK, place a piece of intersection over another piece, as shown in the figure.
- 16 • Add a second piece of track.
- 17 • To fasten the last piece of the intersection, turn the first and last piece slightly, as shown in the figure.
- 18 • Complete the track by adding the remaining pieces.

## BATTERY REPLACEMENT

### **WARNING:**

WARNING: BATTERY CHARGING AND ANY OTHER OPERATION ON THE ELECTRICAL SYSTEM MUST BE CARRIED OUT BY ADULTS ONLY.  
THE BATTERY CAN ALSO BE CHARGED WITHOUT REMOVING IT FROM THE TOY.

- 19 • Remove the seat. Loosen the screw and remove the fake coal from the back of the seat.
- 20 • Unfasten the screw fixing the battery holder and take it out. Unfasten the connectors (system-battery).
- 21 • Replace the battery (1). Remove the central peg from the battery holder, pressing the tabs at the end of the peg to do so (2). Replace the battery holder, inserting it first into one opening and then into the other (3), as shown in the figure.
- 22 • Screw the battery holder back into place. Join the two connectors.
- 23 • Put the fake coal back into place.
- 24 • Fasten the fake coal with the screw and put the seat back into place, as shown above. Fasten the seat with the screw.

## BATTERY RECHARGER

- 25 • Disconnect plug A (the electrical system plug) from plug B (the battery plug) by pressing on the sides of the plugs.
- 26 • Connect plug B to plug C (the battery charger plug). Connect the battery charger to a household electrical outlet, following the instructions supplied with the battery charger.
- 27 • When the battery is completely charged, disconnect the battery charger from the outlet and disconnect plug C from plug B.
- 28 • Connect plug B to plug A, pressing until it clicks into place.
- 29 • Always remember to put the seat back into place and to fasten it with a screw.



## RULES FOR SAFETY DRIVING

DON'T STOP THE FUN: always have freshly charged, back-up batteries on hand.

For your child's safety: please read and follow all instructions below before operating.

• **ATTENTION:**

Check the fastening retainers to be sure they are tight.

Teach your child the proper use of this toy for a safe and fun play time.

### **CAUTION:**

• **If the toy is overloaded, the overload switch will immediately disconnect the power. The power supply will be restored after a few seconds.**

## MAINTENANCE AND SAFETY

This product meets and/or exceeds all ASTM (American Society for Testing and Materials) TOY SAFETY STANDARDS, including F 963, Consumer Toy Safety Specification.

This toy is not intended for use on streets, around traffic or parked cars.

### **MAINTENANCE AND CARE**

- Regularly check the conditions of the toy, particularly the electrical system, the plug connections, the covering caps and the charger. In case of fault, do not try to use the toy and the charger. For repair use only original PEG PEREGO's spare parts.
- PEG PEREGO assumes no liability if the electrical system is tampered with.
- Do not leave toy or batteries near sources of heat such as radiators, stoves, fireplaces, etc.
- Protect toy from water, rain, snow, etc.
- When operating in overload conditions, the overload circuit breaker will automatically disconnect the power. After 10 or more seconds, the circuit breaker will automatically reset, however you must eliminate overload conditions to resume normal driving.
- Periodically lubricate (with a light weight oil) moving parts, such as wheel bearings, steering linkages, where they rotate or touch one another.
- The toy's surface can be cleaned with a dampcloth. Do not use abrasive cleaners. The cleaning must be carried out by adults only.
- Never disassemble the toy mechanisms or motor unless authorized by PEG PEREGO.

### **SAFETY**

### **WARNING:**

- To reduce the risk of injury, adult supervision is required. Never use in roadways, near motor vehicles, on or near steep inclines or steps, swimming pools or other bodies of water; always wear shoes, and never allow more than one rider.
- Surface appropriate for use: asphalt, cement, tiles and smooth surfaces.
- A child must be 1 year of age or older for the necessary coordination and maturation to operate this motorized toy safely.
- Never use the toy on steep slopes or near steps or stairs. This toy is not suitable for use on public roadways.
- Children should always wear shoes when riding in or driving a riding toy.
- Do not allow children to place their hands, feet or any part of their body, clothing or other articles near the moving parts while toy is in operation.
- Do not allow the electrical components, motors, wiring, switches of your motorized toy to become wet and never wash it with a hose.
- Never use gasoline or other flammable substances near the toy.
- The toy is designed just for one child: never allow more than one rider.

## PROBLEMS?

IF THE TOY DOES NOT OPERATE?

- **When operating in overload conditions, the circuit breaker will automatically disconnect the power. After 10 or more seconds, the circuit breaker will automatically reset, however-you must eliminate overload conditions to resume normal operating.**
- Check that all plugs are properly connected.
- Check electrical switches. Replace if necessary.
- Check that the battery is connected to the electrical system.

IF THERE IS NO POWER?

- Fully recharge the battery. If the problem persist, check with an Authorised PEG PEREGO Service Center.

## CUSTOMER SERVICE

For your convenience, PEG PEREGO offers after-sales service, directly or through a network of authorized service centers for repairs or replacement parts.

If you have any questions about your Peg Perego vehicle, please call our toll-free service lines at;

**U.S.A , call 1-800-728-2108**

**CANADA, call 1-800-661-5050**

Trained customer service representatives are available to take your call in English or Spanish.

This document was created with Win2PDF available at <http://www.win2pdf.com>.  
The unregistered version of Win2PDF is for evaluation or non-commercial use only.  
This page will not be added after purchasing Win2PDF.