

This Owner's Manual is provided and hosted by [Appliance Factory Parts](#).



FRIEDRICH KQ06J10B-B Owner's Manual

[Shop genuine replacement parts for FRIEDRICH
KQ06J10B-B](#)



[Find Your FRIEDRICH Air Conditioner Parts - Select From 1575 Models](#)

----- Manual continues below -----

Friedrich

2003 Parts Manual

Room Air Conditioners

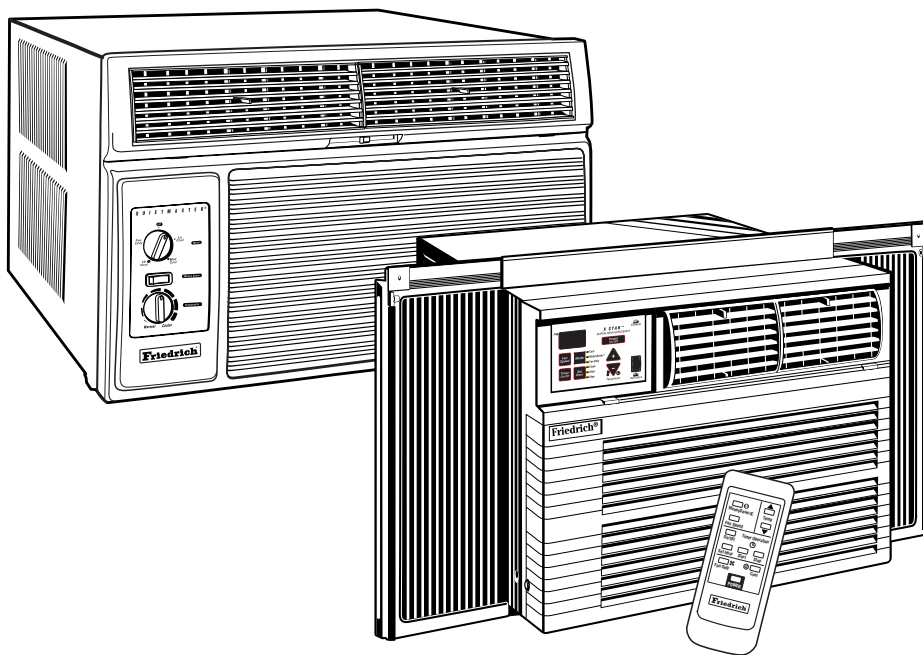

TABLE OF CONTENTS

	PAGE
PORTABLE "Q" SERIES UNITS	3-12
SMALL CHASSIS "S" SERIES UNITS (115 & 230 VOLT)	13-18
MEDIUM CHASSIS "M" SERIES UNITS (115 & 230 VOLT)	19-25
LARGE CHASSIS "L" SERIES UNITS	26-32
CASEMENT "C" SERIES UNITS (115 & 230 VOLT)	33-37

**"Q" Series
Portable Chassis
Room Air Conditioner Section**

"Q" SERIES CABINET PARTS

NOTE: Items 2, 9A, 13 and 14 are used on "YQ" units only.

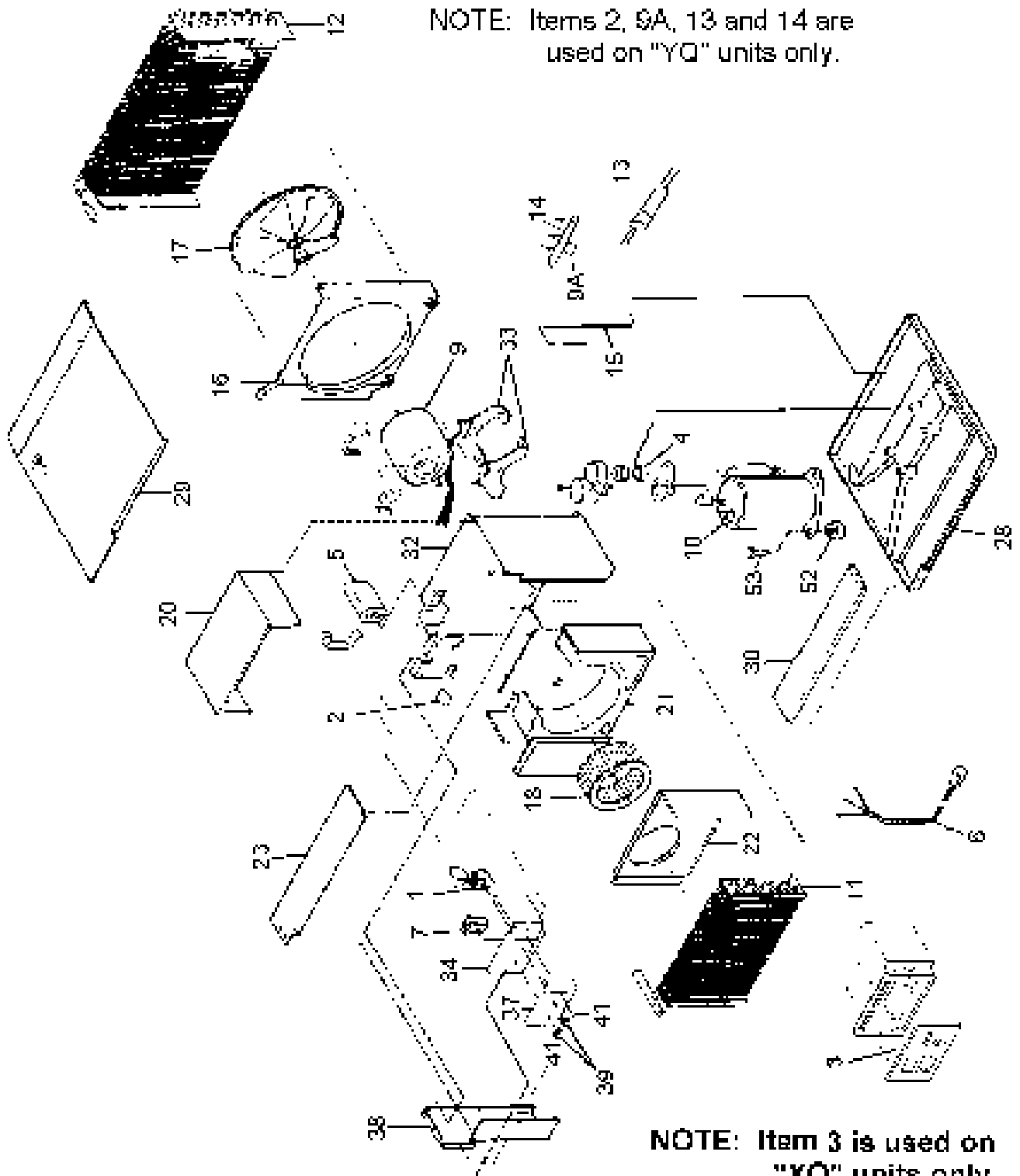

NOTE: Item 3 is used on "XQ" units only.

"Q" SERIES CABINET PARTS

NOTE: Items 51, 56 and 57 are not included with the "YQ" unit.

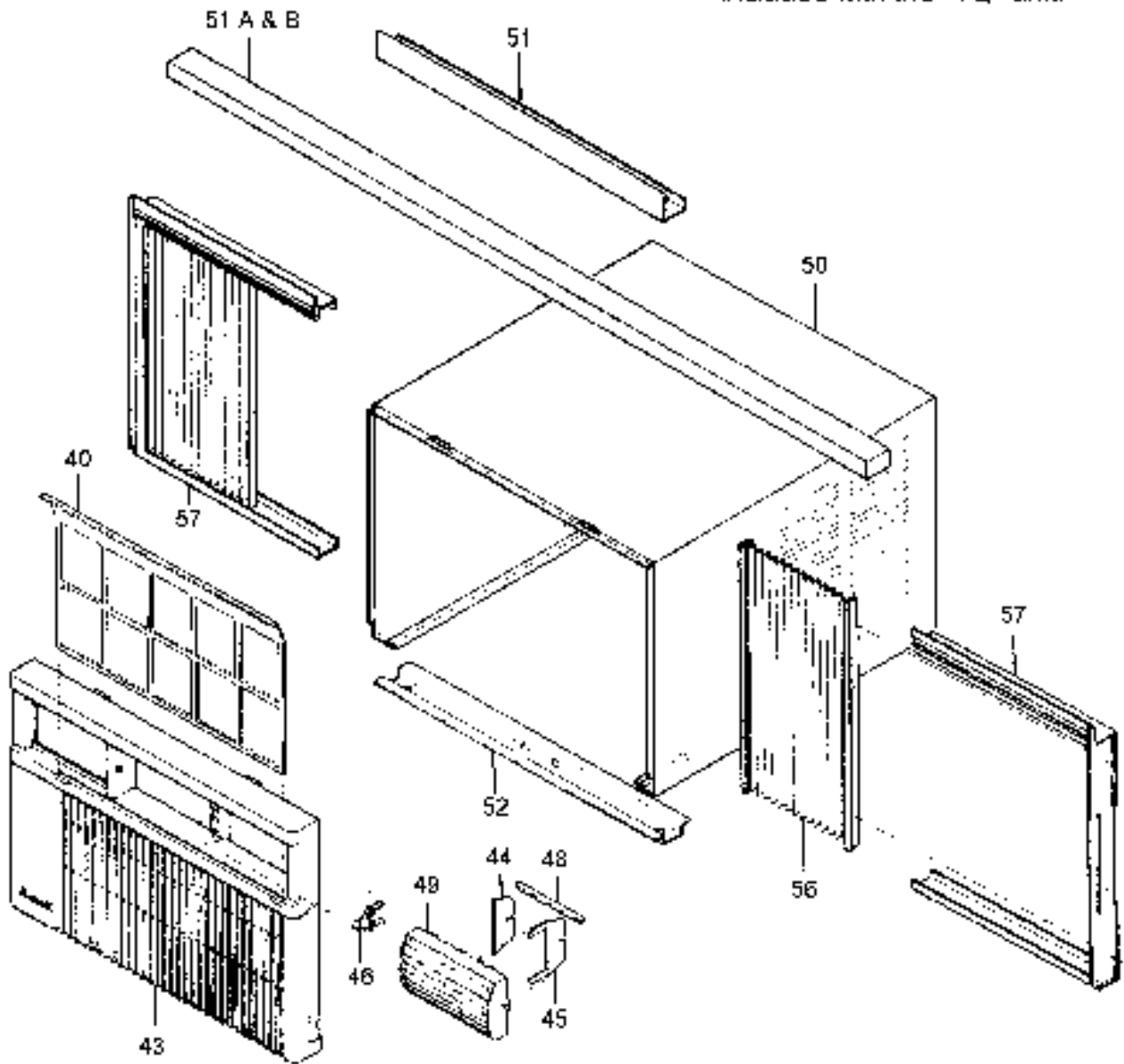

PORTABLE "Q" SERIES

REF	DESCRIPTION	PART #	ELECTRICAL PARTS													CODE	
			KQ05E10B-B	KQ06J10B-A	KQ06J10B-B	KQ08J10C-A	SQ05J10B-B	SQ06J10B-A	SQ06J10B-B	SQ08J10D-A	XQ05J10-B	XQ06J10-A	XQ06J10-B	XQ08J10A-A	EQ08J11-A		EQ08J11B-A
1	THERMOSTAT	61828501	1	1	1	1	1	1	1								120
1	THERMOSTAT	61822401												1	1	1	120
1	THERMOSTAT	67300400															120
1	THERMOSTAT	67300402															120
2	THERMOSTAT, DEFROST	60442500														1	122
3	ELECTRONIC BOARD	61921102								1	1	1	1				331
*	REMOTE CONTROL	61826603								1	1	1	1				350
*	RESISTOR	61900600				1	1	1	1	1							200
2	OVERLOAD	60364594													1		190
4	OVERLOAD	61764539	1			1	1			1							190
	OVERLOAD	61764526			1							1					
2	OVERLOAD	61764527		1				1				1					190
4	OVERLOAD	61764516															190
4	OVERLOAD	61764510												1			190
4	OVERLOAD	61764507							1				1			1	190
4	OVERLOAD	67301406															190
4	OVERLOAD	67301404															190
5	CAPACITOR	61080539													1		150
5	CAPACITOR	61080550	1	1	1	1	1	1	1	1	1	1	1	1		1	150
5	CAPACITOR	61080350															150
5	CAPACITOR	67300702															150
5	CAPACITOR	67300704															150
6	SUPPLY CORD	60500065	1	1	1	1	1	1	1	1	1	1	1	1	1	1	220
6	SUPPLY CORD	67300000															220
6	SUPPLY CORD	67300001															220
7	SWITCH	60441610												1	1		130
7	SWITCH	60441606	1	1	1												130
7	SWITCH	60441607														1	130
7	SWITCH	60607206				1	1	1	1	1							130
7	SWITCH	67300500															130
7	SWITCH	67300501															130
*	SWITCH (YES - NO)	61806102				1	1	1	1	1							132
8	SWITCH (YES - NO)	67305701															132
9	FAN MOTOR	61871448				1	1	1	1	1	1	1	1				110
9	FAN MOTOR	61871449	1	1	1											1	110
9	FAN MOTOR	61871423															110
9	FAN MOTOR	61871424												1	1		110
9	FAN MOTOR	67303006															110
9	FAN MOTOR	67303004															110
9	FAN MOTOR	67303005															110
9	FAN MOTOR	67400157															110
9A	SOLENOID, REV. VALVE	25018800														1	240
*	1KW HEATER	61929600												1	1		
	OVERLOAD HTR ELEMENT	61827902												1	1		

* PARTS NOT SHOWN

PORTABLE "Q" SERIES

REF	DESCRIPTION	PART #	REFRIGERATION SYSTEM PARTS													CODE		
			KQ05E10B-B	KQ06J10B-A	KQ06J10B-B	KQ08J10C-A	SQ05J10B-B	SQ06J10B-A	SQ06J10B-B	SQ08J10D-A	XQ05J10-B	XQ06J10-A	XQ06J10-B	XQ08J10A-A	EQ08J11-A		EQ08J11B-A	YQ06J10B-A
10	COMPRESSOR	61985100	1			1	1				1							600
10	COMPRESSOR	61716624		1				1				1						600
10	COMPRESSOR	61716627																600
10	COMPRESSOR	61716643			1					1			1					600
10	COMPRESSOR	61562832								1				1				600
10	COMPRESSOR	61562807														1		600
10	COMPRESSOR	61562833												1				600
10	COMPRESSOR	61562833																600
10	COMPRESSOR	61562829															1	600
10	COMPRESSOR	67301606																600
10	COMPRESSOR	67301605																600
10	COMPRESSOR	67301604																600
10	COMPRESSOR	67301602																600
10	COMPRESSOR	67400162																600
11	EVAPORATOR COIL	61600266	1															400
11	EVAPORATOR COIL	61600267		1	1													400
11	EVAPORATOR COIL	61600258								1			1	1	1			400
11	EVAPORATOR COIL	61600403				1	1				1							400
11	EVAPORATOR COIL	61600257						1	1			1	1				1	400
11	EVAPORATOR COIL	67302406																400
11	EVAPORATOR COIL	67302402																400
11	EVAPORATOR COIL	67302403																400
11	EVAPORATOR COIL	67302405																400
11	EVAPORATOR COIL	67400160																400
12	CONDENSER COIL	61600352	1															410
12	CONDENSER COIL	61600349		1	1													410
12	CONDENSER COIL	61600519						1	1	1		1	1	1	1	1		410
12	CONDENSER COIL	61600517				1	1				1							410
12	CONDENSER COIL	61600350																410
12	CONDENSER COIL	61600515															1	410
12	CONDENSER COIL	67303306																410
12	CONDENSER COIL	67303302																410
12	CONDENSER COIL	67303303																410
12	CONDENSER COIL	67303305																410
*	DRIER, LIQUID	61481300	1	1	1	1	1	1	1	1	1	1	1	1	1	1	1	480
*	DRIER, SUCTION	61828200	1	1	1	1	1	1	1	1	1	1	1	1	1	1	1	480
13	CHECKVALVE	61824400															1	510
14	REVERSING VALVE	25018200															1	500
15	CAPILLARYTUBE	03760513							1	1			1	1	1			471
15	CAPILLARYTUBE	03760543							1			1	1					471
15	CAPILLARYTUBE	03760545	1	1														471
15	CAPILLARYTUBE	03760545			1													471
15	CAPILLARYTUBE	03760543				1	1				1							471
15	CAPILLARYTUBE (HTG)	03760500															1	471
15	CAPILLARYTUBE (CLG)	03760554															1	471

* PARTS NOT SHOWN

PORTABLE "Q" SERIES

REF	DESCRIPTION	PART NO#	CHASSIS PARTS														CODE
			KQ05E10B-B	KQ06J10B-A	KQ06J10B-B	KQ08J10C-A	SQ05J10B-B	SQ06J10B-A	SQ06J10B-B	SQ08J10D-A	XQ05J10-B	XQ06J10-A	XQ06J10-B	XQ08J10A-A	EQ08J11-A	EQ08J11B-A	
16	SHROUD, CONDENSER	61627601	1	1	1	1	1	1	1	1	1	1	1	1	1	1	720
16	SHROUD, CONDENSER	67303105															720
16	SHROUD, CONDENSER	67303100															720
16	SHROUD, CONDENSER	67303102															720
16	SHROUD, CONDENSER	67303104															720
16	SHROUD, CONDENSER	67400154															
17	FAN BLADE	61634001	1	1	1	1	1	1	1	1	1	1	1	1	1	1	710
17	FAN BLADE	67303204															710
17	FAN BLADE	67303200															710
17	FAN BLADE	67303201															710
17	FAN BLADE	67303203															710
18	BLOWER WHEEL	60610606	1	1	1	1	1	1	1	1	1	1		1	1	1	700
	BLOWER WHEEL	60610612											1				
18	BLOWER WHEEL	67302605															700
18	BLOWER WHEEL	67302600															700
18	BLOWER WHEEL	67302603															700
18	BLOWER WHEEL	67302604															700
19	SPRING CLAMP	67302500															999
20	COVER, BLOWER WRAP	61633101	1	1	1	1	1	1	1	1	1	1	1	1	1	1	745
21	WRAPPER, BLOWER	61931600												1	1		741
21	WRAPPER, BLOWER	61633300	1	1	1	1	1	1	1	1	1	1	1			1	741
22	FRONT, BLOWER	61928800												1	1		742
22	FRONT, BLOWER	61633201	1	1	1	1	1	1	1	1	1	1				1	742
23	DECK, BLOWER	61619405												1	1		745
23	DECK, BLOWER	61619404	1	1	1	1	1	1	1	1	1	1				1	745
24	SCROLL, BLOWER	67302800															743
24	SCROLL, BLOWER	67302802															743
25	ORIFICE, BLOWER	67303401															738
26	ORIFICE RING, BLOWER	67303403															738
26	ORIFICE RING, BLOWER	67303404															738
26	ORIFICE RING, BLOWER	67303405															738

* PARTS NOT SHOWN

PORTABLE "Q" SERIES

REF	DESCRIPTION	PART NO#	CHASSIS PARTS													CODE		
			KQ05E10B-B	KQ06J10B-A	KQ06J10B-B	KQ08J10C-A	SQ05J10B-B	SQ06J10B-A	SQ06J10B-B	SQ08J10D-A	XQ05J10-B	XQ06J10-A	XQ06J10-B	XQ08J10A-A	EQ08J11-A		EQ08J11B-A	YQ06J10B-A
27	AIR GUIDE UPPER	67302706																745
27	AIR GUIDE LOWER	67302707																742
27	AIR GUIDE ASSLY	67302700																742
27	AIR GUIDE ASSLY	67302703																742
27	AIR GUIDE ASSLY	67302705																742
27	AIR GUIDE ASSLY	67400159																742
28	BASE PAN	61626302	1	1	1	1	1	1	1	1	1	1	1			1		730
28	BASE PAN	61626303								1								730
28	BASE PAN	61626304												1				730
28	BASE PAN	61626305													1			730
28	BASE PAN	67302906																730
28	BASE PAN	67302902																730
28	BASE PAN	67302903																730
28	BASE PAN	67302905																730
28	BELLOWS CONDENSATE	60179900	1						1	1	1	1	1	1	1	1	1	801
29	COVER, UNIT TOP	61715600															1	746
29	COVER, UNIT TOP	61715601	1	1	1	1	1	1	1	1	1	1	1	1	1	1	1	746
30	DRAIN PAN, EVAP.	61638400	1	1	1	1	1	1	1	1	1	1	1	1	1	1	1	840
31	BRACE, TOP	67303901																722
32	INNER WALL	61597312	1	1	1													777
32	INNER WALL	61597308				1	1	1	1	1	1	1						777
32	INNER WALL	61937800												1	1			777
32	INNER WALL	61597315							1				1				1	777
32	INNER WALL	67306800																777
33	FAN MOTOR MOUNT	61776901	1														1	900
33	FAN MOTOR MOUNT	61776903		1	1	1	1	1	1	1	1	1	1	1	1	1		900
*	SCREW, FAN MTR. MT.	21004672	4	4	4	4	4	4	4	4	4	4	4	4	4	4	4	999
33	FAN MOTOR MOUNT	67303604																900
33	FAN MOTOR MOUNT	67303602																900
33	FAN MOTOR MOUNT	67400158																900
34	CONTROL MT. BRACKET	61619612	1	1	1	1	1	1	1					1	1	1		763
34	CONTROL MT. BRACKET	61923900								1	1	1	1					763
35	CONTROL BOX ASSLY	67305304																763
35	CONTROL BOX ASSLY	67305301																763
35	CONTROL BOX ASSLY	67305303																763
35	CONTROL BOX ASSLY	67400156																763
36	COVER, RIS CTR. BOX	67300304																747

* PARTS NOT SHOWN

PORTABLE "Q" SERIES

REF	DESCRIPTION	PART #	CHASSIS PARTS													CODE		
			KQ05E10B-B	KQ06J10B-A	KQ06J10B-B	KQ08J10C-A	SQ05J10B-B	SQ06J10B-A	SQ06J10B-B	SQ08J10D-A	XQ05J10-B	XQ06J10-A	XQ06J10-B	XQ08J10A-A	EQ08J11-A		EQ08J11B-A	YQ06J10B-A
37	CONTROL DEC. PANEL	61715914	1	1	1													760
37	CONTROL DEC. PANEL	61715915				1	1	1	1	1								760
37	CONTROL DEC. PANEL	61715916												1	1	1	760	
37	CONTROL DEC. PANEL	67305501															760	
37	CONTROL DEC. PANEL	67400149															760	
38	PANEL ASSLY, LIS	61924900	1	1	1	1	1	1	1	1	1	1	1	1	1	1	765	
39	CONTROL KNOBS	61911600	2	2	2	2	2	2	2	2				2	2	2	761	
39	CONTROL KNOBS	67304100															761	
39	CONTROL KNOBS	67304103															761	
39	CONTROL KNOBS	67400153															761	
*	HOLDER, TSTAT BULB	61900500	1	1	1	1	1	1	1	1				1	1	1	764	
*	HOLDER, THERMISTER	61925001									1	1	1	1			764	
40	FILTER, AIR	61632302	1	1	1	1	1	1	1	1	1	1	1	1	1	1	754	
40	FILTER, AIR	67304300															754	
40	FILTER, AIR	67304302															754	
41	EXHAUST SLIDE BUTTON	61923800									1	1	1	1			761	
*	HOLE LINER, EXHAUST	61924400									1	1	1	1			999	
*	SLIDER SNAP, EXHAUST	61923801									1	1	1	1			999	
*	LINK, EXHAUST	61639300				1	1	1	1	1							811	
*	LINK, EXHAUST	61927600									1	1	1	1			811	
*	EXHAUST DOOR	61632200				1	1	1	1	1	1	1	1	1			810	
*	WIRE CLIP, EXHAUST	60301800				1	1	1	1	1	1	1	1	1			999	
*	EXHAUST DOOR	61632200				1	1	1	1	1	1	1	1	1			810	
*	WIRE CLIP, EXHAUST	60301800				1	1	1	1	1	1	1	1	1			999	
*	CHANNEL, EXHAUST	61656200				1	1	1	1	1	1	1	1	1			999	
*	SLIDE, EXHAUST	61638000				1	1	1	1	1	1	1	1	1			761	
*	LINK, EXHAUST	61639300				1	1	1	1	1	1	1	1	1			811	
41	BUTTON, EXHAUST	61911700				1	1	1	1	1	1	1	1	1			814	
42	DAMPER, EXHAUST	67303502															810	

*PARTS NOT SHOWN

PORTABLE "Q" SERIES

REF	DESCRIPTION	PART #	CHASSIS PARTS													CODE	
			KQ05E10B-B	KQ06J10B-A	KQ06J10B-B	KQ08J10C-A	SQ05J10B-B	SQ06J10B-A	SQ06J10B-B	SQ08J10D-A	XQ05J10-B	XQ06J10-A	XQ06J10-B	XQ08J10A-A	EQ08J11-A		EQ08J11B-A
43	FRONT, DECORATIVE	61637706	1	1	1												750
43	FRONT, DECORATIVE	61637708				1	1	1	1	1	1	1	1	1	1	1	750
43	FRONT, DECORATIVE	67306003															750
43	FRONT, DECORATIVE	67306002															750
44	LOUVER, VERTICAL	61626704	8	8	8	8	8	8	8	8	8	8	8	8	8	8	882
44	LOUVER, VERTICAL	67304500															882
44	LOUVER, VERTICAL	67306250															882
44	LOUVER, VERTICAL	67400151															882
45	LOUVER, VERTICAL CTR	61626705	2	2	2	2	2	2	2	2	2	2	2	2	2	2	882
46	PIVOT PIECE	61493801	2	2	2	2	2	2	2	2	2	2	2	2	2	2	999
45	LOUVER, VERTICAL CTR.	67304501															882
47	LOUVER, HORIZONTAL	67306250															881
47	LOUVER, HORIZONTAL	67400150															881
48	CONNECTOR RAIL	67304600															999
48	CONNECTOR RAIL	61626801	2	2	2	2	2	2	2	2	2	2	2	2	2	2	999
49	GRILLE, DISCHARGE	61626602	2	2	2	2	2	2	2	2	2	2	2			2	881
50	SHELL, OUTER	61623000	1	1	1	1	1	1	1	1	1	1	1	1	1	1	720
51	ANGLE, TOP SUPPORT	61627303	1	1	1	1	1	1	1	1	1	1	1	1	1	1	999
52	CHANNEL, SILL	61627201	1	1	1	1	1	1	1	1	1	1	1	1	1	1	999
50	SHELL, OUTER	67303704															770
50	SHELL, OUTER	67303703															770
51	ANGLE, TOP SUPPORT	67304000															999
*	SCRIPT, FRIEDRICH	60169103		1	1	1	1	1	1	1	1	1	1	1	1	1	999
*	SCRIPT, FRIEDRICH	60169105	1														999
51A	GASKET, CHASSIS SEAL	61717300	1	1	1	1	1	1	1	1	1	1	1	1	1	1	780
51B	GASKET, WINDOW SEAL	60073300	1	1	1	1	1	1	1	1	1	1	1	1	1	1	780
*	BAG ASSLY (SCREWS)	61778700	1	1	1	1	1	1	1	1	1	1	1				999
*	BAG ASSLY (SCREWS)	61778701												1	1	1	999

*PARTS NOT SHOWN

PORTABLE "Q" SERIES

REF	DESCRIPTION	PART #														CODE				
			KQ05E10B-B	KQ06J10B-A	KQ06J10B-B	KQ08J10C-A	SQ05J10B-B	SQ06J10B-A	SQ06J10B-B	SQ08J10D-A	XQ05J10-B	XQ06J10-A	XQ06J10-B	XQ08J10A-A	EQ08J11-A		EQ08J11B-A	YQ06J10B-A		
*	COUNTER WEIGHT	61715800	2	2	2	2	2	2	2	2	2	2	2	2	2	2	2	2	999	
*	SEAL, FAN MOTOR	60217902	1	1	1	1	1	1	1	1	1	1	1	1	1	1	1	1	780	
52	GROMMET, COMP. MT.	61028900	3	3	3	3	3	3	3	3	3	3	3	3	3	3	3	3	790	
52	GROMMET, COMP. MT.	67301901																	790	
52	GROMMET, COMP. MT.	67301900																	790	
53	SCREW, COMP. MT.	91400400	3	3	3	3	3	3	3	3	3	3	3	3	3	3	3	3	999	
54	NUT, COMP. MT.	67301700																	999	
55	WASHER, COMP. MT.	67301800																	999	
56	CURTAIN ASSLY.	61680203	2	2	2	2	2	2	2	2	2	2	2	2	2	2	2	2	999	
56	CURTAIN,FRAME L\S ASSY	67303800																	999	
56	CURTAIN,FRAME R\S ASSY	67303801																	999	
56	CURTAIN,FRAME L\S ASSY	67303802																	999	
56	CURTAIN,FRAME R\S ASSY	67303803																	999	
58	UPPER GUIDE	67304000																	999	
59	LOWER BRACKET	67303901																	999	
58	UPPER GUIDE	67304002																	999	
59	BRACKET, ANGLE	67306500																	999	
60	NUT	67306700																	999	
61	BOLT	67306600																	999	
62	FRAME GUIDE	67306400																	999	
63	DRAIN PIPE	67307000																	800	
64	WASHER	67306902																	999	
65	RUBBER GASKET	67307100																	999	
	CARTON, SHIPPING	61630613		1													1	1	1	999
*	CARTON, SHIPPING	61902000	1	1	1	1	1	1	1	1	1	1	1	1	1	1	1	1	999	
*	PAD, SHIPPING TOP	61716400	1	1	1	1	1	1	1	1	1	1	1	1	1	1	1	1	999	
*	PAD, SHIPPING BOTTOM	61710001	1	1	1	1	1	1	1	1	1	1	1	1	1	1	1	1	999	

OPTIONAL ACCESSORY ITEMS

REF	DESCRIPTION	PART #														CODE				
			KQ05E10B-B	KQ06J10B-A	KQ06J10B-B	KQ08J10C-A	SQ05J10B-B	SQ06J10B-A	SQ06J10B-B	SQ08J10D-A	XQ05J10-B	XQ06J10-A	XQ06J10-B	XQ08J10A-A	EQ08J11-A		EQ08J11B-A	YQ06J10B-A		
*	ANTI-ICE KIT	61680600	1	1	1	1	1	1	1	1										250
*	START ASSIST (PTCR)	61008903	1	1	1	1	1	1	1	1	1	1	1	1	1	1	1	1	1	160
*	START ASSIST (PTCR)	61883800															1	1	1	160
*	DRAIN KIT, DC-2	01900235	1	1	1						1		1	1	1	1	1	1	1	999

* PARTS NOT SHOWN

"S" Series
115V / 230V
Small Chassis
Room Air Conditioner Section

SMALL CHASSIS "S" SERIES CHASSIS PARTS (ES, KS, RS, SS & YS)

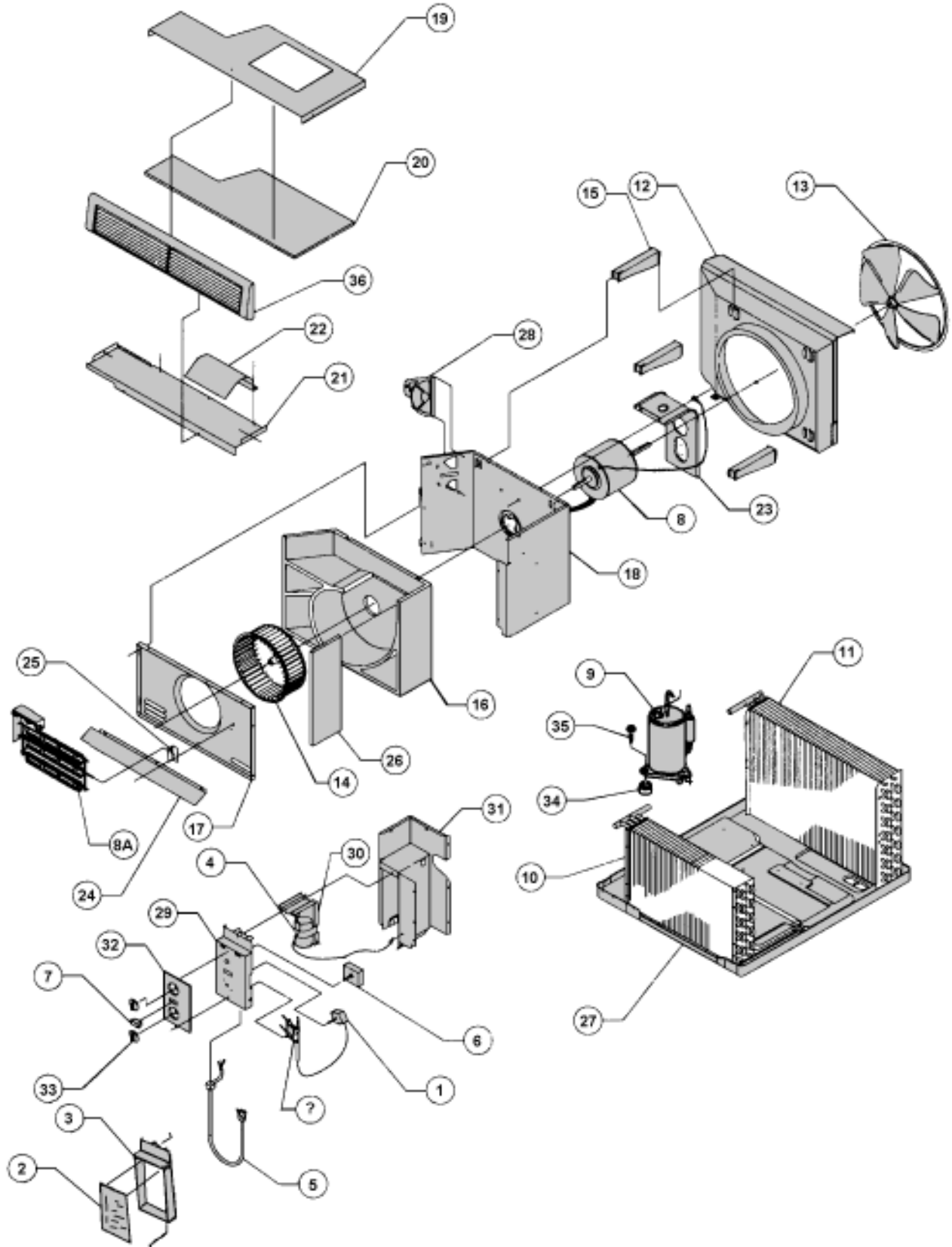

SMALL CHASSIS "S" SERIES CHASSIS PARTS (ES, KS, RS, SS & YS)

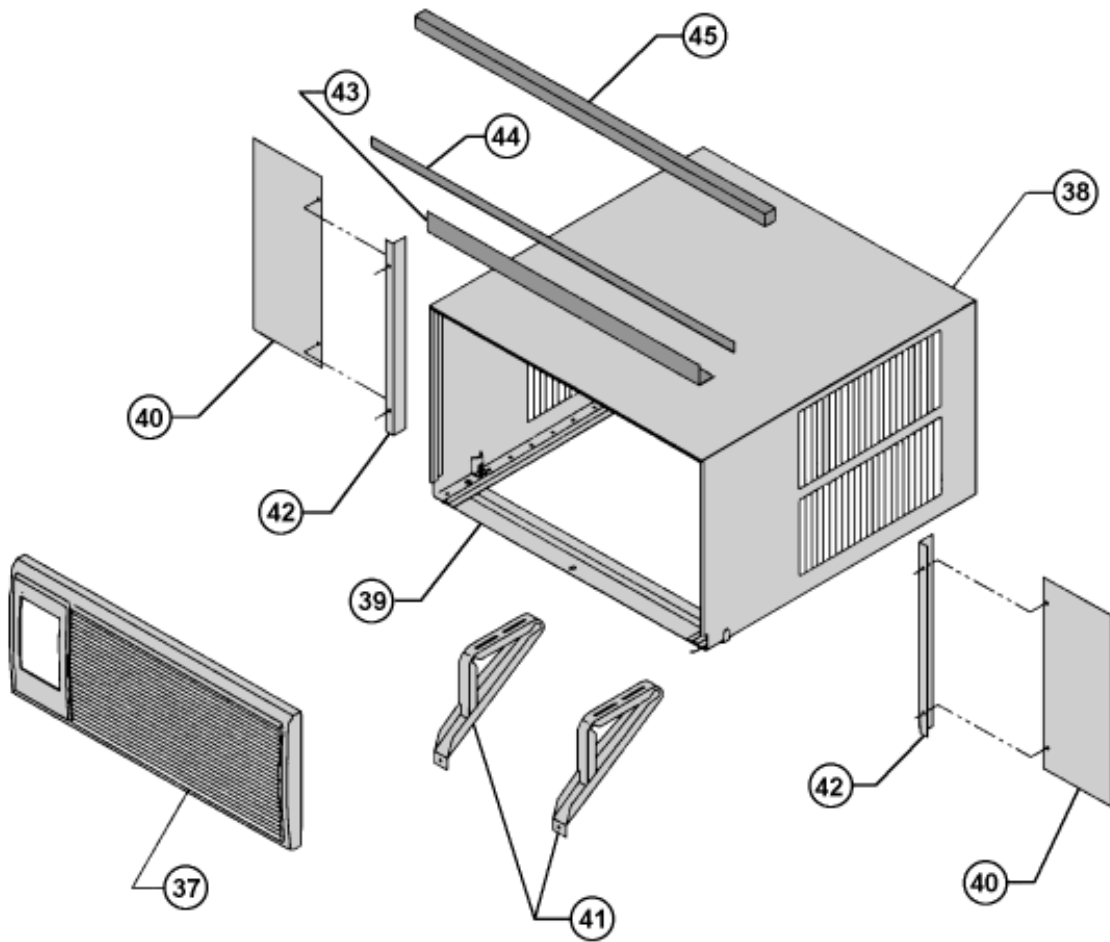

SMALL CHASSIS "S" SERIES PARTS LIST - 115V

REF	DESCRIPTION	PART NO#	KS 115						RS 115				SS 115						CODE	
			KS10E10-A	KS12E10-A	KS10J10-B	KS12J10A-A	KS12J10B-A	KS15J10-A	RS12J10A-B	RS10J10C	RS10J10-B	RS15J10-A	SS08J10R-A	SS08J10R-B	SS09J10B-A	SS09J10C-A	SS10J10AR-A	SS12J10AR-B		SS14J10R-A
1	THERMOSTAT	61822500	1	1	1	1	1	1	1	1	1									120
1	THERMOSTAT	61822400																	1	120
*	THERMOSTAT, DEFROST	61350313																	1	122
2	ELECTRONIC CTRL.	61921103										1	1	1	1	1	1	1		331
*	REMOTE CONTROL	61826602										1	1	1	1	1	1	1		350
3	RESISTOR	61808000	1	1	1	1	1	1	1	1	1								1	200
*	OVERLOAD	60364598																		190
*	OVERLOAD	61764519	1	1	1		1		1	1						1	1			190
*	OVERLOAD	61764504				1														190
	OVERLOAD	61764544					1				1							1		190
*	OVERLOAD	60364594																		190
*	OVERLOAD	61764536												1					1	190
*	OVERLOAD	61764507										1								190
*	OVERLOAD	61764509											1							190
*	OVERLOAD	61764510												1						190
4	CAPACITOR	61080535			1	1						1		1						150
4	CAPACITOR	61080538																		150
4	CAPACITOR	61080554	1						1	1			1		1	1			1	150
4	CAPACITOR	61080569		1			1	1	1			1					1	1		150
4	CAPACITOR	61080335																		150
6	SUPPLY CORD	60500054	1		1				1	1	1		1	1	1	1	1	1	1	220
6	SUPPLY CORD	60500053		1		1	1	1				1							1	220
6	SWITCH	60607203	1	1	1	1	1	1												130
6	SWITCH	60607205							1	1	1	1								130
6	SWITCH	60607204																	1	130
7	SWITCH (YES - NO)	61806102	1	1	1	1	1	1	1	1	1								1	132
8	FAN MOTOR	61871431	1		1			1												110
8	FAN MOTOR	61871428							1	1		1		1	1	1				110
8	FAN MOTOR	61871430						1									1			110
8	FAN MOTOR	61871436		1		1	1												1	110
8	FAN MOTOR	61071480																		110
8	FAN MOTOR	61871444								1		1						1		110
8	FAN MOTOR	61071476																		110
8	FAN MOTOR	61071479																		110
*	SOLENOID COIL	25063500																	1	240

* PARTS NOT SHOWN

SMALL CHASSIS "S" SERIES PARTS LIST - 115V

REF	DESCRIPTION	PART NO#	KS 115						RS 115				SS 115						CODE	
			KS10E10-A	KS12E10-A	KS10J10-B	KS12J10A-A	KS12J10B-A	KS15J10-A	RS12J10A-B	RS10J10C	RS10J10-B	RS15J10-A	SS08J10R-A	SS08J10R-B	SS09J10B-A	SS09J10C-A	SS10J10AR-A	SS12J10AR-B		SS14J10R-A
9	COMPRESSOR	61716622			1															600
9	COMPRESSOR	61716641	1																	600
9	COMPRESSOR	61562838				1														600
9	COMPRESSOR	61562832										1								600
9	COMPRESSOR	61562833											1							600
9	COMPRESSOR	61716622																		600
9	COMPRESSOR	61716640		1			1		1									1		600
9	COMPRESSOR	61716653						1				1							1	600
9	COMPRESSOR	61562608												1					1	600
9	COMPRESSOR	61716641								1	1						1			600
9	COMPRESSOR	61716646													1					600
9	COMPRESSOR	61562838																		600
9	COMPRESSOR	61562802																		600
9	COMPRESSOR	61562832																		600
9	COMPRESSOR	61562833																		600
9	COMPRESSOR	61562807																		600
10	EVAPORATOR COIL	62050005						1				1							1	400
10	EVAPORATOR COIL	61850101			1								1	1		1				400
10	EVAPORATOR COIL	61850100	1	1		1	1		1	1	1			1		1	1		1	400
11	CONDENSER COIL	61850303			1								1	1		1				410
11	CONDENSER COIL	61850217		1		1	1		1								1			410
11	CONDENSER COIL	61850302	1					1		1	1	1			1		1	1	1	410
11	CONDENSER COIL	61850300																		410
*	DRIER, LIQUID	60308101	1	1	1	1	1	1	1	1	1	1	1	1	1	1	1	1		480
*	DRIER, SUCTION	61828200	1	1	1	1	1	1	1	1	1	1	1	1	1	1	1	1	1	480
*	CHECK VALVE/CAP ASSY	61939500																		510
*	REVERSING VALVE	61939600																		500
*	CAPILLARY TUBE	O1360511																		471
*	CAPILLARY TUBE	03760520																		471
*	CAPILLARY TUBE	03760473																		471
*	CAPILLARY TUBE	O1389903																		471
	CAPILLARY TUBE ASSY	61941400													1					471
*	CAPILLARY TUBE ASSY	61918300				1														471
*	CAPILLARY TUBE ASSY	61916800			1															471
	CAPILLARY TUBE ASSY	61918600												1						
*	CAPILLARY TUBE ASSY	61918601	1							1	1						1			1
*	CAPILLARY TUBE ASSY	61918701							1										1	
	CAPILLARY TUBE ASSY	61939100													1					
*	CAPILLARY TUBE ASSY	61918301		1			1													
*	CAPILLARY TUBE ASSY	61943700						1			1	1							1	

* PARTS NOT SHOWN

SMALL CHASSIS "S" SERIES PARTS LIST - 115V

REF	DESCRIPTION	PART NO#	KS						RS				SS						CODE	
			KS10E10-A	KS12E10-A	KS10J10-B	KS12J10A-A	KS12J10B-A	KS15J10-A	RS12J10A-B	RS10J10-C	RS10J10-B	RS15J10-A	SS08J10R-A	SS08J10R-B	SS09J10B-A	SS09J10C-A	SS10J10AR-A	SS12J10AR-B		SS14J10R-A
12	SHROUD, CONDENSER	61803600	1	1	1	1	1	1	1	1	1	1	1	1	1	1	1	1	1	720
*	SHROUD, SML WSUMP LOOP	61803601	1	1	1	1	1	1	1	1	1	1	1	1	1	1	1	1	1	720
13	FAN BLADE, CONDENSER	60542003	1	1	1	1	1	1	1	1	1	1	1	1	1	1	1	1	1	710
14	BLOWER WHEEL, EVAP.	60610603		1	1		1	1	1			1	1	1	1	1		1		700
14	BLOWER WHEEL, EVAP.	60610604	1							1	1							1		700
14	BLOWER WHEEL, EVAP.	60610601				1														700
14	BLOWER WHEEL, EVAP.	60610607																		700
15	BRACE, COND. SHROUD	61802600	3	3	3	3	3	3	3	3	3	3	3	3	3	3	3	3	3	722
16	SCROLL	61814900																		743
16	SCROLL	61814902	1	1	1	1	1	1	1	1	1	1	1	1	1	1	1	1	1	743
17	BLOWER FRONT	61817300	1	1	1	1	1	1	1	1	1	1	1	1	1	1	1	1	1	742
*	INSULATION, INNER WALL	61816900	1	1	1	1	1	1	1	1	1	1	1	1	1	1	1	3	1	781
18	INNER WALL	61907300	1	1	1	1	1	1	1	1	1	1	1	1	1	1	1	1	1	777
19	COVER, TOP	61906700	1	1	1	1	1	1	1	1	1	1	1	1	1	1	1	1	1	746
20	INSULATION, TOP COVER	61816701	1	1	1	1	1	1	1	1	1	1	1	1	1	1	1	1	1	781
21	DECK	61817100	1	1	1	1	1	1	1	1	1	1	1	1	1	1	1	1	1	745
22	AIR FOIL	61820200	1	1	1	1	1	1	1	1	1	1	1	1	1	1	1	1	1	744
23	MOUNT, FAN MOTOR	61802500	1	1	1	1	1	1	1	1	1	1	1	1	1	1	1	1	1	900
24	SHIELD, BOTTOM	61812900																	1	999
25	BRACKET, HEATER MT.	61818900																		999
26	SHIELD, SIDE	61821800																	1	999
27	BASE PAN	61803409				1							1	1	1	1				730
27	BASE PAN	61803411	1	1	1		1	1	1	1	1						1	1	1	730
27	BASE PAN	61809001																	1	730
*	DRAIN PAN	61803800	1	1	1	1	1	1	1	1	1	1	1	1	1	1	1	1	1	840
*	BELLOWS, DRAIN VALVE	60179900																	1	801
*	GRILLE, REAR	61818800	1	1	1	1	1	1	1	1	1	1	1	1	1	1	1	1	1	771
28	DOOR, SLIDE ASSLY.	61821500	1	1	1	1	1	1	1	1	1	1	1	1	1	1	1	1	1	810
*	CONNECTOR, SLIDE DOOR	61814800	1	1	1	1	1	1	1	1	1	1	1	1	1	1	1	1	1	811
29	PANEL, CTRL. MT.	61807200	1	1	1	1	1	1	1	1	1								1	999
29	PANEL, CTRL. MT.	61807201											1	1	1	1	1	1	1	999
30	BRACKET, CAP. MT	61820400	1	1	1	1	1	1	1	1	1	1	1	1	1	1	1	1	1	999
*	PANEL, L/S	61937200	1	1	1	1	1	1	1	1	1	1	1	1	1	1	1	1	1	999
*	PANEL, LIS	61907000												1						999
31	PARTITION, CTRL. BOX	61802800	1	1	1	1	1	1	1	1	1	1	1	1	1	1	1	1	1	999
32	DECORATIVE PANEL	61822603							1	1	1	1								999
*	BUSHING, SUPPLY CORD	60071312	1	1	1	1	1	1	1	1	1		1	1	1	1	1	1	1	999
32	DECORATIVE PANEL	61822600	1	1	1	1	1	1												999
33	KNOBS, CTRL.	61493905	2	2	2	2	2	2	2	2	2								2	761
*	HOLDER, THERMISTER	61925001											1	1	1	1	1	1	1	764
*	HOLDER, AIR FILTER	61823000	2	2	2	2	2	2	2	2	2	2	2	2	2	2	2	2	2	756
*	FILTER, AIR	60865808	1	1	1	1	1	1	1	1	1	1	1	1	1	1	1	1	1	754
*	CLAMP, SUPPLY CORD	91500301	1	1	1	1	1	1	1	1	1	1	1	1	1	1	1	1	1	999
*	BRACKET, RESISTO BLOCK	61820600	1	1	1	1	1	1	1	1	1								1	999
34	GROMMET, SUCTION LINE	61807602	1	1	1	1	1	1	1	1	1	1	1	1	1	1	1	1	1	999
34	GROMMET, COMPRESSOR	61028900	3	3	3	3	3	3	3	3	3	3	3	3	3	3	3	3	3	790
35	SCREW, COMPRESSOR MT.	91400400	3	3	3	3	3	3	3	3	3	3	3	3	3	3	3	3	3	999
*	COUNTER WEIGHT	61715800	2	2	2	2	2	2	2	2	2	2	2	2	2	2	2	2	2	999
36	PLENUM ASSLY.	61810200	1	1	1	1	1	1	1	1	1	1	1	1	1	1	1	1	1	753

* PARTS NOT SHOWN

SMALL CHASSIS "S" SERIES PARTS LIST - 115V

REF	DESCRIPTION	PART NO#	KS						RS			SS						CODE			
			KS10E10-A	KS12E10-A	KS10J10-B	KS12J10A-A	KS12J10B-A	KS15J10A	RS12J10A-1	RS10J10-C	RS10J10-B	RS15J10A	SS08J10R-A	SS08J10R-B	SS09J10B-A	SS09J10C-A	SS10J10AR-A		SS12J10AR-B	SS14J10R-A	YS09J10B-A
*	LEVER, FRESH & EXHAUST	61809200	1	1	1	1	1	1	1	1	1	1	1	1	1	1	1	1	1	1	
*	KNOB, FRESH & EXHAUST	61809300	1	1	1	1	1	1	1	1	1	1	1	1	1	1	1	1	1	1	1
37	INTAKE GRILLE	61808900	1	1	1	1	1	1	1	1	1	1	1	1	1	1	1	1	1	1	
*	LATCH, INTAKE GRILLE	61819900	2	2	2	2	2	2	2	2	2	2	2	2	2	2	2	2	2	2	
38	OUTER SHELL ASSLY	61803205	1	1	1	1	1	1	1	1	1	1	1	1	1	1	1	1	1	1	
39	SILL PLATE	61808403	1	1	1	1	1	1	1	1	1	1	1	1	1	1	1	1	1	1	
*	CHASSIS GUIDE, SHELL	61819601	2	2	2	2	2	2	2	2	2	2	2	2	2	2	2	2	2	2	
*	FRIEDRICH SCRIPT	60169105			1	1	1	1	1	1	1	1	1	1	1	1	1	1	1	1	1
*	PUSHNUTS, SCRIPT	91002900	2	2	2	2	2	2	2	2	2	2	2	2	2	2	2	2	2	2	
*	ACCESSORY PKGE.	61105004			1	1	1	1	1	1	1	1	1	1	1	1	1	1	1	1	
40	WINGBOARD	60294408	1	1	1	1	1	1	1	1	1	1	1	1	1	1	1	1	1	1	
41	BRACKET, SUPPORT	61109503	1	1	2	2	2	2	2	2	2	2	2	2	2	2	2	2	2	2	
42	ANGLE, WINGBOARD	61819801	2	2	2	2	2	2	2	2	2	2	2	2	2	2	2	2	2	2	
43	ANGLE, TOP	61819701	1	1	1	1	1	1	1	1	1	1	1	1	1	1	1	1	1	2	
44	GASKET, VINYL	60610303	1	1	1	1	1	1	1	1	1	1	1	1	1	1	1	1	1	1	
*	HARDWARE BAG(SCREWS)	60846017																			1
*	HARDWARE BAG(SCREWS)	60846016	1	1	1	1	1	1	1	1	1	1	1	1	1	1	1	1	1	1	1
45	GASKET, CHASSIS	61717301	1	1	1	1	1	1	1	1	1	1	1	1	1	1	1	1	1	1	
45	GASKET, WINDOW	60073300	1		1	1	1	1	1	1	1	1	1	1	1	1	1	1	1	1	
*	CARTON, SHIPPING	61839800	1												1	1	1	1	1	1	
*	PAD, SHIPPING	61839500	1	1	1	1	1	1	1	1	1			1	1	1	1	1	1	1	1
*	PAD, FRONT SUPPORT	61839700	1	1	1	1	1	1	1	1	1			1	1	1	1	1	1	1	1
*	PAD, SHIPPING TOP	61839600	1	1	1	1	1	1	1	1	1			1	1	1	1	1	1	1	1
*	CARTON, SHIPPING	61839801	1	1	1	1	1	1	1	1	1	1									1
OPTIONAL ACCESSORY ITEMS																					
*	ACCESSORY PACKAGE	WIKS																			1
*	DRAIN KIT, DC-2	01900235	1	1	1	1	1	1	1	1	1	1	1	1	1	1	1	1	1	1	1
*	START KIT, CAP.RELAY	61008903	1	1	1	1	1	1	1	1	1	1	1	1	1	1	1	1	1	1	1
*	REMOTE CONTROLLER	61826602															1	1		1	1

* PARTS NOT SHOWN

SMALL CHASSIS "S" SERIES PARTS LIST - 230V

REF	DESCRIPTION	PART NO#	ES 230		KS 230		RS 230		SS 230			YS 230	CODE
			ES12J33B-A	ES16J33A-A	KS12J30B-A	KS18J30-A	RS16J30A-A	RS18J30-A	SS12J30D-A	SS16J30A-A	SS18J30R-A	YS12J33-A	
ELECTRICAL PARTS													
1	THERMOSTAT	61822400	1	1								1	120
1	THERMOSTAT	61822500			1	1	1	1					120
*	THERMOSTAT, DEFROST	61350313										1	122
2	ELECTRONIC CTR.	61921104							1	1	1		331
3	RESISTOR	61808001	1	1	1	1	1	1				1	200
*	OVERLOAD	61764521			1	1						1	190
*	OVERLOAD	61764532		1			1	1		1			190
	OVERLOAD	61764540							1				190
4	CAPACITOR	61080536	1		1	1		1	1		1	1	150
4	CAPACITOR	61080537		1			1			1			150
5	SUPPLY CORD	60500049	1	1								1	220
5	SUPPLY CORD	60500051			1	1	1	1	1	1	1		220
6	SWITCH	60607204	1	1								1	130
6	SWITCH	60607203			1	1							130
6	SWITCH	60607205					1	1					130
7	SWITCH (YES - NO)	61806102	1	1	1	1	1	1				1	132
	FAN MOTOR	61871441						1	1		1		110
8	FAN MOTOR	61871429					1			1			110
8	FAN MOTOR	61871437	1		1	1						1	110
8	FAN MOTOR	61871438		1									110
*	SOLENOID	25063600										1	240
8A	HEATER	61878600	1	1								1	210
*	FUSE LINK	61596301	1	1								1	192
*	LIMITER, HEATER	61827900	1	1								1	193
REFRIGERATION SYSTEM PARTS													
9	COMPRESSOR	61716631		1			1			1			600
9	COMPRESSOR	61716628			1							1	600
	COMPRESSOR	61716645	1						1				600
	COMPRESSOR	61716617				1	1				1		600
9	COMPRESSOR	61562828		1			1						600
10	EVAPORATOR COIL	61850005						1					400
10	EVAPORATOR COIL	61850100	1						1			1	400
10	EVAPORATOR COIL	61850101			1								400
	EVAPORATOR COIL	62050005				1					1		400
	EVAPORATOR COIL	62050014		1			1			1			400
11	CONDENSER COIL	61850217			1								410
	CONDENSER COIL	61850221				1		1			1		410
11	CONDENSER COIL	61850302	1				1		1	1			410
11	CONDENSER COIL	61850306										1	410
	CONDENSER COIL	62050302		1									410
*	DRIER, LIQUID	60308101	1	1	1	1	1	1	1	1	1		480
*	DRIER, SUCTION	61828200	1	1	1	1	1	1	1	1	1	1	480
*	CHECK VALVE CAP TUB ASSY	61865301										1	510
*	REVERSING VALVE	61864102										1	500
*	CAPILLARY TUBE	01390212											471
*	CAPILLARY TUBE	03760511											471
*	CAPILLARY TUBE	01390000											471
*	CAPILLARY TUBE	01390005											471
*	CAPILLARY TUBE	03760520											471
	CAPILLARY TUBE ASSY	61927701	1	1			1			1			
	CAPILLARY TUBE ASSY	61927703				1		1			1		
	CAPILLARY TUBE ASSY	61916801			1								
	CAPILLARY TUBE ASSY	61941300							1				

* PARTS NOT SHOWN

SMALL CHASSIS "S" SERIES PARTS LIST - 230V

REF	DESCRIPTION	PART NO#	ES 230		KS 230		RS 230		SS 230			YS 230	CODE
			ES12J33-A	ES16J33A-A	KS12J30B-A	KS18J30A	RS16J30A-A	RS18J30-A	SS12J30D-A	SS16J30A-A	SS18J30R-A	YS12J33-A	
	CHASSIS PARTS												
12	SHROUD, CONDENSER	61803601	1	1	1	1	1	1	1	1	1	1	720
13	FAN BLADE	60542003	1	1	1	1	1	1	1	1	1	1	710
14	BLOWER WHEEL	60610601		1			1	1		1	1		700
14	BLOWER WHEEL	60610603	1		1	1			1			1	700
15	BRACE, COND. SHROUD	61802600	3	3	3	3	3	3	3	3	3	3	722
16	SCROLL	61814902	1	1	1	1	1	1	1	1	1	1	743
17	BLOWER FRONT	61817300	1	1	1	1	1	1	1	1	1	1	742
*	INSULATION, INNER WALL	61816900	1	1	1	1	1	1	1	1	1	1	781
18	INNER WALL	61907300	1	1	1	1	1	1	1	1	1	1	777
19	COVER, TOP	61906700	1	1	1	1	1	1	1	1	1	1	746
20	INSULATION, TOP COVER	61816701	1	1	1	1	1	1	1	1	1	1	781
21	DECK	61817100	1	1	1	1	1	1	1	1	1	1	745
22	AIR FOIL	61820200	1	1	1	1	1	1	1		1	1	744
22	AIR FOIL	61820202								1			744
23	MOUNT, FAN MOTOR	61802500	1	1	1	1	1	1	1	1	1	1	900
24	SHIELD, BOTTOM	61812900	1	1	1	1	1	1	1	1	1	1	999
24	SHIELD, BOTTOM	61812902			1								999
25	BRACKET, HEATER MT.	61818900	1	1								1	999
26	SHIELD, SIDE	61821800	1	1	1	1	1	1	1	1	1	1	999
27	BASE PAN	61809005	1	1									730
27	BASE PAN	61803411			1	1	1	1	1	1	1		730
27	BASE PAN	61809001										1	730
*	DRAIN PAN	61803800	1	1	1	1	1	1	1	1	1	1	840
*	BELLOWS, DRAIN VALVE	60179900	1	1								1	801
*	GRILLE, REAR	61818800	1	1	1	1	1	1	1	1	1	1	771
28	DOOR, SLIDE ASSLY.	61821500	1	1	1	1	1	1	1	1	1	1	810
*	CONNECTOR, SLIDE DOOR	61814800	1	1	1	1	1		1	1	1	1	811
29	PANEL, CTRL. MT.	61807201								1	1		999
29	PANEL, CTRL. MT.	61807200	1	1	1	1	1	1				1	999
30	BRACKET, CAP. MT	61820400	1	1	1	1	1	1	1	1	1	1	999
*	PANEL, LIS	61937200	1	1	1	1	1	1	1	1	1	1	999
31	PARTITION, CTRL. BOX	61802800			1	1	1	1	1	1	1		999
31	PARTITION, CTRL. BOX	61802801	1	1								1	999
*	BUSHING, SUPPLY CORD	60071311	1	1								1	999
*	BUSHING, SUPPLY CORD	60071316	1	1	1	1	1	1	1	1	1	1	999
32	DECORATIVE PANEL	61823300	1	1			1	1	1	1	1	1	999
	DECORATIVE PANEL	61822603					1						999
32	DECORATIVE PANEL	61822600			1	1							999
33	KNOBS, CTRL.	61493905	2	2	2	2	2	2				2	761
29	PANEL, CONTROL SML	61807200	1	1	1	1	1	1				1	999
29	PANEL, CONTROL	61807201							1	1	1		999
*	HOLDER, THERMISTER	61925001							1	1	1		764
*	HOLDER, AIR FILTER	61823000	2	2	2	2	2	2	2	2	2	2	756
*	FILTER, AIR	60865808	1	1	1	1	1	1	1	1	1	1	754
*	CLAMP, SUPPLY CORD	91500301	1	1	1	1	1	1	1	1	1	1	999
*	BRACKET, RESISTO BLOCK	61820600	1	1	1	1	1	1	1	1	1	1	999
*	GROMMET, SUCTION LINE	61807602	1	1	1	1	1	1	1	1	1	1	999
34	GROMMET, COMPRESSOR	61028900	3	3	3	3	3	3	3	3	3	3	790
35	SCREW, COMPRESSOR MT.	91400400	3	3	3	3	3	3	3	3	3	3	999
*	COUNTER WEIGHT	61715800	2	2	2	2	2	2	2	2	2	2	999
36	PLENUM ASSLY.	61810200	1	1	1	1	1	1	1	1	1	1	753
*	KNOB, FRESH AIR & EXHAUST	61809300	1	1	1	1	1	1	1	1	1	1	761

* PARTS NOT SHOWN

SMALL CHASSIS "S" SERIES PARTS LIST - 230V

REF	DESCRIPTION	PART NO#	ES 230		KS 230		RS 230		SS 230			YS 230	CODE
			ES12J33-A	ES16J33A-A	KS12J30B-A	KS18J30A	RS16J30A-A	RS18J30-A	SS12J30D-A	SS16J30A-A	SS18J30R-A		
	CHASSIS PARTS												
37	INTAKE GRILLE	61808903	1	1	1	1	1	1	1	1	1	1	
*	LATCH, INTAKE GRILLE	61989000	2	2	2	2	2	2	2	2	2	2	
38	OUTER SHELL ASSLY	61825700	1	1	1	1	1	1	1	1	1	1	
39	SILL PLATE	61808403	1	1	1	1	1	1	1	1	1	1	
*	CHASSIS GUIDE, SHELL	61819601	2	2	2	2	2	2	2	2	2	2	
*	FRIEDRICH SCRIPT	60169105	1	1	1	1	1	1	1	1	1	1	
*	PUSHNUTS, SCRIPT	91002900	2	2	2	2	2	2	2	2	2	2	
*	ACCESSORY PKGE.	61105004	1	1	1	1	1	1	1	1	1	1	
40	WINGBOARD	60294408	1	1	1	1	1	1	1	1	1		
41	BRACKET, SUPPORT	61109503				2	2	2	2	2	2		
42	ANGLE, WINGBOARD	61819801				2	2	2	2	2	2		
43	ANGLE, TOP	61819701				1	1	1	1	1	1		
44	GASKET, VINYL	60610303	1	1	1	1	1	1	1	1	1	1	
*	HARDWARE BAG(SCREWS)	60846017	1	1								1	
*	HARDWARE BAG(SCREWS)	60846016			1	1	1	1	1	1	1		
45	GASKET, CHASSIS	61717301	1	1	1	1	1	1	1	1	1	1	
45	GASKET, WINDOW	60073300	1	1	1	1	1	1	1	1	1		
*	PAD, SHIPPING TOP	61839600	1	1	1	1	1	1	1	1	1	1	
*	PAD, SHIPPING	61839500	1	1	1	1	1	1	1	1	1		
*	PAD, FRONT SUPPORT	61839700	1	1	1	1	1	1	1	1	1	1	
*	CARTON, SHIPPING	61839800							1	1	1		
*	CARTON, SHIPPING	61839801	1	1	1	1	1	1				1	
OPTIONAL ACCESSORY ITEMS													
*	DRAIN KIT, DC-2	01900235	1	1	1	1	1	1	1	1		1	
*	START KIT, CAP. RELAY	61008903	1	1	1	1	1	1	1	1		1	
*	REMOTE CONTROLLER	61826603							1	1	1		

* PARTS NOT SHOWN

"M" Series
230V
Medium Chassis
Room Air Conditioner Section

**Medium Chassis "M" SERIES CHASSIS PARTS
(EM, KM, RM, SM, & YM)**

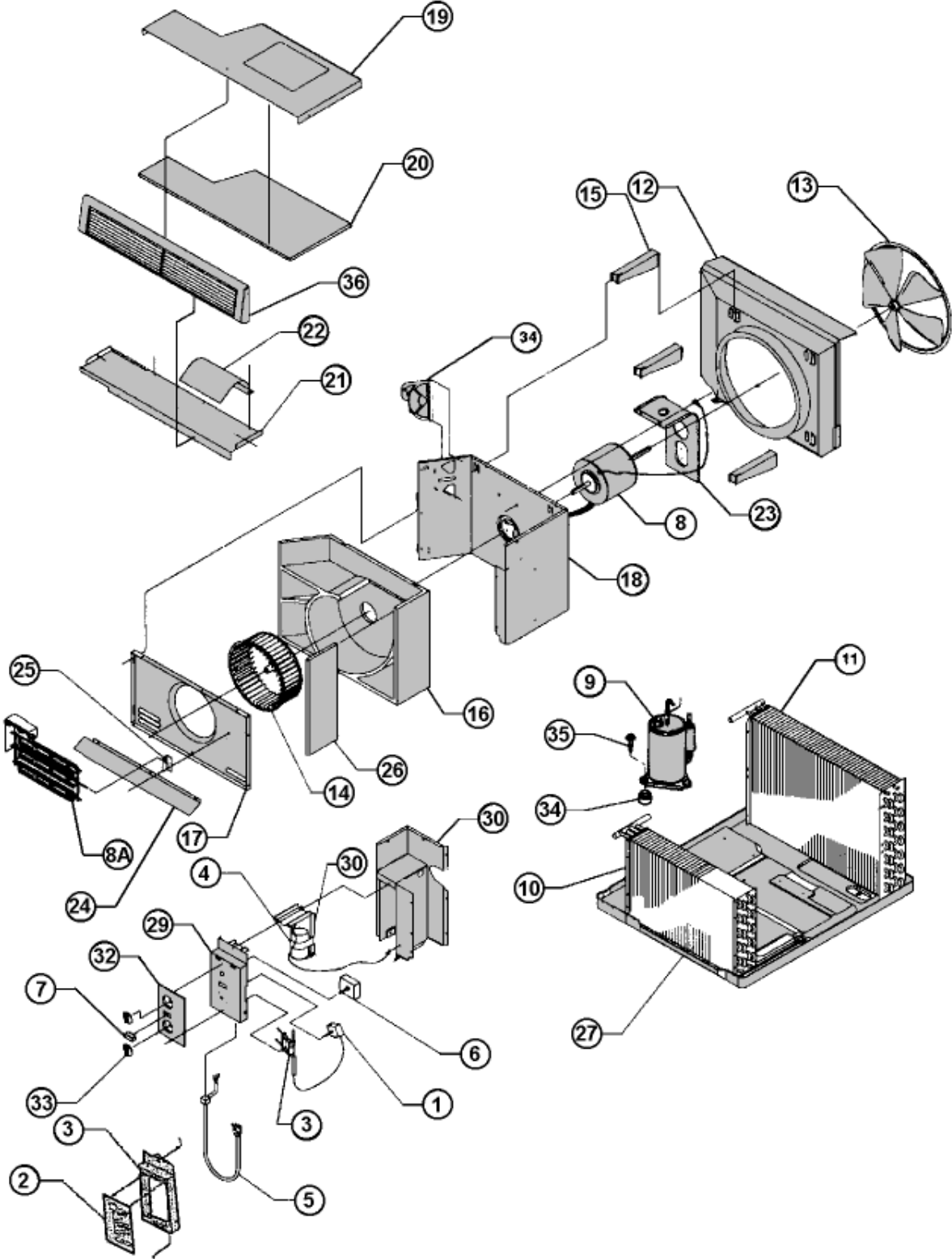

**Medium Chassis "M" SERIES CABINET & MOUNTING PARTS
(EK, EM, KM, RM, SM, YM)**

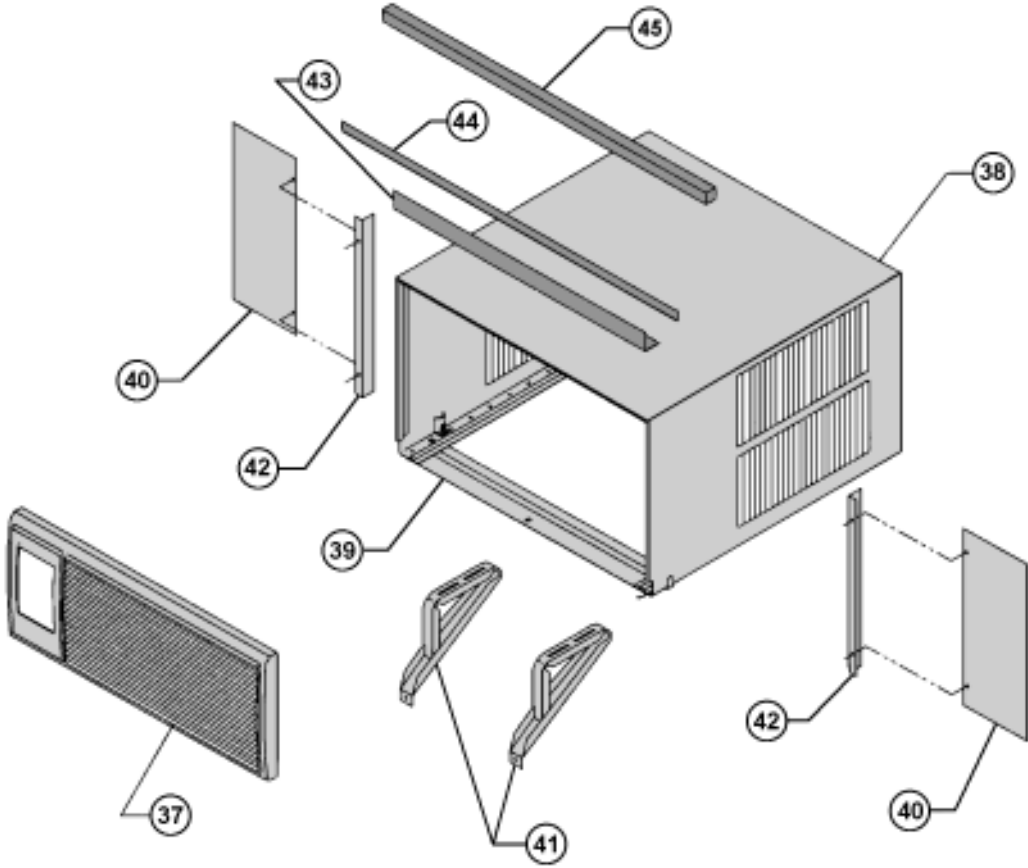

MEDIUM CHASSIS "M" SERIES PARTS LIST

REF	DESCRIPTION	PART NO#	EM 230		KM 230			RM 230		SM 230		YM 230	CODE
			EM18J34B-B	EM18J34B-A	KM18J30C-A	KM20J30-A	KM24J30-A	RM18J30A-A	RM24J30A	SM20J30A	SM24J30A	YM18J34B-A	
	ELECTRICAL PARTS												
1	THERMOSTAT	61822400	1	1									120
1	THERMOSTAT	61828400										1	
1	THERMOSTAT	61828500				1							
1	THERMOSTAT	61822500			1		1	1	1				120
*	THERMOSTAT, DEF.	61350313										1	122
2	ELECTRONIC BOARD	61921104								1	1		331
*	OVERLOAD	61764522	1	1	1				1				190
4	CAPACITOR	61080336											150
4	CAPACITOR	61080557				1			1				150
4	CAPACITOR	61080529					1		1		1		150
4	CAPACITOR	61080536	1	1	1			1					150
4	CAPACITOR	61080553							1			1	150
5	SUPPLY CORD	60500048	1	1								1	220
5	SUPPLY CORD	60500051			1	1		1		1			220
5	SUPPLY CORD	60500049					1		1		1		220
33	RESISTOR	61808001	1	1			1	1	1			1	200
6	SWITCH	60607204	1	1								1	130
6	SWITCH	60607203			1	1	1						130
6	SWITCH	60607205						1	1				130
7	SWITCH (YES - NO)	61806102	1	1	1	1	1	1	1			1	132
8	FAN MOTOR	61871432						1	1	1	1		110
8	FAN MOTOR	61871439				1							110
8	FAN MOTOR	61871439	1	1	1		1					1	110
8	FAN MOTOR	61071481							1	1			110
*	SOLENOID COIL	25063600										1	240
8A	HEATER	61878601	1	1	1							1	210
9	COMPRESSOR	61716603											600
9	COMPRESSOR	61716617	1	1	1			1					600
9	COMPRESSOR	61716652					1		1		1		600
9	COMPRESSOR	61716651				1				1			600
9	COMPRESSOR	61716626										1	600
10	EVAPORATOR COIL	61850011	1	1	1			1					400
10	EVAPORATOR COIL	61850002					1					1	400
10	EVAPORATOR COIL	62050015					1		1		1		400
10	EVAPORATOR COIL	62050016				1				1			400
11	CONDENSER COIL	62050215					1		1		1		400
11	CONDENSER COIL	61850200	1	1	1	1		1		1			410
11	CONDENSER COIL	61850205										1	410
*	DRIER, LIQUID	60308101	1	1	1	1	1	1	1	1	1		480
*	DRIER, SUCTION	61828200	1	1	1	1	1	1	1	1	1	1	480
*	CHECK VALVE cap tub asy	61873501										1	510
*	REVERSING VALVE	61882201										1	500
	CAPILLARY TUBE	61927301	1		1			1					
	CAPILLARY TUBE	61927300		1									
	CAPILLARY TUBE	61944201				1		1		1			
	CAPILLARY TUBE	61942701				1				1			

* PARTS NOT SHOWN

MEDIUM CHASSIS "M" SERIES PARTS LIST

REF	DESCRIPTION	PART NO#	EM 230		KM 230			RM 230		SM 230		YM 230	CODE
			EM18J34B-B	EM18J34B-A	KM18J30C-A	KM20J30-A	KM24J30-A	RM18J30A-A	RM24J30-A	SM20J30A	SM24J30A	YM18J34B-A	
	CHASSIS PARTS												
12	SHROUD, CONDENSER	61804900	1	1	1	1	1	1	1	1	1	1	720
13	FAN BLADE, COND.	60542004	1	1	1	1	1	1	1	1	1	1	710
14	BLOWER WHEEL, EVAP.	60610601	1	1	1	1		1		1			700
14	BLOWER WHEEL, EVAP.	60610605					1	1	1		1	1	700
15	BRACE, COND.SHROUD	61802600	3	3	3	3	3	3	3	3	3	3	722
16	SCROLL	61817500	1	1	1	1	1	1	1	1	1	1	743
17	BLOWER FRONT	61817400	1	1	1	1	1	1	1	1	1	1	742
*	INSULATION, LIS	61816800	1	1	1	1	1	1	1	1	1	1	781
20	INSULATION, TOP	61816701	1	1	1	1	1	1	1	1	1	1	781
	INSULATION, INNERWALL	61816901	1	1	1	1	1	1	1	1	1	1	781
18	INNER WALL	61907200	1	1	1	1	1	1	1	1	1	1	777
19	TOP COVER	61906700	1	1	1	1	1	1	1	1	1	1	746
21	DECK	61817100	1	1	1	1	1	1	1	1	1	1	745
22	AIR FOIL	61820200	1	1	1	1	1	1	1	1	1	1	744
24	SHIELD, BOTTOM	61812900											999
24	SHIELD, BOTTOM	61812901	1	1	1	1						1	999
26	SHIELD, SIDE	61821801	1	1	1	1						1	999
25	BRACKET, HTR	61818900	1	1	1	1						1	730
27	BASE PAN	61809005	1	1	1								730
27	BASE PAN	61803411			1	1	1	1	1	1	1		730
27	BASE PAN	61809005	1	1								1	
*	BELLOWS, DRAIN VALVE	60179900	1	1	1	1	1	1		1	1	1	801
*	DRAIN PAN, EVAP.	61803800	1	1	1	1	1	1	1	1	1	1	840
*	GRILLE, REAR	61818801	1	1	1	1	1	1	1	1	1	1	771
28	DOOR, SLIDE ASY	61821500	1	1	1	1	1	1	1	1	1	1	810
*	CONNECTOR SLIDE ASY	61814800	1	1	1	1	1	1	1	1	1	1	811

* PARTS NOT SHOWN

MEDIUM CHASSIS "M" SERIES PARTS LIST

REF	DESCRIPTION	PART NO#	EM 230		KM 230			RM 230		SM 230		YM 230	CODE
			EM18J34B-B	EM18J34B-A	KM18J30C-A	KM20J30-A	KM24J30-A	RM18J30A-A	RM24J30-A	SM20J30A	SM24J30A	YM18J34B-A	
*	WIRE CLIP, SLIDE ASSY	60301800	1	1	1	1	1	1	1	1	1	1	999
29	PANEL, CTRL. MOUNT	61811000	1	1	1	1	1	1	1			1	999
29	PANEL, CTRL. MOUNT	61811001								1	1		999
*	PANEL, LIS MED	61937100	1	1	1	1	1	1	1	1	1	1	999
*	PANEL, LIS	61906900	1	1	1	1	1		1	1	1		999
31	PARTITION, CTRL. BOX	61804301	1	1								1	999
31	PARTITION, CTRL. BOX	61804300			1	1	1	1	1	1	1		999
30	BRACKET, CAP. MOUNT	61820400	1	1	1	1	1	1	1	1	1	1	999
*	STRAP, CAP.	61820700	1	1	1	1	1	1	1	1	1	1	999
32	DECORATIVE PANEL	61823300	1	1								1	999
32	DECORATIVE PANEL	61822600			1	1	1						999
32	DECORATIVE PANEL	61822603						1	1				999
33	KNOBS, CRTL.	61493905	2	2	2	2	2	2	2			2	761
*	BRACKET, RESISTOR BLK	61820600	1	1	1	1	1	1	1			1	999
*	BLOCK, RESISTOR	61808001	1	1	1	1	1	1	1			1	999
*	HOLDER, THERMISTOR	61925001								1	1		764
*	HOLDER, AIR FILTER	61823000	2	2	2	2	2	2	2	2	2	2	756
*	FILTER, AIR	60865809	1	1	1	1	1	1	1	1	1	1	754
*	CLAMP, SUPPLY CORD	91500302	1	1	1							1	999
*	CLAMP, SUPPLY CORD	91500301				1	1	1	1	1	1		999
34	GROMMET, COMP.	01150934					3						790
34	GROMMET, COMP.	61028900	3	3	3	3		3	3	3	3	3	790
35	SCREW, COMP.	91400400	3	3	3	3	3	3	3	3	3	3	999
*	COUNTER WEIGHT	61715800	2	2	2	2	2	3	2	2	2	1	999
*	GROMMET, SUCTION LN.	61807600	1	1	1	1	1	1	1	1	1	1	999
23	MOUNT, FAN MOTOR	61804100	1	1	1	1	1	1	1	1	1	1	900

* PARTS NOT SHOWN

MEDIUM CHASSIS "M" SERIES PARTS LIST

REF	DESCRIPTION	PART NO#	EM 230		KM 230			RM 230		SM 230		YM 230	CODE
			EM18J34B-B	EM18J34B-A	KM18J30C-A	KM20J30-A	KM24J30-A	RM18J30A-A	RM24J30-A	SM20J30A	SM24J30A	YM18J34B-A	
	CHASSIS PARTS												
36	PLENIUM ASLY.	61810200	1	1	1	1	1	1	1	1	1	1	753
37	GRILLE, INTAKE	61811103	1	1	1	1	1	1	1	1	1	1	772
*	LATCH, GRILLE INTAKE	61989900	2	2	2	1	2	2	2	2	2	2	999
38	OUTER SHELL	61804605	1	1	1	1	1	1	1	1	1	1	770
39	SILL PLATE	61808403	1	1	1	1	1	1	1	1	1	1	999
*	CHASSIS GUIDE, SHELL	61819601	2	2	2	2	2	1	2	2	2	2	999
*	CHASSIS RETAINER	61826400	1	1	1	1	1	1	1	1	1	1	999
*	FRIEDRICH SCRIPT	60169105	1	1	1	1	1	1	1	1	1	1	999
*	PUSHNUTS, SCRIPT	91002900	2	2	2	2	2	2	2	2	2	2	999
*	ACCESSORY PKGE.	61105005					1	1	1	1	1		999
40	WINGBOARD	60294409					1	1	1	1	1		999
*	HARDWARE (SCREWS)	60846017	1	1	1							1	999
*	HARDWARE (SCREWS)	60846016				1	1	1	1	1	1		999
45	GASKET, CHASSIS	61717301	1	1	1	1	1	1	1	1	1	1	780
45	GASKET, WINDOW	60073300					1	1	1	1	1		780
46	GASKET, VINYL	60610303				1	1	1	1	1	1		780
*	CARTON, SHIPPING	61839803								1	1		999
*	CARTON, SHIPPING	61839804	1	1	1	1	1	1	1			1	999
*	PAD, SHIPPING TOP	61839600	1	1	1		1	1	1	1	1	1	999
*	PAD, FRONT SUPPORT	61839700	1	1	1		1	1	1	1	1	1	999
*	PAD, SHIPPING	61839900	2	2	2		2	2	2	2	2	2	999
*	PAD, SHIPPING	61839500				1	1		1	1	1		999
*	PAD, SHIPPING	61840001		1								1	999
41	BRACKET, SUPPORT	61109503	2	2	2	2	2	2	2	2	2		999
43	ANGLE, TOP SUPPORT	61819701				1	1	1	1	1	1		999
42	ANGLE, WINGBOARDS	61819803				2	2	2	2	2	2		999
OPTIONAL ACCESSORY ITEMS													
*	DRAIN KIT, DC-2	01900235	1	1	1		1	1	1	1	1	1	
*	START KIT, CAP.\RELAY	61008903	1	1	1		1	1	1	1	1	1	
*	REMOTE CONTROLLER	61826602								1	1		

* PARTS NOT SHOWN

**"L" Series
Large Chassis
Room Air Conditioner Section**

LARGE CHASSIS "L" SERIES CHASSIS PARTS (SL, EL, & YL)

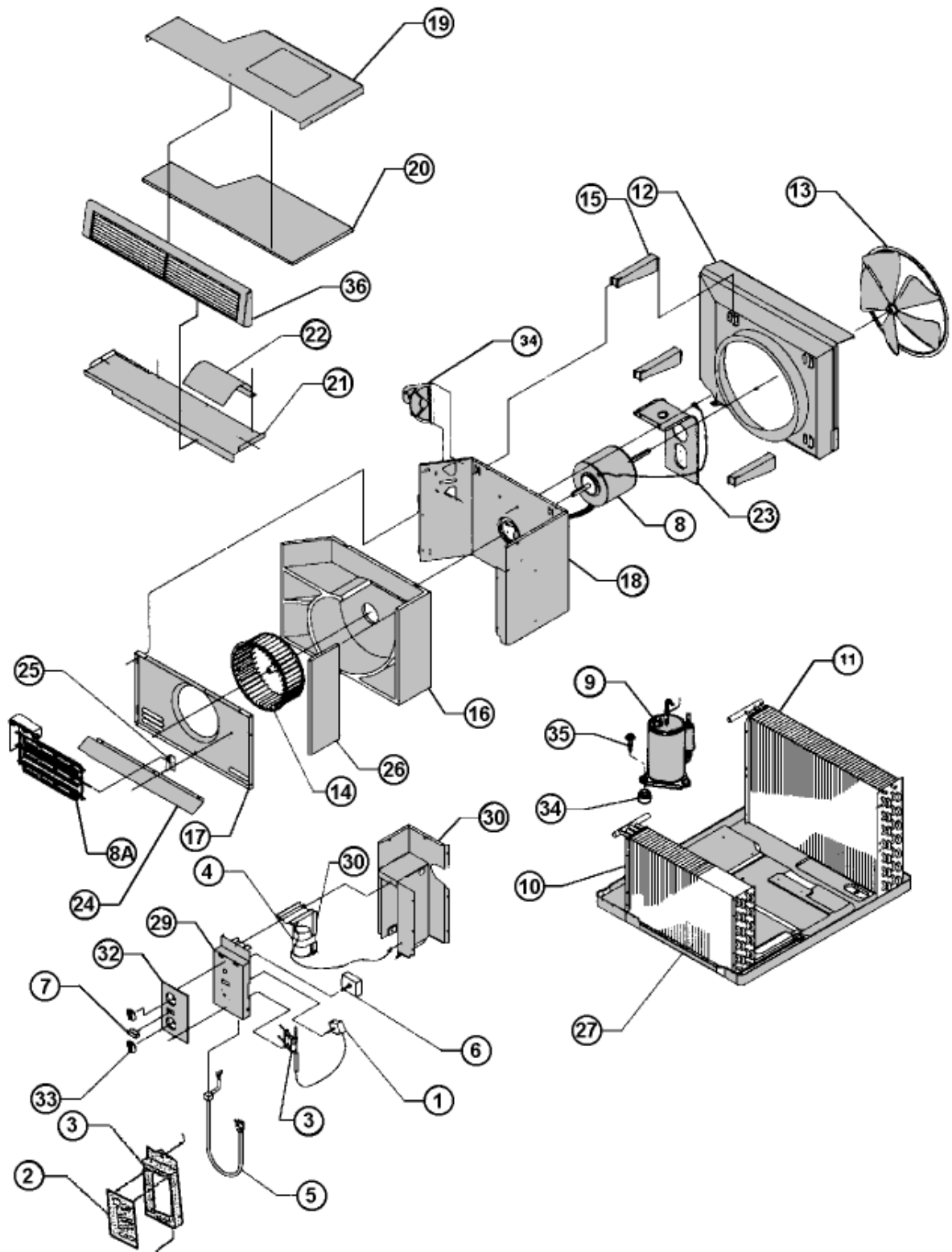

LARGE CHASSIS "L" SERIES CABINET & MOUNTING PARTS (SL, EL, & YL)

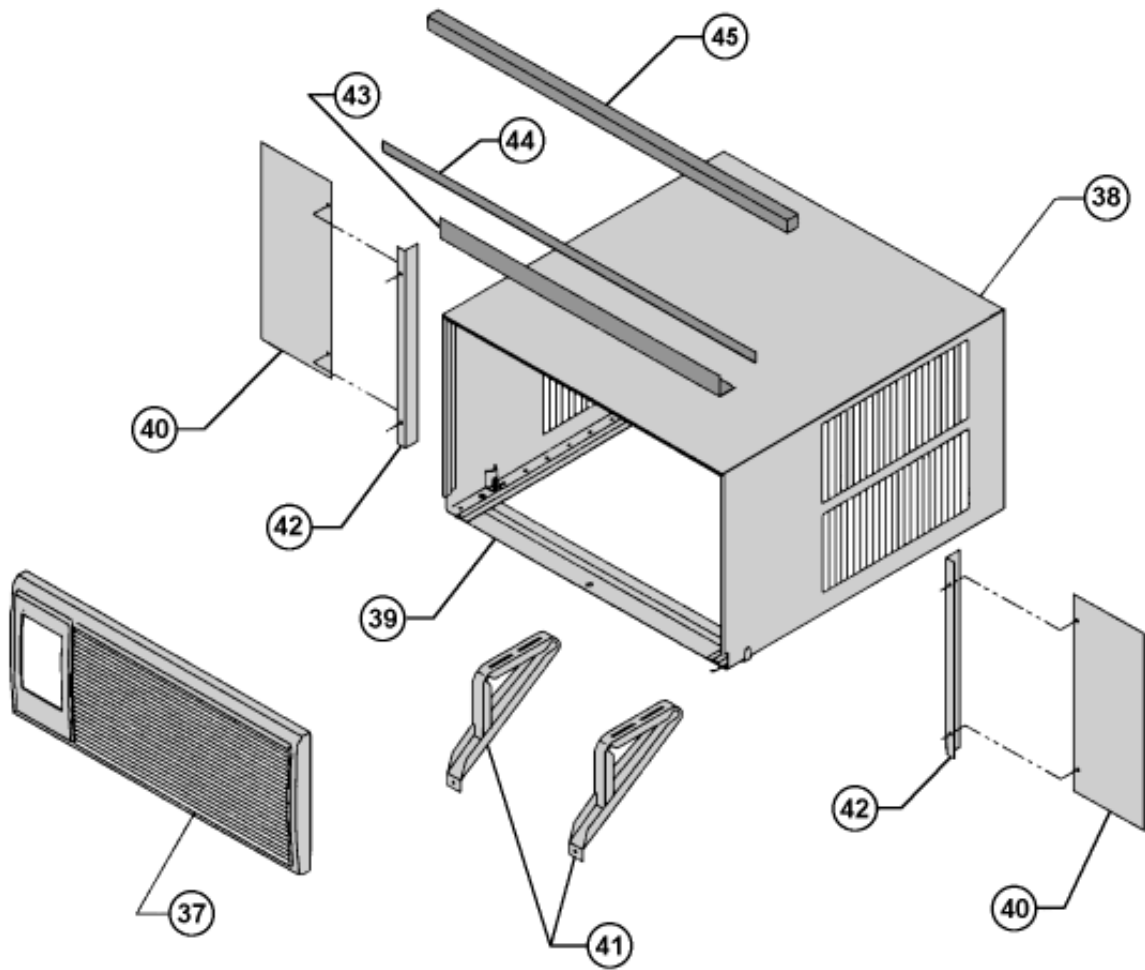

LARGE CHASSIS "L" SERIES PARTS LIST

REF	DESCRIPTION	PART #	SL 230				EL 230			YL 230		CODE
			SL25J30A	SL28J30B-A	SL35J30-A	SL35J30-B	EL25J35-A	EL35J35-A	EL35J35-B	YL24J35C-A	YL24J35C-B	
	ELECTRICAL PARTS											
1	THERMOSTAT	61828500	1		1	1					120	
	THERMOSTAT	61822400				1				1	1	
1	THERMOSTAT	61822500		1							120	
	THERMOSTAT	61828400					1	1				
*	THERMOSTAT, DEF.	61350313								1	1	
4	CAPACITOR	61080529	1			1				1	1	
4	CAPACITOR	61080557		1							150	
4	CAPACITOR	61080357									150	
4	CAPACITOR	61080533									150	
4	CAPACITOR	61080556									150	
4	CAPACITOR	61080551									150	
4	CAPACITOR	61080564			1	1		1	1		150	
4	CAPACITOR	61080567		1							150	
5	SUPPLY CORD	60500049	1	1							220	
5	SUPPLY CORD	60500048									220	
5	SUPPLY CORD	60500055			1	1	1	1	1	1	220	
3	RESISTOR	61808001	1	1	1	1	1	1	1	1	200	
6	SWITCH	60607203	1	1	1	1					130	
6	SWITCH	60607204					1	1	1	1	130	
7	SWITCH (YES - NO)	61806102	1	1	1		1	1		1	132	
	FAN MOTOR	61871446				1			1			
8	FAN MOTOR	61871447	1	1			1			1	110	
8	FAN MOTOR	61071484									110	
8	FAN MOTOR	61871434			1			1			110	
8	FAN MOTOR	61871435									110	
*	SOLENOID COIL	25063600								1	1	
8A	HEATER	61878602					1	1	1	1	210	

*PARTS NOT SHOWN

LARGE CHASSIS "L" SERIES PARTS LIST

REF	DESCRIPTION	PART #	SL 230				EL 230			YL 230		CODE
			SL25J30A	SL28J30B-A	SL35J30-A	SL35J30-B	EL25J35-A	EL35J35-A	EL35J35-B	YL24J35C-A	YL24J35C-B	
	REFRIGERATION PARTS											
9	COMPRESSOR	61716652	1				1			1	1	600
9	COMPRESSOR	61716650		1								600
9	COMPRESSOR	61716632			1	1		1	1			600
9	COMPRESSOR	61716634										600
9	COMPRESSOR	61818702										600
10	EVAPORATOR COIL	62050001		1	1	1		1	1			400
10	EVAPORATOR COIL	61850003	1				1			1	1	400
10	EVAPORATOR COIL	61850004										400
11	CONDENSER COIL	61850220	1				1					410
11	CONDENSER COIL	61850209		1								410
	CONDENSER COIL	61850201			1	1		1	1			
11	CONDENSER COIL	61850202										410
11	CONDENSER COIL	61850203								1	1	410
*	DRIER, LIQUID	60308101	1	1	1	1	1	1	1			480
*	DRIER, SUCTION	61828201	1	1	1	1						480
*	CHECK VALVE CAPILLARY TUBE ASSY	61886500								1	1	510
*	REVERSING VALVE	61886200								1		500
	CAPILLARY TUBE ASSY WITH FILTER	61886001			1	1		1	1			
*	CAPILLARY TUBE ASSY WITH FILTER	61945500	1				1					
	CAPILLARY TUBE ASSY WITH FILTER	61941500		1								

* PARTS NOT SHOWN

LARGE CHASSIS "L" SERIES PARTS LIST

REF	DESCRIPTION	PART #	SL 230				EL 230			YL 230		CODE
			SL25J30A	SL28J30B-A	SL35J30-A	SL35J30-B	EL25J35-A	EL35J35-A	EL35J35-B	YL24J35C-A	YL24J35C-B	
12	SHROUD, CONDENSER	61807700	1	1	1	1	1	1	1	1	1	720
*	SHROUD, W/SUMP LRG	61807701	1	1	1	1	1	1	1	1	1	720
	FAN BLADE, COND.	60542001			1			1				
13	FAN BLADE, COND.	60542007	1	1		1	1		1	1	1	710
14	BLOWER WHEEL, EVAP.	60610602	1	1			1			1	1	700
14	BLOWER WHEEL, EVAP.	60610609			1	1		1	1			700
15	BRACE, COND.SHROUD	61810000	3	3	3	3	3	3	3	3	3	722
16	SCROLL	61818100	1	1	1	1	1	1	1	1	1	743
17	BLOWER FRONT	61817800	1	1	1	1	1	1	1	1	1	742
*	INSULATION, LIS LRG	61818300	1	1	1	1	1	1	1			781
*	INSULATION, LIS	61818300	1	1	1	1	1	1	1	1	1	781
20	INSULATION, TOP	61818201	1	1	1	1	1	1	1	1	1	781
*	INSULATION, INNERWALL	61816902	1	1	1	1	1	1	1	1	1	781
18	INNER WALL	61907100	1	1	1	1	1	1	1	1	1	777
19	TOP COVER	61906600	1	1	1	1	1	1	1	1	1	746
21	DECK	61818000	1	1	1	1	1	1	1	1	1	745
22	AIR FOIL	61820201	1	1	1	1	1	1	1	1	1	744
24	SHIELD, BOTTOM	61813501					1			1	1	999
24	SHIELD, BOTTOM	61813502						1	1			999
26	SHIELD, SIDE	61821900					1	1	1	1	1	999
25	BRACKET, HTR	61818900					1	1	1	1	1	999
27	BASE PAN	61807101			1	1						730
27	BASE PAN	61807104	1	1								730
27	BASE PAN	61809501						1	1			730
27	BASE PAN	61809503					1			1	1	730
*	BELLOWS, DRAIN VALVE	60179900					1	1	1	1	1	801
*	DRAIN PAN, EVAP.	61807400	1	1	1	1	1	1	1	1	1	840
*	GRILLE, REAR	61818802	1	1	1	1	1	1	1	1	1	771
28	DOOR, SLIDE ASY	61821500	1	1	1	1	1	1	1	1	1	810
*	CONNECTOR SLIDE ASY	61814801	1	1	1	1	1	1	1	1	1	811
*	WIRE CLIP, SLIDE ASSY	60301800	2	2	2	2	2	2	2	2	2	999
29	PANEL, CTRL. MOUNT	61806900	1	1	1	1	1	1	1	1	1	999
*	PANEL, LIS	61906800	1		1	1	1	1	1	1	1	999
*	PANEL, LIS	61906802		1								999
*	PANEL, LIS LRG	61937000	1	1	1	1	1	1	1			999
31	PARTITION, CTRL. BOX	61807000	1	1	1	1						999
31	PARTITION, CTRL. BOX	61807001					1	1	1	1	1	999
30	BRACKET, CAP. MOUNT	61820400	1	1	1	1	1	1	1	1	1	999
*	STRAP, CAP.	61820702		1	1	1						999
*	STRAP, CAP.	61820700	1				1	1	1	1	1	999
32	DECORATIVE PANEL	61822600	1	1	1	1						999
32	DECORATIVE PANEL	61823300					1	1	1	1	1	999
33	KNOBS, CRTL.	61493905	2	2	2	2	2	2	2	2	2	761
*	BRACKET, RESISTOR BLK	61820600	1	1	1	1	1	1	1	1	1	999
23	MOUNT, FAN MOTOR	61806700	1	1	1	1	1	1	1	1	1	900
*	HARNESS, FAN MOTOR	61820800	1	1	1	1	1	1	1	1	1	999
*	HOLDER, AIR FILTER	61823000	2	2	2	2	2	2	2	2	2	756
*	FILTER, AIR	60865810	1	1	1	1	1	1	1	1	1	754
*	CLAMP, SUPPLY CORD	91500301	1	1		1						999
*	CLAMP, SUPPLY CORD	91500302			1	3	1	1	1	1	1	999
34	GROMMET, COMP.	01150934	3	3	3	3	3	3	3	3	3	790
35	SCREW, COMP.	91400400	3	3	3	3	3	3	3	3	3	999
*	RETAINER, CHASSIS	61826400	1	1	1	1	1	1	1	1	1	999
*	COUNTER WEIGHT	61715800	2	2	2	2	2	2	2	2	2	999
*	GROMMET, SUCTION LN.	61807601	1	1	1	1	1	1	1	1	1	999

*PARTS NOT SHOWN

LARGE CHASSIS "L" SERIES PARTS LIST

REF	DESCRIPTION	PART #	SL 230				EL 230			YL 230		CODE
			SL25J30A	SL28J30B-A	SL35J30-A	SL35J30-B	EL25J35-A	EL35J35-A	EL35J35-B	YL24J35C-A	YL24J35C-B	
	CHASSIS PARTS											
36	PLENIUM ASLY.	61810500	1	1	1	1	1	1	1	1	1	753
37	GRILLE, INTAKE	61810400	1	1	1	1	1	1	1	1	1	772
*	LATCH, GRILLE INTAKE	61819900	2	2	2	2	2	2	2	2	2	772
38	OUTER SHELL	61825702	1	1	1	1	1	1	1	1	1	770
39	SILL PLATE	61808401	1	1	1	1	1	1	1	1	1	999
*	CHASSIS GUIDE, SHELL	61819601	2	2	2	2	2	2	2	2	2	999
*	CHASSIS RETAINER	61826400	1	1	1	1	1	1	1	1	1	999
*	FRIEDRICH SCRIPT	60169105	1	1	1	1	1	1		1	1	999
*	PUSHNUTS, SCRIPT	91002900	2	2	2	2	2	2	2	2	2	999
*	ACCESSORY PKGE.	61105003	1	1	1	1						999
40	WINGBOARD	60294410	1	1	1	1						999
*	HARDWARE (SCREWS)	60846016	1	1	1	1						999
*	HARDWARE (SCREWS)	60846017					1	1	1	1	1	999
45	GASKET, CHASSIS	61717301	1	1	1	1	1	1	1	1	1	780
45	GASKET, WINDOW	60073300	1	1	1	1						780
44	GASKET, VINYL	60610303	1	1	1	1						780
*	CARTON, SHIPPING	61839806	1	1	1	1	1	1	1	1	1	999
*	PAD, SHIPPING TOP	61839601	1	1	1	1	1	1	1	1	1	999
*	PAD, FRONT SUPPORT	61839701	1	1	1	1	1	1	1	1	1	999
*	PAD, SHIPPING	61839501	1	1	1	1	1	1	1	1	1	999
*	SUPPORT, SHIPPING	61839901	2	2	2	2	2	2	2	2	2	999
*	SPACER, SHIPPING	61915100	2	2	2	2	2	2	2	2	2	999
41	BRACKET, SUPPORT	61109503	2	2	2	2						999
43	ANGLE, TOP SUPPORT	61819703	1	1	1	1						999
42	ANGLE, WINGBOARDS	61819805	2	2	2	2						999
OPTIONAL ACCESSORY ITEMS												
*	DRAIN KIT, DC-2	01900235	1	1	1	1	1	1	1	1	1	
*	START ASSIST KIT	61008903	1	1	1	1	1	1	1	1	1	
*	HARD START KIT	61840900		1	1	1		1	1			

* PARTS NOT SHOWN

**"C" Series
Casement Chassis
Room Air Conditioner Section**

"SC" SERIES CABINET & MOUNTING PARTS

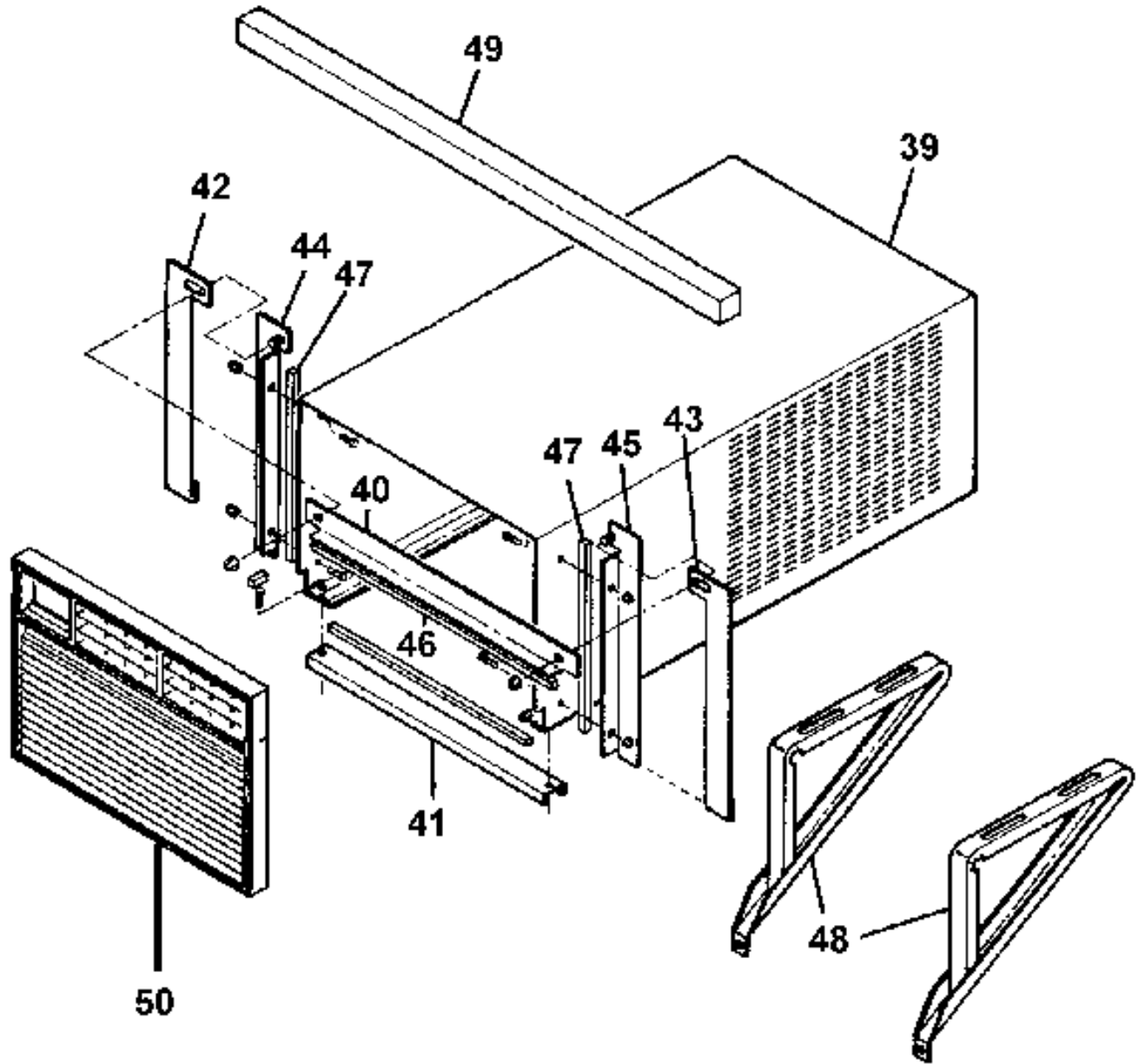

"SC" SERIES CHASSIS PARTS

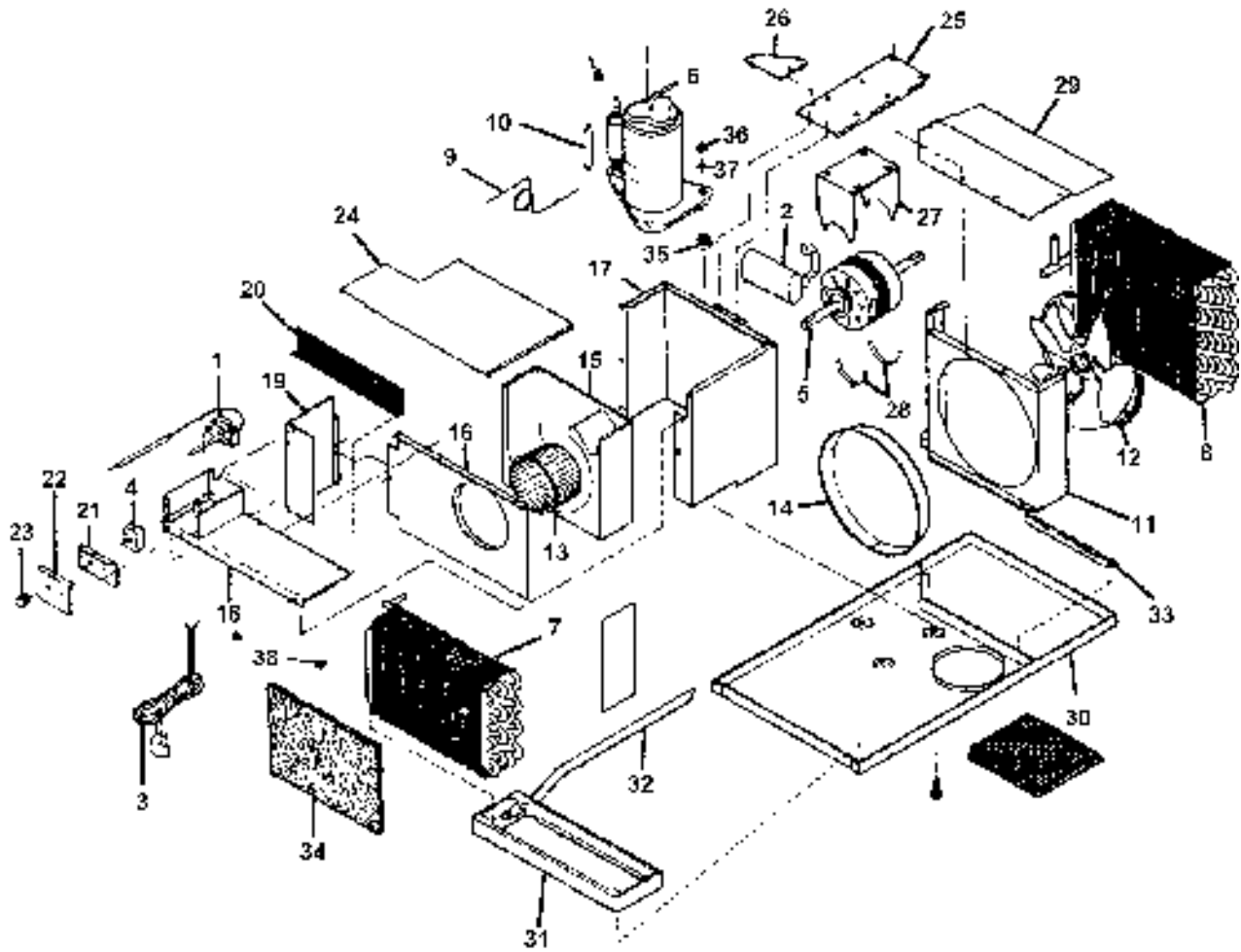

CASEMENT CHASSIS "SC" SERIES PARTS LIST

REF	DESCRIPTION	PART NO#	CASEMENT	CODE
	ELECTRICAL PARTS		SC06H10F	
	THERMOSTAT	61350305	1	120
	OVERLOAD	61764509	1	190
	CAPACITOR	61380392	1	150
	SUPPLY CORD	60500094	1	220
	SWITCH	60895102	1	130
	FAN MOTOR	60571468	1	110
REFRIGERATION SYSTEM PARTS				
	COMPRESSOR	61716602	1	600
	EVAPORATOR COIL	61600204	1	400
	CONDENSER COIL	61600347	1	410
	CAPILLARY TUBE ASSY	61697300	1	471
	FILTER DRIER (LIQUID)	61481300	1	480
CHASSIS SYSTEM PARTS				
	SHROUD, CONDENSER	61076204	1	720
	FAN BLADE, COND.	60063411	1	710
	BLOWER WHEEL, EVAP.	60415201	1	700
	RING, ORIFICE	60232200	1	738
	WRAPPER, BLOWER	61107600	1	741
	FRONT, BLOWER	61076501	1	742
	HOUSING, BLOWER	61076801	1	740
	DECK	61077702	1	745
	PANEL ASSEMBLY, L/S	61077301	1	747
	SCREEN, BLOWER GUARD	61109001	1	774
	BRACKET, CONTROL MOUNTING	61075902	1	999
	PANEL, CONTROL (DECORATIVE)	60416203	1	760
	KNOB, CONTROL	61493903	2	761
	COVER, BULKHEAD ASSLY.	61076302	1	746
	BRACE, COND. SHROUD	61075502	1	722
	COVER, CAPACITOR	61074904	1	999
	MOUNT, MOTOR	61645402	1	900
	CLIP, MOTOR MOUNT	01060445	2	999
	COVER, CONDENSER SHROUD	61076101	1	721
	BASE PAN ASSLY.	61498705	1	730
	DRAIN PAN	60199801	1	840
	TUBE, DRAIN	60203200	1	800
	GUARD, SPLASH	61440300	1	999
	FILTER, AIR	60483801	1	754

* PARTS NOT SHOWN

CASEMENT CHASSIS "SC" SERIES PARTS LIST

REF	DESCRIPTION	PART NO#	CASEMENT	CODE
	CHASSIS SYSTEM PARTS		SC06H10F	
	GROMMET, COMPRESSOR	01150931	3	790
	NUT, COMPRESSOR	91002300	3	999
	WASHER, COMPRESSOR MT.	01423005	3	999
	CLIP, THERMOSTAT	61715100	1	764
	SHELL ASSEMBLY	61580900	1	770
	ANGLE, SHELL TOP SUPPORT	61427001	1	999
	SILL PLATE	61074800	1	999
	ANGLE, WINGBOARD ASSEMBLY (L/S)	61427200	1	999
	ANGLE, WINGBOARD ASSEMBLY (R/S)	61427201	1	999
	ANGLE ASSEMBLY - LEFT SIDE STUD	61427101	1	999
	ANGLE ASSEMBLY - RIGHT SIDE STUD	61427103	1	999
	GASKET, ANGLE TOP SHELL SUPPORT	60467399	1	780
	GASKET, WINGBOARDS	60467377	2	780
	BRACKETS, SUPPORT	61109503	2	999
*	SCRIPT, FRIEDRICH	60169101	1	999
*	NUT, FRIEDRICH SCRIPT	91002900	2	999
	GASKET, CHASSIS	60073301	1	780
	FRONT, DECORATIVE	61077501	1	750
*	HARDWARE KIT	60714305	1	999
	SHIPPING CARTON	61630610	1	999
	PAD, SHIPPING TOP	61630802	1	999
	PAD, SHIPPING TOP	61632000	1	999
	PAD, SHIPPING VERTICAL	61631900	1	999
	PAD, SHIPPING VERTICAL	61631901	1	999
OPTIONAL ACCESSORY ITEMS				
	KIT, INSTALLATION (DOUBLE HUNG WINDOW)	01900241	1	
	ANTI-ICE KIT	60553104	1	
	START KIT	61003803	1	
	INSTALLATION BOOK	92003500	1	
	OPERATION BOOK	92000604	1	
	PARTS MANUAL	92013200	1	
	SERVICE MANUAL	92013100	1	

* PARTS NOT SHOWN

Always Use Factory-Certified Parts.

Friedrich

FRIEDRICH AIR CONDITIONING CO.

Post Office Box 1540 · San Antonio, Texas 78295-1540

4200 N. Pan Am Expressway · San Antonio, Texas 78218-5212

(210) 357-4400 · FAX (210) 357-4480

www.friedrich.com

Printed in the U.S.A.