

This Owner's Manual is provided and hosted by [Appliance Factory Parts](#).



# FRIEDRICH SS12L30-B Owner's Manual

[Shop genuine replacement parts for FRIEDRICH  
SS12L30-B](#)



[Find Your FRIEDRICH Air Conditioner Parts - Select From 1575 Models](#)

----- Manual continues below -----

**Friedrich®**

# 2004 Parts Manual

## Room Air Conditioners



---

# TABLE OF CONTENTS

	<b>PAGE</b>
PORTABLE "Q" SERIES UNITS .....	4-9
SMALL CHASSIS "S" SERIES UNITS (115 & 230 VOLT) .....	10-19
MEDIUM CHASSIS "M" SERIES UNITS (115 & 230 VOLT) .....	20-26
LARGE CHASSIS "L" SERIES UNITS .....	28-33
CASEMENT "C" SERIES UNITS (115 & 230 VOLT) .....	34-38



**"Q" Series  
Portable Chassis  
Room Air Conditioner Section**

# "Q" SERIES CABINET PARTS

NOTE: Items 2, 9A, 13 and 14 are used on "YQ" units only.

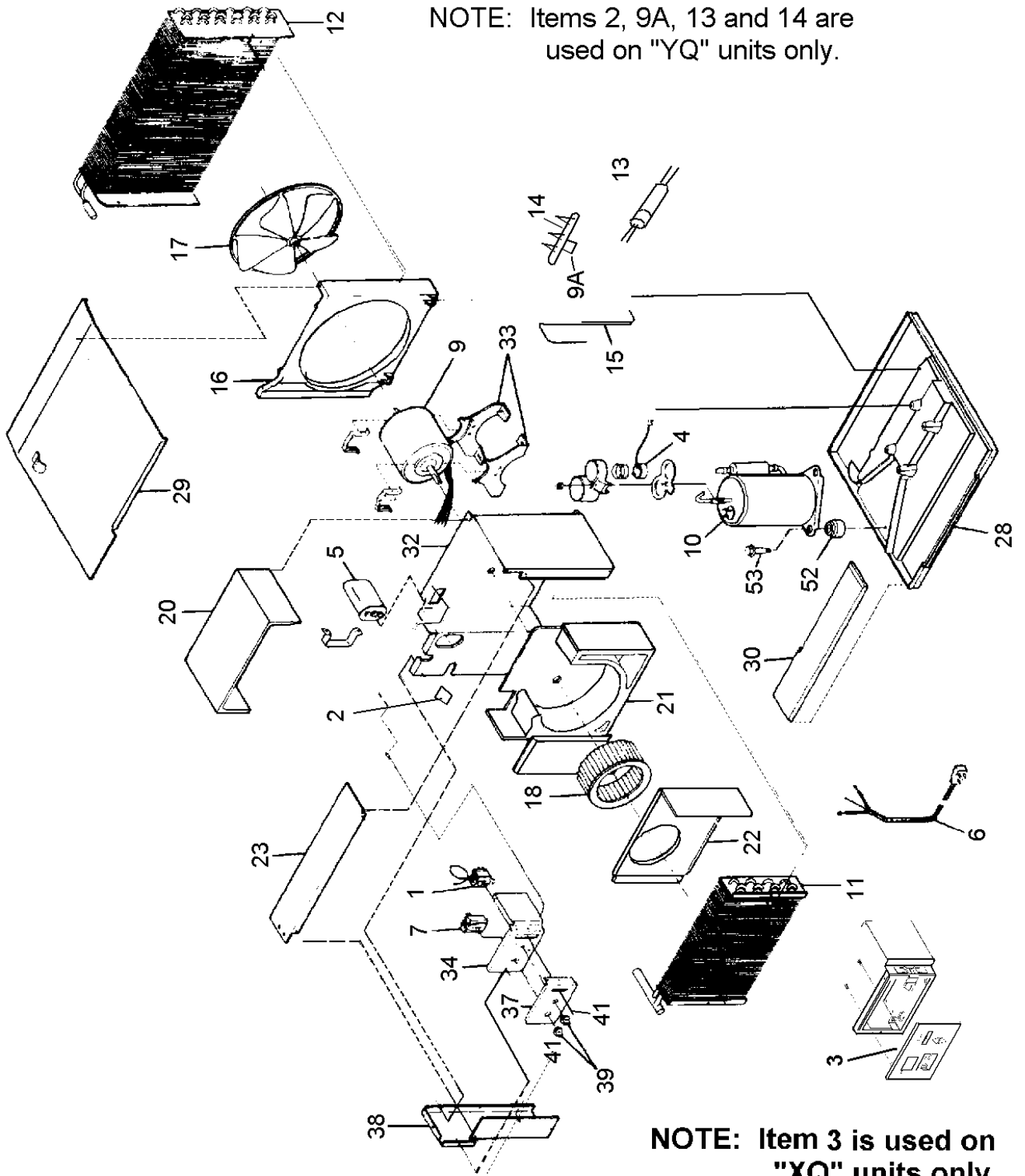

NOTE: Item 3 is used on "XQ" units only.



## PORTABLE "Q" SERIES

REF	DESCRIPTION	PART NO#									CODE
			XQ05J10A-B	XQ06J10A-A	XQ06J10A-B	XQ08J10B-A	XQ10J10-A	XQ10J10-B	EQ08J11A-A	YQ07J10-B	
	<b>ELECTRICAL PARTS</b>										
1	THERMOSTAT	61828401								1	120
1	THERMOSTAT	61822401							1		120
2	THERMOSTAT, DEFROST	60442500								1	122
3	ELECTRONIC BOARD	61921102	1	1	1	1	1				340
3	ELECTRONIC BOARD	61921110						1			340
*	REMOTE CONTROL	61826603	1	1	1	1	1	1			350
*	RESISTOR	61900500							1		200
4	OVERLOAD	61764539	1		1						190
4	OVERLOAD	61764526		1							190
4	OVERLOAD	61764519					1	1			190
4	OVERLOAD	61764507				1			1	1	190
5	CAPACITOR	61080550	1	1	1	1			1	1	150
5	CAPACITOR	61080528					1	1			150
6	SUPPLY CORD	60500065	1	1	1	1	1	1	1	1	220
7	SWITCH ROTARY 6 POS	60441607								1	130
7	SWITCH ROTARY 6 POS	60441610							1		130
*	HEATER	61929601							1		193
9	FAN MOTOR	61871451	1	1	1	1	1	1			110
9	FAN MOTOR	61871452							1	1	110
9A	SOLENOID, REV. VALVE	25063500								1	240
REF	DESCRIPTION	PART NO#									CODE
	<b>REFRIGERATION SYSTEM PARTS</b>										
10	COMPRESSOR	61562832				1			1	1	600
10	COMPRESSOR	61716640					1	1			600
10	COMPRESSOR	61716658		1							600
10	COMPRESSOR	61985100			1						600
10	COMPRESSOR	61985101	1								600
11	EVAPORATOR COIL	61600257		1	1					1	400
11	EVAPORATOR COIL	61600258				1			1		400
11	EVAPORATOR COIL	61600268	1								400
11	EVAPORATOR COIL	62050018					1	1			400
12	CONDENSER COIL	61600352	1								410
12	CONDENSER COIL	61600519		1	1	1			1		410
12	CONDENSER COIL	62050319					1	1			410
12	CONDENSER COIL	61600515								1	410
*	DRIER, LIQUID	61481300	1	1	1	1	1	1	1		480
*	DRIER, SUCTION	61828200								1	480
13	CHECK VALVE	61824400								1	510
14	REVERSING VALVE	25018201								1	500
15	CAPILLARY TUBE	01390595					1	1			471
15	CAPILLARY TUBE	03760545	1	1	1						471
15	CAPILLARY TUBE	03760513				1			1		471
15	CAPILLARY TUBE (HTG)	03760500								1	471
15	CAPILLARY TUBE (CLG)	03760554								1	471

\* PARTS NOT SHOWN

## PORTABLE "Q" SERIES

REF	DESCRIPTION	PART NO#									CODE
			XQ05J10A-B	XQ06J10A-A	XQ06J10A-B	XQ08J10B-A	XQ10J10-A	XQ10J10-B	EQ08J11A-A	YQ07J10-B	
	<b>CHASSIS PARTS</b>										
16	SHROUD, CONDENSER	61627601	1	1	1	1	1	1	1	1	720
17	FAN BLADE	61634001	1	1	1	1	1	1	1	1	710
18	BLOWER WHEEL	60610606	1	1	1					1	700
18	BLOWER WHEEL	60610612				1	1	1	1		700
20	COVER BLOWER	61619503	1	1	1	1	1	1	1	1	745
21	WRAPPER, SCROLL,	61990600	1	1	1	1	1	1	1	1	741
22	FRONT, BLOWER	61928801							1		742
22	FRONT, BLOWER	61990700	1	1	1	1	1	1		1	742
23	DECK, BLOWER	61619405							1		745
23	DECK, BLOWER	61990500	1	1	1	1	1	1		1	745
28	BASE PAN	61626302	1	1	1	1				1	730
28	BASE PAN	61626303					1	1			730
28	BASE PAN	61626304							1		730
29	COVER, UNIT TOP	61715601	1	1	1	1	1	1	1	1	746
30	DRAIN PAN, EVAP.	61638400	1	1	1	1	1	1	1	1	840
32	INNER WALL	61597315	1	1	1	1	1	1			777
32	INNER WALL	61597316								1	777
32	INNER WALL	61597318							1		777
33	FAN MOTOR MOUNT	61776903	1	1	1	1	1	1	1	1	900
*	SCREW, FAN MTR. MT.	21004672	4	4	4	4	4	4	4	4	999
34	CONTROL MT. BRACKET	61619612							1	1	763
34	CONTROL MT. BRACKET	61923900	1	1	1	1	1	1			763

\* PARTS NOT SHOWN

## PORTABLE "Q" SERIES

REF	DESCRIPTION	PART NO#									CODE
			XQ05J10A-B	XQ06J10A-A	XQ06J10A-B	XQ08J10B-A	XQ10J10-A	XQ10J10-B	EQ08J11A-A	YQ07J10-B	
	<b>CHASSIS PARTS</b>										
37	CONTROL DEC. PANEL	61715916							1	1	760
38	PANEL ASSLY, LIS	61924900	1	1	1	1	1	1	1	1	765
39	CONTROL KNOBS	61911600							2	2	761
*	HOLDER, TSTAT BULB	61900500							1	1	764
*	HOLDER, THERMISTER	61925001	1	1	1	1	1	1			764
40	FILTER, AIR	61632310	1	1	1	1	1	1	1	1	754
*	LINK EXHAUST DOOR	61639301	1	1	1	1	1	1			811
*	EXHAUST DOOR	61632202	1	1	1	1	1	1			810
*	WIRE CLIP, EXHAUST	60301800	1	1	1	1	1	1			999
	SLIDE EXHAUST DOOR	61923802	1	1	1	1	1	1			999
43	FRONT, DECORATIVE	61637710	1	1	1	1	1	1	1	1	750
50	SHELL, OUTER ASSY	61625801	1	1	1	1	1	1	1	1	720
51	ANGLE, TOP SUPPORT	61627303	1	1	1	1	1	1			999
52	CHANNEL, SILL	61627201	1	1	1	1	1	1	1	1	999
*	SCRIPT, FRIEDRICH	60169103	1	1	1	1	1	1	1	1	999
51A	GASKET, CHASSIS SEAL	61717300	1	1	1	1	1	1	1	1	780
51B	GASKET, WINDOW SEAL	60073300	1	1	1	1	1	1			780
*	BAG ASSLY (SCREWS)	61778700	1	1	1	1	1	1			999
*	BAG ASSLY (SCREWS)	61778701							1	1	999
REF	DESCRIPTION	PART NO#									CODE
	<b>CHASSIS PARTS</b>										
*	COUNTER WEIGHT	61715800	2	2	2	2	2	2	2	2	999
*	SEAL, FAN MOTOR	60217902	1	1	1	1	1	1	1	1	780
52	GROMMET, COMP. MT.	61028900	3	3	3	3	3	3	3	3	790
53	SCREW, COMP. MT.	91400400	3	3	3	3	3	3	3	3	999
56	CURTAIN ASSLY.	61680203	1	1	1	1	1	1			999
*	CARTON, SHIPPING	61841900	1	1	1	1	1	1	1	1	999
*	PAD SHIPPING TOP	61769700	1	1	1	1	1	1	1	1	999
	PAD SHIPPING BOTTOM	61716400	1	1	1	1	1	1	1	1	999
OPTIONAL ACCESSORIES											
*	ANTI-ICE KIT	61680600							1	1	250
*	START ASSIST (PTCR)	61008903	1	1	1	1	1	1	1	1	160
*	DRAIN KIT, DC-2	O1900235	1	1	1	1	1	1	1	1	
*	INSTALLION BOOK	92003401	1	1	1	1	1	1	1	1	
*	OPERATION BOOK	92000306							1	1	
*	OPERATION BOOK	92011500	1	1	1	1	1	1			
*	PARTS MANUAL	92013200	1	1	1	1	1	1	1	1	
*	SERVICE MANUAL	92013100	1	1	1	1	1	1	1	1	

\* PARTS NOT SHOWN

**"S" Series**  
**115V / 230V**  
**Small Chassis**  
**Room Air Conditioner Section**

## SMALL CHASSIS "S" SERIES CHASSIS PARTS (ES, KS, RS, SS & YS)



**SMALL CHASSIS "S" SERIES CHASSIS PARTS  
(ES, KS, RS, SS & YS)**



## SMALL CHASSIS "S" SERIES PARTS LIST - 115V

	DESCRIPTION	PART NO#	KS 115				RS 115			SS 115				YS 115	CODE	
			KS10E10-A	KS10J10-C	KS12J10B-A	KS15J10-A	RS12J10A-B	RS10J10-C	RS15J10-A	SS08J10R-A	SS09J10C-A	SS10J10AR-A	SS12J10AR-B	SS14J10R-A		SS14J10R-B
1	THERMOSTAT	61822500	1	1	1	1	1	1								120
1	THERMOSTAT	61822400													1	120
*	THERMOSTAT, DEFROST	61350313													1	122
2	ELECTRONIC CTRL.	61921103							1	1	1	1	1			331
2	ELECTRONIC CTRL.	61921111												1		331
*	REMOTE CONTROL	61826603							1		1	1	1	1		350
3	RESISTOR	61808000	1	1	1	1	1	1							1	200
*	OVERLOAD	61764519	1	1	1		1	1			1	1				190
*	OVERLOAD	61764544				1		1					1	1		190
*	OVERLOAD	61764536								1					1	190
*	OVERLOAD	61764507							1							190
4	CAPACITOR	61080533		1												150
4	CAPACITOR	61080535							1							150
4	CAPACITOR	61080554	1					1		1	1				1	150
4	CAPACITOR	61080569			1	1	1	1				1	1	1		150
6	SUPPLYCORD	60500054	1	1			1	1	1	1	1	1			1	220
6	SUPPLYCORD	60500053			1	1			1				1	1		220
6	SWITCH SYS. 5 POS.	60607203	1	1	1	1										130
6	SWITCH SYS. 6 POS.	60607205					1	1	1							130
6	SWITCH SYS. 8 POS.	60607204													1	130
7	SWITCH (YES - NO)	61806102	1	1	1	1	1	1	1						1	132
8	FAN MOTOR	61871431	1	1		1										110
8	FAN MOTOR	61871428						1	1	1						110
8	FAN MOTOR	61871430					1					1				110
8	FAN MOTOR	61871436			1										1	110
8	FAN MOTOR	61871444						1					1	1		110
*	SOLENOID COIL	25063500													1	240

\* PARTS NOT SHOWN

## SMALL CHASSIS "S" SERIES PARTS LIST - 115V

	DESCRIPTION	PART NO#	KS 115				RS 115			SS 115				YS 115	CODE	
			KS10E10-A	KS10J10-C	KS12J10B-A	KS15J10-A	RS12J10A-B	RS10J10-C	RS15J10-A	SS08J10R-A	SS09J10C-A	SS10J10AR-A	SS12J10AR-B	SS14J10R-A		SS14J10R-B
9	COMPRESSOR	62199700		1												600
9	COMPRESSOR	61716641	1				1			1						600
9	COMPRESSOR	61716640			1		1					1				600
9	COMPRESSOR	61716653				1		1					1	1		600
9	COMPRESSOR	61562832							1							600
9	COMPRESSOR	61562608								1					1	600
10	EVAPORATOR COIL	62050014				1		1					1	1		400
10	EVAPORATOR COIL	61850101		1					1	1						400
10	EVAPORATOR COIL	61850100	1		1		1	1			1	1			1	400
11	CONDENSER COIL	61850303		1					1	1						410
11	CONDENSER COIL	61850217			1		1					1				410
11	CONDENSER COIL	61850302	1			1		1			1				1	410
11	CONDENSER COIL	62050302						1					1	1		410
*	DRIER, LIQUID	60308101	1	1	1	1	1	1	1	1	1	1	1	1		480
*	DRIER, SUCTION	61828200													1	480
*	CHECK VALVE	61824400													1	510
*	REVERSING VALVE	25018201													1	500
*	CAPILLARY TUBE	03760520	1	1			1				1					471
*	CAPILLARY TUBE	03760473			1		1					1				471
*	CAPILLARY TUBE	01389903								1						471
*	CAPILLARY TUBE	03760501				1		1					1	1		471
*	CAPILLARY TUBE	03760452									1				1	471
*	CAPILLARY TUBE	03760556													1	471

\* PARTS NOT SHOWN

## SMALL CHASSIS "S" SERIES PARTS LIST - 115V

	DESCRIPTION	PART NO#	KS 115				RS 115			SS 115					YS 115	CODE	
			KS10E10-A	KS10J10-C	KS12J10B-A	KS15J10-A	RS12J10A-B	RS10J10-C	RS15J10-A	SS08J10R-A	SS09J10C-A	SS10J10AR-A	SS12J10AR-B	SS14J10R-A	SS14J10R-B		YS09J10B-A
12	SHROUD, SML W/SUMP LOOP	61803601	1	1	1	1	1	1	1	1	1	1	1	1	1	1	720
13	FAN BLADE, CONDENSER	60542003	1	1	1	1	1	1	1	1	1	1	1	1	1	1	710
14	BLOWER WHEEL, EVAPORATOR	60610603		1	1	1	1		1	1	1		1	1	1	1	700
14	BLOWER WHEEL, EVAPORATOR	60610604	1					1				1					700
15	BRACE, COND. SHROUD	61802600	3	3	3	3	3	3	3	3	3	3	3	3	3	3	722
16	SCROLL	61814902	1	1	1	1	1	1	1	1	1	1	1	1	1	1	743
17	BLOWER FRONT	61817300	1	1	1	1	1	1	1	1	1	1	1	1	1	1	742
*	INSULATION, INNER WALL	61816900	1	1	1	1	1	1	1	1	1	1	1	1	1	1	781
18	INNER WALL	61907300	1	1	1	1	1	1	1	1	1	1	1	1	1	1	777
19	COVER, TOP	61906700	1	1	1	1	1	1	1	1	1	1	1	1	1	1	746
20	INSULATION, TOP COVER	61816701	1	1	1	1	1	1	1	1	1	1	1	1	1	1	781
21	DECK	61817100	1	1	1	1	1	1	1	1	1	1	1	1	1	1	745
22	AIR FOIL	61820200	1	1	1	1	1	1	1	1	1	1	1	1	1	1	744
23	MOUNT, FAN MOTOR	61802500	1	1	1	1	1	1	1	1	1	1	1	1	1	1	900
27	BASE PAN	61803409								1	1						730
27	BASE PAN	61803411	1	1	1	1	1	1	1			1	1	1	1		730
27	BASE PAN	61809003														1	730
*	DRAIN PAN	61803800	1	1	1	1	1	1	1	1	1	1	1	1	1	1	840
*	BELLOWS, DRAIN VALVE	60179903														1	801
*	GRILLE, REAR	61818800	1	1	1	1	1	1	1	1	1	1	1	1	1	1	771
28	DOOR, SLIDE ASSLY.	61821500	1	1	1	1	1	1	1	1	1	1	1	1	1	1	810
*	CONNECTOR, SLIDE DOOR	61814800	1	1	1	1	1	1	1	1	1	1	1	1		1	811
29	PANEL, CTRL. MT.	61807200	1	1	1	1	1	1	1							1	999
29	PANEL, CTRL. MT.	61807201								1	1	1	1	1	1		999
30	BRACKET, CAP. MT	61820400	1	1	1	1	1	1	1	1	1	1	1	1	1	1	999
*	PANEL, L/S	61937200	1	1	1	1	1	1	1	1	1	1	1	1	1	1	999
31	PARTITION, CTRL. BOX	61802800	1	1	1	1	1	1	1	1	1	1	1	1	1	1	999
32	DECORATIVE PANEL	61822603					1	1	1								999
32	DECORATIVE PANEL	61823300														1	999
32	DECORATIVE PANEL	61822600	1	1	1	1											999
33	KNOBS, CTRL.	61493905	2	2	2	2	2	2	2							2	761
*	HOLDER, THERMISTER	61925001								1	1	1	1	1	1		764
*	HOLDER, AIR FILTER	60865900	2	2	2	2	2	2	2	2	2	2	2	2	2	2	756
*	FILTER, AIR	60865808	1	1	1	1	1	1	1	1	1	1	1	1	1	1	754
*	CLAMP, SUPPLYCORD	91500301	1	1	1	1	1	1	1	1	1	1	1	1	1	1	999
*	BRACKET, RESISTO BLOCK	61820600	1	1	1	1	1	1	1							1	999
34	GROMMET, SUCTION LINE	61807602	1	1	1	1	1	1	1	1	1	1	1	1	1		999
34	GROMMET, SUCTION LINE	61807600														1	999
34	GROMMET, COMPRESSOR	61028900	3	3	3	3	3	3	3	3	3	3	3	3	3	3	790
35	SCREW, COMPRESSOR MT.	91400400	3	3	3	3	3	3	3	3	3	3	3	3	3	3	999
*	COUNTER WEIGHT	61715800	2	2	2	2	2	2	2	2	2	2	2	2	2	2	999
36	PLENUM ASSLY.	61810200	1	1	1	1	1	1	1	1	1	1	1	1	1	1	753

\* PARTS NOT SHOWN

## SMALL CHASSIS "S" SERIES PARTS LIST - 115V

	DESCRIPTION	PART NO#	KS 115				RS 115			SS 115				YS 115	CODE	
			KS10E10-A	KS10J10-C	KS12J10B-A	KS15J10-A	RS12J10A-B	RS10J10-C	RS15J10-A	SS08J10R-A	SS09J10C-A	SS10J10AR-A	SS12J10AR-B	SS14J10R-A		SS14J10R-B
*	LEVER, FRESH & EXHAUST	61809200	1	1	1	1	1	1	1	1	1	1	1	1	1	813
*	KNOB, FRESH & EXHAUST	61809300	1	1	1	1	1	1	1	1	1	1	1	1	1	814
37	INTAKE GRILLE	61808903	1	1	1	1	1	1	1	1	1	1	1	1	1	772
*	LATCH, INTAKE GRILLE	61989000	2	2	2	2	2	2	2	2	2	2	2	2	2	
38	OUTER SHELL ASSLY	61825700	1	1	1	1	1	1	1	1	1	1	1	1	1	770
39	SILL PLATE	61808403	1	1	1	1	1	1	1	1	1	1	1	1	1	
*	CHASSIS GUIDE, SHELL	61819601	2	2	2	2	2	2	2	2	2	2	2	2	2	
*	FRIEDRICH SCRIPT	60169103	1	1	1	1	1	1	1	1	1	1	1	1	1	
*	PUSHNUTS, SCRIPT	91002900	2	2	2	2	2	2	2	2	2	2	2	2	2	
*	ACCESSORY PKGE.	61105004	1	1	1	1	1	1	1	1	1	1	1	1	1	
40	WINGBOARD	60294408	1	1	1	1	1	1	1	1	1	1	1	1	1	
41	BRACKET, SUPPORT	61109503	1	2	2	2	2	2	2	2	2	2	2	2	2	
42	ANGLE, WINGBOARD	61819801	2	2	2	2	2	2	2	2	2	2	2	2	2	
43	ANGLE, TOP	61819701	1	1	1	1	1	1	1	1	1	1	1	1	1	
44	GASKET, VINYL. {item #12}	60610303	1	1	1	1	1	1	1	1	1	1	1	1	1	
*	HARDWARE BAG(SCREWS)	60846017							1							1
*	HARDWARE BAG(SCREWS)	60846016	1	1	1	1	1	1	1	1	1	1	1	1	1	
45	GASKET, CHASSIS. {item #14}	61717301	1	1	1	1	1	1	1	1	1	1	1	1	1	1
45	GASKET, WINDOW. {item # 13}	60073300	1	1	1	1	1	1	1	1	1	1	1	1	1	
*	CARTON, SHIPPING	61841901	1	1	1	1	1	1	1	1	1	1	1	1	1	1
*	PAD, SHIPPING	61839500	1	1	1	1	1	1	1	1	1	1	1	1	1	1
*	PAD, FRONT SUPPORT	61839700	1	1	1	1	1	1	1	1	1	1	1	1	1	1
*	PAD, SHIPPING TOP	61839600	1	1	1	1	1	1	1	1	1	1	1	1	1	1
<b>OPTIONAL ACCESSORIES ITEMS</b>																
*	ACCESSORY PACKAGE	WIKS														1
*	DRAIN KIT, DC-2	01900235	1	1	1	1	1	1	1	1	1	1	1	1	1	1
*	START KIT, CAP.RELAY	61008903	1	1	1	1	1	1	1	1	1	1	1	1	1	1
*	ANTI-ICE KIT	61680600	1	1	1	1	1	1	1	1	1	1	1	1	1	1
*	REMOTE CONTROLLER	61826603								1						
*	INSTALLATION BOOK	92003602	1	1	1	1	1	1	1	1	1	1	1	1	1	1
*	OPERATION BOOK	92000306														1
*	OPERATION BOOK	92000505	1	1	1	1										
*	OPERATION BOOK	92006102					1	1	1							
*	OPERATION BOOK	92009002							1	1	1	1	1	1	1	
*	QUICK REF. CARD	92004401							1	1	1	1	1	1	1	
*	PARTS MANUAL	92013200		1	1	1	1	1	1	1	1	1	1	1	1	1
*	SERVICE MANUAL	92013100		1	1	1	1	1	1	1	1	1	1	1	1	1

\* PARTS NOT SHOWN

## SMALL CHASSIS "S" SERIES PARTS LIST - 230V

REF	DESCRIPTION	PART NO#	ES 230		KS 230	RS 230	SS 230		YS 230	CODE
			ES12J33B-A	ES16J33A-A	KS12J30B-A	RS16J30A-A	SS12J30D-A	SS16J30A-A	YS12J33-A	
	<b>ELECTRICAL PARTS</b>									
1	THERMOSTAT	61822400	1	1					1	120
1	THERMOSTAT	61822500			1	1				120
*	RESISTOR	61808001	1	1	1	1			1	200
*	THERMOSTAT, DEFROST	61350313							1	122
2	ELECTRONIC CTR.	61921104					1	1		331
*	OVERLOAD	61764521			1				1	190
*	OVERLOAD	61764532		1		1		1		190
*	OVERLOAD	61764540	1				1			190
4	CAPACITOR	61080536	1	1	1	1	1	1	1	150
5	SUPPLY CORD	60500049	1	1					1	220
5	SUPPLY CORD	60500051			1	1	1	1		220
6	SWITCH, SYS. 8 POS.	60607204	1	1					1	130
6	SWITCH, SYS. 5 POS.	60607203			1					130
6	SWITCH, SYS. 6 POS	60607205				1				130
7	SWITCH (YES - NO)	61806102	1	1	1	1			1	132
8	FAN MOTOR	61871441					1			110
8	FAN MOTOR	61871429				1		1		110
8	FAN MOTOR	61871437	1		1				1	110
8	FAN MOTOR	61871438		1						110
*	SOLENOID	25063600							1	240
8A	HEATER	61878600	1	1					1	210
*	FUSE LINK	61596301	1	1					1	192
*	LIMITER, HEATER	61827901	1	1					1	193
REF	DESCRIPTION	PART NO#	ES 230		KS 230	RS 230	SS 230		YS 230	CODE
	<b>REFRIGERATION PARTS</b>									
			ES12J33B-A	ES16J33A-A	KS12J30B-A	RS16J30A-A	SS12J30D-A	SS16J30A-A	YS12J33-A	
9	COMPRESSOR	61716628			1				1	600
9	COMPRESSOR	61716645	1				1			600
9	COMPRESSOR	61716631		1		1		1		600
10	EVAPORATOR COIL	61850100	1				1		1	400
10	EVAPORATOR COIL	61850101			1					400
10	EVAPORATOR COIL	62050014		1		1		1		400
11	CONDENSER COIL	61850217			1					410
11	CONDENSER COIL	61850302	1				1			410
11	CONDENSER COIL	61850306							1	410
11	CONDENSER COIL	62050302		1		1		1		410
*	DRIER, LIQUID	60308101	1	1	1	1	1	1		480
*	DRIER, SUCTION	61828200							1	480
*	CHECK VALVE	61824400							1	510
*	REVERSING VALVE	25018301							1	500
*	CAPILLARY TUBE	03760513							1	471
*	CAPILLARY TUBE	03760545							1	471
*	CAPILLARY TUBE	03760473	1				1			471
*	CAPILLARY TUBE	01390005		1		1		1		471
*	CAPILLARY TUBE	03760520			1					471

\* PARTS NOT SHOWN

## SMALL CHASSIS "S" SERIES PARTS LIST - 230V

REF	DESCRIPTION	PART NO#	ES 230		KS 230	RS 230	SS 230		YS 230	CODE
			ES12J33-A	ES16J33A-A	KS12J30B-A	RS16J30A-A	SS12J30D-A	SS16J30A-A	YS12J33-A	
	<b>CHASSIS PARTS</b>									
12	SHROUD, CONDENSER	61803601	1	1	1	1	1	1	1	720
13	FAN BLADE	60542003	1	1	1	1	1	1	1	710
14	BLOWER WHEEL	60610601		1		1		1		700
14	BLOWER WHEEL	60610603	1		1		1		1	700
15	BRACE, COND. SHROUD	61802600	3	3	3	3	3	3	3	722
16	SCROLL	61814902	1	1	1	1	1	1	1	743
17	BLOWER FRONT	61817300	1	1	1	1	1	1	1	742
*	INSULATION, INNER WALL	61816900	1	1	1	1	1	1	1	781
18	INNER WALL	61907300	1	1	1	1	1	1	1	777
19	COVER, TOP	61906700	1	1	1	1	1	1	1	746
20	INSULATION, TOP COVER	61816701	1	1	1	1	1	1	1	781
21	DECK	61817100	1	1	1	1	1	1	1	745
22	AIR FOIL	61820200	1	1	1	1	1	1	1	744
23	MOUNT, FAN MOTOR	61802500	1	1	1	1	1	1	1	900
24	SHIELD, BOTTOM	61812900	1	1					1	999
25	BRACKET, HEATER MT.	61818900	1	1					1	999
26	SHIELD, SIDE	61821800	1	1					1	999
27	BASE PAN	61809005	1	1						730
27	BASE PAN	61803411			1	1	1	1		730
27	BASE PAN	61809001							1	730
*	DRAIN PAN	61803800	1	1	1	1	1	1	1	840
*	BELLOWS, DRAIN VALVE	60179903	1	1					1	801
*	GRILLE, REAR	61818800	1	1	1	1	1	1	1	771
28	DOOR, SLIDE ASSLY.	61821500	1	1	1	1	1	1	1	810
*	CONNECTOR, SLIDE DOOR	61814800	1	1	1	1	1	1	1	811
29	PANEL, CTRL. MT.	61807201					1	1		999
29	PANEL, CTRL. MT.	61807200	1	1	1	1			1	999
30	BRACKET, CAP. MT	61820400	1	1	1	1	1	1	1	999
*	PANEL, LIS	61937200	1	1	1	1	1	1	1	999
31	PARTITION, CTRL. BOX	61802800			1	1	1	1		999
31	PARTITION, CTRL. BOX	61802801	1	1					1	999
*	BUSHING, SUPPLY CORD	60071311	1	1					1	999
*	BUSHING, SUPPLY CORD	60071316	1	1	1	1	1	1	1	999
32	DECORATIVE PANEL	61823300	1	1					1	999
32	DECORATIVE PANEL	61822603				1				999
32	DECORATIVE PANEL	61822600			1					999
33	KNOBS, CTRL.	61493905	2	2	2	2			2	761
29	PANEL, CONTROL SML	61807200	1	1	1	1			1	999
29	PANEL, CONTROL	61807201					1	1		999
*	HOLDER, THERMISTER	61925001					1	1		764
*	HOLDER, AIR FILTER	61823000	2	2	2	2	2	2	2	756
*	FILTER, AIR	60865808	1	1	1	1	1	1	1	754
*	CLAMP, SUPPLY CORD	91500302	1	1	1	1	1	1	1	999
*	BRACKET, RESISTO BLOCK	61820600	1	1	1	1			1	999
*	GROMMET, SUCTION LINE	61807602	1	1	1	1	1	1	1	999
34	GROMMET, COMPRESSOR	61028900	3	3	3	3	3	3	3	790
35	SCREW, COMPRESSOR MT.	91400400	3	3	3	3	3	3	3	999
*	FILTER, AIR	60865808	1	1	1	1	1	1	1	754
*	CLAMP, SUPPLY CORD	91500302	1	1	1	1	1	1	1	999
*	BRACKET, RESISTO BLOCK	61820600	1	1	1	1			1	999
*	GROMMET, SUCTION LINE	61807602	1	1	1	1	1	1	1	999
34	GROMMET, COMPRESSOR	61028900	3	3	3	3	3	3	3	790
35	SCREW, COMPRESSOR MT.	91400400	3	3	3	3	3	3	3	999
*	COUNTER WEIGHT	61715800	2	2	2	2	2	2	2	999
36	PLENUM ASSLY.	61810200	1	1	1	1	1	1	1	753
*	KNOB,FRESH AIR & EXHAUST	61809300	1	1	1	1	1	1	1	761

\* PARTS NOT SHOWN

## SMALL CHASSIS "S" SERIES PARTS LIST - 230V

	CHASSIS PARTS		ES12J33-A	ES16J33A-A	KS12J30B-A	RS16J30A-A	SS12J30D-A	SS16J30A-A	YS12J33-A	
37	INTAKE GRILLE	61808903	1	1	1	1	1	1	1	772
*	LATCH, INTAKE GRILLE	61989000	2	2	2	2	2	2	2	
38	OUTER SHELL ASSLY	61825700	1	1	1	1	1	1	1	770
39	SILL PLATE	61808403	1	1	1	1	1	1	1	
*	CHASSIS GUIDE, SHELL	61819601	2	2	2	2	2	2	2	
*	FRIEDRICH SCRIPT	60169105	1	1	1	1	1	1	1	
*	PUSHNUTS, SCRIPT	91002900	2	2	2	2	2	2	2	
40	WINGBOARD	60294408			1	1	1	1		
41	BRACKET, SUPPORT	61109503			2	2	2	2		
42	ANGLE, WINGBOARD	61819801			2	2	2	2		
43	ANGLE, TOP	61819701			1	1	1	1		
44	GASKET, VINYL	60610303	1	1	1	1	1	1	1	
*	HARDWARE BAG(SCREWS)	60846017	1	1					1	
*	HARDWARE BAG(SCREWS)	60846016			1	1	1	1		
45	GASKET, CHASSIS	61717301	1	1	1	1	1	1	1	
45	GASKET, WINDOW	60073300			1	1	1	1		
*	PAD, SHIPPING TOP	61839600	1	1	1	1	1	1	1	
*	PAD, SHIPPING	61839500	1	1	1	1	1	1	1	
*	PAD, FRONT SUPPORT	61839700	1	1	1	1	1	1	1	
*	CARTON, SHIPPING	61841901	1	1	1	1	1	1	1	
<b>OPTIONAL ACCESSORY ITEMS</b>										
*	DRAIN KIT, DC-2	01900235	1	1	1	1	1	1	1	
*	START KIT, CAP.RELAY	61008903	1	1	1	1	1	1	1	
*	REMOTE CONTROLLER	61826603					1	1		
*	INSTALLATION BOOK	92003601	1	1	1	1	1	1	1	
*	OPERATION BOOK	92000304	1	1					1	
*	OPERATION BOOK	92000505			1					
*	OPERATION BOOK	92006102				1				
*	OPERATION BOOK	92000901					1	1		
*	QUICK REF. CARD	92004401					1	1		
*	PARTS MANUAL	92013200	1	1	1	1	1	1	1	
*	SERVICE MANUAL	92013100	1	1	1	1	1	1	1	

\* PARTS NOT SHOWN

**"M" Series**  
**230V**  
**Medium Chassis**  
**Room Air Conditioner Section**

# Medium Chassis "M" SERIES CHASSIS PARTS (EM, KM, RM, SM, & YM)

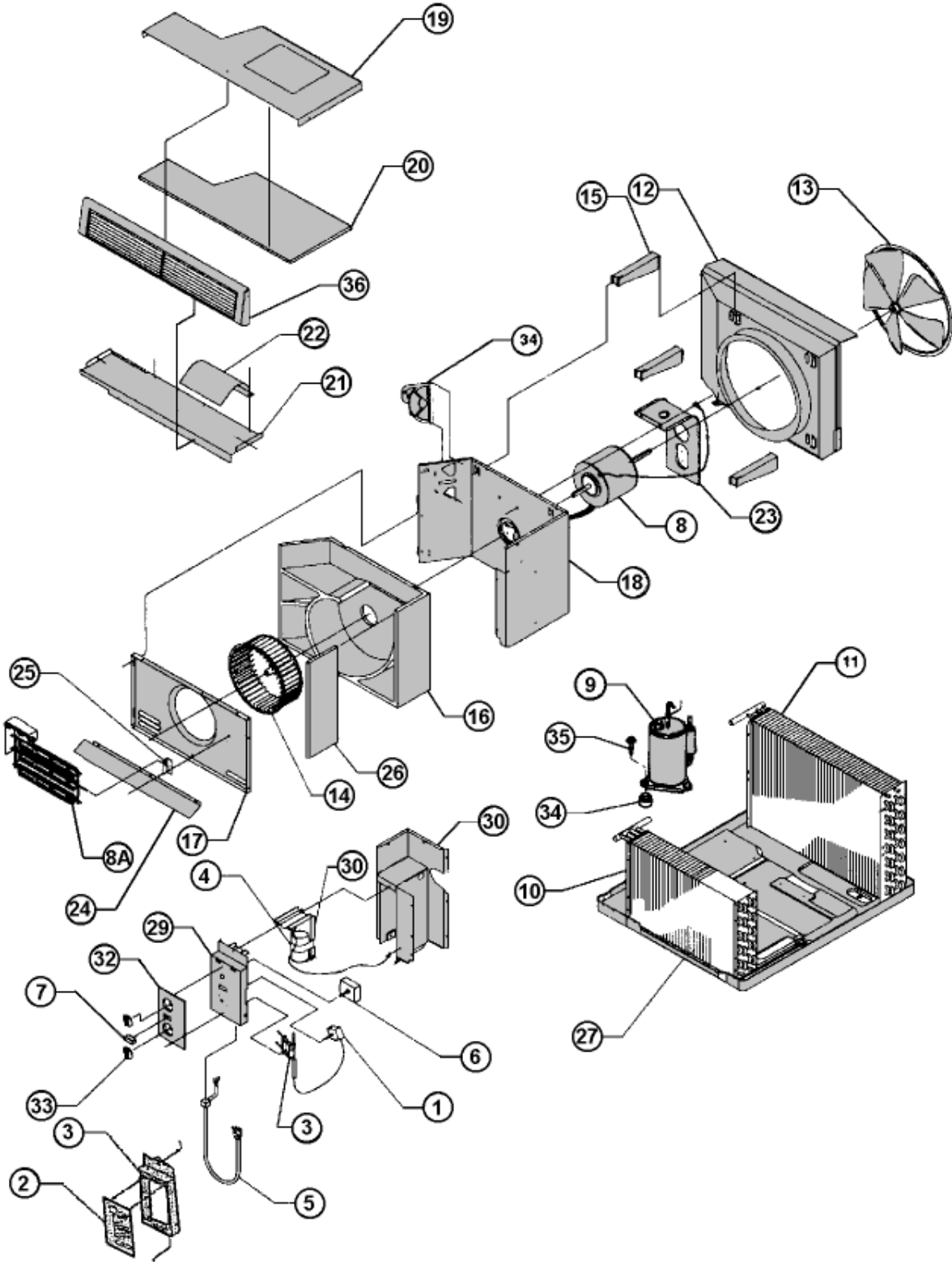

**Medium Chassis "M" SERIES CABINET & MOUNTING PARTS  
(EK, EM, KM, RM, SM, YM)**

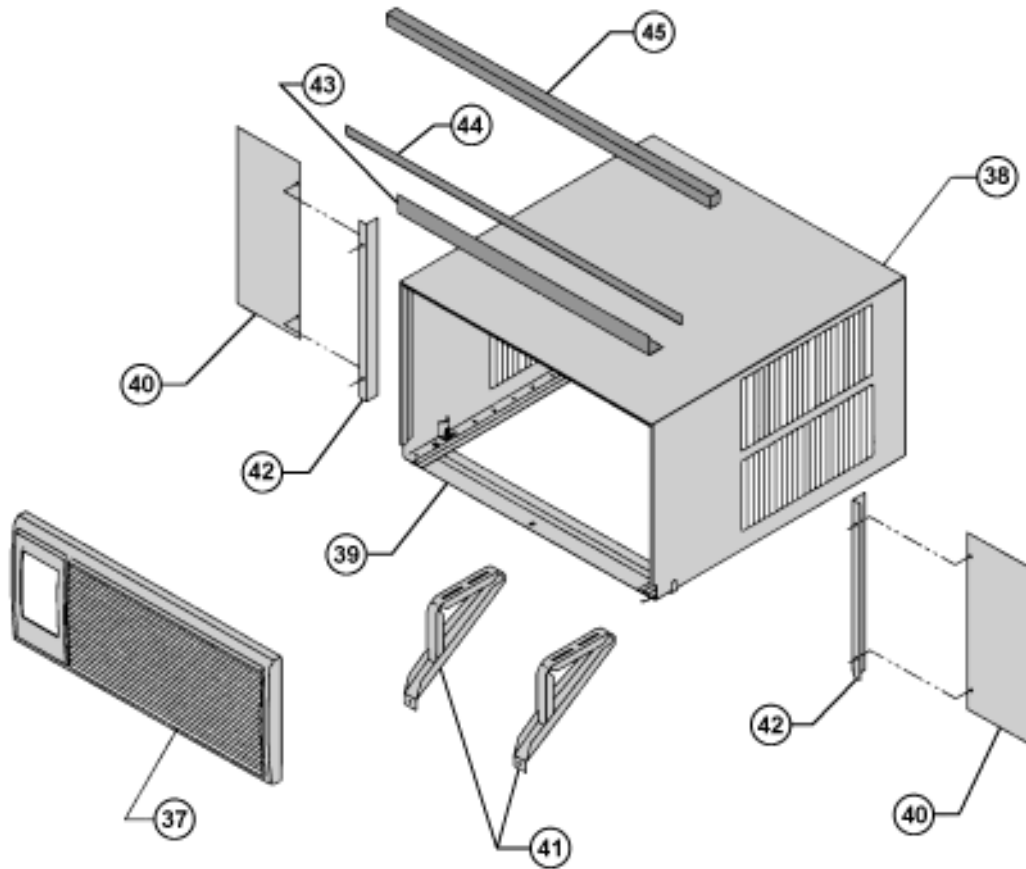

## MEDIUM CHASSIS "M" SERIES PARTS LIST

REF	DESCRIPTION	PART NO#	EM 230	KM 230		RM 230		SM 230				YM 230	CODE
			EM18J34B-B	KM18J30C-A	KM20J30-A	KM24J30-A	RM18J30A-A	RM24J30-A	SM18J30BR-A	SM20J30-A	SM20J30-B	SM24J30-A	
1	THERMOSTAT	61822400	1									1	120
1	THERMOSTAT	61822500		1	1	1	1	1					120
*	RESISTOR	61808001	1	1	1	1	1	1				1	200
*	THERMOSTAT, DEF.	61350313										1	122
2	ELECTRONIC BOARD	61921104							1	1	1	1	331
*	REMOTE CONTROL	61826603							1				350
*	OVERLOAD	61764522										1	190
4	CAPACITOR	61080557			1					1	1		150
4	CAPACITOR	61080529				1		1				1	150
4	CAPACITOR	61080536	1	1			1		1				150
4	CAPACITOR	61080553										1	150
5	SUPPLY CORD	60500048	1									1	220
5	SUPPLY CORD	60500051		1	1		1		1	1	1		220
5	SUPPLY CORD	60500049				1		1				1	220
6	SWITCH SYS. 8 POS.	60607204	1									1	130
6	SWITCH SYS. 5 POS.	60607203		1	1	1							130
6	SWITCH SYS. 6 POS.	60607205					1	1					130
7	SWITCH (YES - NO)	61806102	1	1	1	1	1	1				1	132
8	FAN MOTOR	61871432					1	1	1	1	1	1	110
8	FAN MOTOR	61871439	1	1	1	1						1	110
*	SOLENOID COIL	25063600										1	240
8A	HEATER	61878602	1									1	210

\* PARTS NOT SHOWN

## MEDIUM CHASSIS "M" SERIES PARTS LIST

REF	DESCRIPTION	PART NO#	EM 230	KM 230		RM 230		SM 230				YM 230	CODE
			EM18J34B-B	KM18J30C-A	KM20J30-A	KM24J30-A	RM18J30A-A	RM24J30-A	SM18J30BR-A	SM20J30-A	SM20J30-B	SM24J30-A	
9	COMPRESSOR	61716652				1	1				1		600
9	COMPRESSOR	61716651			1				1	1			600
9	COMPRESSOR	61716617	1	1			1		1				600
9	COMPRESSOR	61716660										1	600
10	EVAPORATOR COIL	61850011	1	1			1		1				400
10	EVAPORATOR COIL	61850002										1	400
10	EVAPORATOR COIL	62050015				1		1			1		400
10	EVAPORATOR COIL	62050016			1				1	1			400
11	CONDENSER COIL	62050215				1		1			1		400
11	CONDENSER COIL	61850200	1	1	1		1		1	1			410
11	CONDENSER COIL	61850205										1	410
*	DRIER, LIQUID	60308101	1	1	1	1	1	1	1	1	1		480
*	DRIER, SUCTION	61828200										1	480
*	CHECK VALVE	61824402										1	510
*	REVERSING VALVE	25018701										1	500
*	CAPILLARY TUBE	01389975	1	1			1		1				471
*	CAPILLARY TUBE	03760411										1	471
*	CAPILLARY TUBE	01389902										1	471
*	CAPILLARY TUBE	03760479			1				1				471
*	CAPILLARY TUBE	03760452				1		1			1		471

\* PARTS NOT SHOWN

## MEDIUM CHASSIS "M" SERIES PARTS LIST

REF	DESCRIPTION	PART NO#	EM 230				KM 230				RM 230				SM 230				YM 230	CODE
			EM18J34B-B	KM18J30C-A	KM20J30-A	KM24J30-A	RK18J30A-A	RM24J30-A	SM18J30BR-A	SM20J30A	SM20J30-B	SM24J30A	YM18J34C-A							
12	SHROUD, CONDENSER	61804901	1	1	1	1	1	1	1	1	1	1	1	1	1	1	1	720		
13	FAN BLADE, COND.	60542004	1	1	1	1	1	1	1	1	1	1	1	1	1	1	1	710		
14	BLOWER WHEEL, EVAP.	60610601	1	1	1		1		1	1	1							700		
14	BLOWER WHEEL, EVAP.	60610605				1		1						1	1			700		
15	BRACE, COND.SHROUD	61802600	3	3	3	3	3	3	3	3	3	3	3	3	3	3	3	722		
16	SCROLL	61817500	1	1	1	1	1	1	1	1	1	1	1	1	1	1	1	743		
17	BLOWER FRONT	61817400	1	1	1	1	1	1	1	1	1	1	1	1	1	1	1	742		
*	INSULATION, L\S	61816800	1	1	1	1	1	1	1	1	1	1	1	1	1	1	1	781		
20	INSULATION, TOP	61816701	1	1	1	1	1	1	1	1	1	1	1	1	1	1	1	781		
*	INSULATION, INNERWALL	61816901	1	1	1	1	1	1	1	1	1	1	1	1	1	1	1	781		
18	INNER WALL	61907200	1	1	1	1	1	1	1	1	1	1	1	1	1	1	1	777		
19	TOP COVER	61906700	1	1	1	1	1	1	1	1	1	1	1	1	1	1	1	746		
21	DECK	61817100	1	1	1	1	1	1	1	1	1	1	1	1	1	1	1	745		
22	AIR FOIL	61820200	1	1	1	1	1	1	1	1	1	1	1	1	1	1	1	744		
24	SHIELD, BOTTOM	61812900	1														1	999		
26	SHIELD, SIDE	61821801	1														1	999		
25	BRACKET, HTR	61818900	1														1	730		
27	BASE PAN	61809005	1														1	730		
27	BASE PAN	61803411		1	1	1	1	1	1	1	1	1	1	1	1	1		730		
*	BELLOWS, DRAIN VALVE	60179903	1														1	801		
*	DRAIN PAN, EVAP.	61803800	1	1	1	1	1	1	1	1	1	1	1	1	1	1	1	840		
*	GRILLE, REAR	61818801	1	1	1	1	1	1	1	1	1	1	1	1	1	1	1	771		
28	DOOR, SLIDE ASY	61821500	1	1	1	1	1	1	1	1	1	1	1	1	1	1	1	810		
*	CONNECTOR SLIDE ASY	61814800	1	1	1	1	1	1	1	1	1	1	1	1	1	1	1	811		
*	WIRE CLIP, SLIDE ASSY	60301800	1	1	1	1	1	1	1	1	1	1	1	1	1	1	1	999		
29	PANEL, CTRL. MOUNT	61811000	1	1	1	1	1	1	1								1	999		
29	PANEL, CTRL. MOUNT	61811001								1	1	1	1					999		
*	PANEL, L\S MED	61937100	1	1	1	1	1	1	1	1	1	1	1	1	1	1	1	999		
30	BRACKET, CAP. MOUNT	61820400	1	1	1	1	1	1	1	1	1	1	1	1	1	1	1	999		
*	STRAP, CAP.	61820700	1	1	1	1	1	1	1	1	1	1	1	1	1	1	1	999		
32	DECORATIVE PANEL	61823300	1														1	999		
32	DECORATIVE PANEL	61822600		1	1	1	1	1	1									999		
33	KNOBS, CRTL.	61493905	2	2	2	2	2	2	2								2	761		
*	BRACKET, RESISTOR BLK	61820600	1	1	1	1	1	1	1								1	999		
*	HOLDER, THERMISTOR	61925001								1	1	1	1					764		
*	HOLDER, AIR FILTER	61823000	2	2	2	2	2	2	2	2	2	2	2	2	2	2	2	756		
*	FILTER, AIR	60865809	1	1	1	1	1	1	1	1	1	1	1	1	1	1	1	754		
*	CLAMP, SUPPLY CORD	91500302	1														1	999		
*	CLAMP, SUPPLY CORD	91500301		1	1	1	1	1	1	1	1	1	1	1	1	1		999		
34	GROMMET, COMP.	61028900	3	3	3	3	3	3	3	3	3	3	3	3	3	3	3	790		
35	SCREW, COMP.	91400400	3	3	3	3	3	3	3	3	3	3	3	3	3	3	3	999		
*	COUNTER WEIGHT	61715800	3	3	2	2	2	3	2	2	2	2	2	2	2	1		999		
*	GROMMET, SUCTION LN.	61807600	1	1	1	1	1	1	1	1	1	1	1	1	1	1	1	999		
23	MOUNT, FAN MOTOR	61804100	1	1	1	1	1	1	1	1	1	1	1	1	1	1	1	900		

\* PARTS NOT SHOWN

## MEDIUM CHASSIS "M" SERIES PARTS LIST

REF	DESCRIPTION	PART NO#	EM 230	KM 230		RM 230		SM 230				YM 230	CODE
			EM18J34B-B	KM18J30C-A	KM20J30-A	KM24J30-A	RM18J30A-A	RM24J30-A	SM18J30BR-A	SM20J30A	SM20J30J-B	SM24J30A	
36	PLENIUM ASLY.	61810200	1	1	1	1	1	1	1	1	1	1	753
37	GRILLE, INTAKE	61811103	1	1	1	1	1	1	1	1	1	1	772
*	LATCH, GRILLE INTAKE	61989000	2	2	2	1	2	2	2	2	2	2	999
38	OUTER SHELL	61825701	1	1	1	1	1	1	1	1	1	1	770
39	SILL PLATE	61808403	1	1	1	1	1	1	1	1	1	1	999
*	CHASSIS GUIDE, SHELL	61819601	2	2	2	2	2	1	2	2	2	2	999
*	CHASSIS RETAINER	61826400	1	1	1	1	1	1	1	1	1	1	999
*	FRIEDRICH SCRIPT	60169103	1	1	1	1	1	1	1	1	1	1	999
*	PUSHNUTS, SCRIPT	91002900	2	2	2	2	2	2	2	2	2	2	999
40	WINGBOARD	60294409		1	1	1	1	1	1	1	1		999
*	HARDWARE (SCREWS)	60846017	1									1	999
*	HARDWARE (SCREWS)	60846016		1	1	1	1	1	1	1	1		999
45	GASKET, CHASSIS	61717301	1	1	1	1	1	1	1	1	1	1	780
45	GASKET, WINDOW	60073300		1	1	1	1	1	1	1	1		780
46	GASKET, VINYL	60610303		1	1	1	1	1	1	1	1		780
*	CARTON, SHIPPING	61841902	1	1	1	1	1	1	1	1	1	1	999
*	PAD, SHIPPING TOP	61839600	1	1	1	1	1	1	1	1	1	1	999
*	PAD, FRONT SUPPORT	61839700	1	1	1	1	1	1	1	1	1	1	999
*	SHIPPING SUPPORT	61839900	2	2	2		2	2	2	2	2	2	999
*	PAD, SHIPPING	61839500	1	1	1	1	1	1	1	1	1	1	999
41	BRACKET, SUPPORT	61109503		2	2	2	2	2	2	2	2		999
43	ANGLE, TOP SUPPORT	61819701		1	1	1	1	1	1	1	1		999
42	ANGLE, WINGBOARDS	61819803		2	2	2	2	2	2	2	2		999
<b>OPTIONAL ACCESSORY ITEMS</b>													
*	DRAIN KIT, DC-2	01900235	1	1	1	1	1	1	1	1	1	1	
*	START KIT, CAP.RELAY	61008903	1	1	1	1	1	1	1	1	1	1	
*	REMOTE CONTROLLER	61826603								1	1	1	
*	PARTS MANUAL	92013200	1	1	1	1	1	1	1	1	1	1	
*	SERVICE MANUAL	92013100	1	1	1	1	1	1	1	1	1	1	
*	INSTALLATION BOOK	92003602	1	1	1	1	1	1	1	1	1	1	
*	OPERATION BOOK	92000306	1										1
*	OPERATION BOOK	92000505		1	1	1							
*	OPERATION BOOK	92006102					1	1					
*	OPERATION BOOK	92009004							1	1	1	1	
*	QUICK REF. CARD	92004401							1	1	1	1	

\* PARTS NOT SHOWN



**"L" Series  
Large Chassis  
Room Air Conditioner Section**

# LARGE CHASSIS "L" SERIES CHASSIS PARTS (SL, EL, & YL)

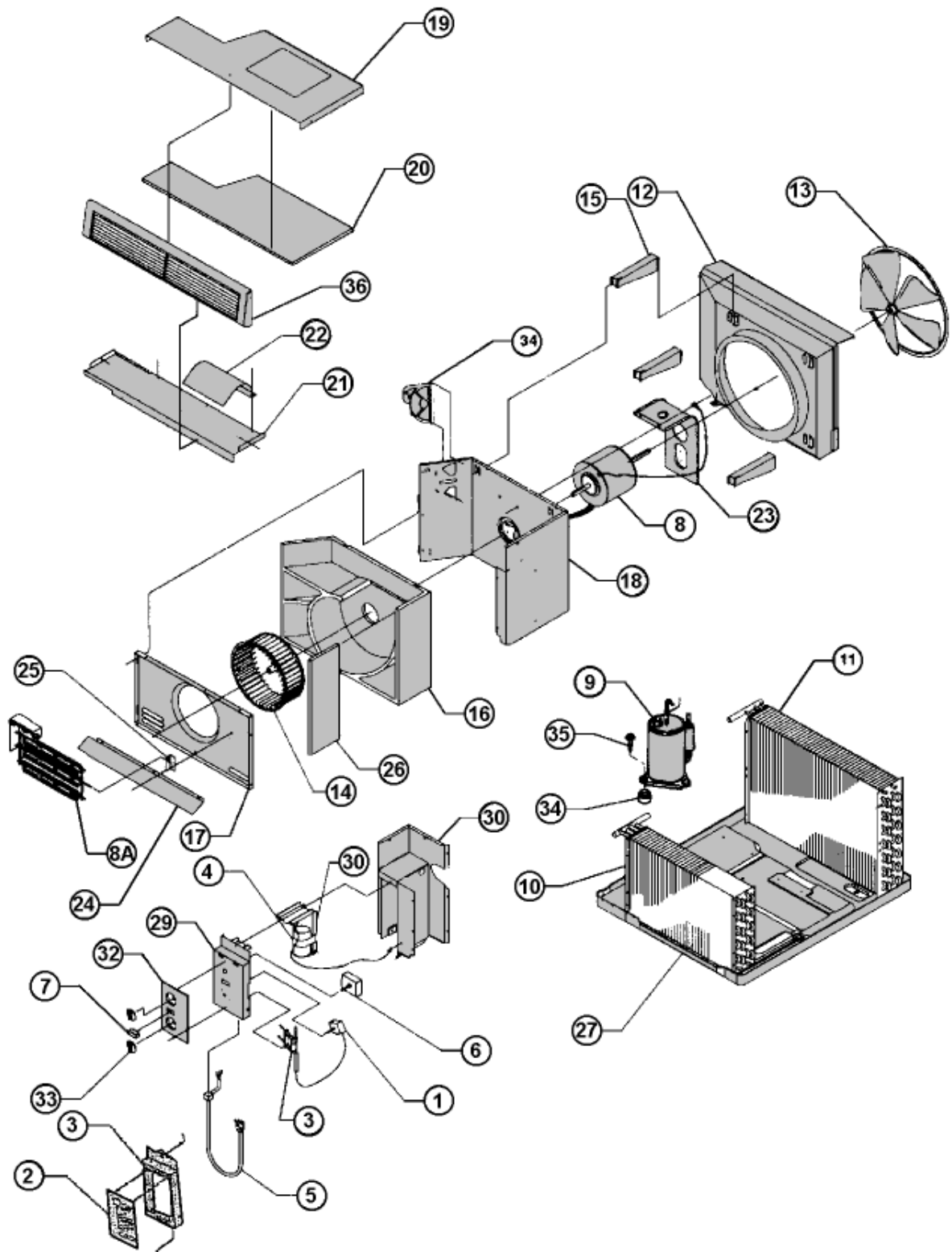

# LARGE CHASSIS "L" SERIES CABINET & MOUNTING PARTS (SL, EL, & YL)



## LARGE CHASSIS "L" SERIES PARTS LIST

REF	DESCRIPTION	PART NO#	SL 230				EL 230			CODE
			SL25J30-A	SL28J30B-A	SL36J30-A	SL36J30-B	EL25J35-A	EL36J35-A	YL24J35D-A	
<b>ELECTRICAL PARTS</b>										
1	THERMOSTAT	61828500	1		1	1				120
1	THERMOSTAT	61822400					1		1	120
1	THERMOSTAT	61822500		1						120
1	THERMOSTAT	61828400						1		120
*	THERMOSTAT, DEF.	61350313							1	122
4	CAPACITOR	61080529	1				1		1	150
4	CAPACITOR	61080557		1						150
4	CAPACITOR	61080527			1	1				150
4	CAPACITOR	61080564						1		150
5	SUPPLY CORD	60500049	1	1						220
5	SUPPLY CORD	60500055			1	1	1	1	1	220
3	RESISTOR	61808001	1	1	1	1	1	1	1	200
6	SWITCH SYS. 5 POS.	60607203	1	1	1	1				130
6	SWITCH SYS. 8 POS.	60607204					1	1	1	130
7	SWITCH (YES - NO)	61806102	1	1	1	1	1	1	1	132
8	FAN MOTOR	61871446			1	1				110
8	FAN MOTOR	61871447	1	1			1		1	110
8	FAN MOTOR	61871434						1		110
*	SOLENOID COIL	25063600							1	240
8A	HEATER	61878602					1	1	1	210
REF	DESCRIPTION	PART NO#	SL 230				EL 230			CODE
			SL25J30-A	SL28J30B-A	SL36J30-A	SL36J30-B	EL25J35-A	EL36J35-A	YL24J35D-A	
<b>REFRIGERATION PARTS</b>										
9	COMPRESSOR	61716652	1				1		1	600
9	COMPRESSOR	61716650		1						600
9	COMPRESSOR	61716632			1	1		1		600
10	EVAPORATOR COIL	62050001		1	1	1		1		400
10	EVAPORATOR COIL	61850003	1				1		1	400
11	CONDENSER COIL	62050220	1				1			410
11	CONDENSER COIL	62050209		1						410
11	CONDENSER COIL	62050201			1	1		1		410
11	CONDENSER COIL	61850203							1	410
*	DRIER, LIQUID	60308101	1	1	1	1	1	1		480
*	DRIER, SUCTION	61828201							1	480
*	CHECH VALVE	61824402							1	510
*	REVERSING VALVE	25018701							1	500
*	CAPILLARY TUBE	03760473	2				2			471
*	CAPILLARY TUBE	01390005		2	2	2		2	1	471
*	CAPILLARY TUBE	03760395							1	471

\* PARTS NOT SHOWN

## LARGE CHASSIS "L" SERIES PARTS LIST

REF	DESCRIPTION	PART NO#	SL 230				EL 230			CODE
			SL25J30-A	SL28J30B-A	SL36J30-A	SL36J30-B	EL25J35-A	EL36J35-A	YL24J35D-A	
	<b>CHASSIS PARTS</b>									
*	SHROUD, W/SUMP LRG	61807702	1	1	1	1	1	1	1	720
13	FAN BLADE, COND.	60542001								710
13	FAN BLADE, COND.	60542007	1	1	1	1	1	1	1	710
14	BLOWER WHEEL, EVAP.	60610602	1	1			1		1	700
14	BLOWER WHEEL, EVAP.	60610609			1	1		1		700
15	BRACE, COND.SHROUD	61810000	3	3	3	3	3	3	3	722
16	SCROLL	61818100	1	1	1	1	1	1	1	743
17	BLOWER FRONT	61817800	1	1	1	1	1	1	1	742
*	INSULATION, L/S AIR DECK	61818300	1	1	1	1	1	1	1	781
20	INSULATION, TOP	61818201	1	1	1	1	1	1	1	781
*	INSULATION, INNERWALL	61816902	1	1	1	1	1	1	1	781
18	INNER WALL	61907100	1	1	1	1	1	1	1	777
19	TOP COVER	61906600	1	1	1	1	1	1	1	746
21	DECK	61818000	1	1	1	1	1	1	1	745
22	AIR FOIL	61820201	1	1	1	1	1	1	1	744
24	SHIELD, BOTTOM	61813501					1		1	999
24	SHIELD, BOTTOM	61813502						1		999
26	SHIELD, SIDE	61821900					1	1	1	999
25	BRACKET, HTR	61818900					1	1	1	999
27	BASE PAN	61807101			1	1				730
27	BASE PAN	61807104	1	1						730
27	BASE PAN	61809501						1		730
27	BASE PAN	61809503					1		1	730
*	BELLOWS, DRAIN VALVE	60179903					1	1	1	801
*	DRAIN PAN, EVAP.	61807400	1	1	1	1	1	1	1	840
*	GRILLE, REAR	61818802	1	1	1	1	1	1	1	771
28	DOOR, SLIDE ASY	61821500	1	1	1	1	1	1	1	810
*	CONNECTOR SLIDE ASY	61814801	1	1	1	1	1	1	1	811
*	WIRE CLIP, SLIDE ASSY	60301800	2	2	2	2	2	2	2	999
29	PANEL, CTRL. MOUNT	61806900	1	1	1	1	1	1	1	999
*	PANEL, L/S LRG	61937000	1	1	1	1	1	1		999
31	PARTITION, CTRL. BOX	61807000	1	1	1	1				999
31	PARTITION, CTRL. BOX	61807001					1	1	1	999
30	BRACKET, CAP.MOUNT	61820400	1	1	1	1	1	1	1	999
*	STRAP, CAP.	61820702		1	1	1		1		999
*	STRAP, CAP.	61820700	1				1		1	999
32	DECORATIVE PANEL	61822600	1	1	1	1				999
32	DECORATIVE PANEL	61823300					1	1	1	999
33	KNOBS, CRTL.	61493905	2	2	2	2	2	2	2	761
*	BRACKET, RESISTOR BLK	61820600	1	1	1	1	1	1	1	999
23	MOUNT, FAN MOTOR	61806700	1	1	1	1	1	1	1	900
*	HOLDER, AIR FILTER	61823000	2	2	2	2	2	2	2	756
*	FILTER, AIR	60865810	1	1	1	1	1	1	1	754
*	CLAMP, SUPPLY CORD	91500301	1	1						999
*	CLAMP, SUPPLY CORD	91500302			1	1	1	1	1	999
34	GROMMET, COMP.	01150934	3	3	3	3	3	3	3	790
35	SCREW, COMP.	91400400	3	3	3	3	3	3	3	999
*	RETAINER, CHASSIS	61826400	1	1	1	1	1	1	1	999
*	COUNTER WEIGHT	61715800	2	2	2	2	2	2	2	999
*	GROMMET, SUCTION LN.	61807601	1	1	1	1	1	1	1	999

\* PARTS NOT SHOWN

## LARGE CHASSIS "L" SERIES PARTS LIST

REF	DESCRIPTION	PART NO#	SL 230				EL 230			CODE
			SL25J30-A	SL28J30B-A	SL36J30-A	SL36J30-B	EL25J35-A	EL36J35-A	YL24J35D-A	
<b>ELECTRICAL PARTS</b>										
36	PLENIUM ASLY.	61810500	1	1	1	1	1	1	1	753
37	GRILLE, INTAKE	61810403	1	1	1	1	1	1	1	772
*	LATCH, GRILLE INTAKE. METAL	61989000	2	2	2	2	2	2	2	772
38	OUTER SHELL	61825702	1	1	1	1	1	1	1	770
39	SILL PLATE	61808401	1	1	1	1	1	1	1	999
*	CHASSIS GUIDE, SHELL	61819601	2	2	2	2	2	2	2	999
*	CHASSIS RETAINER	61826400	1	1	1	1	1	1	1	999
*	FRIEDRICH SCRIPT	60169105	1	1	1	1	1	1	1	999
*	PUSHNUTS, SCRIPT	91002900	2	2	2	2	2	2	2	999
40	WINGBOARD	60294410	1	1	1	1				999
*	HARDWARE (SCREWS)	60846016	1	1	1	1				999
*	HARDWARE (SCREWS)	60846017					1	1	1	999
45	GASKET, CHASSIS	61717301	1	1	1	1	1	1	1	780
45	GASKET, WINDOW	60073300	1	1	1	1				780
44	GASKET, VINYL	60610303	1	1	1	1				780
*	CARTON, SHIPPING	61841903	1	1	1	1	1	1	1	999
*	PAD, SHIPPING TOP	61839601	1	1	1	1	1	1	1	999
*	PAD, FRONT SUPPORT	61839701	1	1	1	1	1	1	1	999
*	PAD, SHIPPING	61839501	1	1	1	1	1	1	1	999
*	SUPPORT, SHIPPING	61839901	2	2	2	2	2	2	2	999
*	SPACER, SHIPPING	61915100	2	2	2	2	2	2	2	999
41	BRACKET, SUPPORT	61109503	2	2	2	2				999
43	ANGLE, TOP SUPPORT	61819703	1	1	1	1				999
42	ANGLE, WINGBOARDS	61819805	2	2	2	2				999
<b>OPTIONAL ACCESSORIES</b>										
*	ACCESSORY PKGE.	WIKL					1	1	1	
*	HARD START KIT	61840900		1	1	1		1		
*	PARTS MANUAL	92013200	1	1	1	1	1	1	1	
*	SERVICE MANUAL	92013100	1	1	1	1	1	1	1	
*	INSTALLATION BOOK	92003602	1	1	1	1	1	1	1	
*	OPERATION BOOK	92000206	1	1	1	1				
*	OPERATION BOOK	92000306					1	1	1	

\* PARTS NOT SHOWN

**"C" Series  
Casement Chassis  
Room Air Conditioner Section**

# "SC" SERIES CABINET & MOUNTING PARTS



# "SC" SERIES CHASSIS PARTS



## CASEMENT CHASSIS "SC" SERIES PARTS LIST

REF	DESCRIPTION	PART NO#	CASEMENT	CODE
	ELECTRICAL PARTS		SC06H10F	
	THERMOSTAT	61350305	1	120
	OVERLOAD	61764509	1	190
	CAPACITOR	61380392	1	150
	SUPPLY CORD	60500094	1	220
	SWITCH	60895102	1	130
	FAN MOTOR	60571468	1	110
REFRIGERATION SYSTEM PARTS				
	COMPRESSOR	61716602	1	600
	EVAPORATOR COIL	61600204	1	400
	CONDENSER COIL	61600347	1	410
	CAPILLARY TUBE ASSY	61697300	1	471
	FILTER DRIER (LIQUID)	61481300	1	480
CHASSIS SYSTEM PARTS				
	SHROUD, CONDENSER	61076204	1	720
	FAN BLADE, COND.	60063411	1	710
	BLOWER WHEEL, EVAP.	60415201	1	700
	RING, ORIFICE	60232200	1	738
	WRAPPER, BLOWER	61107600	1	741
	FRONT, BLOWER	61076501	1	742
	HOUSING, BLOWER	61076801	1	740
	DECK	61077702	1	745
	PANEL ASSEMBLY, L/S	61077301	1	747
	SCREEN, BLOWER GUARD	61109001	1	774
	BRACKET, CONTROL MOUNTING	61075902	1	999
	PANEL, CONTROL (DECORATIVE)	60416203	1	760
	KNOB, CONTROL	61493903	2	761
	COVER, BULKHEAD ASSLY.	61076302	1	746
	BRACE, COND.SHROUD	61075502	1	722
	COVER, CAPACITOR	61074904	1	999
	MOUNT, MOTOR	61645402	1	900
	CLIP, MOTOR MOUNT	01060445	2	999
	COVER, CONDENSER SHROUD	61076101	1	721
	BASE PAN ASSLY.	61498705	1	730
	DRAIN PAN	60199801	1	840
	TUBE, DRAIN	60203200	1	800
	GUARD, SPLASH	61440300	1	999
	FILTER, AIR	60483801	1	754

\* PARTS NOT SHOWN

## CASEMENT CHASSIS "SC" SERIES PARTS LIST

REF	DESCRIPTION	PART NO#	CASEMENT	CODE
	CHASSIS SYSTEM PARTS		SC06H10F	
	GROMMET, COMPRESSOR	01150931	3	790
	NUT, COMPRESSOR	91002300	3	999
	WASHER, COMPRESSOR MT.	01423005	3	999
	CLIP, THERMOSTAT	61715100	1	764
	SHELL ASSEMBLY	61580900	1	770
	ANGLE, SHELL TOP SUPPORT	61427001	1	999
	SILL PLATE	61074800	1	999
	ANGLE, WINGBOARD ASSEMBLY (LIS)	61427200	1	999
	ANGLE, WINGBOARD ASSEMBLY (RIS)	61427201	1	999
	ANGLE ASSEMBLY - LEFT SIDE STUD	61427101	1	999
	ANGLE ASSEMBLY - RIGHT SIDE STUD	61427103	1	999
	GASKET, ANGLE TOP SHELL SUPPORT	60467399	1	780
	GASKET, WINGBOARDS	60467377	2	780
	BRACKETS, SUPPORT	61109503	2	999
*	SCRIPT, FRIEDRICH	60169101	1	999
*	NUT, FRIEDRICH SCRIPT	91002900	2	999
	GASKET, CHASSIS	60073301	1	780
	FRONT, DECORATIVE	61077501	1	750
*	HARDWARE KIT	60714305	1	999
	SHIPPING CARTON	61630610	1	999
	PAD, SHIPPING TOP	61630802	1	999
	PAD, SHIPPING TOP	61632000	1	999
	PAD, SHIPPING VERTICAL	61631900	1	999
	PAD, SHIPPING VERTICAL	61631901	1	999
OPTIONAL ACCESSORY ITEMS				
	KIT, INSTALLATION (DOUBLE HUNG WINDOW)	01900241	1	
	ANTI-ICE KIT	60553104	1	
	START KIT	61003803	1	
	INSTALLATION BOOK	92003500	1	
	OPERATION BOOK	92000604	1	
	PARTS MANUAL	92013200	1	
	SERVICE MANUAL	92013100	1	

\* PARTS NOT SHOWN



**Use Factory-Certified Parts.**

**Friedrich®**

**FRIEDRICH AIR CONDITIONING CO.**

Post Office Box 1540 · San Antonio, Texas 78295-1540  
4200 N. Pan Am Expressway · San Antonio, Texas 78218-5212  
(210) 357-4400 · FAX (210) 357-4480

[www.friedrich.com](http://www.friedrich.com)

Printed in the U.S.A.

920-132-00 (4-04)