

This Owner's Manual is provided and hosted by [Appliance Factory Parts](#).

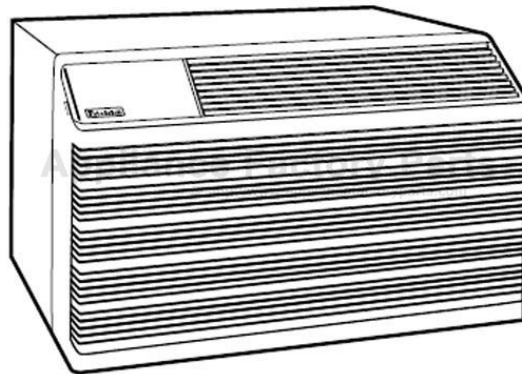

# FRIEDRICH WS12A10E Owner's Manual

[Shop genuine replacement parts for FRIEDRICH  
WS12A10E](#)



[Find Your FRIEDRICH Air Conditioner Parts - Select From 1575 Models](#)

----- Manual continues below -----

**Friedrich**<sup>®</sup>

# Service & Parts Manual

## WallMaster<sup>®</sup> Thru-the-Wall 2003

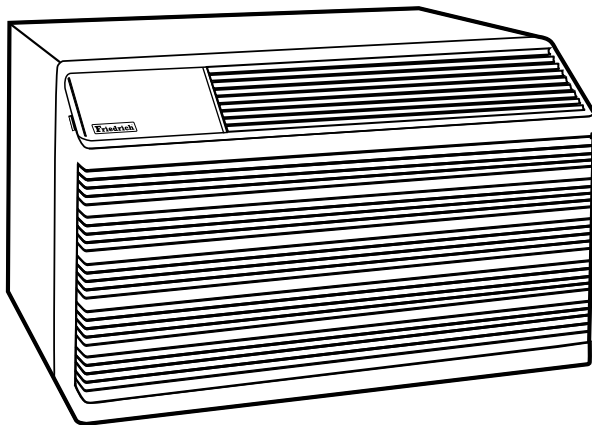

WS07A10B  
WS10A10B  
WS12A10E-B  
WS12A10E-C  
WS12A30E-B  
WS15A30B  
WE09A33E-C  
WE12A33E-B  
WE15A33B  
WY09A33F-A  
WY12A33G-A

# TABLE OF CONTENTS

PAGE

## GENERAL

Friedrich WallMaster Model Code .....	4
Application and Sizing .....	4
Instructions For Using Cooling Load Estimate Form .....	5
Cooling Load Estimate Form .....	6
Heat Load Form .....	7
Heating Load From Friedrich Unit Heat Pumps .....	8

## SPECIFICATIONS/PERFORMANCE DATA

Specifications "WS" Models .....	9
Performance Data "WS" Models .....	9
Specifications "WE" and "WY" Models .....	10
Performance Data Heating "WE" Models .....	11
Performance Data Heating "WY" Models .....	12

## COMPONENTS OPERATION/TESTING

Compressors .....	13
Thermal Overload (External) .....	13
Thermal Overload (Internal) .....	14
Fan Motor .....	14
System Control Switch ("WS" Models) .....	15
System Control Switch ("WE" & "WY" Models) .....	15
Run, Capacitor .....	16
Thermostat ("WS" Models) .....	17
Thermostat ("WE" & "WY" Models) .....	17
Thermostat Adjustment .....	18
Heating Element ("WE" & "WY" Models) .....	18
Defrost Control ("WY" Models Only) .....	18
Defrost Bulb Location (All "WY" Models) .....	19
Solenoid Coil ("WY" Models Only) .....	19
Check Valve .....	19
Drain Pan Valve .....	20
Reversing Valve ("WY" Models Only) .....	20
Sealed Refrigeration System Repairs .....	21
Hermetic Component Replacement .....	21
Special Procedure in the case of Motor Compressor Burn-Out .....	22
Rotary Compressor Special Troubleshooting & Service .....	22
Refrigerant Charge .....	22

# TABLE OF CONTENTS (Cont.)

	<b>PAGE</b>
<b>TROUBLESHOOTING</b>	
Troubleshooting Touch Test Chart .....	23
Troubleshooting (Cooling) .....	24
Troubleshooting (Heating) .....	28
Troubleshooting (Cooling/Electric) .....	30
<b>WIRING DIAGRAMS</b>	
WS07A10E-D .....	34
WS09A10 .....	34
WS12A10 .....	34
WS09A30 .....	34
WS12A30 .....	34
WS13A30 .....	34
WE09A33 .....	35
WE12A33 .....	35
WE13A33 .....	35
WY09A33 .....	36
WY12A33 .....	36
<b>PARTS LIST</b>	
"WS" Series Parts List .....	38
"WE" & "WY" Series Parts List .....	44
WallMaster Sleeve Parts List .....	47

## FRIEDRICH ROOM MODEL NUMBER CODE

**W S 07 A 1 0 B**

1st DIGIT - FUNCTION \_\_\_\_\_

W = Thru-The-Wall, WallMaster Series

2nd DIGIT - TYPE \_\_\_\_\_

S = Straight Cool

E = Electric Heat

Y = Heat Pump

3rd & 4th DIGITS - APPROXIMATE BTU/HR (Cooling) \_\_\_\_\_

Heating BTU/HR capacity listed in Specifications/Performance Data Section

5th DIGIT - ALPHABETICAL MODIFIER \_\_\_\_\_

6th DIGIT - VOLTAGE \_\_\_\_\_

1 = 115 Volts

2 = 230 Volts

3 = 230-208 Volts

7th DIGIT \_\_\_\_\_

0 = Straight Cool & Heat Pump Models

**ELECTRIC HEAT MODELS**

1 = 1 KW Heat Strip, Nominal

3 = 3 KW Heat Strip, Nominal

4 = 4 KW Heat Strip, Nominal

5 = 5 KW Heat Strip, Nominal

8 = 8 KW Heat Strip, Nominal

8th DIGIT \_\_\_\_\_

Major Change

---

## APPLICATION AND SIZING

In the application and sizing of room air conditioners for cooling, it is most important to give full consideration to all factors which may contribute to the heat loss or gain of the space to be conditioned. It is therefore necessary to make a survey of the space to be conditioned and calculate the load requirements before a selection of the size of the equipment needed can be made.

The load requirement may be determined very easily by simply using the standard "AHAM" Load Calculating Form, on Page 6. This form is very easy to use and is self explanatory. It is necessary only to insert the proper measurements on the lines provided and multiply by the given factors, then add the result for the total load requirements.

Cooling load requirements are generally based on the cooling load for comfortable air conditioning which does not require specific conditions of inside temperature and humidity. The load calculation form is based on outside design temperature of 95° FDB and 75° FWB. It can be used for areas in the Continental United States having other outside design temperatures by applying a correction factor for the particular locality as determined from the map shown on Page 6.

When sizing a TwinTemp unit for cooling and heating, we must remember that the heating capacity of any given unit varies directly with the outdoor ambient temperature. Also, we must keep in mind the average low temperatures which might be experienced in the locality where the unit is to be installed. Therefore, when sizing a TwinTemp unit, both cooling and heating requirements must be calculated. Do not oversize, or undersize, one phase of the unit's capacity at the expense of the other. In those cases where the unit will provide satisfactory cooling at all times but will be inadequate for those few times that the outdoor temperature is below the maximum low for the unit, additional auxiliary heating facilities must be provided to insure that adequate heat is available at all times.

**INSTRUCTIONS FOR USING COOLING LOAD ESTIMATE  
FORM FOR ROOM AIR CONDITIONERS  
(AHAM PUB. NO. RAC-1)**

- A. This cooling load estimate form is suitable for estimating the cooling load for comfort air conditioning installations which do not require specific conditions of inside temperature and humidity.
- B. The form is based on an outside design temperature of 95°F dry bulb and 75°F wet bulb. It can be used for areas in the continental United States having other outside design temperatures by applying a correction factor for the particular locality as determined from the map.
- C. The form includes "day" factors for calculating cooling loads in rooms where daytime comfort is desired (such as living rooms, offices, etc.)
- D. The numbers of the following paragraphs refer to the corresponding numbered item on the form:
1. Multiply the square feet of window area for each exposure by the applicable factor. The window area is the area of the wall opening in which the window is installed. For windows shaded by inside shades or venetian blinds, use the factor for "Inside Shades." For windows shaded by outside awnings or by both outside awnings and inside shades (or venetian blinds), use the factor for "Outside Awnings." "Single Glass" includes all types of single thickness windows, and "Double Glass" includes sealed airspace types, storm windows, and glass block. Only one number should be entered in the right hand column for Item 1, and this number should represent **only the exposure with the largest load.**
  2. Multiply the total square feet of **all** windows in the room by the applicable factor.
  - 3a. Multiply the total length (linear feet) of all walls exposed to the outside by the applicable factor. Doors should be considered as being part of the wall. Outside walls facing due north should be calculated separately from outside walls facing other directions. Walls which are permanently shaded by adjacent structures should be considered "North Exposure." Do not consider trees and shrubbery as providing permanent shading. An uninsulated frame wall or a masonry wall 8 inches or less in thickness is considered "Light Construction." An insulated wall or masonry wall over 8 inches in thickness is considered "Heavy Construction."
  - 3b. Multiply the total length (linear feet) of all inside walls between the space to be conditioned and any unconditioned spaces by the given factor. Do not include inside walls which separate other air conditioned rooms.
  4. Multiply the total square feet of roof or ceiling area by the factor given for the type of construction most nearly describing the particular application (use one line only.)
  5. Multiply the total square feet of floor area by the factor given. Disregard this item if the floor is directly on the ground or over a basement.
  6. Multiply the number of people who normally occupy the space to be air conditioned by the factor given. Use a minimum of 2 people.
  7. Determine the total number of watts for light and electrical equipment, except the air conditioner itself, that will be **in use** when the room air conditioning is operating. Multiply the total wattage by the factor given.
  8. Multiply the total width (linear feet) of any doors or arches which are continually open to an unconditioned space by the applicable factor.  
**NOTE:** Where the width of the doors or arches is more than 5 feet, the actual load may exceed the calculated value. In such cases, both adjoining rooms should be considered as a single large room, and the room air conditioner unit or units should be selected according to a calculation made on this new basis.
  9. Total the loads estimated for the foregoing 8 items.
  10. Multiply the subtotal obtained in item 9 by the proper correction factor, selected from the map, for the particular locality. The result is the total estimated design cooling load in BTU per hour.
- E. For best results, a room air conditioner unit or units having a cooling capacity rating (determined in accordance with the NEMA Standards Publication for Room Air Conditioners, CN 1-1960) as close as possible to the estimated load should be selected. In general, a greatly oversized unit which would operate intermittently will be much less satisfactory than one which is slightly undersized and which would operate more nearly continuously.
- F. Intermittent loads such as kitchen and laundry equipment are not included in this form.

## COOLING LOAD ESTIMATE FORM

HEAT GAIN FROM	QUANTITY	FACTORS			BTU/Hr.
		DAY			(Quantity x Factor)
		No Shades*	Inside Shades*	Outside Awnings*	(Area X Factor)
<b>1. WINDOWS:</b> Heat gain from the sun.					
Northeast	___ sq. ft.	60	25	20	Use ___
East	___ sq. ft.	80	40	25	only ___
Southeast	___ sq. ft.	75	30	20	the ___
South	___ sq. ft.	75	35	20	largest ___
Southwest	___ sq. ft.	110	45	30	load. ___
West	___ sq. ft.	150	65	45	Use ___
Northwest	___ sq. ft.	120	50	35	only ___
North	___ sq. ft.	0	0	0	one. ___
<b>2. WINDOWS: Heat by conduction</b> (Total of all windows.)					
Single glass	___ sq. ft.		14		___
Double glass or glass block	___ sq. ft.		7		___
<b>3. WALLS:</b> (Based on linear feet of wall)					
		Light Construction		Heavy Construction	
a. Outside walls					
North Exposure	___ ft.	30		20	___
Other than North exposure	___ ft.	60		30	___
b. Inside Walls (between conditioned and unconditioned spaces only.)	___ sq. ft.		30		___
<b>4. ROOF OR CEILING:</b> (Use one only)					
a. Roof, uninsulated	___ sq. ft.		19		___
b. Roof, 1 inch or more insulation	___ sq. ft.		8		___
c. Ceiling, occupied space above	___ sq. ft.		3		___
d. Ceiling, insulated, with attic space above	___ sq. ft.		5		___
e. Ceiling, uninsulated, with attic space above	___ sq. ft.		12		___
<b>5. Floor:</b> (Disregard if floor is directly on ground or over a basement.)	___ sq. ft.		3		___
<b>6. NUMBER OF PEOPLE</b>	___		600		___
<b>7. LIGHTS AND ELECTRICAL EQUIPMENT IN USE</b>	___ watts		3		___
<b>8. DOORS AND ARCHES CONTINUOUSLY OPENED TO UNCONDITIONED SPACE:</b> (TOTAL LINEAR FEET OF WIDTH.)	___ ft.		300		___
<b>9. SUBTOTAL</b>	*****		*****		___
<b>10. TOTAL COOLING LOAD</b> (BTU per hour to be used for selection of room air conditioner(s).)	___ Total in Item 9 X ___ (Factor from Map) = ___				

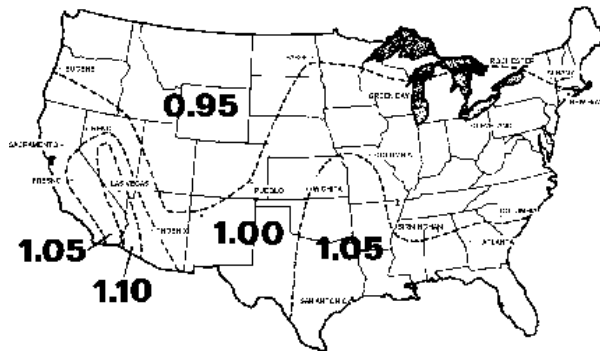

## HEAT LOAD FORM

The heat load form, Page 8, may be used by servicing personnel to determine the heat loss of a conditioned space and the ambient winter design temperatures in which the unit will heat the calculated space.

The upper half of the form is for computing the heat loss of the space to be conditioned. It is necessary only to insert the proper measurements on the lines provided and multiply by the given factors, then add this result for the total heat loss in BTU/Hr./°F.

The BTU/Hr. per °F temperature difference is the 70°F inside winter designed temperature minus the lowest outdoor ambient winter temperature of the area where the unit is installed. This temperature difference is used as the multiplier when calculating the heat loss.

The graph shows the following:

Left Hand Scale	Unit capacity BTU/Hr. or heat loss BTU/Hr.
Bottom Scale	Outdoor ambient temperature, base point.
Heat Pump Model	BTU/Hr. capacity heat pump will deliver at outdoor temperatures.
Balance Point	Maximum BTU/Hr. heat pump will deliver at indicated ambient temperature.

Below is an example using the heat load form:

A space to be conditioned is part of a house geographically located in an area where the lowest outdoor ambient winter temperature is 40°F. The calculated heat loss is 184 BTU/Hr./°F.

Subtract 40°F (lowest outdoor ambient temperature for the geographical location) from 70°F (inside design temperature of the unit) for a difference of 30°F. Multiply 184 by 30 for a 5500 BTU/Hr. total heat loss for the calculated space.

On the graph, plot the base point (70°) and a point on the 40°F line where it intersects with the 5500 BTU/Hr. line on the left scale. Draw a straight line from the base point 70 through the point plotted at 40°F. This is the total heat loss line.

Knowing that we have a 5500 BTU/Hr. heat loss, and we expect that our heat pump will maintain a 70°F inside temperature at 40°F outdoor ambient, we plot the selected unit capacity BTU/Hr. of the unit between 35° and 60° on the graph and draw a straight line between these points. Where the total heat loss line and the unit capacity line intersect, read down to the outdoor ambient temperature scale and find that this unit will deliver the required BTU/Hr. capacity to approximately 30°F.

# HEATING LOAD FORM

## FRIEDRICH ROOM UNIT HEAT PUMPS

	BTU/HR PER °F TEMP. DIFFERENCE
<b>WALLS:</b> (Linear Feet)	
2" Insulation	Lin. Ft. x 1.6
Average	Lin. Ft. x 2.6
<b>WINDOWS &amp; DOORS</b> (Area, sq. ft.)	
Single Glass:	Sq. Ft. x 1.13
Double Glass:	Sq. Ft. x 0.61
<b>INFILTRATION - WINDOWS &amp; DOORS: AVG.</b>	Lin. Ft. x 1.0
Loose	Lin. Ft. x 2.0
<b>CEILING:</b> (Area, Sq. Ft.)	
Insulated (6")	Sq. Ft. x 0.07
Insulated (2")	Sq. Ft. x 0.10
Built-up Roof (2" insulated)	Sq. Ft. x 0.10
Built-up Roof (1/2" insulated)	Sq. Ft. x 0.20
No Insulation	Sq. Ft. x 0.33
<b>FLOOR:</b> (Area, Sq. Ft.)	
Above Vented Crawl space	
Insulated (1:)	Sq. Ft. x 0.20
Uninsulated	Sq. Ft. x 0.50
* Slab on Ground	Lin. Ft. x 1.70
1" Perimeter insulation	Lin. Ft. x 1.00

\* Based on Linear Feet of outside wall TOTAL HEAT LOSS PER °F BTU/HR/°F

Multiply total BTU/HR/°F X 30 and plot on the graph below at 40°F. Draw a straight line from the 70 base point thru the point plotted at 40°F. The intersection of this heat loss line with the unit capacity line represents the winter design heating load.

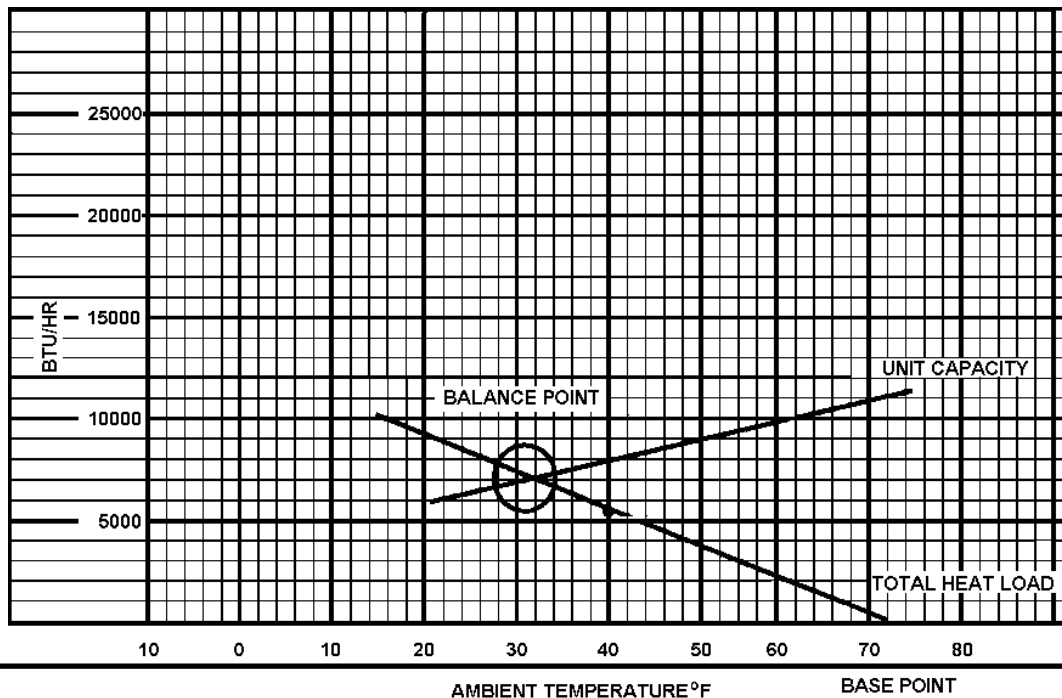

<b>SPECIFICATIONS</b>	<b>WS07A10D</b>	<b>WS10A10B</b>	<b>WS12A10E-B</b>	<b>WS12A30EB</b>	<b>WS15A30B</b>
<b>BTUH</b>	<b>7400</b>	<b>10000</b>	<b>11500</b>	<b>12000</b> <b>11800</b>	<b>14700</b> <b>14500</b>
<b>E.E.R.</b>	<b>9.5</b>	<b>9.2</b>	<b>9.2</b>	<b>9.0</b> <b>9.0</b>	<b>8.7</b> <b>8.5</b>
<b>Volts</b>	<b>115</b>	<b>115</b>	<b>115</b>	<b>230</b> <b>208</b>	<b>230</b> <b>208</b>
<b>Amperes</b>	<b>7.0</b>	<b>9.8</b>	<b>11.5</b>	<b>6.0</b> <b>6.5</b>	<b>7.7</b> <b>8.5</b>
<b>Total Watts</b>	<b>773</b>	<b>1081</b>	<b>1280</b>	<b>1333</b> <b>1310</b>	<b>1693</b> <b>1686</b>
<b>Hertz</b>	<b>60</b>	<b>60</b>	<b>60</b>	<b>60</b>	<b>60</b>
<b>Fuse/Breaker Size</b>	<b>15</b>	<b>15</b>	<b>15</b>	<b>15</b>	<b>15</b>
<b>Fan RPM</b>	<b>1145</b>	<b>1140</b>	<b>1275</b>	<b>1275</b>	<b>1275</b>
<b>Evaporator Air CFM</b>	<b>260</b>	<b>260</b>	<b>290</b>	<b>290</b>	<b>250</b>
<b>Fresh Air CFM</b>					
<b>Exhaust Air</b>	<b>Yes</b>	<b>Yes</b>	<b>Yes</b>	<b>Yes</b>	<b>Yes</b>
<b>Dehumidification Pts/Hr</b>	<b>1.4</b>	<b>2.1</b>	<b>2.9</b>	<b>2.9</b>	<b>4.0</b>
<b>Width</b>	<b>27"</b>	<b>27"</b>	<b>27"</b>	<b>27"</b>	<b>27"</b>
<b>Height</b>	<b>16-3/4"</b>	<b>16-3/4"</b>	<b>16-3/4"</b>	<b>16-3/4"</b>	<b>16-3/4"</b>
<b>Depth</b>	<b>16-3/4"</b>	<b>16-3/4"</b>	<b>16-3/4"</b>	<b>16-3/4"</b>	<b>16-3/4"</b>
<b>Minimum Ext. Into Room</b>	<b>7-1/2"</b>	<b>7-1/2"</b>	<b>7-1/2"</b>	<b>7-1/2"</b>	<b>7-1/2"</b>
<b>Minimum Ext. To Outside</b>	<b>9/16"</b>	<b>9/16"</b>	<b>9/16"</b>	<b>9/16"</b>	<b>9/16"</b>
<b>Net Weight</b>	<b>75</b>	<b>85</b>	<b>94</b>	<b>91</b>	<b>101</b>
<b>Shipping Weight</b>	<b>93</b>	<b>103</b>	<b>112</b>	<b>109</b>	<b>119</b>

<b>PERFORMANCE DATA*</b> <b>Cooling</b>	<b>EVAPORATOR AIR TEMP. °F.</b>		<b>OPERATING PRESSURES</b>		<b>ELECTRICAL RATINGS</b>		<b>R-22 REFRIG.</b>	<b>COMP. OIL</b>
	<b>DISCHARGE AIR</b>	<b>TEMP. DROP °F.</b>	<b>SUCTION</b>	<b>DISCHARGE</b>	<b>AMPS</b>	<b>LOCKED ROTOR AMPS</b>	<b>CHARGE IN OUNCES</b>	<b>CHARGE IN FLUID OZ.</b>
<b>WS07A10D</b>	59.5	19.5	82	280	7.0	32.0	19	11.8
<b>WS09A10D</b>	58.0	22.0	82	295	9.8	44.0	20	11.8
<b>WS12A10D</b>	55.0	25.0	76	295	11.5	54.0	36	11.8
<b>WS12A30D</b>	55.0	25.0	76	295	6.0 6.5	26.3	36	11.8
<b>WS13A30D</b>	47.1	32.9	73	308	7.7 8.5	33.0	38	11.8

\*Rating Conditions: 80°F. Room Air Temperature and 50% Relative Humidity with 95°F. Outside Air Temperature at 40% Relative Humidity.

<b>SPECIFICATIONS</b>	<b>WE07A33EC</b>	<b>WE12A33EB</b>	<b>WE15A33B</b>	<b>WY09A33FA</b>	<b>WY12A33GA</b>
BTUH (Cooling)	9000 8900	12000 11800	14700 14500	9000 8900	11500 11000
BTUH (Heating)	7000 7000	11000 9100	11000 9100	7000 7000	10500 10300
E.E.R. (Cooling)	8.7	9.0 9.0	8.7 8.6	8.6 9.3	9.0 9.0
E.E.R (Heating)	8.7			8.7 8.7	9.0 9.0
Volts	230 208	230 208	230 208	230 208	230 208
Amperes (Cooling)	4.3 4.6	6.0 6.5	7.7 8.5	3.6 4.0	5.8 6.2
Amperes (Heating)	16.0 14.7	16.0 14.7	16.93 16.86	16.7 14.7	16.0 14.7
Total Watts (Cooling)	973 947	1333 1310	1693 1686	973 947	1307 1273
Total Watts (Heating)	805 805	3550 2950	3550 2950	805 805	1167 1144
Hertz	60	60	60	60	60
Fuse/Breaker Size	20	20	20	20	20
Fan RPM	1140	1275	1275	1140	1275
Evaporator Air CFM	260	290	250	270	290
Fresh Air CFM					
Exhaust Air CFM	Yes	Yes	Yes	Yes	Yes
Dehumidification Pts/Hr	2.1	2.9	4.0	2.1	2.9
Width	27"	27"	27"	27"	27"
Height	16 3/4"	16 3/4"	16 3/4"	16 3/4"	16 3/4"
Depth	16 3/4"	16 3/4"	16 3/4"	16 3/4"	16 3/4"
Minimum Ext. Into Room	7 1/2"	7 1/2"	7 1/2"	7 1/2"	7 1/2"
Minimum Ext. To Outside	9/16"	9/16"	9/16"	9/16"	9/16"
Net Weight	84	92	102	86	94
Shipping Weight	103	111	121	107	116

<b>PERFORMANCE DATA*</b>	<b>EVAPORATOR AIR TEMP. °F.</b>		<b>OPERATING PRESSURES</b>		<b>ELECTRICAL RATINGS</b>		<b>R-22 REFRIG.</b>	<b>COMP. OIL</b>
	<b>DISCHARGE AIR</b>	<b>TEMP. DROP °F.</b>	<b>SUCTION</b>	<b>DISCHARGE</b>	<b>AMPS</b>	<b>LOCKED ROTOR AMPS</b>	<b>CHARGE IN OUNCES</b>	<b>CHARGE IN FLUID OZ.</b>
Cooling								
WE09A33EC	58.0	22.0	80	295	4.3 4.6	20.0	20	11.8
WE12A33EB	55.0	25.0	76	295	6.0 6.5	26.3	36	11.8
WE15A33B	47.1	32.9	73	308	7.7 8.5	33.0	38	11.8
WY09A33FA	58.0	22.0	80	295	3.6 5.8	20.0	26	11.8
WY12A33GA	55.0	25.0	76	295	5.8 6.2	26.3	43	11.8

\*Rating Conditions: 80°F. Room Air Temperature and 50% Relative Humidity with 95°F. Outside Air Temperature at 40% Relative Humidity.

<b>PERFORMANCE DATA (Heating)</b>	<b>VOLTS</b>	<b>BTUH</b>	<b>CFM HIGH SPEED</b>	<b>HEAT RISE</b>
WE09A33EC	230 208	11000 9100	260	39.0
WE12A33E-B	230 208	11000 9100	290	35.0
WE15A33GA	230 208	11000 9100	250	40.0

<b>PERFORMANCE DATA (Heating)</b>		<b>*WY09A33FA</b>	<b>*WY12A33GA</b>
<b>BTUH</b>	@70°F Inside 62°F Outside	9700	12400
	@70°F Inside 57°F Outside	9300	12000
	@70°F Inside 52°F Outside	8800	11400
	** @70°F Inside 47°F Outside	8200/8100	10800/10400
	@70°F Inside 42°F Outside	7600	10000
	@70°F Inside 37°F Outside	6800	9000
	@70°F Inside 35°F Outside	11000/9100	11000/9100
	<b>Evaporator Air Temperature Rise</b>		
	@70°F Inside 62°F Outside	32.00	37.60
	@70°F Inside 57°F Outside	30.75	36.40
	@70°F Inside 52°F Outside	29.10	34.50
	** @70°F Inside 47°F Outside	27.10/26.80	32.70/31.50
	@70°F Inside 42°F Outside	25.10	30.30
	@70°F Inside 37°F Outside	22.50	27.30
	@70°F Inside 35°F Outside	36.40/30.10	33.30/27.60
	<b>AMPS</b>	@70°F Inside 62°F Outside	4.0
@70°F Inside 57°F Outside		3.9	5.5
@70°F Inside 52°F Outside		3.85	5.4
** @70°F Inside 47°F Outside		3.8/4.1	5.3/5.6
@70°F Inside 42°F Outside		3.6	5.1
@70°F Inside 37°F Outside		3.4	4.8
@70°F Inside 35°F Outside		16.0/14.7	16.0/14.7
<b>Watts</b>		@70°F Inside 62°F Outside	880
	@70°F Inside 57°F Outside	870	1260
	@70°F Inside 52°F Outside	860	1220
	** @70°F Inside 47°F Outside	835/810	1175/1155
	@70°F Inside 42°F Outside	800	1130
	@70°F Inside 37°F Outside	760	1070
	@70°F Inside 35°F Outside	3550/2950	3550/2950
	<b>Suction/Head PSIG</b>		
	@70°F Inside 62°F Outside	66/315	61/325
	@70°F Inside 57°F Outside	62/285	59/290
	@70°F Inside 52°F Outside	57/285	53/275
	** @70°F Inside 47°F Outside	53/265	49/255
	@70°F Inside 42°F Outside	49/215	45/240
	@70°F Inside 37°F Outside	45/203	41/220
	@70°F Inside 35°F Outside	44/200	40/215

\* Heating Element comes on at 35°F outside ambient and compressor shuts off.

\*\* AHAM Rating Conditions.

## COMPONENTS OPERATION & TESTING

### WARNING

DISCONNECT ELECTRICAL POWER TO UNIT BEFORE SERVICING OR TESTING

## COMPRESSORS

Compressors are single phase, 115 or 230/208 volt, depending on the model unit. All compressor motors are permanent split capacitor type using only a running capacitor across the start and run terminal.

All compressors are internally spring mounted and externally mounted on rubber isolators.

### COMPRESSOR WINDING TEST

Remove compressor terminal box cover and disconnect wires from terminals. Using an ohmmeter, check continuity across the following:  
(See Figure 1)

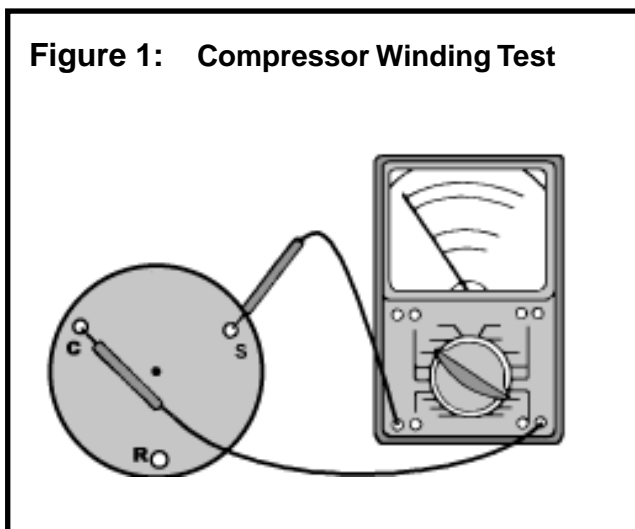

1. Terminal "C" and "S" - no continuity - open winding - replace compressor.
2. Terminal "C" and "R" - no continuity - open winding - replace compressor.
3. Terminal "R" and "S" - no continuity - open winding - replace compressor.

## GROUND TEST

Use an ohmmeter set on its highest scale. Touch one lead to the compressor body (clean point of contact as a good connection is a must) and the other probe in turn to each compressor terminal (see Figure 2.) If a reading is obtained, the compressor is grounded and must be replaced.

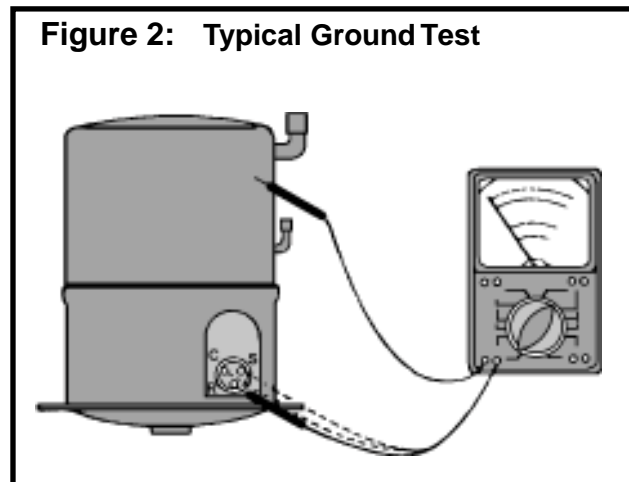

## CHECKING COMPRESSOR EFFICIENCY

The reason for compressor inefficiency is normally due to broken or damaged suction and/or discharge valves, reducing the ability of the compressor to pump refrigerant gas.

This condition can be checked as follows:

1. Install a piercing valve on the suction and discharge or liquid process tube.
2. Attach gauges to the high and low sides of the system.
3. Start the system and run a "cooling or heating performance test."

If test shows:

- A. **Below** normal high side pressure.
- B. **Above** normal low side pressure.
- C. **Low** temperature difference across coil.

The compressor valves are faulty - replace the compressor.

## THERMAL OVERLOAD (External)

Some compressors are equipped with an external overload which is located in the compressor terminal box adjacent to the compressor body (see Figure 3.)

The overload is wired in series with the common motor terminal. The overload senses both major amperage and compressor temperature. High motor temperature or amperage heats the disc causing it to open and break the circuit to the common motor terminal.

**Figure 3: External Overload**

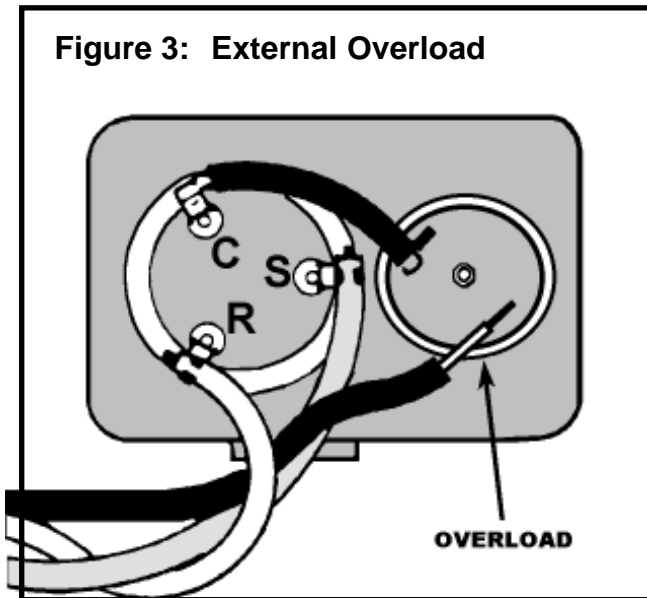

Heat generated within the compressor shell is usually due to:

1. High amperage.
2. Low refrigerant charge.
3. Frequent recycling.
4. Dirty condenser.

**TERMINAL OVERLOAD - TEST**  
(Compressor - External Type)

1. Remove overload.
2. Allow time for overload to reset before attempting to test.
3. Apply ohmmeter probes to terminals on overload wires. There should be continuity through the overload.

**TERMINAL OVERLOAD (Internal)**

Some model compressors are equipped with an internal overload. The overload is embedded in the motor windings to sense the winding temperature and/or current draw. The overload is connected in series with the common motor terminal.

Should the internal temperature and/or current draw become excessive, the contacts in the overload will open, turning off the compressor. The overload will automatically reset, but may require several hours before the heat is dissipated.

CHECKING THE INTERNAL OVERLOAD (see Figure 4.)

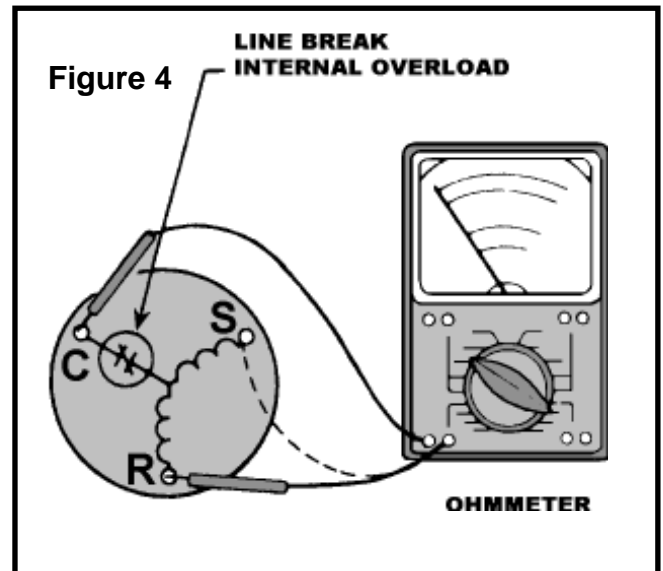

1. With no power to unit, remove the leads from the compressor terminals.
2. Using an ohmmeter, test continuity between terminals C-S and C-R. If not continuous, the compressor overload is open and the compressor must be replaced.

**FAN MOTOR**

A single phase permanent split capacitor motor is used to drive the evaporator blower and condenser fan. A self-resetting overload is located inside the motor to protect against high temperature and high amperage conditions.

Although fan motors are lubricated at the factory and sealed, oil ports are provided to lubricate to motor annually after the first year of operation (see Figure 5.) To lubricate (oil), remove the oil plugs on each end of the fan motor and put up to 30 drops of SAE10W30 grade motor oil in each hole, then replace oil plugs.

**Figure 5: Fan Motor**

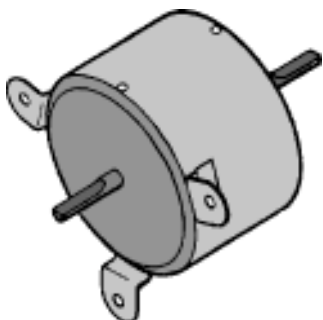

**FAN MOTOR - TEST**

1. Determine that capacitor is serviceable.
2. Disconnect fan motor wires from fan speed switch or system switch.
3. Apply "live" test cord probes on black wire and common terminal of capacitor. Motor should run at high speed.
4. Apply "live" test cord probes on red wire and common terminal of capacitor. Motor should run at low speed.
5. Apply "live" test cord probes on each of the remaining wires from the speed switch or system switch to test intermediate speeds.

**SYSTEM CONTROL SWITCH ("WS" Models)**

A five position control switch is used to regulate the operation of the fan motor and compressor. The compressor can be operated with the fan operating at low, medium or high speed. The fan motor can also be operated independently on medium speed. See switch section as indicated on decorative control panel (see Figure 7.)

**SYSTEM CONTROL SWITCH - TEST**

Disconnect leads from control switch (see Figure 8.) There must be continuity as follows:

**Figure 6: System Control Panel**

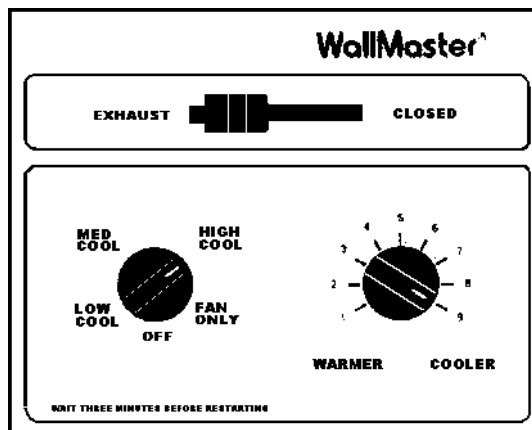

1. "Off" Position - no continuity between terminals.
2. "Lo Cool" Position - between terminals "L1" and "C", "LO" and "MS".
3. "Med Cool" Position - between terminals "L1" and "C", "M" and "MS".
4. "Hi Cool" Position - between terminals "L1" and "C", "H" and "MS".
5. "Fan Only" Position - between terminals "L1" and

**Figure 7: System Control Switch**

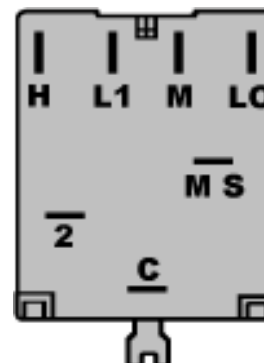

**SYSTEM CONTROL SWITCH ("WE" & "WY" Models)**

An eight position switch is used to regulate the operation of the fan motor, compressor and electric heater.

The unit can be operated in cooling or heating mode with the compressor or electric heater on and the fan motor operating on low, medium or high speed.

The fan motor can also be operated independently on medium speed. See switch section as indicated on decorative control panel, in Figure 8.

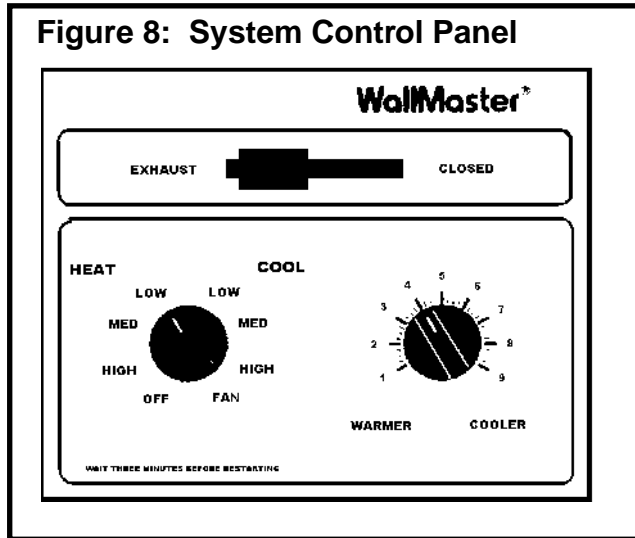

**Figure 8: System Control Panel**

### SYSTEM CONTROL SWITCH - TEST

Disconnect leads from control switch. Turn control to position being tested (see Figure 8.) There must be continuity as follows:

1. "Off" Position-no continuity between terminals.
2. "Lo Cool" Position-between terminals "C" and "3", "C2" and "2", "LO" and "M/S", "AR" and "5".
3. "Med Cool" Position-between terminals "C" and "3", "C2" and "2", "M" and "M/S", "AR" and "5".
4. "Hi Cool" Position-between terminals "C" and "3", "C2" and "2", "H" and "M/S", "AR" and "5".
5. "Hi Heat" Position-between terminals "C" and "1", "C2" and "4", "H" and "M/S", "AR" and "5".
6. "Med Heat" Position-between terminals "C" and "1", "C2" and "4", "M" and "M/S", "AR" and "5".
7. "Lo Cool" Position-between terminals "C" and "1", "C2" and "4", "LO" and "M/S", "AR" and "5".
8. "Fan Only" Position-between terminals "L1" and "M".

**Figure 9: System Control Switch (Heat Pump & Electric Heat Models)**

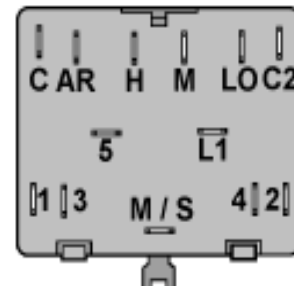

"2".  
NOTE:  
Units will operate in constant fan in the cooling mode and auto fan in the heating mode.

### CAPACITOR, RUN

A run capacitor is wired across the auxiliary and main winding of a single phase permanent split capacitor motor such as the compressor and fan motor. A single capacitor can be used for each motor or a dual rated capacitor can be used for both.

**Figure 10: Run Capacitor Hook-Up**

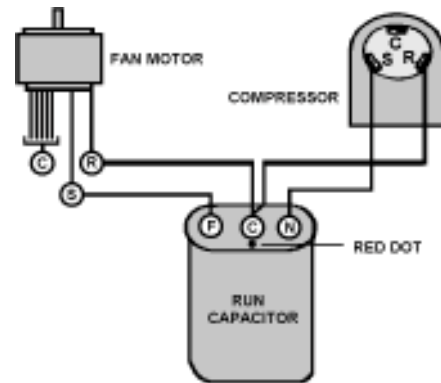

The capacitor's primary function is to reduce the line current while greatly improving the torque characteristics of a motor. The capacitor also reduces the line current to the motor by improving the power factor of the load. The line side of the capacitor is marked with a red dot and is wired to the line side of the circuit (see Figure 10.)

## CAPACITOR - TEST

1. Remove capacitor from unit.
2. Check for visual damage such as bulges, cracks, or leaks.
3. For dual rated, apply an ohmmeter lead to common (C) terminal and the other probe to the compressor (HERM) terminal. A satisfactory capacitor will cause a deflection on the pointer, then gradually move back to infinity.
4. Reverse the leads of the probe and momentarily touch the capacitor terminals. The deflection of the pointer should be two times that of the first check if the capacitor is good.
5. Repeat steps 3 and 4 to check fan motor capacitor.

NOTE: A shorted capacitor will indicate a low resistance and the pointer will move to the "0" end of the scale and remain there as long as the probes are connected.

An open capacitor will show no movement of the pointer when placed across the terminals of the capacitor.

## THERMOSTAT ("WS" Models)

Thermostat part number 613-503--10 (see Figure 11) is used to cycle the unit "on" and "off" at the comfort level desired.

The thermostat has a range from 60° F  $\pm 2^\circ$  to 90° F  $\pm 5^\circ$ , with a differential of 5½° F. Turning the control knob clockwise lowers the indoor temperature setting, while turning the control knob counterclockwise raises the indoor temperature setting. The comfort range as listed on the control panel is numbered from 1 through 9 (see Figure 6.)

### TEST:

Remove wires from thermostat. Turn thermostat to its coldest position. Check to see if there is continuity between the two terminals. Turn the thermostat to its warmest position. Check continuity to see if thermostat contacts open. NOTE: Temperature must be within range listed to check thermostat. Refer to troubleshooting section in this manual for additional information on thermostat testing.

Figure 11: Thermostat

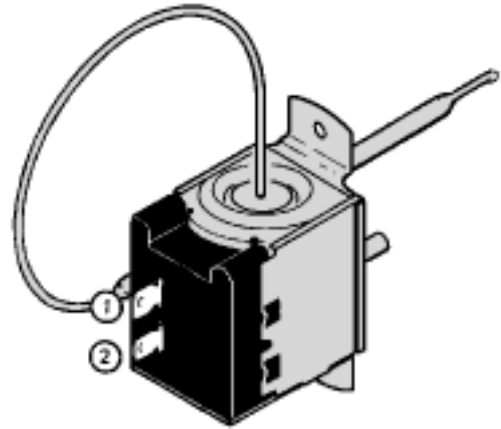

## THERMOSTAT ("WE" & "WY" Models)

Figure 12: Thermostat

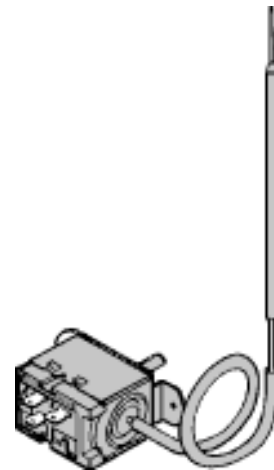

A cross ambient thermostat, part number 608-950-04 (see Figure 12) is used on all electric heat and heat pump WallMaster models.

Range from 63° F ( $\pm 2^\circ$  F) to 98° F ( $\pm 2^\circ$  F).

**TEST:**

Remove wires from thermostat and check continuity between terminal "2" (common) and "1" for heating. Also check that contacts in thermostat open after placing in either position. NOTE: Temperature must be within range listed to check thermostat.

**THERMOSTAT ADJUSTMENT**

No attempt should be made to adjust thermostat. Due to the sensitivity of the internal mechanism and the sophisticated equipment required to check the calibration, it is suggested that the thermostat be replaced rather than calibrated.

**HEATING ELEMENT  
("WE" & "WY" Models)**

All "WE" and "WY" models are equipped with a 3.3 KW heating element.

The heating element contains a fuse link and heater limit switch. The fuse link is in series with the power supply and will open and interrupt the power when the temperature reaches 183° F, or a short circuit occurs in the heating element. Once the fuse link separates, a new fuse link must be installed. NOTE: Always replace with the exact replacement.

The heater element has a high limit control. This control is a bi-metal thermostat mounted in the top of the heating element.

**Figure 13: Heating Element**

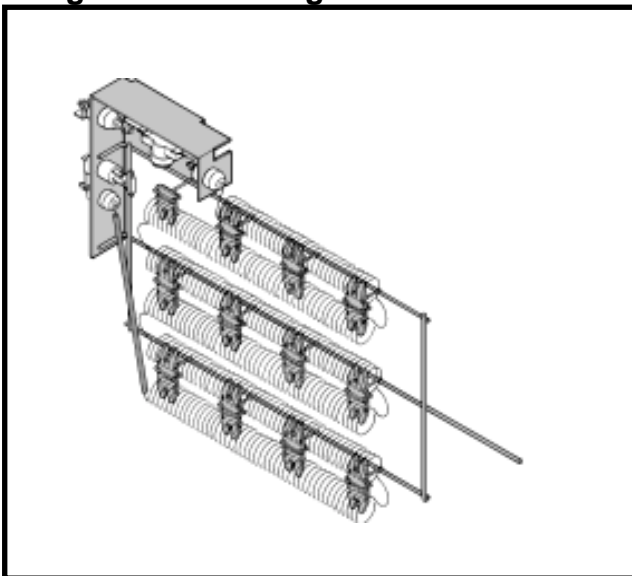

Should the fan motor fail or filter become clogged, the high limit control will open and interrupt power to the heater before reaching an unsafe temperature condition.

The control is designed to open at 120° F  $\pm$  5° F. Test continuity below 120° F and for open above 120° F.

**DEFROST THERMOSTAT  
("WY" Models Only)**

This thermostat is a single pole - double throw with contacts between terminal "2" and "3" closing on temperature rise and contacts between terminals "2" and "1" closing on temperature fall. When the contacts between terminals "2" and "3" open, power to the compressor is interrupted. When contacts between terminals "2" and "1" make, power is supplied to the heater element.

This control is a dual purpose control that acts as an outdoor thermostat and defrost control.

When the sensing bulb, attached to the condenser coil, senses enough icing on the outdoor coil it will interrupt power to the compressor and supply power to the heating element until the coil temperature reaches above 43°. Then the heater will shut off and the unit will resume operating in the reverse cycle mode.

When the outdoor coil temperature drops below 20 degrees, the unit will operate in electric heat mode continuously until the outdoor coil temperature rises above 43°.

**Figure 14: Defrost Control**

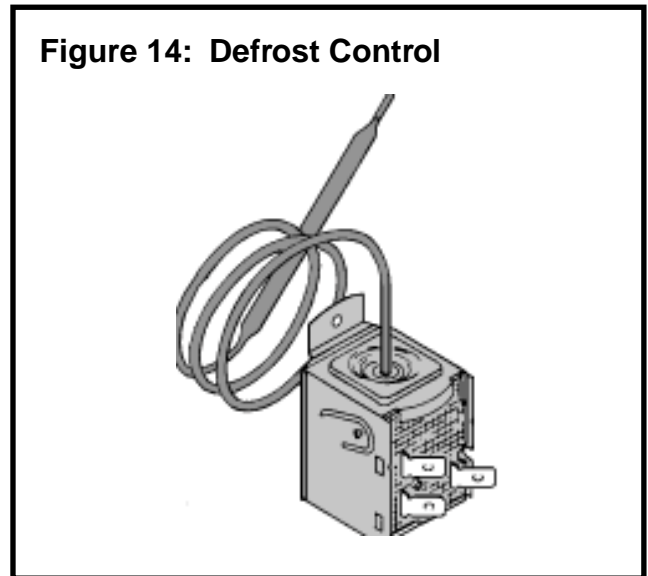

## DEFROST BULB LOCATION (All "WY" Models)

The defrost control bulb must be mounted securely and in the correct location to operate properly (see Figure 15.)

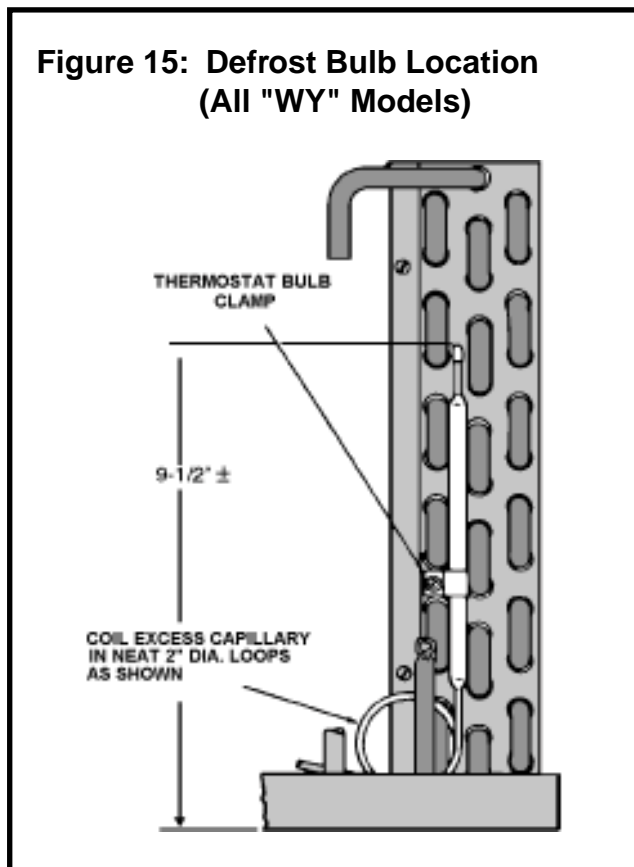

## SOLENOID COIL ("WY" Models Only)

The solenoid coil is an electromagnetic type coil mounted on the reversing valve and is energized during the operation of the compressor in the heating cycle.

Should the reversing valve fail to shift during the heating cycle, test the solenoid coil. Also, refer to Touch Test Chart on Page 24.

### TO TEST:

1. Disconnect power to unit.
2. Disconnect coil leads.
3. Attach probes of an ohmmeter to each coil lead and check for continuity.

**WARNING:** Do not start unit with solenoid coil removed from valve, or do not remove cord after unit is in operation. This will cause the coil to burn out.

## CHECK VALVE: LIQUID DRYER OPERATION HEAT PUMP

### COOLING MODE (See Figure 16)

In the cooling mode of operation, liquid refrigerant from condenser (liquid line) enters the cooling check valve forcing the heating check valve shut. The liquid refrigerant is directed into the liquid dryer after which the refrigerant is metered through cooling capillary tubes to evaporator. (Note: liquid refrigerant will also be directed through the heating capillary tubes in a continuous loop during the cooling mode).

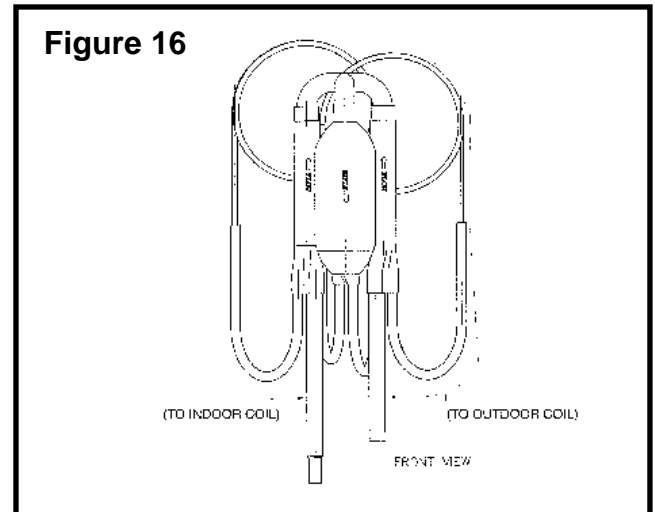

### HEATING MODE (see Figure 17)

In the heating mode of operation, liquid refrigerant from the indoor coil enters the heating check valve forcing the cooling check valve shut. The liquid refrigerant is directed into the liquid dryer after which the refrigerant is metered through the heating capillary tubes to outdoor coils. (Note: liquid refrigerant will also be directed through the cooling capillary tubes in a continuous loop during the heating mode).

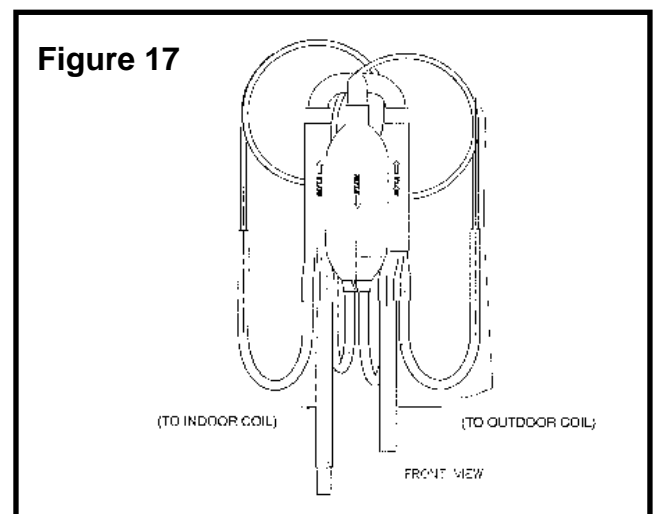

## VALVE, DRAIN PAN (See Figure 18)

During the cooling mode of operation, condensate which collects in the drain pan is picked up by the condenser fan blade and sprayed onto the condenser coil. This assists in cooling the refrigerant plus evaporating the water.

During the heating mode of operation, it is necessary that water be removed to prevent it from freezing during cold outside temperatures. This could cause the condenser fan blade to freeze in the accumulated water and prevent it from turning.

To provide a means of draining this water, a bellows type drain valve is installed over a drain opening in the base pan. This valve is temperature sensitive and will open when the outside temperature reaches 40° F. The valve will close gradually as the temperature rises above 40° F to fully close at 60° F.

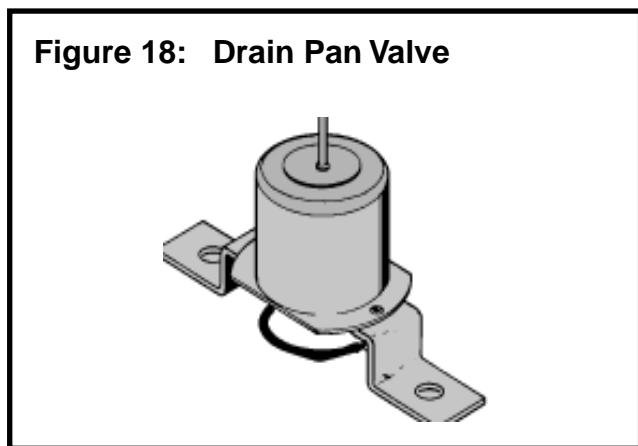

**Figure 18: Drain Pan Valve**

## REVERSING VALVE ("WY" Models Only)

A reversing valve is used to change the refrigerant flow within the system to permit heating or cooling (see Figure 19.)

The reversing valve consists of a main valve body which houses the slide and piston, plus a pivot valve which is activated by a solenoid.

There are three tubes connected to one side of the main valve body and one tube on the opposite side. The single tube is connected to the compressor discharge line. The center tube on the opposite side is the common suction line to the compressor. The outside tubes are connected to the indoor and outdoor coils.

The pivot valve is responsible for directing the refrigerant flow to the indoor or outdoor coil. There are three small tubes connected to the pivot valve body. The center pilot tube is the common pilot tube and is connected to the center suction line. The outside tubes are connected to each end of the main valve body. The pivot valve consists of a needle valve and spring. When the solenoid is deenergized, the spring tension closes one pilot port while the other remains open. When the solenoid is energized, the opposite end is closed. The piston in the main valve is pressure operated and will always travel in the direction of the open pilot tube port which provides a path to the center tube. Pressure which will increase in the opposite side of the valve will escape through a bleed port located in each piston. When deenergized, the valve will be in the cooling position.

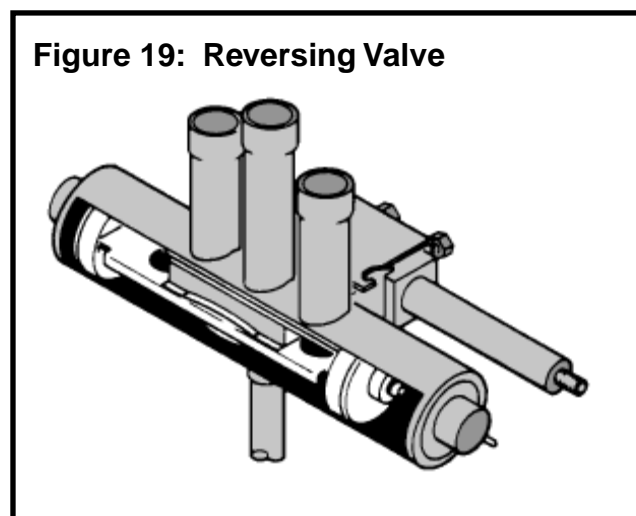

**Figure 19: Reversing Valve**

## TESTING REVERSING VALVE

Occasionally, the reversing valve may stick in the heating or cooling position or in the mid-position.

When stuck in the mid-position, part of the discharge gas from the compressor is directed back to the suction side, resulting in excessively high suction pressure.

Check the operation of the valve by starting the system and switching the operation from "Cooling" to "Heating" and then back to "Cooling". Do not hammer on valve.

If valve fails to change its position, test the voltage to the valve coil while the system is in the heating cycle. If voltage to the coil is satisfactory, replace reversing valve.

Should the valve fail to shift from cooling to heating, block the air flow through the outdoor coil and allow the discharge pressure to build in the system. Then switch the system from cooling to heating.

If the valve is stuck in the heating position, block the air flow through the indoor coil and allow discharge pressure to build in the system. Then switch the system from heating to cooling.

Should the valve fail to shift in either position after increasing the discharge pressure, replace the valve.

**NOTE:** When brazing a reversing valve into the system, it is of extreme importance that the temperature of the valve does not exceed 250° F at any time.

Wrap the reversing valve with a large rag saturated with water. "Rewet" the rag and thoroughly cool the valve after each brazing operation of the four joints involved.

The wet rag around the reversing valve will eliminate conduction of heat to the valve body when brazing the line connection.

## **SEALED REFRIGERATION SYSTEM REPAIRS**

### EQUIPMENT REQUIRED

1. Voltmeter
2. Ammeter
3. Ohmmeter
4. Vacuum Pump (capable of 200 microns or less vacuum.)
5. Acetylene Welder
6. Electronic Halogen Leak Detector (G.E. Type H-6 or equivalent.)
7. Accurate refrigerant charge measuring device such as:
  - a. Balance Scales - 1/2 oz. accuracy
  - b. Charging Board - 1/2 oz. accuracy
8. High Pressure Gauge - (0 - 400 lbs.)
9. Low Pressure Gauge - (30 - 150 lbs.)
10. Vacuum Gauge - (0 - 1000 microns)

### EQUIPMENT MUST BE CAPABLE OF:

1. Evacuation from both the high side and low side of the system simultaneously.
2. Introducing refrigerant charge into high side of the system.

3. Accurately weighing the refrigerant charge actually introduced into the system.
4. Facilities for flowing nitrogen through refrigeration tubing during all brazing processes.

## **HERMETIC COMPONENT REPLACEMENT**

The following procedure applies when replacing components in the sealed refrigeration circuit or repairing refrigerant leaks. (Compressor, condenser, evaporator, capillary tube, refrigerant leaks, etc.)

1. Recover the refrigerant from the system at the process tube located on the high side of the system by installing a line tap on the process tube. Apply gauge from process tube to EPA approved gauges from process tube to EPA approved recovery system. Recover CFCs in system to at least 5%.
2. Cut the process tube below pinch off on the suction side of the compressor.
3. Connect the line from the nitrogen tank to the suction process tube.
4. Drift dry nitrogen through the system and unsolder the more distant connection first. (Filter drier, high side process tube, etc.)
5. Replace inoperative component, and always install a new filter drier. Drift dry nitrogen through the system when making these connections.
6. Pressurize system to 30 PSIG with proper refrigerant and boost refrigerant pressure to 150 PSIG with dry nitrogen.
7. Leak test complete system with electric halogen leak detector, correcting any leaks found.
8. Reduce the system to zero gauge pressure.
9. Connect vacuum pump to high side and low side of system with deep vacuum hoses, or copper tubing. (Do not use regular hoses.)
10. Evacuate system to maximum absolute holding pressure of 200 microns or less. **NOTE:** This process can be speeded up by use of heat lamps, or by breaking the vacuum with refrigerant or dry nitrogen at 5,000 microns. Pressure system to 5 PSIG and leave in system a minimum of 10 minutes. Release refrigerant, and proceed with evacuation of a pressure of 200 microns or less.

11. Break vacuum by charging system from the high side with the correct amount of refrigerant specified. This will prevent boiling the oil out of the crankcase.

NOTE: If the entire charge will not enter the high side, allow the remainder to enter the low side in small increments while operating the unit.

12. Restart unit several times after allowing pressures to stabilize. Pinch off process tubes, cut and solder the ends. Remove pinch off tool, and leak check the process tube ends.

### **SPECIAL PROCEDURE IN THE CASE OF MOTOR COMPRESSOR BURNOUT**

1. Recover all refrigerant and oil from the system.
2. Remove compressor, capillary tube and filter drier from the system.
3. Flush evaporator condenser and all connecting tubing with dry nitrogen or equivalent, to remove all contamination from system. Inspect suction and discharge line for carbon deposits. Remove and clean if necessary.
4. Reassemble the system, including new drier strainer and capillary tube.
5. Proceed with processing as outlined under hermetic component replacement.

### **ROTARY COMPRESSOR SPECIAL TROUBLESHOOTING AND SERVICE**

Basically, troubleshooting and servicing rotary compressors is the same as on the reciprocating compressor with only a few exceptions.

1. Because of the spinning motion of the rotary, the mounts are critical. If vibration is present, check the mounts carefully.
2. The electrical terminals on the rotary are in a different order than the reciprocating compressors. The terminal markings are on the cover gasket. Use your wiring diagram to insure correct connections.

### **REFRIGERANT CHARGE**

1. The refrigerant charge is extremely critical. Measure charge carefully - as exact as possible to the nameplate charge.
2. The correct method for charging the rotary is to introduce liquid refrigerant into the high side of the system with the unit off. Then start compressor and enter the balance of the charge, gas only, into the low side.

The introduction of liquid into the low side, without the use of a capillary tube, will cause damage to the discharge valve of the rotary compressor.

NOTE: All inoperative compressors returned to Friedrich must have all lines properly plugged with the plugs from the replacement compressor.

# TROUBLESHOOTING TOUCH TEST CHART TO SERVICE REVERSING VALVES

NORMAL FUNCTION OF VALVE								
VALVE OPERATING CONDITION	DISCHARGE TUBE from Compressor	SUCTION TUBE to Compressor	Tube to INSIDE COIL	Tube to OUTSIDE COIL	LEFT Pilot Capillary Tube	RIGHT Pilot Capillary Tube	NOTES:	
	1	2	3	4	5	6	* TEMPERATURE OF VALVE BODY ** WARMER THAN VALVE BODY	
							POSSIBLE CAUSES	CORRECTIONS
Normal Cooling	Hot	Cool	Cool, as(2)	Hot, as (1)	*TVB	TVB		
Normal Heating	Hot	Cool	Hot, as(1)	Cool, as (2)	*TVB	TVB		
MALFUNCTION OF VALVE								
Valve will not shift from cool to heat.	Check Electrical circuit and coil						No voltage to coil. Defective coil.	Repair electrical circuit. Replace coil.
	Check refrigeration charge						Low charge Pressure differential too high.	Repair leak, recharge system. Recheck system.
	Hot	Cool	Cool, as (2)	Hot, as (1)	*TVB	Hot	Pilot valve okay. Dirt in one bleeder hole.	Deenergize solenoid, raise head pressure, reenergize solenoid to break dirt loose. If unsuccessful, remove valve, wash out. Check on air before installing. If no movement, replace valve, add strainer to discharge tube, mount valve horizontally.
							Piston cup leak	Stop unit. After pressures equalize, restart with solenoid energized. If valve shifts, reattempt with compressor running. If still no shift, replace valve.
Valve will not shift from cool to heat.	Hot	Cool	Cool, as (2)	Hot, as (1)	*TVB	*TVB	Clogged pilot tubes.	Raise head pressure, operate solenoid to free. If still no shift, replace valve.
	Hot	Cool	Cool, as (2)	Hot, as (1)	Hot	Hot	Both ports of pilot open. (Back seat port did not close).	Raise head pressure, operate solenoid to free partially clogged port. If still no shift, replace valve.
	Warm	Cool	Cool, as (2)	Warm, as (1)	*TVB	Warm	Defective Compressor	
Starts to shift but does not complete reversal.	Hot	Warm	Warm	Hot	*TVB	Hot	Not enough pressure differential at start of stroke or not enough flow to maintain pressure differential.	Check unit for correct operating pressures and charge. Raise head pressure. If no shift, use valve with smaller port.
							Body damage	Replace valve
	Hot	Warm	Warm	Hot	Hot	Hot	Both ports of pilot open.	Raise head pressure, operate solenoid. If no shift, replace valve.
	Hot	Hot	Hot	Hot	*TVB		Body damage	Replace valve
						Hot	Valve hung up at mid-stroke. Pumping volume of compressor not sufficient to maintain reversal.	Raise head pressure, operate solenoid. If no shift, use valve with smaller ports.
Apparent leap in heating.	Hot	Warm	Warm	Hot	Hot	Hot	Both ports of pilot open.	Raise head pressure, operate solenoid. If no shift, replace valve.
	Hot	Cool	Hot, as (1)	Cool, as (2)	*TVB	*TVB	Piston needle on end of slide leaking.	Operate valve several times, then recheck. If excessive leak, replace valve.
Will not shift from heat to cool.	Hot	Cool	Hot, as (1)	Cool, as (2)	*TVB	WVB *TVB	Pilot needle and piston needle leaking	Operate valve several times, then recheck. If excessive leak, replace valve.
							Pressure differential too high	Stop unit. Will reverse during equalization period. Recheck system
							Clogged pilot tube.	Raise head pressure, operate solenoid to free dirt. If still no shift, replace valve.
	Hot	Cool	Hot, as (1)	Cool, as (2)	Hot	*TVB	Dirt in bleeder hole.	Raise head pressure, operate solenoid. Remove valve and wash out. Check on air before reinstalling, if no movement, replace valve. Add strainer to discharge tube. Mount valve horizontally.
	Hot	Cool	Hot, as (1)	Cool, as (2)	Hot	*TVB	Piston cup leak	Stop unit. After pressures equalize, restart with solenoid deenergized. If valve shifts, reattempt with compressor running. If it still will not reverse while running, replace the valve.
	Hot	Cool	Hot, as (1)	Cool, as (2)	Hot	Hot	Defective pilot.	Replace valve.
	Warm	Cool	Warm, as (1)	Cool, as (2)	Warm	*TVB	Defective compressor.	

Valve operated satisfactorily PRIOR to compressor motor burnout – caused by dirt and small greasy particles inside the valve. TO CORRECT: Remove valve, thoroughly wash it out. Check on air before reinstalling, or replace valve. Add strainer and filter-drier to discharge tube between valve and compressor.

## TROUBLESHOOTING COOLING

PROBLEM	POSSIBLE CAUSE	TO CORRECT
Compressor does not run.	Low voltage.	Check for voltage at compressor. 115 volt and 230 volt units will operate at 10% voltage variance
	Thermostat not set cold enough or inoperative.	Set thermostat to coldest position. Test thermostat and replace if inoperative.
	Compressor hums but cuts off on overload.	Hard start compressor. Direct test compressor. If compressor starts, add starting components.
	Open or shorted compressor windings.	Check for continuity and resistance.
	Open overload.	Test overload protector and replace if inoperative.
	Open capacitor.	Test capacitor and replace if inoperative.
	Inoperative system switch.	Test for continuity in all positions. Replace if inoperative.
	Broken, loose or incorrect wiring.	Refer to appropriate wiring diagram to check wiring.

PROBLEM	POSSIBLE CAUSE	TO CORRECT
Fan motor does not run.	Inoperative system switch.	Test switch and replace if inoperative.
	Broken, loose or incorrect wiring.	Refer to applicable wiring diagram.
	Open Capacitor.	Test capacitor and replace if inoperative.
	Fan speed switch open.	Test switch and replace if inoperative.
	Inoperative fan motor.	Test fan motor and replace if inoperative. (Be sure internal overload has had time to reset.)

PROBLEM	POSSIBLE CAUSE	TO CORRECT
Does not cool, or cools only slightly.	Undersized unit.	Refer to Sizing Charts.
	Thermostat open or inoperative.	Set to coldest position. Test thermostat and replace if necessary.
	Dirty filter.	Clean as recommended in Owner's Manual.
	Dirty or plugged condenser or evaporator coil.	Use steam or detergents to clean.
	Poor air circulation in area being cooled.	Adjust discharge air louvers. Use high fan speed.
	Fresh air or exhaust air door open on applicable models.	Close doors. Instruct customer on use of this feature.
	Low capacity – undercharge.	Check for leak and make repair.
	Compressor not pumping properly.	Check amperage draw against nameplate. If not conclusive, make pressure test.

PROBLEM	POSSIBLE CAUSE	TO CORRECT
Unit does not run.	Fuse blown or circuit tripped.	Replace fuse, reset breaker. If repeats, check fuse or breaker size. Check for shorts in unit wiring and components.
	Power cord not plugged in.	
	System switch in "Off" position.	Set switch correctly.
	Inoperative system switch.	Test for continuity in each switch position.
	Loose or disconnected wiring at switch or other components.	Check wiring and connections. Reconnect per wiring diagram.

PROBLEM	POSSIBLE CAUSE	TO CORRECT
Evaporator coil freezes up.	Dirty filter.	Clean as recommended in Owner's Manual.
	Restricted air flow.	Check for dirty or obstructed coil - clean as required.
	Inoperative thermostat.	Test for shorted thermostat or stuck contacts.
	Short of refrigerant.	De-ice coil and check for leak.
	Inoperative fan motor.	Test fan motor and replace if inoperative.
	Partially restricted capillary.	De-ice coil. Check temp. differential across coil. Touch test coil return bends for same temperature. Test for low running current. Turn to higher temperature setting to see if unit cycles off. Refer to appropriate wiring diagram. Refer to Sizing Chart.

PROBLEM	POSSIBLE CAUSE	TO CORRECT:
Compressor runs continually. Does not cycle off.	Excessive heat load.	Unit undersized. Test cooling performance of unit. Replace with larger unit.
	Restriction in line.	Check for partially iced coil. Check temperature split across coil.
	Refrigerant leak.	Check for oil at silver soldered connections.
		Check for partially iced coil. Check split across coil. Check for low running amperage.
	Thermostat contacts stuck	Check operation of thermostat. Replace if contacts remain closed.
	Thermostat incorrectly wired.	Refer to appropriate wiring diagram.

PROBLEM	POSSIBLE CAUSE	TO CORRECT:
Thermostat does not turn unit off.	Thermostat contacts stuck.	Replace thermostat.
	Thermostat set at coldest point.	Turn to higher temperature setting to see if the unit cycles off.
	Incorrect wiring.	Refer to appropriate wiring diagram.
	Unit undersized for area to be cooled.	Refer to Sizing Chart.

<b>PROBLEM</b>	<b>POSSIBLE CAUSE</b>	<b>TO CORRECT</b>
Compressor attempts to start, or runs for short periods only. Cycles on overload.	Overload inoperative. Opens too soon.	Check operation of unit. Replace overload if system operation is satisfactory.
	Compressor attempts to start before system pressures are equalized.	Allow a minimum of two (2) minutes for pressures to equalize before attempting to restart. Instruct customer of waiting period.
	Low or fluctuating voltage.	Check voltage with unit operating. Check for other appliances on circuit. Air conditioner should be on separate circuit for proper voltage, and be fused separately.
	Incorrect wiring.	Refer to appropriate wiring diagram.
	Shorted or incorrect capacitor.	Check by substituting a known good capacitor of correct rating.
	Restricted or low air flow through condenser coil.	Check for proper fan speed or blocked condenser.
	Compressor running abnormally hot.	Check for kinked discharge line or restricted condenser. Check amperage.

<b>PROBLEM</b>	<b>POSSIBLE CAUSE</b>	<b>TO CORRECT</b>
Thermostat does not turn unit on.	Loss of charge in thermostat bulb.	Place jumper across thermostat terminals to check if unit operates. If unit operates, replace thermostat.
	Loose or broken parts in thermostat.	Check as above.
	Incorrect wiring.	Refer to appropriate wiring diagram.

<b>PROBLEM</b>	<b>POSSIBLE CAUSE</b>	<b>TO CORRECT</b>
Noisy operation.	Poorly installed unit.	Refer to Installation Instructions for proper installation.
	Fan blade striking chassis.	Reposition - adjust motor mount.
	Compressor vibrating.	Check that compressor grommets have not deteriorated. Check that compressor mounting parts are not missing.
	Improperly mounted or loose cabinet parts.	Check assembly and parts for looseness, rubbing and rattling.

<b>PROBLEM</b>	<b>POSSIBLE CAUSE</b>	<b>TO CORRECT</b>
Water leaks into room.	Evaporator drain pan overflowing.	Clean obstructed drain trough.
	Condensation forming on base pan.	Evaporator drain pan broken or cracked. Reseal or replace.
	Poor installation resulting in rain entering room.	Check Installation Instructions. Reseal as required.
	Condensation on discharge grilles.	Dirty evaporator coil - clean. Very high humidity level.

PROBLEM	POSSIBLE CAUSE	TO CORRECT
Thermostat short cycles.	Thermostat differential too narrow.	Replace thermostat.
	Plenum gasket not sealing, allowing discharge air to short cycle thermostat.	Check gasket. Reposition or replace.
	Restricted coil or dirty filter.	Clean and advise customer of periodic cleaning of filter.
	Tubular insulation missing from top of thermostat bulb.	Replace tubular insulation on bulb. (Applicable models.)
	Thermostat bulb touching thermostat bulb support bracket.	Adjust bulb bracket. (Applicable models.)

PROBLEM	POSSIBLE CAUSE	TO CORRECT
Prolonged off-cycles. (automatic operation)	Anticipator (resistor) wire disconnected at thermostat or system switch.	Refer to appropriate wiring diagram.
	Anticipator (resistor shorted or open). (Applicable models.)	Disconnect plug from outlet. Remove resistor from bracket. Insert plug and depress "Cool" and "Fan - Auto (MoneySaver)" buttons. Place thermostat to warmest setting. Feel resistor for temperature. If no heat, replace resistor.
	Partial loss of charge in thermostat bulb causing a wide differential.	Replace thermostat.

PROBLEM	POSSIBLE CAUSE	TO CORRECT
Switches from cooling to heating.	Thermostat sticking.	Change room thermostat.
	Incorrect wiring.	Refer to appropriate wiring diagram.

PROBLEM	POSSIBLE CAUSE	TO CORRECT
Outside water leaks.	Evaporator drain pan cracked or obstructed.	Repair, clean or replace as required.
	Water in compressor area.	Detach shroud from pan and coil. Clean and remove old sealer. Reseal, reinstall and check.
	Obstructed condenser coil.	Steam clean.
	Fan blade and slinger ring improperly positioned.	Adjust fan blade to 1/2" clearance from condenser coil.

PROBLEM	POSSIBLE CAUSE	TO CORRECT
High indoor humidity.	Insufficient air circulation in air conditioned area.	Adjust louvers for best possible air circulation
	Oversized unit.	Operate in "Fan-Auto (MoneySaver)" position.
	Inadequate vapor barrier in building structure, particularly floors.	Advise customer.

# Troubleshooting Heating (Heat pumps)

PROBLEM	POSSIBLE CAUSE	TO CORRECT
No heating — fan operates.	Thermostat setting.	Set thermostat to a warmer position.
	Defective thermostat.	Replace — do not attempt to adjust.
	Compressor not operating.	Check compressor wiring. Check for open internal or external overload. Check wiring.
	Defective system switch.	Test system switch

PROBLEM	POSSIBLE CAUSE	TO CORRECT
Insufficient heating.	Restricted filter.	Clean as recommended in Owner's Manual.
	Outdoor thermostat. (Applicable models.)	Check if outdoor thermostat is energizing the heating element at its predetermined temperature setting
	Fresh air or exhaust door open.	Check control setting.

PROBLEM	POSSIBLE CAUSE	TO CORRECT
Fan operates in "constant" position, but not in "automatic" (MoneySaver).	Inoperative system switch.	Check continuity of switch.
	Incorrect wiring.	Check applicable wiring diagram.

PROBLEM	POSSIBLE CAUSE	TO CORRECT
Temperature varies from comfortable to overly warm.	Defective thermostat.	Incorrect differential setting. Replace thermostat.
	Heat anticipator (resistor) shorted. (Applicable models)	Check voltage to resistor. If voltage okay, remove resistor from thermostat bulb block. With current on, feel resistor for warmth. If no heat can be felt, replace anticipator.

PROBLEM	POSSIBLE CAUSE	TO CORRECT
Room temperature uneven. (Heating cycle)	Heat anticipator (resistor) shorted. (Applicable models.)	Disconnect power to unit. Remove resistor from thermostat bulb block. Plug in unit and allow to operate. Feel resistor for heat. If no heat is felt, replace resistor.
	Wide differential — partial loss of thermostat bulb charge.	Replace thermostat and check.
	Incorrect wiring.	Refer to appropriate wiring diagram. Resistor is energized during the "on" cycle of compressor or fan.

PROBLEM	POSSIBLE CAUSE	TO CORRECT
Unit will not defrost.	Incorrect wiring.	Refer to appropriate wiring diagram.
	Defrost control timer motor not advancing.	Check for voltage at "TM" and "TM1" on timer. If voltage, replace control.
	Defrost control out of calibration.	If outside coil temperature is 25° F or below, and preselected time limit has elapsed, replace the defrost control.
	Defrost control contacts stuck.	If the contacts remain closed between terminals "2" and "3" of the defrost control after preselected time interval has passed, replace control.
	Defrost control bulb removed from coil, or not making good coil contact.	Reinstall and assure that good bulb to coil contact is made.

PROBLEM	POSSIBLE CAUSE	TO CORRECT
Unit does not heat adequately.	Outdoor thermostat does not cut off compressor at the preselected temperature and bring on the heating element.	Defective thermostat — replace.
	Fresh air or exhaust door open.	Check if operating properly. Instruct customer on proper use of control.
	Dirty filter.	Clean as recommended in Owner's Manual
	Unit undersized.	Check heat rise across coil. Refer to performance data sheet on heat rise at various outdoor ambients. If heat rise is satisfactory, check if insulation can be added to attic or walls.

PROBLEM	POSSIBLE CAUSE	TO CORRECT
Unit cools when heat is called for.	Incorrect wiring.	Refer to applicable wiring diagram.
	Defective solenoid coil.	Check for continuity of coil.
	Reversing valve fails to shift.	Block condenser coil and switch unit to cooling. Allow pressure to build up in the system, then switch to heating. If valve fails to shift, replace valve.
	Inoperative system switch.	Check for continuity of system switch.

PROBLEM	POSSIBLE CAUSE	TO CORRECT
Cooling adequate — heating insufficient.	Heating capillary tube partially restricted.	Check for partially starved outer coil. Replace heating capillary tube.
	Check valve leaking internally.	Switch unit several times from heating to cooling. Check temperature rise across the coil. Refer to specification sheet for correct temperature rise.
	Reversing valve failing to shift completely — bypassing hot gas.	Deenergize solenoid coil, raise head pressure, energize solenoid to break loose. If valve fails to make complete shift, replace valve.

PROBLEM	POSSIBLE CAUSE	TO CORRECT
Compressor will not turn off and operate on heating element only during low outside ambients.	Outdoor thermostat. (Applicable models.)	Refer to the heating data on applicable models for the preselected temperature the compressor shuts off and the electric element is energized.

PROBLEM	POSSIBLE CAUSE	TO CORRECT
Compressor shuts off on outdoor thermostat but element does not heat.	Fuse link.	Check fuse link for continuity. If defective, replace.
	Heating element shorted.	Check amperage draw of element. If no amperage, replace.
	Incorrect wiring.	Check voltage to element. If voltage is okay, check wiring.
	Heat relay or heater contactor coil open.	Defective coil. Test coil for continuity.

# Troubleshooting Heating

(Cooling/Electric Models)

PROBLEM	POSSIBLE CAUSE	TO CORRECT
Fan Operates – heating element does not come on.	Heater relay or contactor coil open.	Check continuity of coil.
	Heater relay or contactor stuck open, pitted or burned.	Inspect, test continuity with ohmmeter.
	High limit control open.	Check continuity – if open, replace.
	Open thermal fuse.	Check continuity. Check reason for failure.
	Open or shorted element.	Check voltage across heater terminals. Check amperage draw of heater.
	Loose connections.	Tighten all terminals.

PROBLEM	POSSIBLE CAUSE	TO CORRECT
Heating inadequate.	Restricted filter.	Clean as recommended in Owner's Manual.
	Cycling high limit control.	Control is set to open at 120°F± 5°F and close at 90°F± 6°F. If cycling prematurely, replace control. Check position of fresh air door control slide.
	Exhaust or fresh air door open.	Adjust cable if door does not close properly.

PROBLEM	POSSIBLE CAUSE	TO CORRECT
Fan operates in "Constant" position, but not in "Automatic" (MoneySaver).	Fan relay contacts open.	Check continuity of fan relay. NOTE: Some models have the fan relay energized during the heating cycle while others do not.
	Inoperative system switch.	Check continuity between terminals "L2" and "3" of the system switch.
	Loose connection.	Check connections on system switch and fan relay.

PROBLEM	POSSIBLE CAUSE	TO CORRECT
Long "off" and "on" cycles.	Heat anticipator (resistor) shorted.	Disconnect power to unit. Remove resistor from thermostat bulb block. Plug in unit and allow to operate. Feel resistor for heat. If no heat is felt, replace resistor.
	Defective thermostat.	Replace thermostat and check operation.

PROBLEM	POSSIBLE CAUSE	TO CORRECT
Fan motor does not operate in "Constant" or "MoneySaver" position.	Defective motor.	Check and replace.
	Open or shorted capacitor.	Replace capacitor and check.
	Condenser fan frozen to base pan.	Check if drain pan valve is open. If not, replace.
	Loose connections.	Check all connections. Check voltage to fan motor

PROBLEM	POSSIBLE CAUSE	TO CORRECT
Cooling adequate, heating insufficient.	Heating capillary tube partially restricted.	Check for partially starved outer coil. Replace heating capillary tube.
	Check valve leaking internally.	Switch unit several times from heating to cooling. Check temperature rise across coil. Refer to specification sheet for correct temperature rise.
	Reversing valve failing to shift completely – bypassing hot gas.	Deenergize solenoid coil, raise head pressure, energize solenoid to break loose. If valve fails to make complete shift, replace valve.

PROBLEM	POSSIBLE CAUSE	TO CORRECT
Compressor will not turn off and operate on heating element only during low outside ambients.	Outdoor thermostat. (Applicable models.)	Refer to the heating data on applicable models for the preselected temperature the compressor shuts off and the electric element is energized.

PROBLEM	POSSIBLE CAUSE	TO CORRECT
Compressor shuts off on outdoor thermostat but, element does not heat.	Fuse link.	Check fuse link for continuity. If defective, replace.
	Heating element shorted.	Check amperage draw of element. If no amperage, replace.
	Incorrect wiring.	Check voltage to element. If voltage is okay, check wiring.
	Heat relay or heater contactor coil open.	Defective coil. Test coil for continuity.

# Troubleshooting Heating

## (Cooling/Electric Models)

PROBLEM	POSSIBLE CAUSE	TO CORRECT
Fan operates – heating element does not come on.	Heater relay or contactor coil open.	Check continuity of coil.
	Heater relay or contactor stuck open, pitted or burned.	Inspect, test continuity with ohmmeter.
	High limit control open.	Check continuity – if open, replace.
	Open Thermal fuse.	Check Continuity. Check reason for failure.
	Open or shorted element.	Check voltage across heater terminals. Check amperage draw of heater.
	Loose connections.	Tighten all terminals.

PROBLEM	POSSIBLE CAUSE	TO CORRECT
Heating inadequate.	Restricted filter. Cycling high limit control.	Clean as recommended in Owner's Manual. Control is set to open at 155°F ± 5°F and close at 130°F ± 8°F. If cycling prematurely, replace control.
	Exhaust or fresh air door open.	Check position of fresh air door control slide. Adjust cable if door does not close properly.

PROBLEM	POSSIBLE CAUSE	TO CORRECT
Fan operates in the "Constant" position, but not in "Automatic."	Fan relay contacts open.	Check continuity of fan relay. NOTE: Some models have the fan relay energized during the heating cycle while others do not.
	Inoperative system switch.	Check continuity between terminals "L2" and "3" of the system switch.
	Loose connection.	Check connections on system switch and fan relay.

PROBLEM	POSSIBLE CAUSE	TO CORRECT
Long "off" and "on" cycles.	Heat anticipator (resistor) shorted.	Disconnect power to the unit. Remove the resistor from the thermostat bulb block. Plug in the unit and allow to operate. Feel the resistor for heat. If no heat is felt, replace the resistor.
	Defective thermostat.	Replace thermostat and check operation.

PROBLEM	POSSIBLE CAUSE	TO CORRECT
Fan motor does not operate in "Constant" or "MoneySaver" position.	Defective motor	Check and replace.
	Open or shorted capacitor.	Replace capacitor and check.
	Condenser fan frozen to base pan.	Check if drain pan valve is open, if not, replace.
	Loose connections.	Check all connections. Check voltage to fan motor.

PROBLEM	POSSIBLE CAUSE	TO CORRECT
Cooling adequate, heating insufficient.	Heating capillary tube partially restricted.	Check for partially starved outer coil. Replace heating capillary tube.
	Check valve leaking internally.	Switch unit several times from heating to cooling. Check temperature rise across coil. Refer to specification sheet for correct temperature rise. Deenergize solenoid coil, raise head pressure, energize solenoid to break loose. If valve fails to make complete shift, replace valve.
	Reversing valve failing to shift completely – bypassing hot gas.	

PROBLEM	POSSIBLE CAUSE	TO CORRECT
Compressor will not turn off and operate on heating element only during low outside ambients.	Outdoor thermostat (Applicable models.)	Refer to the heating data on applicable models for the preselected temperature the compressor shuts off and the electric element is energized.

PROBLEM	POSSIBLE CAUSE	TO CORRECT
Compressor shuts off on outdoor thermostat but, element does not heat.	Fuse link.	Check fuse link for continuity. If defective, replace.
	Heating element shorted.	Check amperage draw of element. If no amperage, replace.
	Incorrect wiring.	Check voltage to element. If voltage is okay, check wiring.
	Heat relay or heater contactor coil open.	Defective coil. Test coil for continuity.

WIRING DIAGRAM FOR MODELS WS07A10B, WS10A10B, WS12A10E-B, WS12A30E-B, WS15A30B

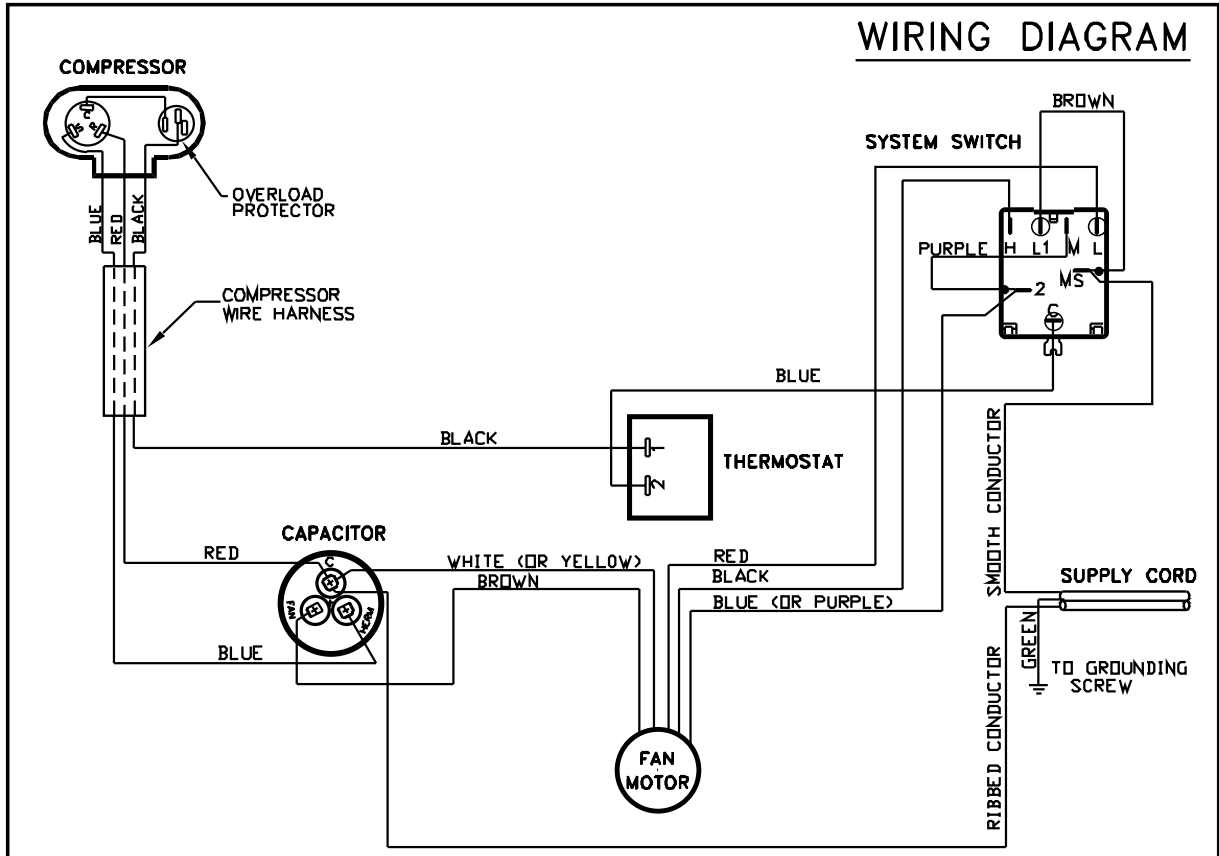

### SCHEMATIC

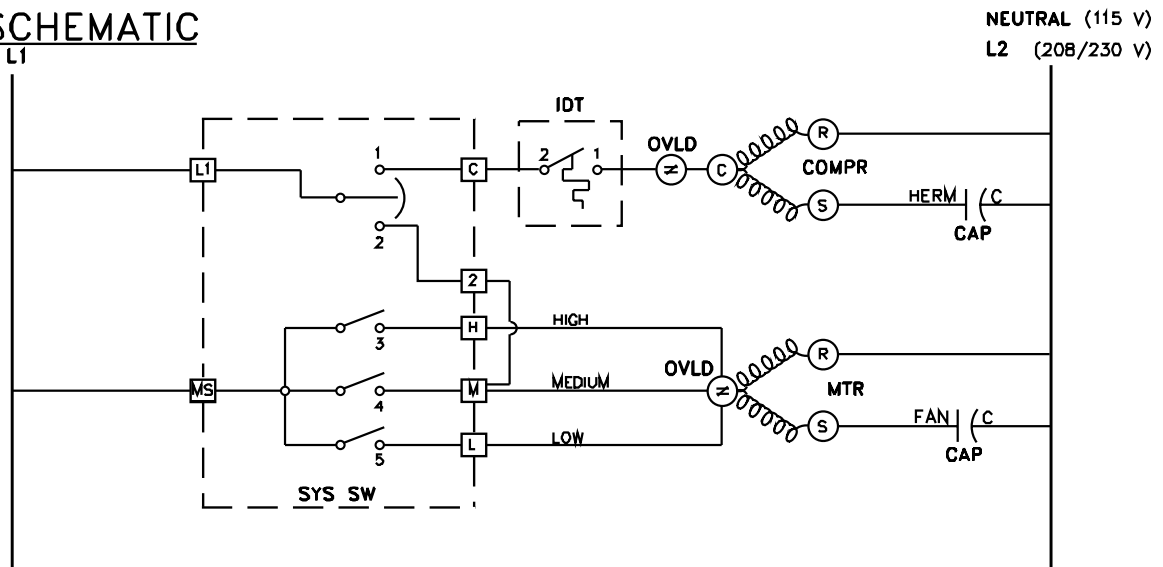

#### SWITCH LOGIC

X = CLOSED  
O = OPEN

SWITCH POSITION	1	2	3	4	5
OFF	O	O	O	O	O
LOW COOL	X	O	O	O	X
MED COOL	X	O	O	X	O
HI COOL	X	O	X	O	O
FAN ONLY	O	X	O	O	O

#### LEGEND

CAP - CAPACITOR  
 COMPR - COMPRESSOR  
 MTR - FAN MOTOR  
 OVLD - OVERLOAD PROTECTOR  
 SYS SW - SYSTEM SWITCH  
 IDT - INDOOR THERMOSTAT

—||— - GROUND LEAD  
 ●— - COMBINATION TERMINAL  
 ○ - PLASTIC INSULATOR

PART NO. 617-581-19  
 REV. 00

# WIRING DIAGRAM FOR MODELS WE09A33E-C, WE12A33E-B, WE15A33B

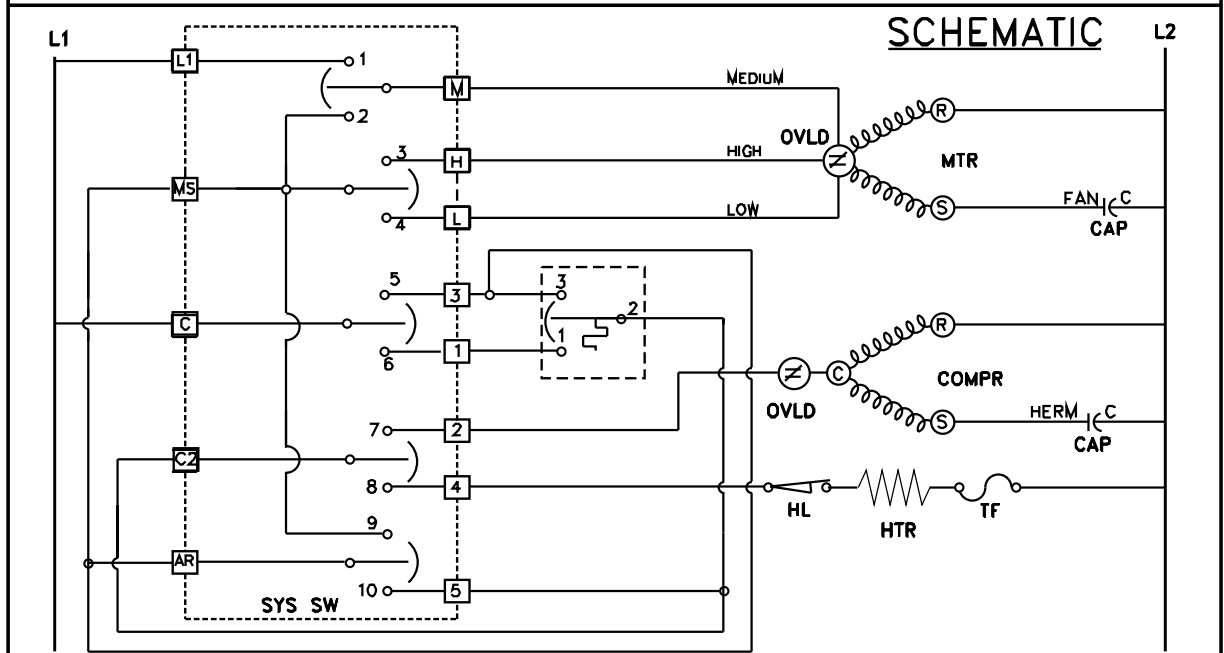
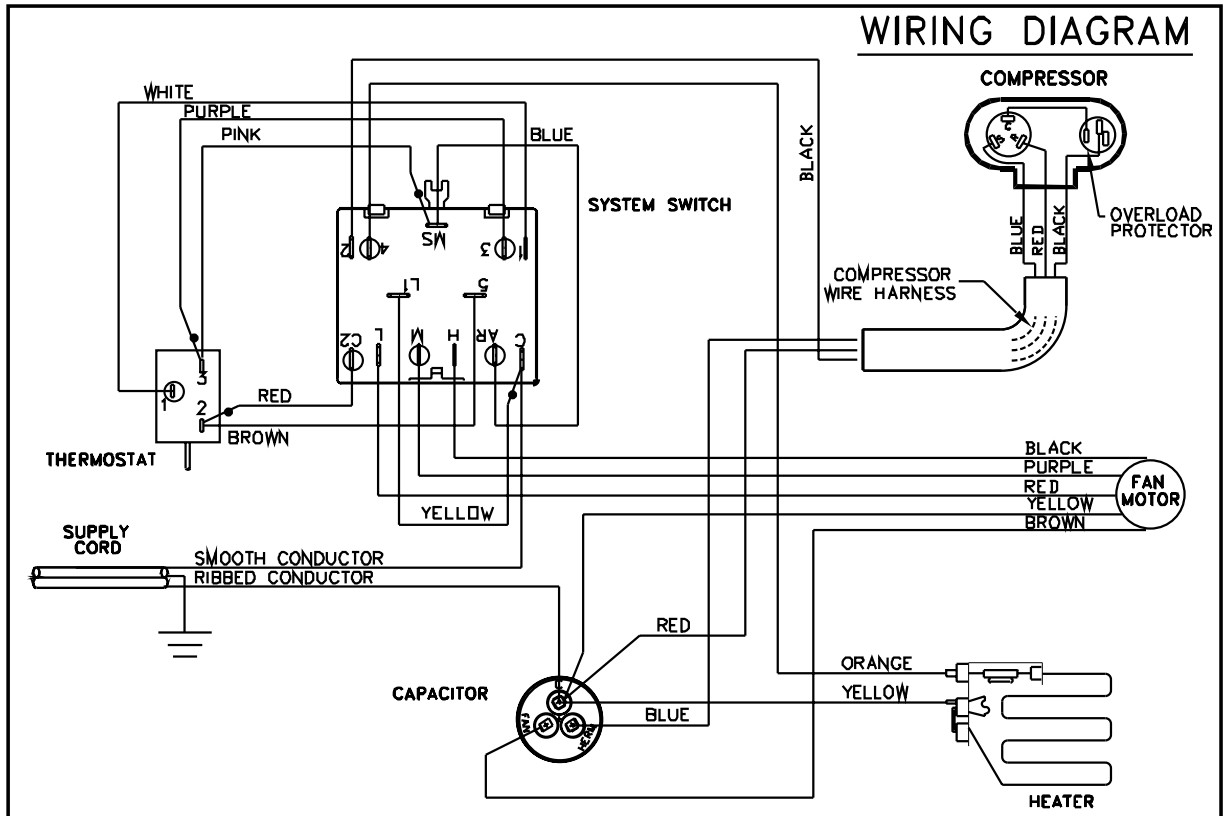

SWITCH LOGIC		LEGEND	
SWITCH POSITION	CIRCUIT	AR	HTR
OFF	0 0 0 0 0 0 0 0 0 0	MS - MONEY SAVER/ROCKER SWITCH	HL - HEATER LIMIT
LOW COOL	0 0 0 X 0 0 0 X 0 0	CAP - CAPACITOR	TF - THERMAL FUSE
MEDIUM COOL	0 X 0 0 X 0 0 X 0 0	COMPR - COMPRESSOR	— —   GROUND LEAD
HIGH COOL	0 0 X 0 0 X 0 0 X 0	MTR - FAN MOTOR	○ — COMBINATION TERMINAL
HIGH HEAT	0 0 X 0 0 X 0 0 X 0	OVLD - OVERLOAD PROTECTOR	○ — PLASTIC INSULATOR
MEDIUM HEAT	0 X 0 0 0 X 0 0 X 0	SYS SW - SYSTEM SWITCH	
LOW HEAT	0 0 0 X 0 0 X 0 0 X	IDT - INDOOR THERMOSTAT	
FAN ONLY	X 0 0 0 0 0 0 0 0 0		

PART NO. 617-581-15 REV. 00

# WIRING DIAGRAM FOR MODELS WY09A33F-A, WY12A33G-A

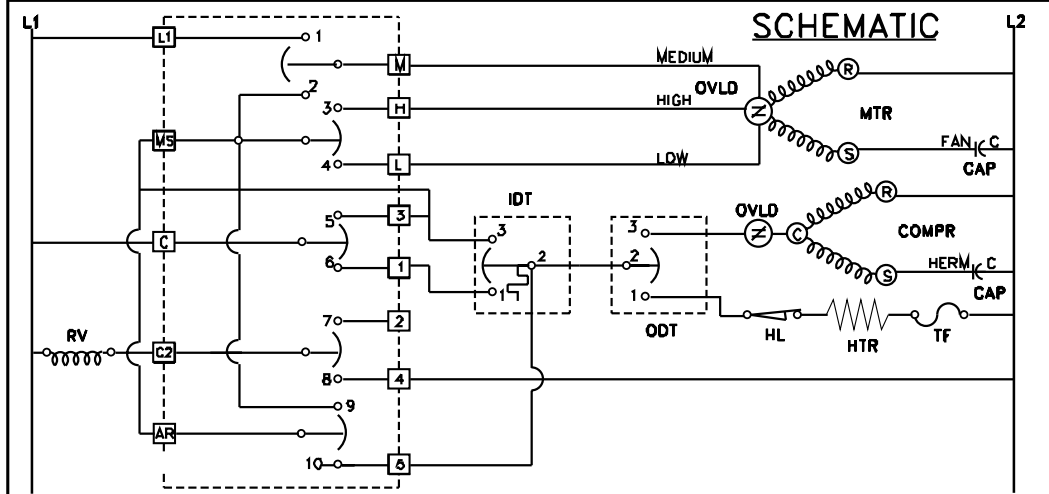
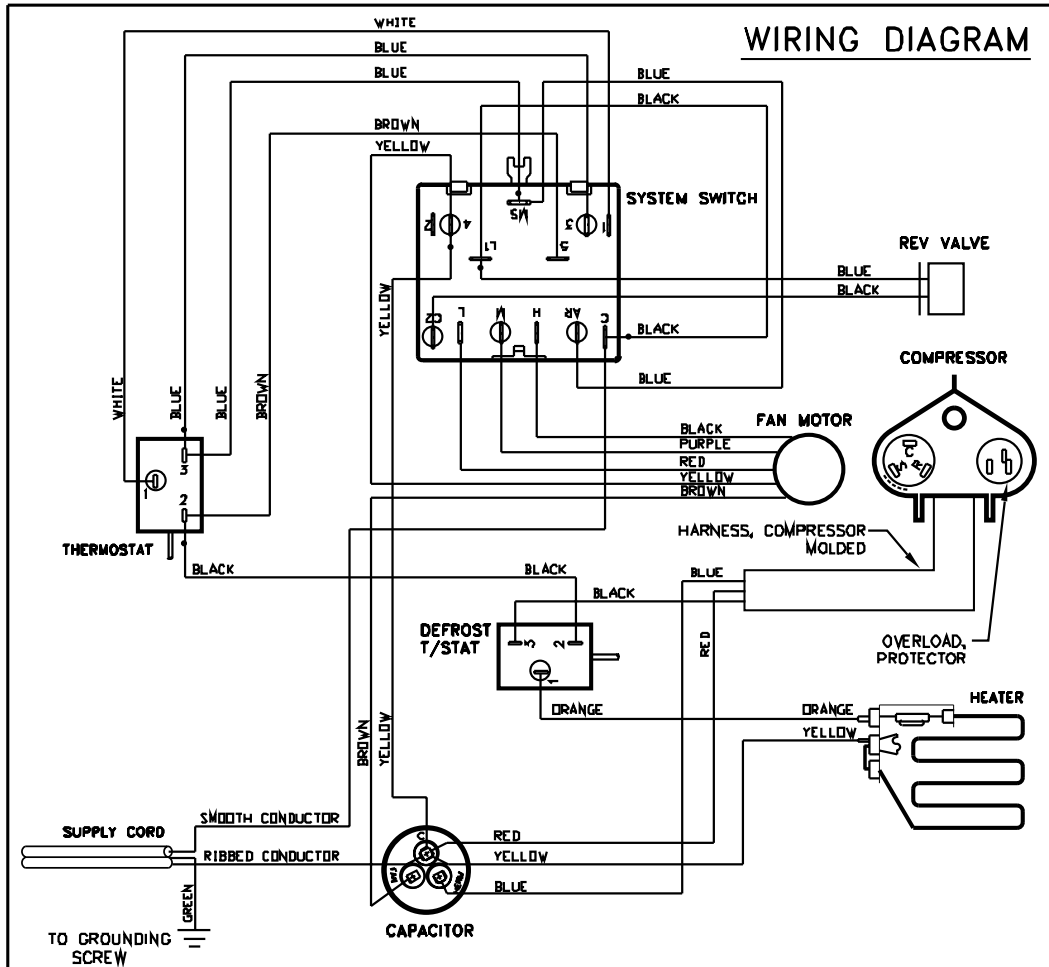

**SWITCH LOGIC**

X = CLOSED  
O = OPEN

SWITCH POSITION	1	2	3	4	5	6	7	8	9	10
OFF	O	O	O	O	O	O	O	O	O	O
LOW COOL	O	O	O	X	X	O	X	O	X	O
MEDIUM COOL	O	X	O	O	X	O	X	O	X	O
HIGH COOL	O	O	X	O	X	O	X	O	X	O
HIGH HEAT	O	O	X	O	O	X	O	X	O	X
MEDIUM HEAT	O	X	O	O	X	O	X	O	X	O
LOW HEAT	O	O	X	O	X	O	X	O	X	O
FAN ONLY	X	O	O	O	O	O	O	O	O	O

**LEGEND**

- MS - MONEY SAVER
- CAP - CAPACITOR
- CMPR - COMPRESSOR
- MTR - FAN MOTOR
- OVLD - OVERLOAD PROTECTOR
- RV - REVERSING VALVE
- IDT - INDOOR THERMOSTAT
- ODT - OUTDOOR THERMOSTAT
- HTR - HEATER
- HL - HEATER LIMIT
- TF - THERMAL FUSE
- |— | - GROUND LEAD
- - COMBINATION TERMINAL
- - PLASTIC INSULATOR

PART NO. 617-581-02 REV. 03

# "WS" SERIES CHASSIS PARTS

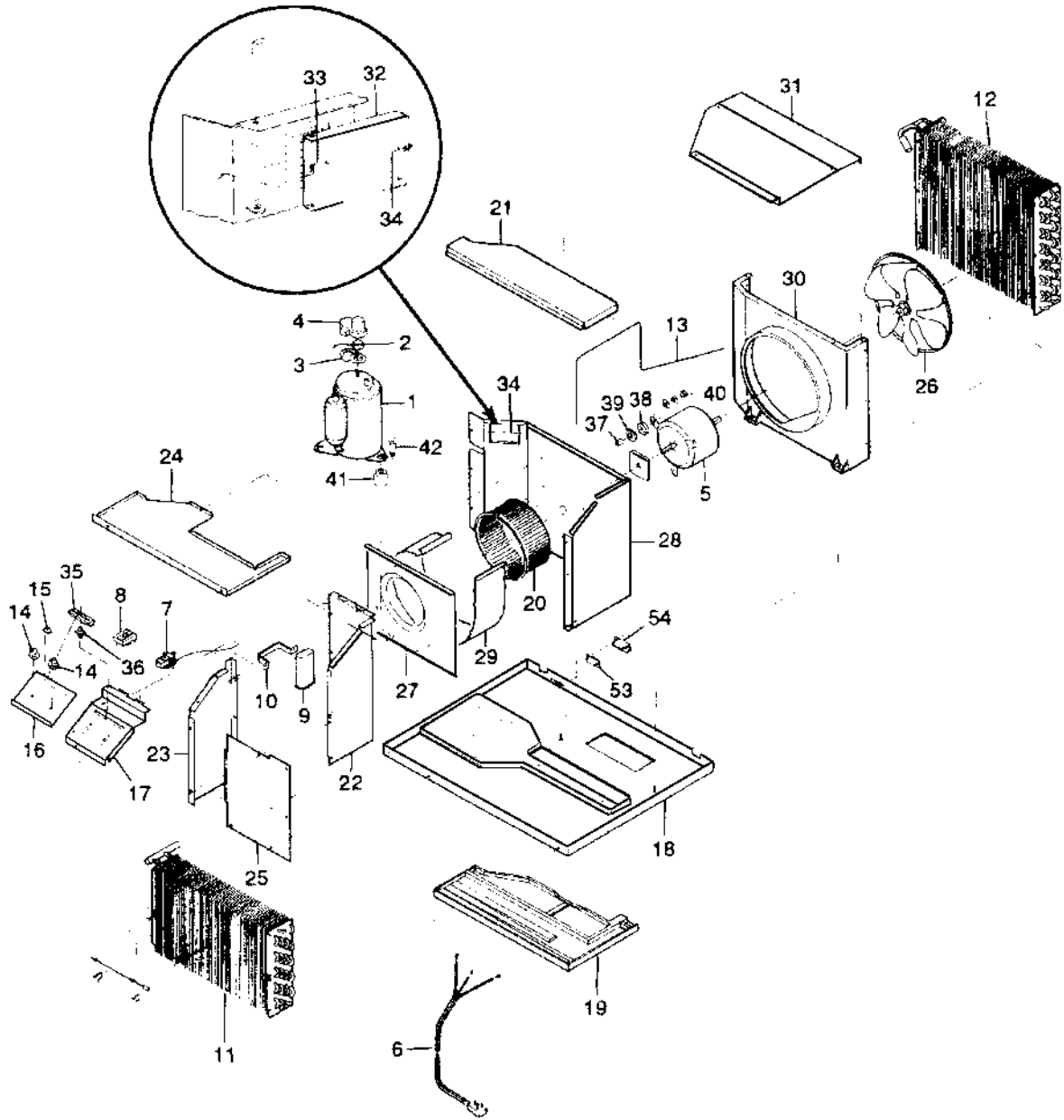

# "WS" SERIES DECORATIVE FRONT

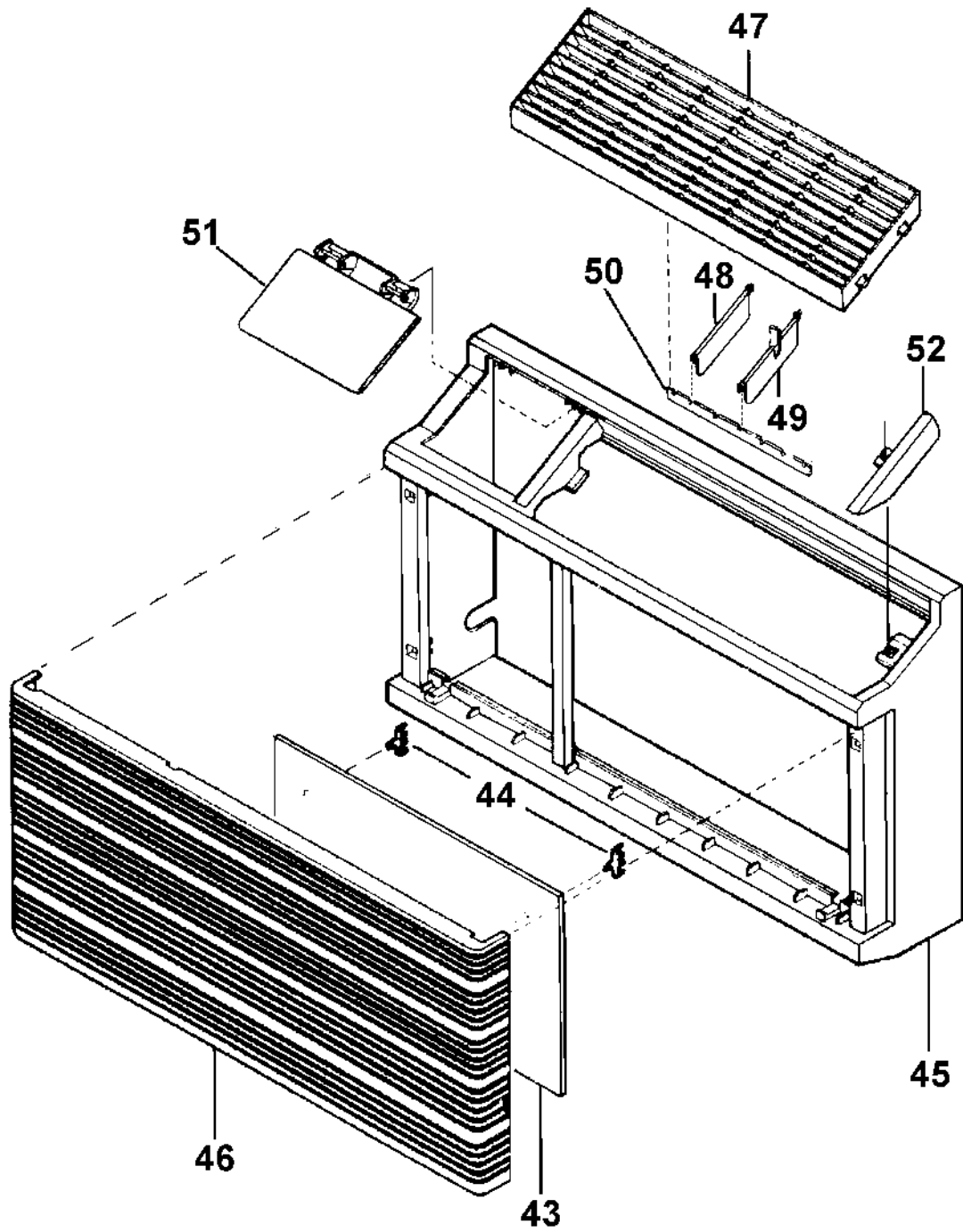

## "WS" SERIES PARTS LIST

REF.	PART NO.	DESCRIPTION	APPLICATION						
			W S 0 7 A 1 0 B	W S 1 0 A 1 0 B	W S 1 2 A 1 0 E	W S 1 2 1 1 0 E B	W S 0 9 A 3 0 E C	W S 1 2 A 3 0 E C	W S 1 5 A 3 0 B B
<b><u>ELECTRICAL PARTS</u></b>									
1	617-166-39	Compressor .....	1						
1	617-166-22	Compressor .....		1					
1	617-166-56	Compressor .....			1	1			
1	617-166-38	Compressor .....					1		
1	617-166-28	Compressor .....						1	
1	617-165-31	Compressor .....						1	
2	617-645-33	Overload, Compressor .....	1						
2	617-645-00	Overload, Compressor .....		1					
2	603-645-90	Overload, Compressor .....			1	1			
2	617-780-01	Overload, Compressor .....					1		
2	603-645-96	Overload, Compressor .....						1	
2	603-645-97	Overload, Compressor .....						1	
3	615-421-00	Gasket, Terminal .....	1	1	1	1	1	1	
4	615-422-00	Cover, Terminal .....	1	1	1	1	1	1	
5	610-714-53	Motor, Fan .....	1	1					
5	610-714-52	Motor, Fan .....			1	1			
5	610-714-54	Motor, Fan .....					1		
5	610-714-51	Motor, Fan .....						1	
6	605-000-60	Cord, Electric Supply .....		1	1	1			
6	605-000-61	Cord, Electric Supply .....					1		
6	605-000-62	Cord, Electric Supply .....					1	1	
7	618-225-03	Thermostat (Cool) .....	1	1	1	1	1	1	
*	617-151-00	Holder, Thermostat Bulb .....	1	1	1	1	1	1	
8	606-072-03	Switch, System (Rotary) .....	1	1	1	1	1	1	
9	610-805-54	Capacitor, Run .....	1						
9	610-805-35	Capacitor, Run .....		1	1	1			
9	610-805-62	Capacitor .....					1		
9	610-805-40	Capacitor .....						1	
10	618-207-01	Strap, Capacitor .....	1	1	1	1	1	1	
<b><u>REFRIGERATION SYSTEM COMPONENTS</u></b>									
11	616-002-21	Coil, Evaporator .....	1						
11	620-500-02	Coil, Evaporator .....		1			1		
11	620-500-00	Coil, Evaporator .....			1	1		1	
11	616-002-19	Coil, Evaporator .....						1	
12	618-503-09	Coil, Condenser .....	1						
12	620-502-02	Coil, Condenser .....		1			1		

\* Not Shown

## "WS" SERIES PARTS LIST

REF.	PART NO.	DESCRIPTION	APPLICATION						
			W S 0 7 A 1 0 B	W S 1 0 A 1 0 B	W S 1 2 A 1 0 E B	W S 1 2 A 1 0 E C	W S 0 9 A 3 0 E C	W S 1 2 A 3 0 E B	W S 1 5 A 3 0 B
<b><u>ELECTRICAL PARTS</u></b>									
	618-503-08	Coil, Condenser .....		1		1			
12	618-502-00	Coil, Condenser .....			1			1	1
*	603-081-01	Filter-Drier (Install Drier during Sealed System Repair) .....	1	1	1	1	1	1	1
13	03760513	†Capillary Tube .....	1						
13	03760547	†Capillary Tube .....		1		1			
13	03760520	†Capillary Tube .....			1		1		
13	03760550	†Capillary Tube .....							2
<b><u>CHASSIS PARTS</u></b>									
14	614-939-03	Knob, Control .....	2	2	2	2	2	2	2
15	616-389-00	Button, Slide (Exhaust) .....	1	1	1	1	1	1	1
16	617-501-01	Panel, Decorative Control .....	1	1	1	1	1	1	1
17	617-578-00	Panel, Control Mounting .....	1	1	1	1	1	1	1
18	616-062-01	Base Pan Assembly .....	1						
18	616-062-03	Base Pan Assembly .....		1	1	1	1	1	
19	616-026-00	Drain Pan .....	1	1	1	1	1	1	1
20	604-106-04	Wheel, Blower .....	1						
20	604-152-05	Wheel, Blower .....		1	1	1	1	1	
20	604-152-04	Wheel, Blower .....						1	
21	616-058-00	Cover, Bulkhead .....	1	1	1	1	1	1	1
22	616-054-04	Panel, Control Assembly .....	1	1	1	1	1	1	1
23	616-046-00	Panel, Left Side .....	1	1	1	1	1	1	1
24	616-056-00	Deck Assembly (Insulated) .....	1	1	1	1	1	1	1
25	616-101-01	Panel, Front .....	1	1	1	1	1	1	1
26	605-420-02	Fan Blade, Condenser .....	1	1	1	1	1	1	1
27	616-571-00	Front, Blower .....	1						
27	616-037-00	Front, Blower .....		1	1	1	1	1	1
28	616-051-00	Inner Wall Assembly .....	1	1	1	1	1	1	1
29	610-225-07	Wrapper, Blower .....	1	1	1	1	1	1	1
30	616-027-00	Shroud, Condenser .....	1	1	1	1	1	1	1
31	616-044-00	Cover, Shroud & Condenser Brace .....	1	1	1	1	1	1	1
32	613-583-01	Door, Exhaust Assembly .....	1	1	1	1	1	1	1
33	616-136-00	Spring, Door .....	1	1	1	1	1	1	1
34	613-584-01	Link, Exhaust Door .....	1	1	1	1	1	1	1
35	616-562-00	Channel, Exhaust Door .....	1	1	1	1	1	1	1
36	616-562-01	Slide, Exhaust Door .....	1	1	1	1	1	1	1
37	01336910	Sleeve, Fan Motor Mount .....	3	3	3	3	3	3	3
38	606-406-00	Retainer Cup – Fan Motor Mount .....	3	3	3	3	3	3	3
39	606-405-00	Grommet, Fan Motor Mount .....	3	3	3	3	3	3	3
40	910-030-00	Nut, Fan Motor Mount .....	3	3	3	3	3	3	3
41	610-289-00	Grommet, Compressor Mounting .....	3	3	3	3	3	3	3
42	914-004-00	Screw, Compressor Mounting .....	3	3	3	3	3	3	3
43	608-658-05	Filter, Air .....	1	1	1	1	1	1	1
44	608-659-00	Holder, Filter .....	2	2	2	2	2	2	2

\* Not Shown

## "WS" SERIES PARTS LIST

REF.	PART NO.	DESCRIPTION	APPLICATION						
			W S 0 7 A 1 0 B	W S 1 0 A 1 0 B	W S 1 2 A 1 0 E B	W S 1 2 A 1 0 E C	W S 0 9 A 3 0 E C	W S 1 2 A 3 0 E B	W S 1 5 A 3 0 B
<b>CHASSIS PARTS (Cont.)</b>									
*	616-070-01	Front, Decorative (Complete) .....	1	1	1	1	1	1	1
45	616-126-01	Frame, Hood .....	1	1	1	1	1	1	1
46	616-127-02	Grille (Intake) .....	1	1	1	1	1	1	1
47	616-128-00	Grille (Discharge) .....	1	1	1	1	1	1	1
48	616-129-00	Louver .....	12	12	12	12	12	12	12
49	616-129-01	Louver with Handle .....	2	2	2	2	2	2	2
50	616-130-00	Bar, Connector .....	2	2	2	2	2	2	2
51	616--131-00	Door, Control .....	1	1	1	1	1	1	1
52	616-132-00	End Cap, Discharge Grille .....	1	1	1	1	1	1	1
53	616-039-00	Gasket, Drain .....	1	1	1	1	1	1	1
54	616-040-00	Plate, Drain .....	1	1	1	1	1	1	1
*	608-460-14	Hardware Assembly (Screws) .....	1	1	1	1	1	1	1
*	616-306-06	Carton, Shipping .....	1	1	1	1	1	1	1
*	616-247-01	Support (Shipping Carton) .....	1	1	1	1	1	1	1
*	616-249-01	Carton (Shipping Insert) .....	1	1	1	1	1	1	1
*	616-246-04	Pad, Shipping .....	1	1	1	1	1	1	1
<b>OPTIONAL ACCESSORIES</b>									
*	AG88	Architectural Grille Kit .....	x	x	x	x	x	x	x
*	BAK	Baffle Adapter Kit (Use only with sleeves measuring 19¾" deep) .....	x	x	x	x	x	x	x
*	DK89	Optional Drain Kit .....	x	x	x	x	x	x	x
*	SB89	Subbase .....	x	x	x	x	x	x	x
*	IDK	Internal Drain Kit .....	x	x	x	x	x	x	x

\* Not Shown

# "WE" – "WY" SERIES CHASSIS PARTS

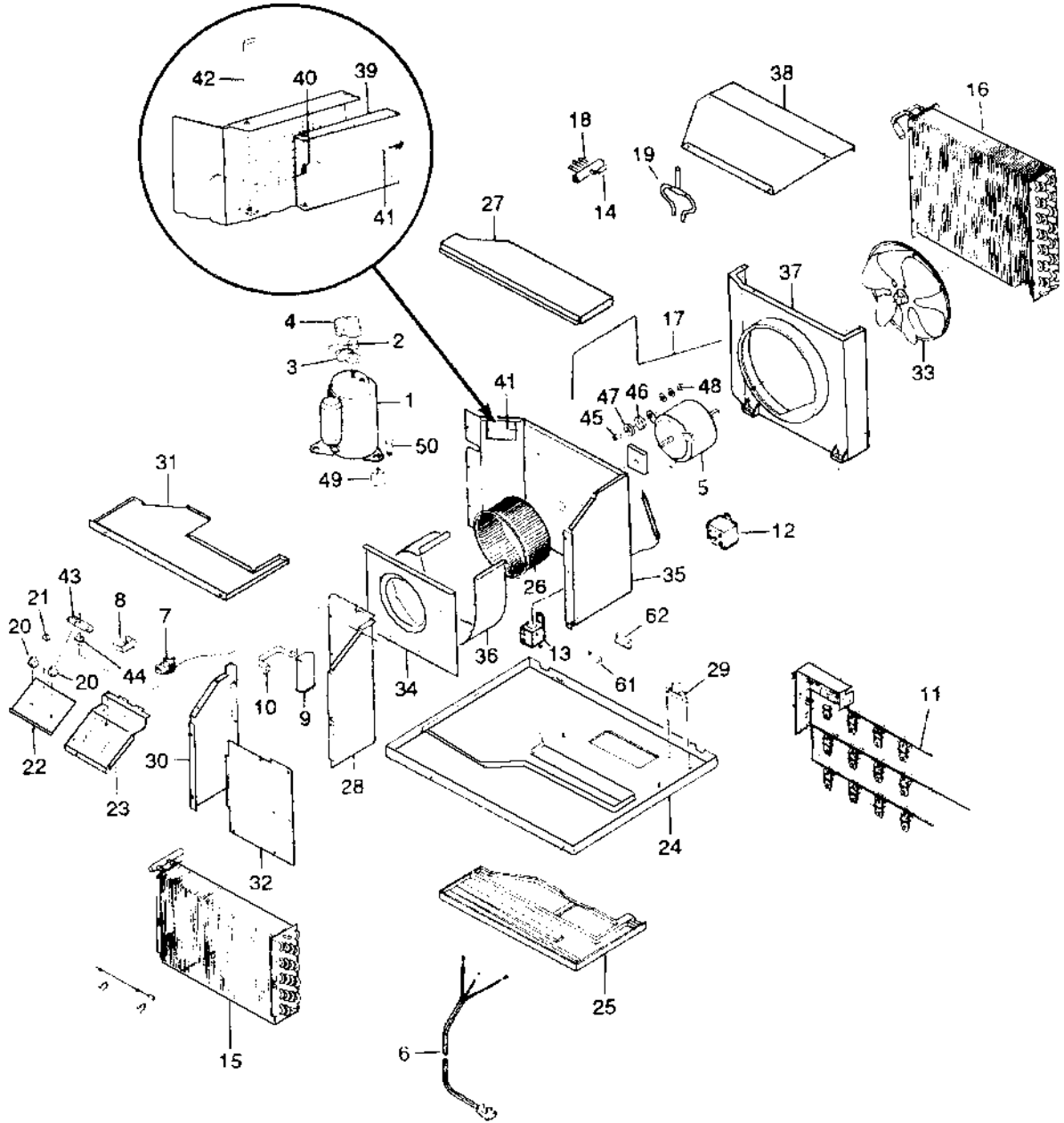

# "WE" – "WY" SERIES DECORATIVE FRONT

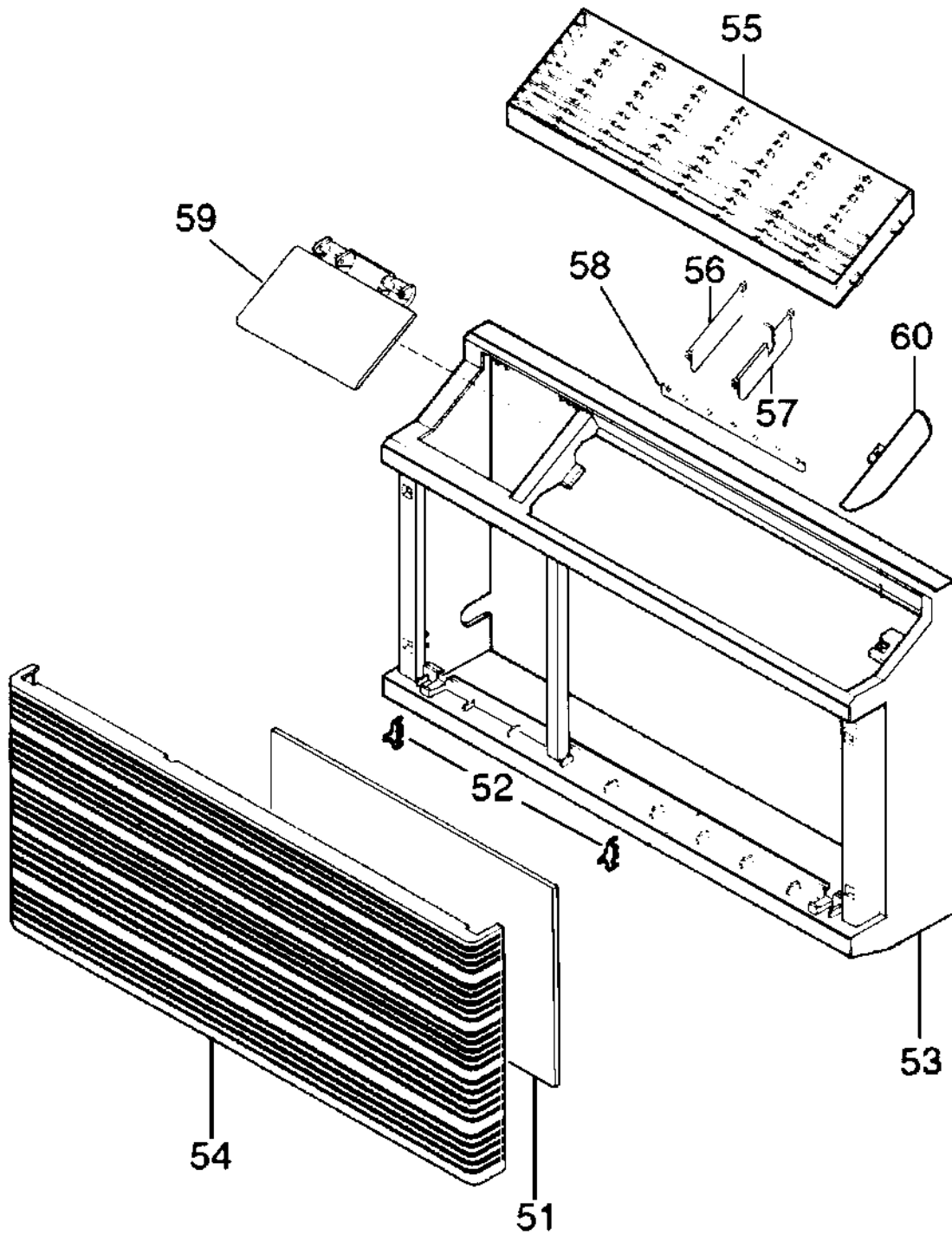

## "WE" - "WY" SERIES PARTS LIST

REF.	PART NO.	DESCRIPTION	APPLICATION				
			W E 0 9 A 3 3 E C	W E 1 2 A 3 3 E B	W E 1 5 A 3 3 B	W Y 0 9 A 3 3 F A	W Y 1 2 A 3 3 G A
<b><u>ELECTRICAL PARTS</u></b>							
1	617-166-38	Compressor, Tecumseh .....	1			1	
1	617-166-28	Compressor, Tecumseh .....		1			1
1	617-166-31	Compressor, Tecumseh .....			1		
2	617-645-35	Overload, Compressor .....	1			1	
2	617-645-21	Overload, Compressor .....		1			1
2	617-645-32	Overload, Compressor .....			1		
3	615-421-00	Gasket, Terminal .....	1	1	1	1	1
4	615-422-00	Cover, Terminal .....	1	1	1	1	1
5	610-714-54	Motor, Fan .....	1			1	
5	610-714-51	Motor, Fan .....		1	1		1
6	605-000-63	Cord, Electric Supply - 20 Amp., 250 Volt .....	1	1	1	1	1
7	250-433-60	Thermostat (Heat & Cool) .....	1	1	1	1	1
*	617-151-00	Holder, Thermostat Bulb .....	1	1	1	1	1
8	606-072-04	Switch, System (Rotary) .....	1	1	1	1	1
9	610-805-40	Capacitor, Run .....	1			1	
9	610-805-65	Capacitor, Run .....		1	1		1
10	618-207-01	Strap, Capacitor .....	1	1	1	1	1
11	615-808-02	Heater - 3.4 KW, 230 V .....	1	1	1	1	1
*	615-963-00	Fuse Link .....	1	1	1	1	1
*	615-962-00	Limit Switch .....	1	1	1	1	1
13	613-503-13	Defrost Control, Thermostat .....				1	1
*	603-018-03	Clip, Defrost Bulb .....				1	1
14	210-586-43	Solenoid, Reversing Valve - 230 Volt .....				1	1
*	618-624-08	Harness wire (solenoid) .....				1	1
*	618-213-00	Harness wire (compressor) .....				1	1
<b><u>REFRIGERATION SYSTEM COMPONENTS</u></b>							
	616-002-18	Coil, Evaporator .....				1	
15	620-500-02	Coil, Evaporator .....	1			1	
15	616-002-19	Coil, Evaporator .....		1			1
15	620-500-00	Coil, Evaporator .....			1		
16	620-502-02	Coil, Condenser .....	1				
16	618-503-08	Coil, Condenser .....		1			
16	620-502-00	Coil, Condenser .....			1		
16	616-005-12	Coil, Condenser .....				1	
16	616-005-13	Coil, Condenser .....					1
*	614-813-00	Filter-Drier (Install Drier during sealed system repair) .....	1	1	1		
*	618-282-00	Suction Line Drier (Install during sealed system repair) .....				1	1
17	03760547	† Capillary Tube .....	1				
17	03760520	† Capillary Tube .....		1			
17	03760550	† Capillary Tube .....			2		
17	03760557	† Capillary Tube (Cooling) .....				1	
17	619-860-00	† Filter Check Valve Capillary Tub Assy. ....				1	
17	619-119-02	† Filter Check Valve Capillary Tub Assy. ....					1

## "WE" - "WY" SERIES PARTS LIST

REF.	PART NO.	DESCRIPTION	APPLICATION				
			WE09A33EC	WE12A33EB	WE13A33B	WY09A33FA	WY12A33GA
<b>REFRIGERATION SYSTEM COMPONENTS (Cont)</b>							
17	037-605-58	Capillary Tube (Cooling –.042 I.D. x 35" Long .....					1
18	619-089-01	4-Way Valve, & Cap Tube Assy .....					1
19	619-089-02	4-Way Valve, & Cap Tube Assy .....				1	
<b>CHASSIS PARTS</b>							
20	614-939-03	Knob, Control .....	1	1	1	1	1
21	616-389-00	Button, Slide (Exhaust) .....	1	1	1	1	1
22	617-502-01	Panel, Decorative Control .....	1	1	1	1	1
23	617-578-00	Panel, Control Mounting .....	1	1	1	1	1
24	616-062-05	Base Pan Assembly .....	1	1	1	1	1
25	616-026-00	Drain Pan .....	1	1	1	1	1
26	604-152-03	Wheel, Blower .....	1	1		1	1
26	604-152-04	Wheel, Blower .....			1		
27	616-058-00	Cover, Bulkhead .....	1	1	1	1	1
28	616-054-04	Panel, Control Assembly .....	1	1	1		
28	616-054-05	Panel, Control Assembly .....				1	1
29	601-799-00	Bellows, Drain Valve .....	1	1	1	1	1
30	616-046-00	Panel, Left Side .....	1	1	1	1	1
31	616-056-00	Deck Assembly (Insulated) .....	1	1	1	1	1
32	616-101-00	Panel, Front .....	1	1	1	1	1
33	605-420-02	Fan Blade, Condenser .....	1	1	1	1	1
34	616-124-01	Front, Blower .....	1	1	1	1	1
35	616-051-01	Inner Wall Assembly .....	1	1	1	1	1
36	610-225-07	Wrapper, Blower .....	1	1	1	1	1
37	616-027-00	Shroud, Condenser .....	1	1	1	1	1
38	616-044-00	Cover, Shroud & Condenser Brace .....	1	1	1	1	1
39	613-583-01	Door, Exhaust Assembly .....	1	1	1	1	1
40	616-136-00	Spring, Door .....	1	1	1	1	1
41	613-584-01	Link, Exhaust Door .....	1	1	1	1	1
42	616-104-00	Hinge Pin, Exhaust Door .....	1	1	1	1	1
43	616-562-00	Channel, Exhaust Door .....	1	1	1	1	1
44	616-562-01	Slide, Exhaust Door .....	1	1	1	1	1
45	01336910	Sleeve, Fan Motor Mount .....	3	3	3	3	3
46	606-406-00	Retainer Cup – Fan Motor Mount .....	3	3	3	3	3
47	606-405-00	Grommet, Fan Motor Mount .....	3	3	3	3	3
48	01237650	Nut, Fan Motor Mount .....	3	3	3	3	3
49	610-289-00	Grommet, Compressor Mounting .....	3	3	3	3	3
50	914-004-00	Screw, Compressor Mounting .....	3	3	3	3	3
51	608-658-05	Filter, Air .....	1	1	1	1	1
52	608-659-00	Holder, Filter .....	2	2	2	2	2
*	616-070-01	Front, Decorative (Complete) .....	1	1	1	1	1
53	616-126-01	Frame, Hood .....	1	1	1	1	1

## "WE" - "WY" SERIES PARTS LIST

REF.	PART NO.	DESCRIPTION	APPLICATION				
			W E 0 9 A 3 3 E C	W E 1 2 A 3 3 E B	W E 1 5 A 3 3 B	W Y 0 9 A 3 3 F A	W Y 1 2 A 3 3 G A
<b>CHASSIS PARTS, (Cont.)</b>							
54	616-127-02	Grille, Intake .....	1	1	1	1	1
55	616-128-00	Grille, Discharge .....	1	1	1	1	1
56	616-129-00	Louver .....	12	12	12	12	12
57	616-129-01	Louver with Handle .....	2	2	2	2	2
58	616-130-00	Bar, Connector .....	2	2	2	2	2
59	616-131-00	Door, Control .....	1	1	1	1	1
60	616-132-00	End Cap, Discharge Grille .....	1	1	1	1	1
61	616-039-00	Gasket, Drain .....	1	1	1	1	1
62	616-040-00	Plate, Drain .....	1	1	1	1	1
*	608-460-14	Hardware Assembly (Screws) .....	1	1	1	1	1
*	616-306-06	Carton, Shipping .....	1	1	1	1	1
*	616-247-01	Support (Shipping Carton) .....	1	1	1	1	1
*	616-249-01	Carton, Shipping Insert .....	1	1	1	1	1
*	616-246-04	Pad, Shipping .....	1	1	1	1	1
<b>OPTIONAL ACCESSORIES</b>							
*	AG88	Architectural Grille Kit .....	x	x	x	x	x
*	BAK	Baffle Adapter Kit (use only with sleeves measuring 19¾" deep) .....	x	x	x	x	x
*	DK89	Optional Drain Kit .....	x	x	x	x	x
*	SB89	Subbase .....	x	x	x	x	x
*	IDK	Internal Drain Kit .....	x	x	x	x	x

\* Not Shown

## "WS" – "WE" – "WY" SERIES CHASSIS PARTS

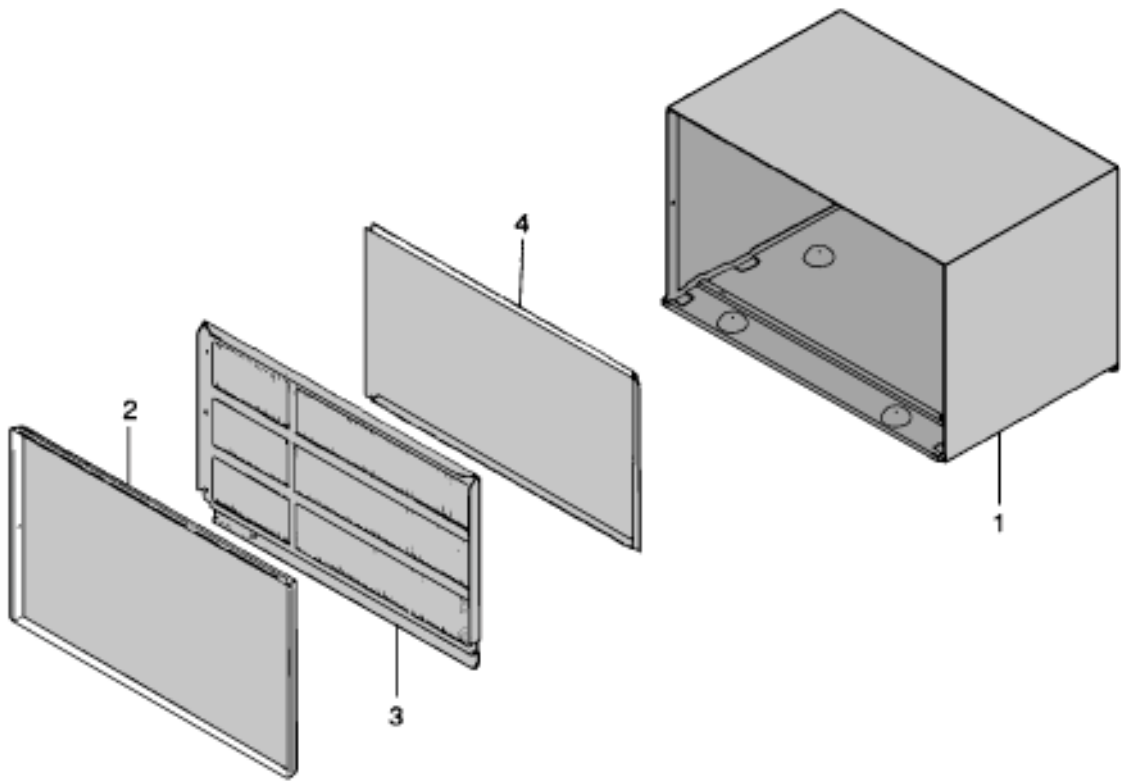

## "WS" - "WE" - "WY" SERIES SLEEVE PARTS LIST

REF.	PART NO.	DESCRIPTION	APPLICATION									
			W S 0 7 A 1 0 B	W S 1 0 A 1 0 B	W S 1 2 A 1 0 B	W S 0 9 A 3 0 C	W S 1 2 A 3 0 B	W S 1 5 A 3 0 B	W E 0 9 A 3 3 C	W E 1 2 A 3 3 B	W E 1 5 A 3 3 A	W Y 0 9 A 3 3 A
<b>CHASSIS PARTS, (Cont.)</b>												
1	616-036-01	Sleeve Assembly .....	1	1	1	1	1	1	1	1	1	1
*	608-460-08	Plastic Bag Assembly .....	1	1	1	1	1	1	1	1	1	1
2	616-032-00	Panel, Weather Inner .....	1	1	1	1	1	1	1	1	1	1
*	906-011-00	Screw, #8B x 3/8" .....	2	2	2	2	2	2	2	2	2	2
3	616-030-01	Grille, Louvered .....	1	1	1	1	1	1	1	1	1	1
*	604-058-04	Friedrich Script .....	1	1	1	1	1	1	1	1	1	1
*	906-047-01	Screw, #8A x 3/8" .....	5	5	5	5	5	5	5	5	5	5
5	616-033-01	Panel, Weather Outer .....	1	1	1	1	1	1	1	1	1	1
*	616-078-00	Label, Friedrich .....	1	1	1	1	1	1	1	1	1	1
*	616-084-01	Carton, Shipping .....	1	1	1	1	1	1	1	1	1	1

\* Not Shown

**Use Factory Certified Parts.**



**FRIEDRICH AIR CONDITIONING CO.**

Post Office Box 1540 · San Antonio, Texas 78295-1540  
4200 N. Pan Am Expressway · San Antonio, Texas 78218-5212  
(210) 357-4400 · FAX (210) 357-4480  
[www.friedrich.com](http://www.friedrich.com)

Printed in the U.S.A.

**WM0100 (5-03)**