



FRONT AVENUE

MODEL 463242304 PRODUCT GUIDE

THIS GRILL IS FOR OUTDOOR USE ONLY

⚠ CAUTION:

Read and follow all safety statements, assembly instructions, and use and care directions before attempting to assemble and cook.

INSTALLER/ASSEMBLER:

Leave these instructions with consumer.

CONSUMER:

Keep this manual for future reference.

⚠ WARNING:

Failure to follow all manufacturer's instructions could result in serious personal injury and/or property damage.

⚠ CAUTION:

Some parts may contain sharp edges - especially as noted in the manual! Wear protective gloves if necessary.

If you have any questions or need assistance during assembly, please call 1-800-241-7548.





WARNING



FOR YOUR SAFETY

1. Do not store or use gasoline or other flammable vapors and liquids in the vicinity of this or any other appliance.
2. An LP tank not connected for use shall not be stored in the vicinity of this or any other appliance.

FOR YOUR SAFETY

If you smell gas:

1. Shut off gas to the appliance.
2. Extinguish any open flame.
3. Open lid.
4. If odor continues, immediately call your gas supplier or your fire department.

Call Grill Service Center For Help And Parts

- If you need help or warranty parts call 1-800-241-7548 U.S. or 1-800-387-6057 CANADA.
Business hours: Open 24 hours – Seven days a week.
- To order non-warranty replacement parts or accessories (*grill cover, cleaners, paint*) call 1-800-993-2677 or send a FAX to 1-706-565-2121.

IMPORTANT: Fill out the product record information below.

Model Number _____

Serial Number _____
See rating label on grill for serial number.

Date Purchased _____



CAUTION



For residential use only. Do not use for commercial cooking.



WARNING



Combustion by-products produced when using this product contain chemicals known to the State of California to cause cancer, birth defects, and other reproductive harm.

Installation Safety Precautions

- Use grill only with LP (propane) gas and the regulator/valve assembly supplied.
- Grill installation must conform with local codes, or in their absence with **National Fuel Gas Code, NFPA 54 / ANSI Z223.1** or **CAN/CGA-B149.2 Propane Installation Code**. Handling and storage of LP cylinders must conform to LP Gas Code **NFPA/ANSI 58**. Grill is not for use in or on recreational vehicles and/or boats.
- All electrical accessories (such as rotisserie) must be electrically grounded in accordance with local codes, or **National Electrical Code, ANSI / NFPA 70** or **Canadian Electrical Code, CSA C22.1**. Keep any electrical cords and/or fuel supply hoses away from any hot surfaces.
- This grill is safety certified for use in the United States or Canada only. Do not modify for use in any other location. Modification will result in a safety hazard.

Safety Symbols

The symbols and boxes shown below explain what each heading means. Read and follow all of the messages found throughout the manual.



DANGER



DANGER: Indicates an imminently hazardous situation which, if not avoided, will result in death or serious injury.



WARNING



WARNING: Be alert to the possibility of serious bodily injury if the instructions are not followed. Be sure to read and carefully follow all of the messages.



CAUTION



CAUTION: Indicates a potentially hazardous situation which, if not avoided, may result in minor or moderate injury.

TABLE OF CONTENTS

For Your Safety	2
Grill Service Center.	2
Product Record Information	2
Installation Safety Precautions	2
Safety Symbols	2
Warranty	3
Parts List	4
Parts Diagram	5
Assembly	6-13
Use and Care	14-23

WARRANTY

Manufacturer warrants to the original consumer-purchaser that this product shall be free from defects in workmanship and materials under normal and reasonable use and correct assembly (if assembled by consumer-purchaser), from date of purchase.

Cast iron burners - For as long as you own your grill.
Stainless steel and die cast parts - 99 years
Electronic ignition - 10 years
Remaining parts - 2 years

Manufacturer will, at its option, refinish or replace any product or part found to be defective during the warranty period. Manufacturer will require you to return the part(s) claimed to be defective, for its inspection, freight or postage prepaid.

If you wish to obtain performance of any obligation under this limited warranty, you should write to:

Consumer Warranty / P.O. Box 1240
Columbus, GA 31902-1240

Manufacturer may require reasonable proof of purchase and we suggest you keep your receipt. In the state of California only, if refinishing or replacement of the product is not commercially practicable, the retailer selling this product or Manufacturer will refund the purchase price paid for the product, less the amount directly attributable to use by the original consumer-purchaser prior to discovery of the nonconformity. In addition, in the state of California only, you may take the product to the retail establishment from which it was purchased or to any retail establishment selling this product in order to obtain performance under this warranty.

This warranty does not include the cost on any inconvenience or property damage due to failure of the product and does not cover damage due to misuse, abuse, accident, damage arising out of transportation of the product, or damage incurred through commercial use of the product. This express warranty is the sole warranty given by the manufacturer and is in lieu of all other warranties, express or implied, including implied warranty of merchantability or fitness for a particular purpose. Neither Manufacturer dealers nor the retail establishment selling this product has any authority to make any warranties or to promise remedies in addition to or inconsistent with those stated above. Manufacturer's maximum liability, in any event, shall not exceed the purchase price of the product paid by the original consumer-purchaser. Some states do not allow the exclusion or limitation of incidental or consequential damages. So the above limitations or exclusions may not apply to you. This warranty gives you specific legal rights and may also have other rights which vary from state to state.

PARTS LIST – Model No. 463242304

<u>Key</u>	<u>Qty</u>	<u>Description</u>	<u>Part #</u>	<u>Key</u>	<u>Qty</u>	<u>Description</u>	<u>Part #</u>
	1	Grill Lid Assembly	80000900		1	Cart Assembly	80000593
A	1	Lid.	80000901	BB	1	Cart Side Panel Left	80000594
B	1	Lid Handle	80000559	CC	1	Cart Side Panel Right.	80000560
C	1	Thermometer	80000096	DD	1	Cart Back Panel	80000567
D	1	Thermometer Bezel	80000097	EE	4	Caster Socket.	80000377
E	1	Logo Plate	80001212	FF	1	Bottom Shelf.	80000565
	1	Grill Bottom Assembly	80000860	GG	2	Bottom Shelf Slide Tracks	80000569
F	1	Grill Bottom Frame	80000861	HH	1	Sway Brace	80001230
G	3	Main Burner	80000023		1	Rotisserie Motor and Spit Assembly 80001326	
H	1	Burner Brace/Carryover	80001210	II	1	Spit Rod	80001327
I	1	Manifold Heat Shield	80000882	JJ	1	Spit Handle.	80001328
J	1	Ignitor System Assembly	80001219	KK	1	Collar	80001329
K	1	Control Panel	80001220	LL	2	Fork	80001330
L	5	Control Knob	80000825	MM	1	Rotisserie Motor.	80001331
M	5	Control Knob Bezel	80000034	NN	1	Rotisserie Mounting Bracket, Right . . .	80001332
N	1	Smoker Tray.	80000886	OO	1	Rotisserie Mounting Bracket, Left	80001333
O	1	Manifold/Hose/Regulator Assembly . . .	80000877				
P	1	Rotisserie Assembly.	80000871	PP	1	Door Assembly - Left	80000572
Q	1	Rotisserie Electrode	80000885	QQ	1	Door Assembly - Right	80000576
R	4	Rotisserie Bracket	80001223	RR	1	Door Brace	80001238
	1	Sideburner Shelf Assembly	80000535	SS	1	Condiment Basket, Right	80000267
S	1	Sideburner Frame	80001224	TT	1	Condiment Basket, Left	80000266
T	1	Sideburner Lid	80000539	UU	2	Locking Caster	80000268
U	1	Sideburner Pan	80000051	VV	2	Fixed Caster.	80000269
V	1	Sideburner Electrode	80000055	WW	1	Grease Tray	80000582
W	1	Sideburner Control Panel.	80001340	XX	1	Grease Receptacle.	80000834
X	2	Towel Bar	80001245	YY	1	SwingAway Warming Rack	80000398
Y	1	Sideburner Assembly	80001233	ZZ	1	Cooking Grate Set	80000399
	1	Side Shelf Assembly	80000530	AAA	1	Sideburner Grate	80000282
Z	1	Side Shelf.	80000531	BBB	1	Match-Lighting Stick.	80000274
AA	1	Side Shelf Panel.	80001341	CCC	3	Flametamers	80000947
				EEE	1	Sideburner Valve Clip.	80000058
				FFF	1	AA Battery	80000284
					1	Hardware Pack.	80001241
					1	Product Guide	80001153

ASSEMBLY – Model No. 463242304

- 1 Place sideburner shelf over left cart legs. Lip of shelf should fit between grill bottom and leg brace. (It may be necessary to slightly loosen the two screws from inside the grill bottom, and tighten them again once shelf is attached.) Secure shelf brackets to cart legs using two 1/4-20x1/2" screws (FFF), 7mm lock washers (GGG), and 7mm flat washers (HHH) on each bracket. Repeat procedure to install side shelf on right side of grill.

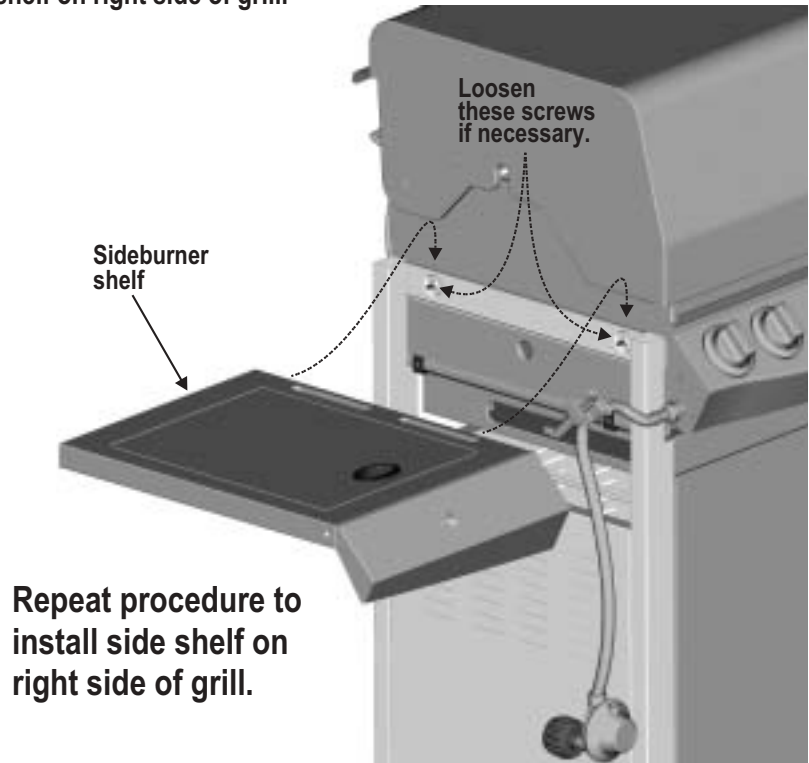
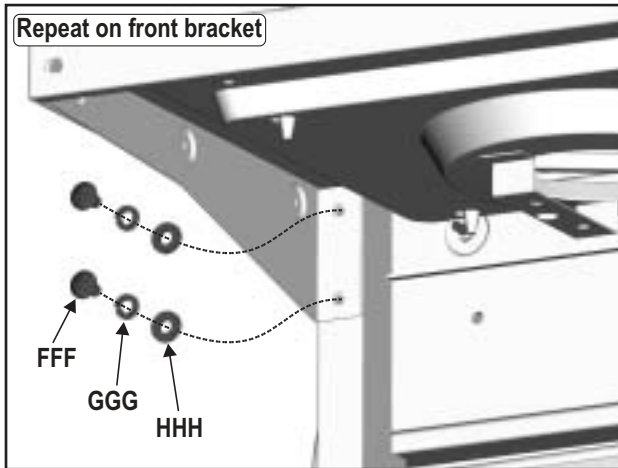

- 2 Remove the two screws (M4x10mm) and washers (4mm) from the sideburner valve bracket. Place sideburner valve under front of sideburner control panel so that valve stem comes through large hole. Place sideburner bezel over valve stem. Secure bezel to panel and valve bracket using the two screws and washers you removed from the valve bracket. Press control knob onto valve stem. Using a small slotted screwdriver, tighten the control knob set screw through the hole at the bottom edge of the knob.

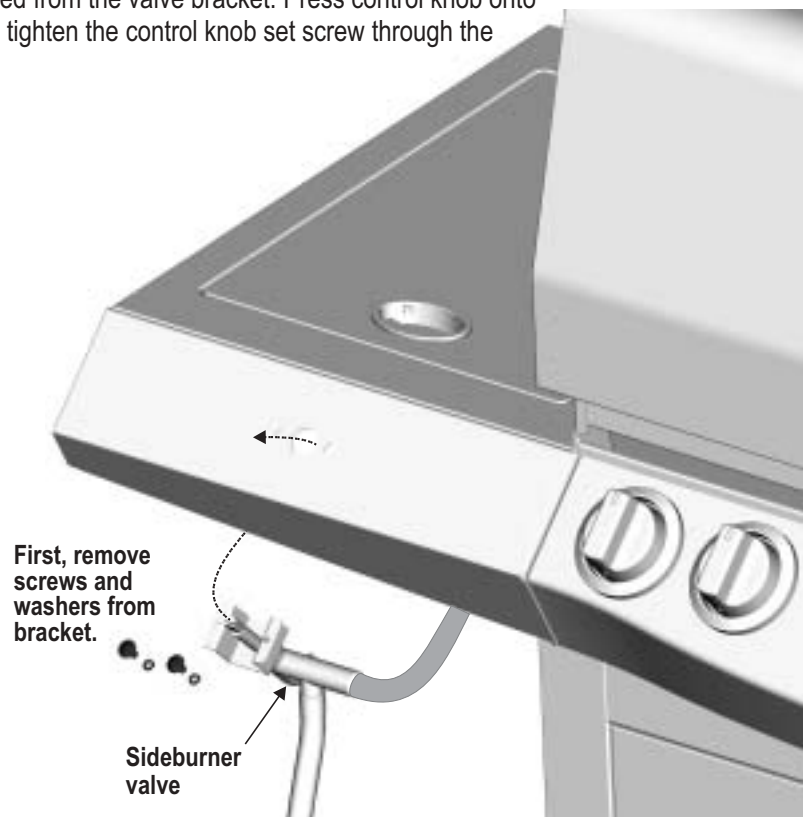
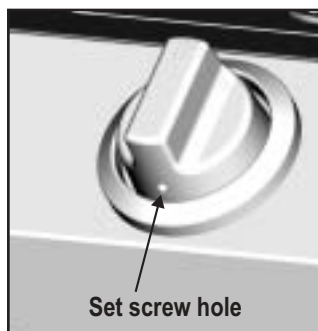
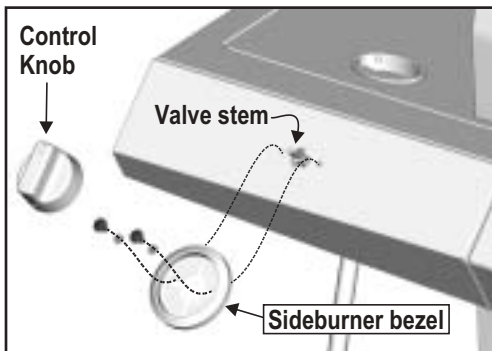

3

Insert sideburner into shelf, placing end of burner over sideburner valve. Valve should be in center hole of burner tube. Make sure pin on bottom of burner is in center hole in shelf bracket. Secure burner to bracket with two #10-24x3/8" screws (III), 5mm lock washers (JJJ), and 5mm flat washers (KKK). See illustration below for correct burner-to-valve engagement.

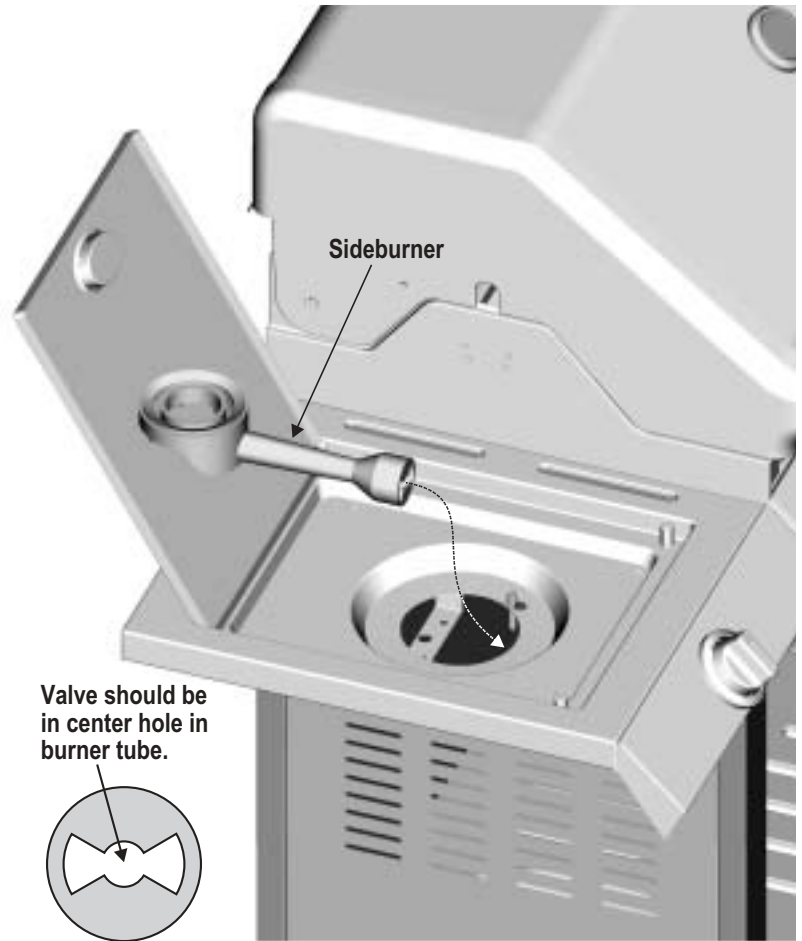
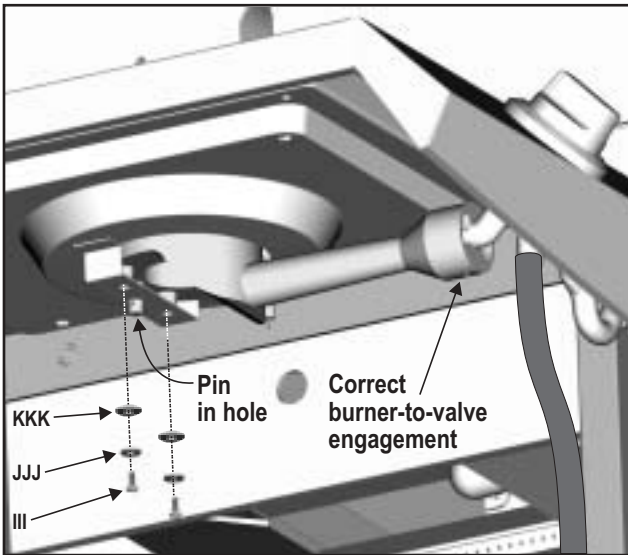

4

Insert valve clip into small hole in bottom of burner, then snap other end of clip over sideburner valve. Beneath sideburner shelf, attach sideburner ignitor wire to electrode. Place brass top on sideburner, then place sideburner grate onto shelf.

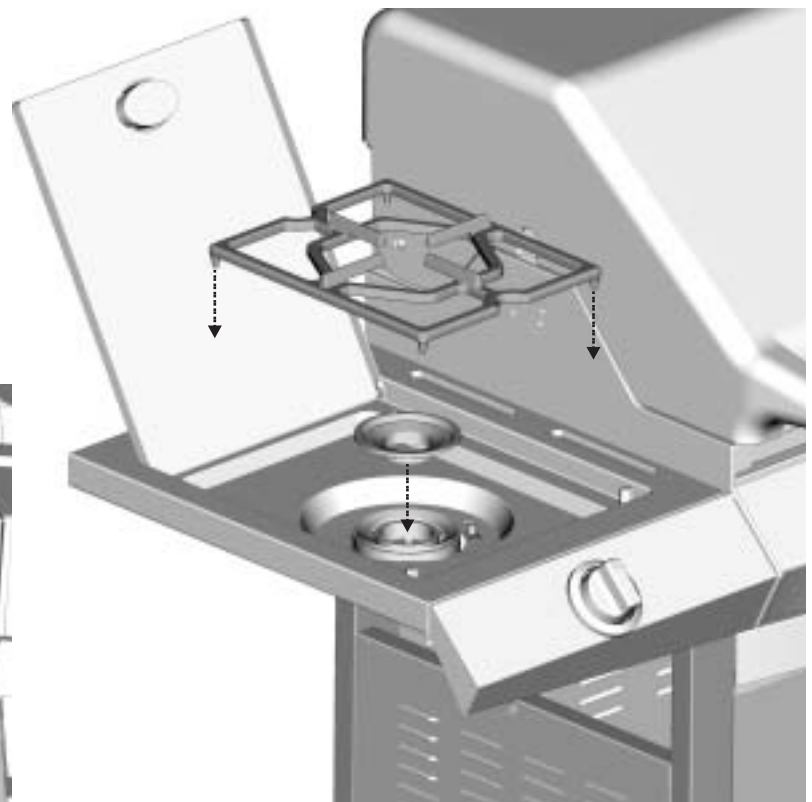
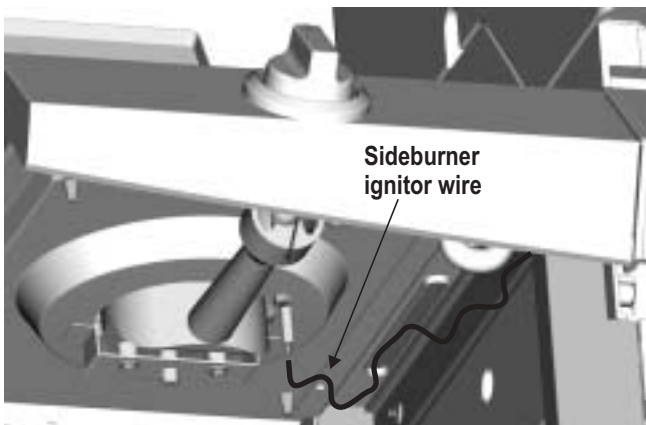
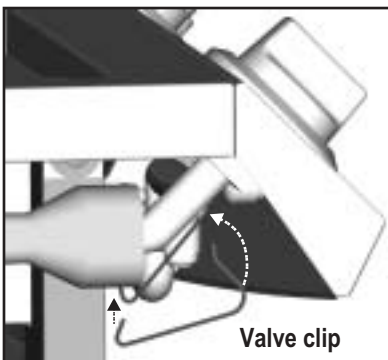

5

Open lid. Remove screws and washers attached to handle. Use these screws and washers to attach handle to lid.

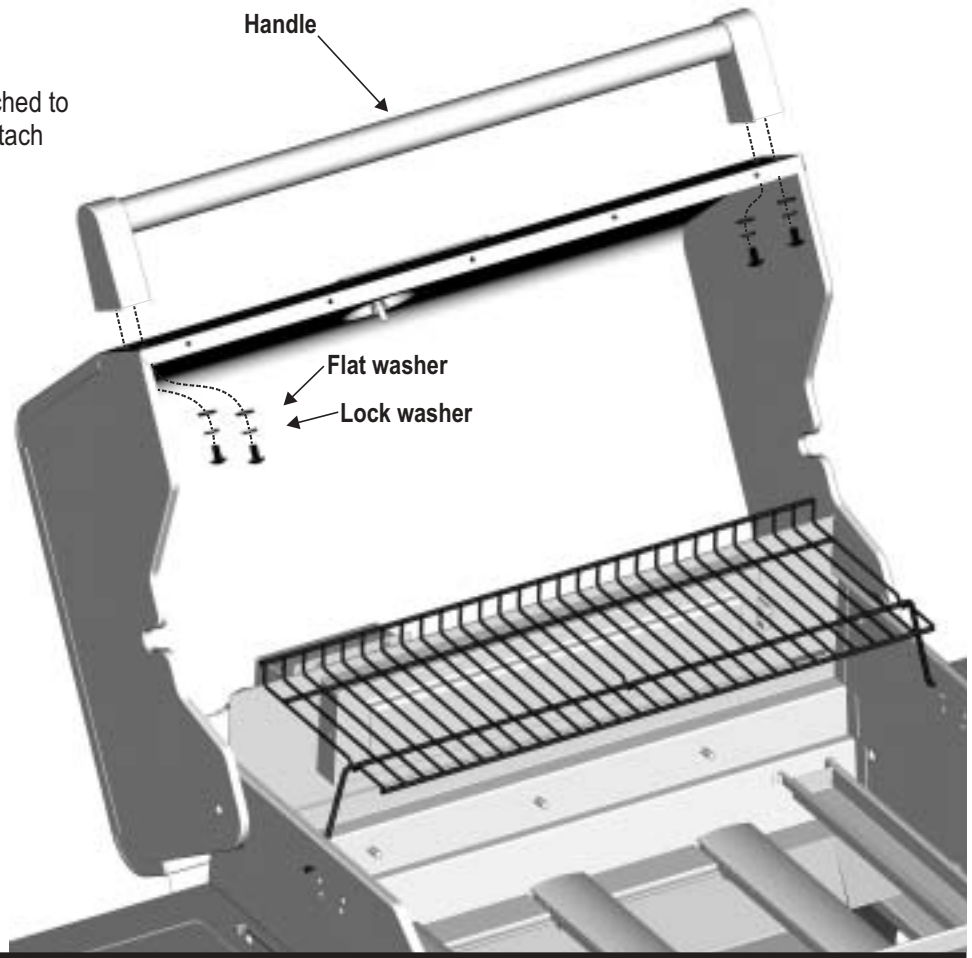

6

Remove screws and washers from ends of towel bars. Insert screws from beneath shelf, through shelf holes and into ends of towel bar. **Repeat procedure on sideburner shelf.** Attach the rotisserie motor bracket to the right side of the grill bottom using two #10-24x3/8" screws (III), 5mm lock washers (JJJ), and 5mm flat washers (KKK) from the outside and two #10-24 hex nuts (LLL) on the inside of the grill bottom. **Attach the spit rod bracket to the left side of the grill bottom in the same manner.**

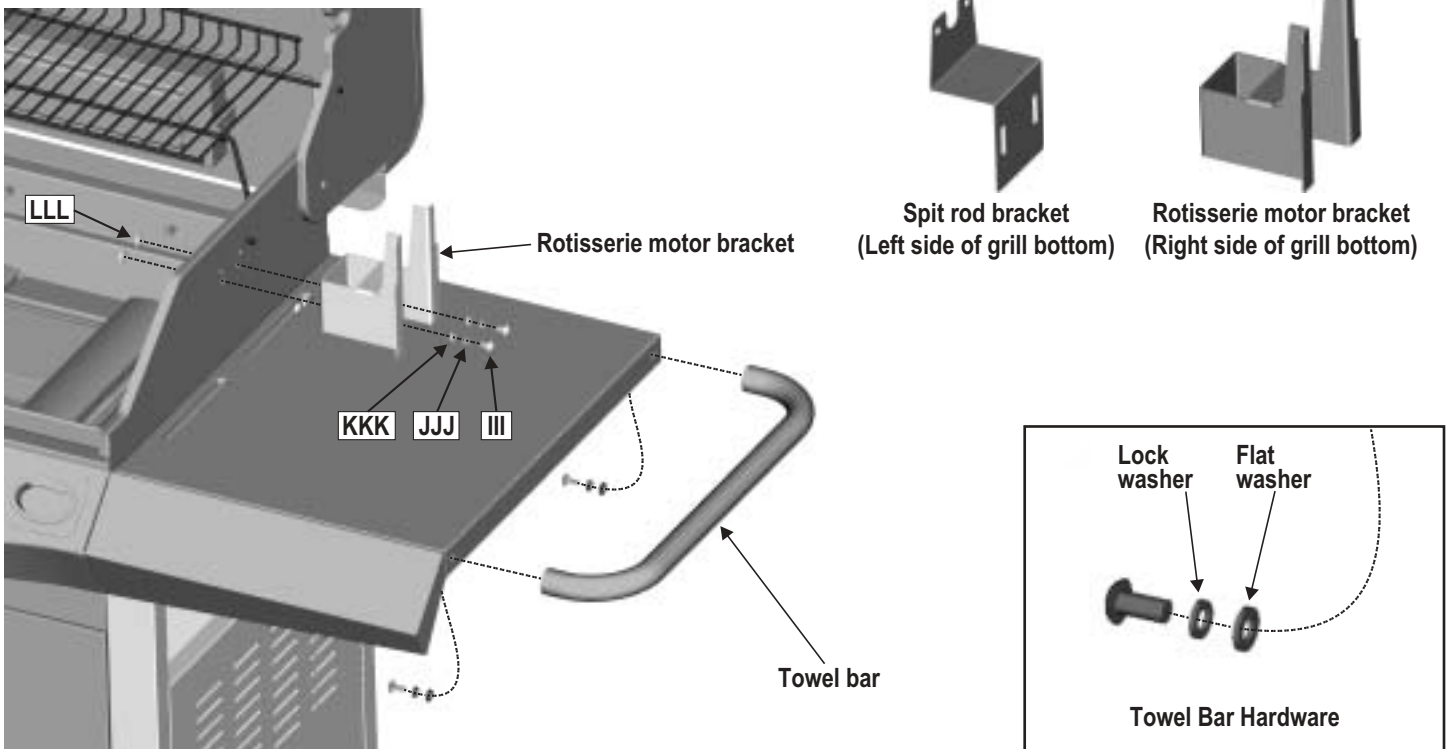

7 Place flametamers (3) over burners by inserting tabs into slots in front of firebox. Opposite ends of flametamers rest on pins in back of firebox.

NOTE: SwingAway not shown for clarity.

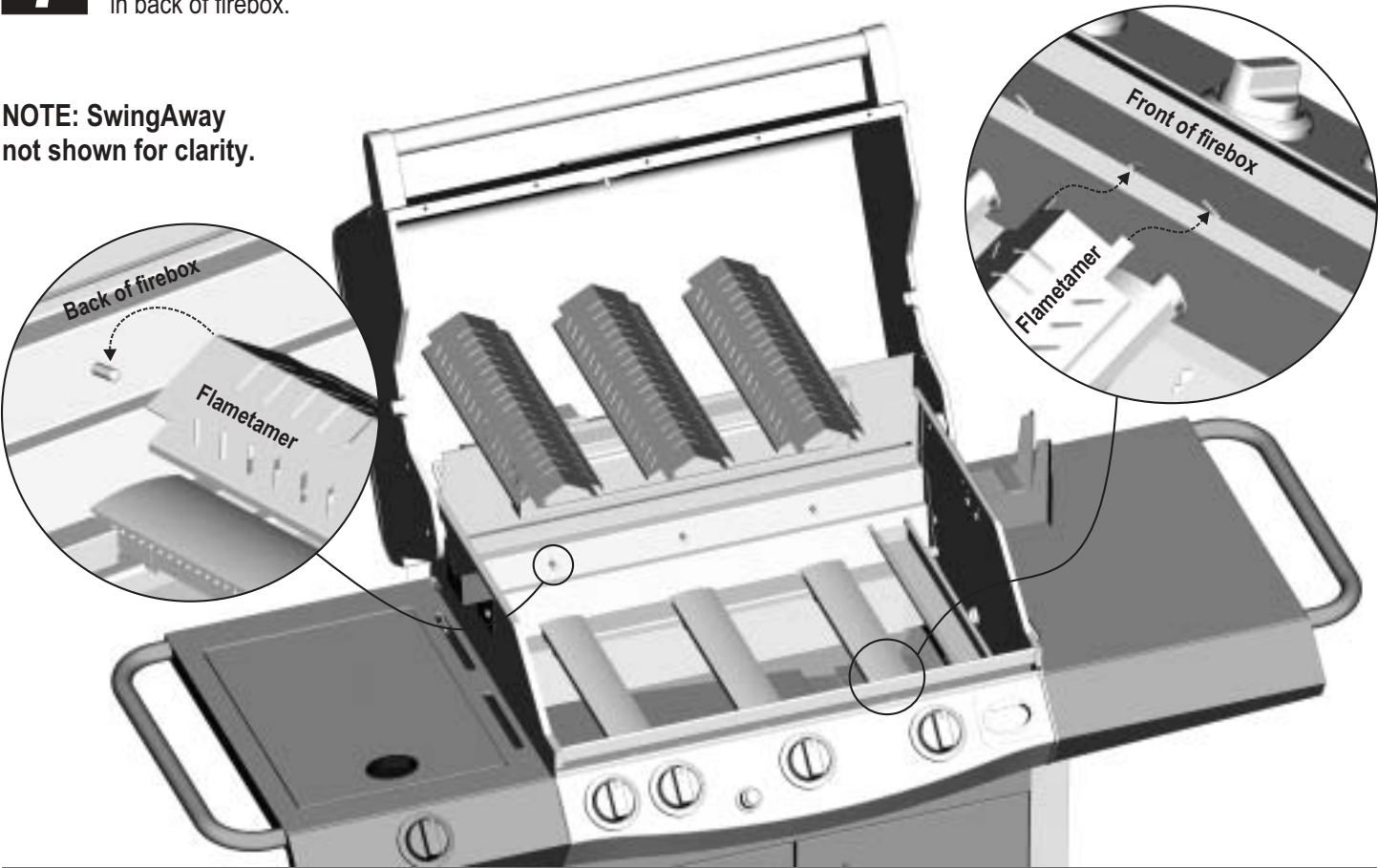

8

Place cooking grates into grill bottom. Grate wires running front to back should be toward the top side of square tubes at each end.

NOTE: SwingAway not shown for clarity.

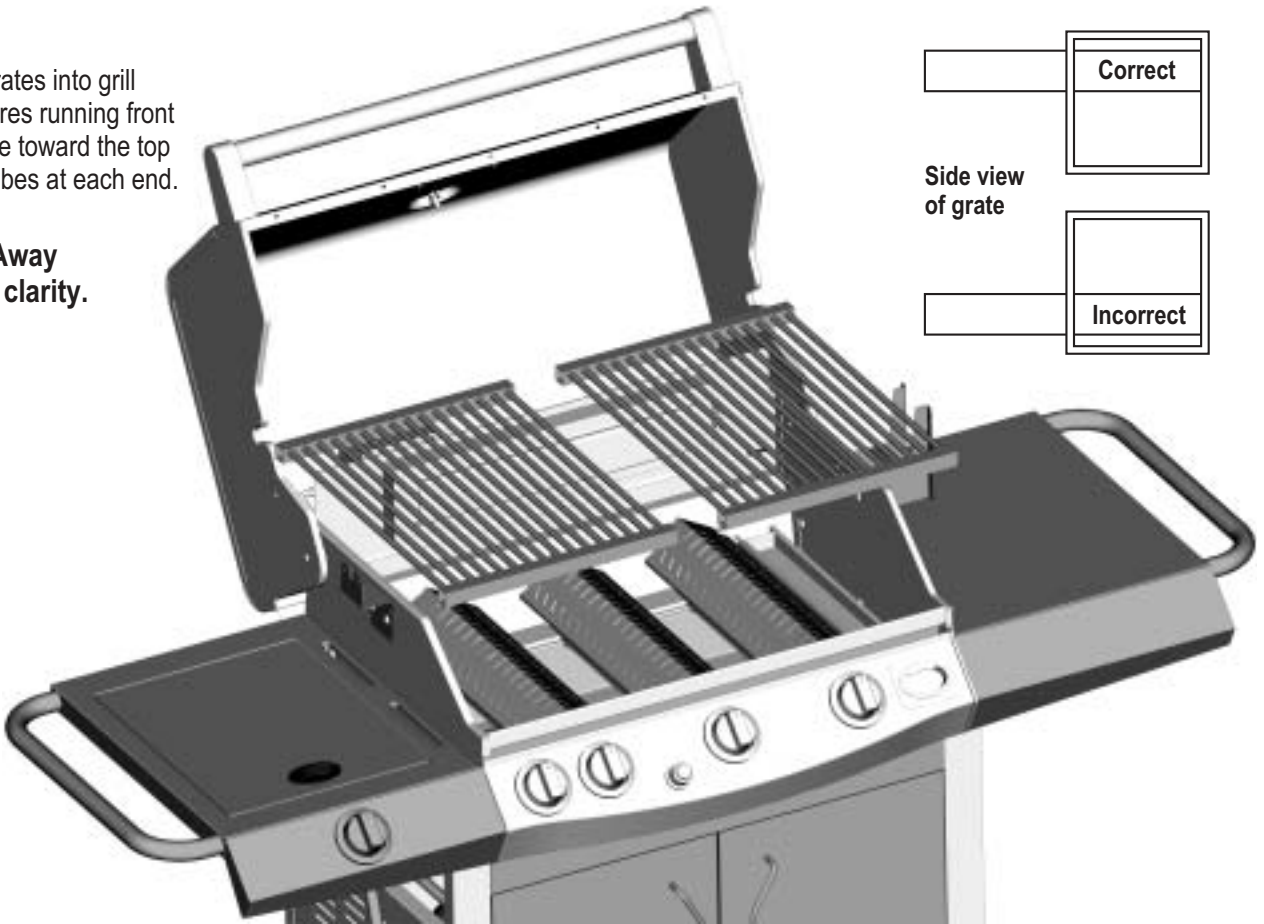

9

Open cart doors to attach condiment baskets. Large basket must attach to the right door, smaller basket to left door. Slide basket wires into brackets on doors.

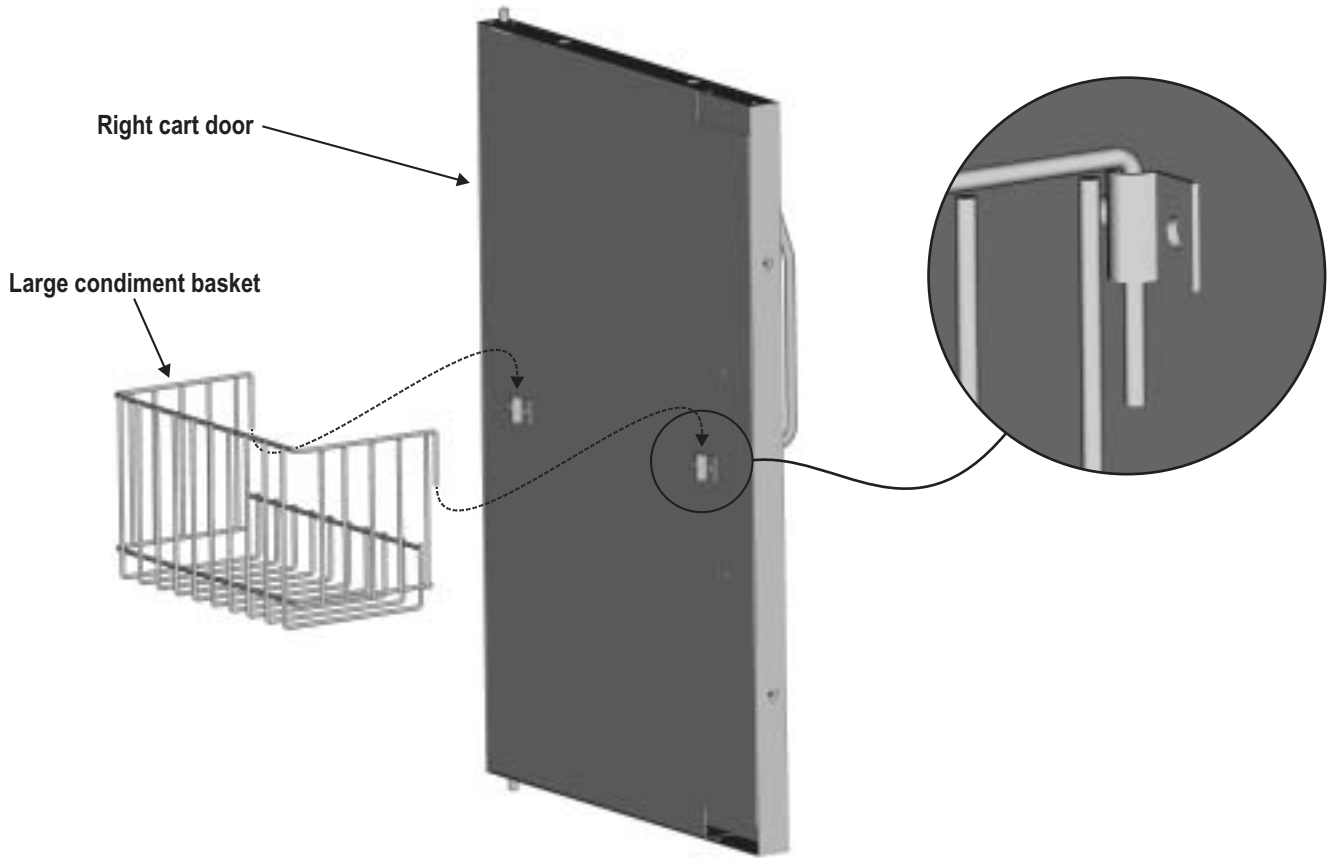

10

Hang the match-lighting stick and chain from the small hook on the right side panel.

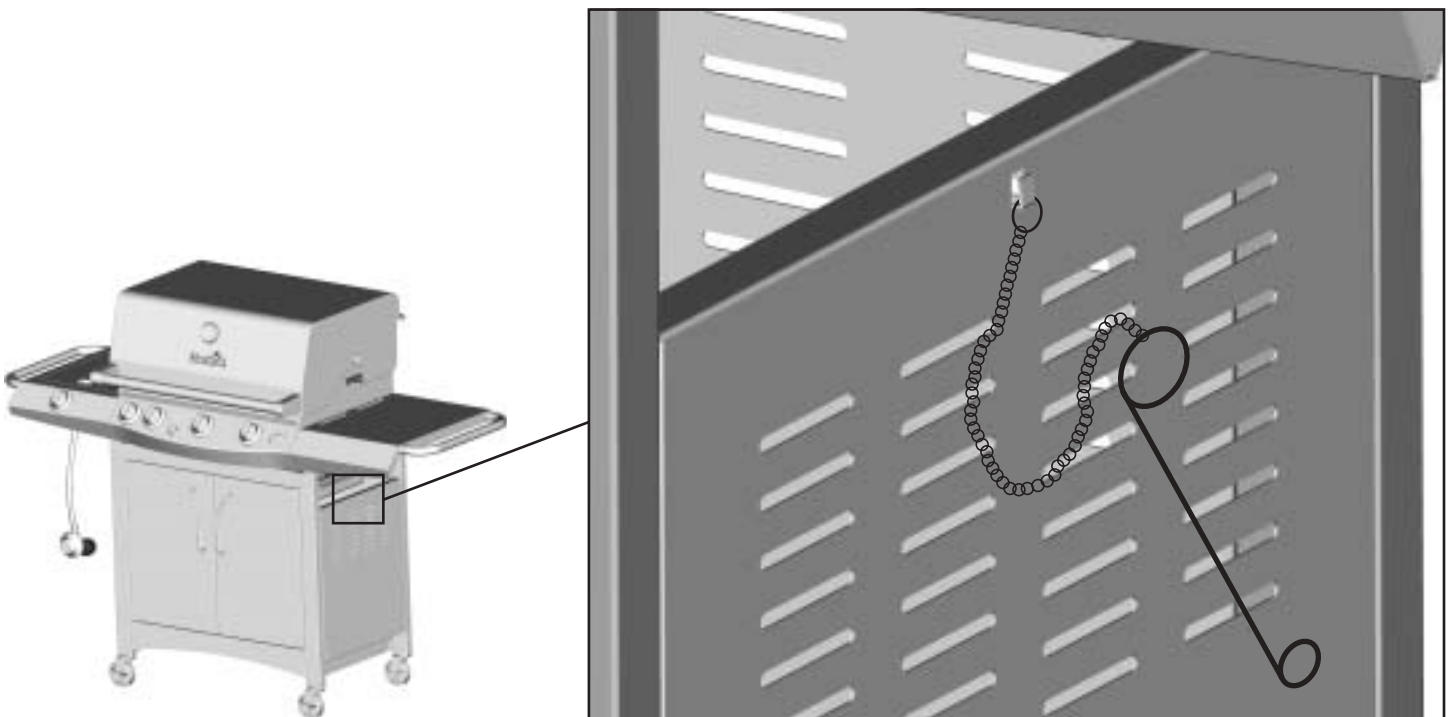

11

LP tank is sold separately. Fill and leak check the tank (see Use & Care section) before attaching to grill and regulator. Inside of cart, release the latch on the right side of the tank tray, slide tray out, and place LP tank into tank hole. Make sure tank valve is facing front of grill. Tighten the tank screw beneath the tray. Push the tray back into the cart and secure the latch. **See Use & Care manual to perform the “Burner Flame Check” and for important safety instructions before using.**



Tank tray latch.



Tank screw beneath grill.

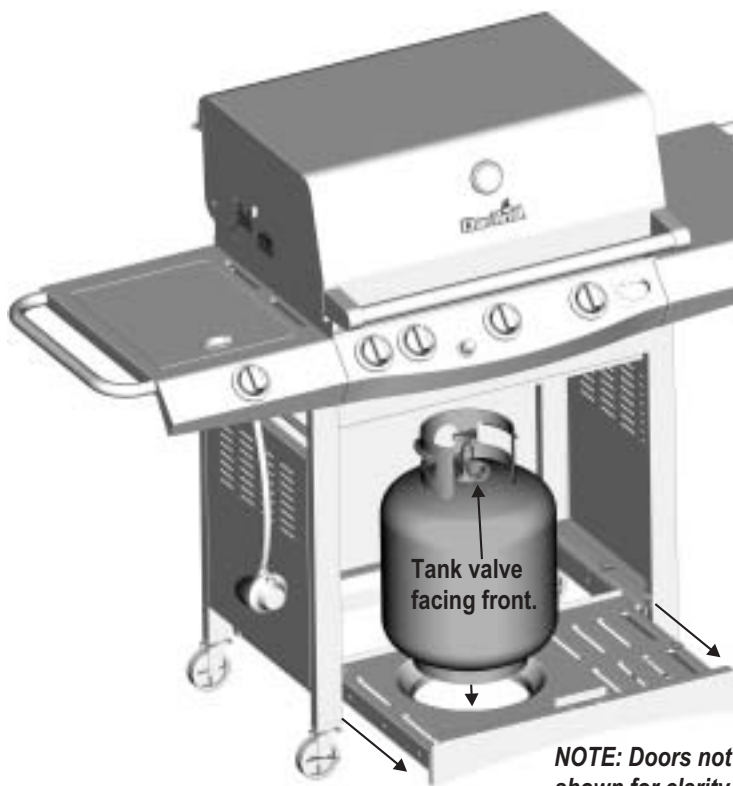

NOTE: Doors not shown for clarity.

	CAUTION	
<p>Tank valve must face to front of cart once tank is attached.</p>		
<p>Failure to install tank correctly may allow gas hose to be damaged in operation, resulting in the risk of fire.</p>		

12 VERY IMPORTANT!

Regulator and hose must pass **UNDER** hose bracket before connecting to LP tank. Read “Connecting Regulator to the LP Tank” in the Use and Care section of this manual.

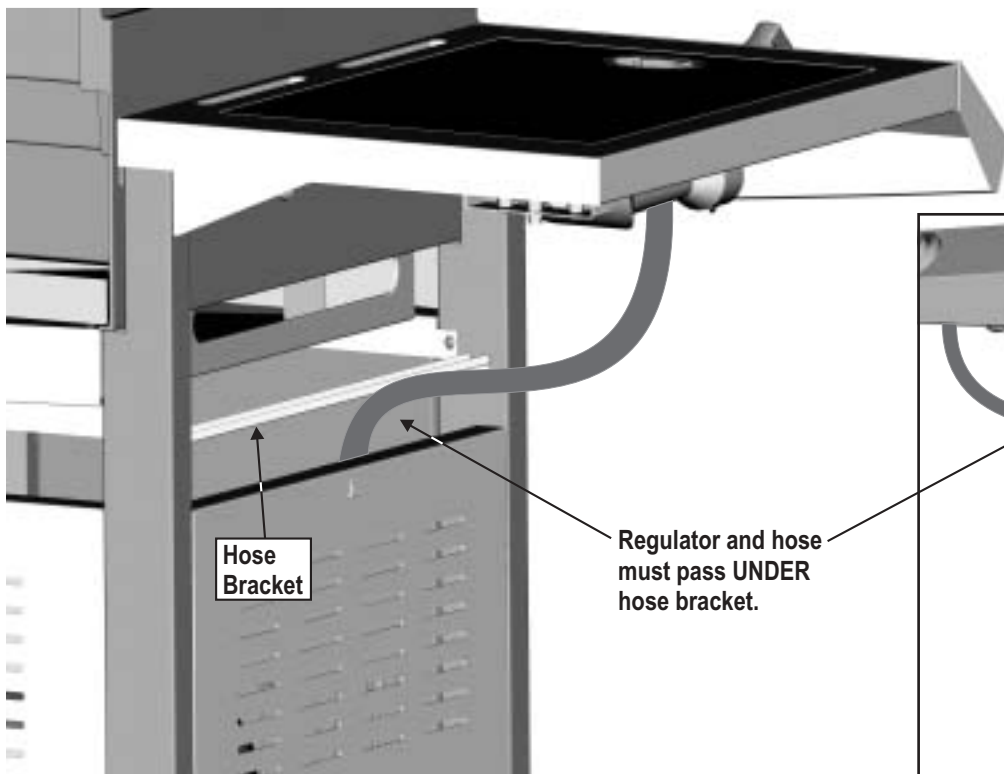

Hose Bracket

Regulator and hose must pass **UNDER** hose bracket.

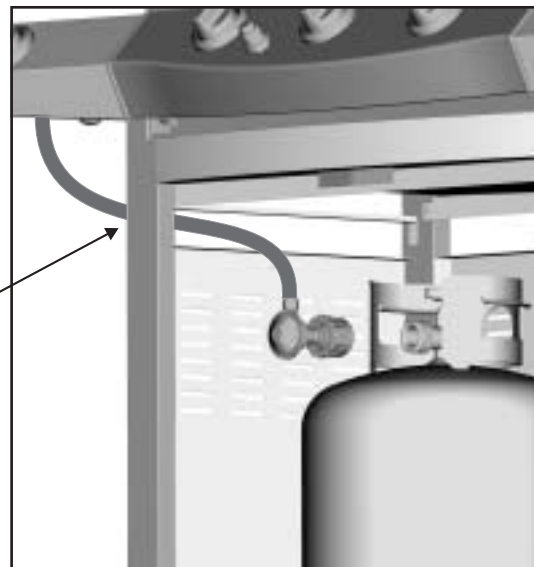

NOTE: Doors not shown for clarity.

13

Unscrew ignitor cap and place AA battery into ignitor slot with positive end (+) facing outward. Screw ignitor cap onto ignitor.

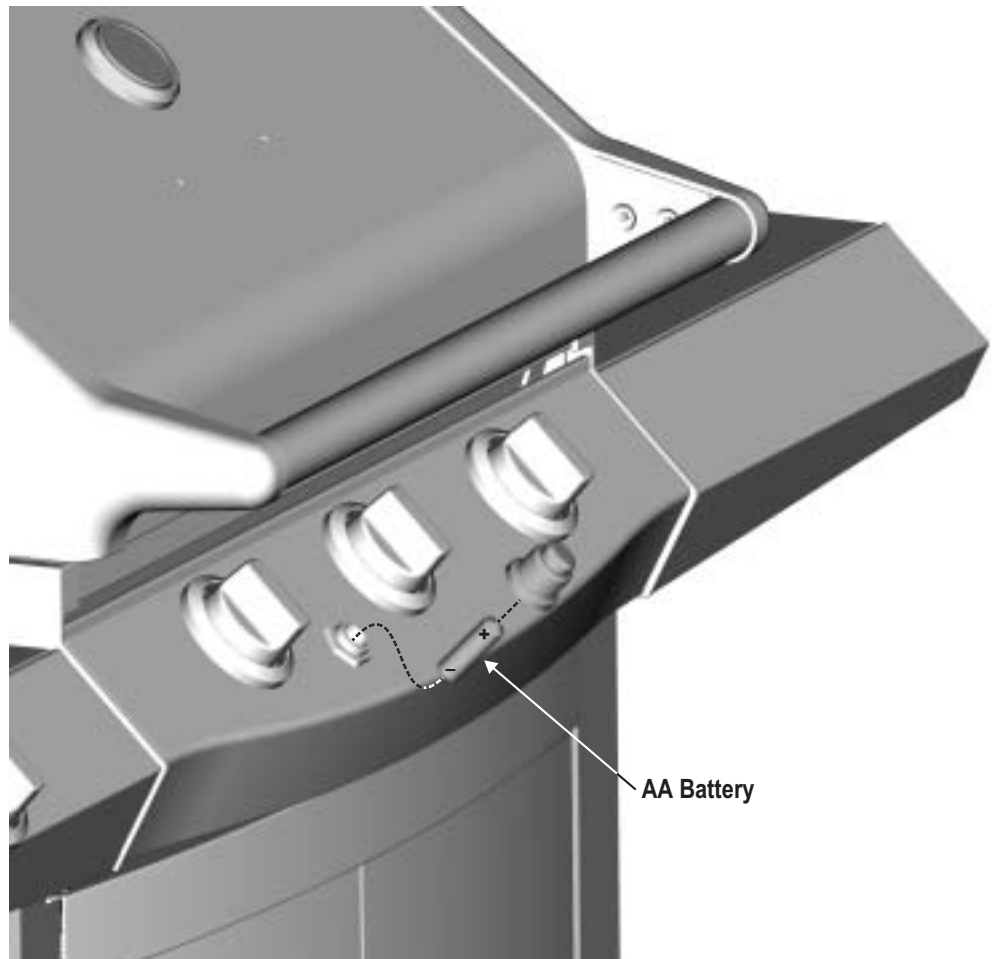

14

Twist the handle stopper fully onto threaded end of spit rod, then twist handle onto rod. Next, slide the collar onto the rod followed by the two forks (forks should be pointing toward each other). Insert thumbscrews into collar and forks.

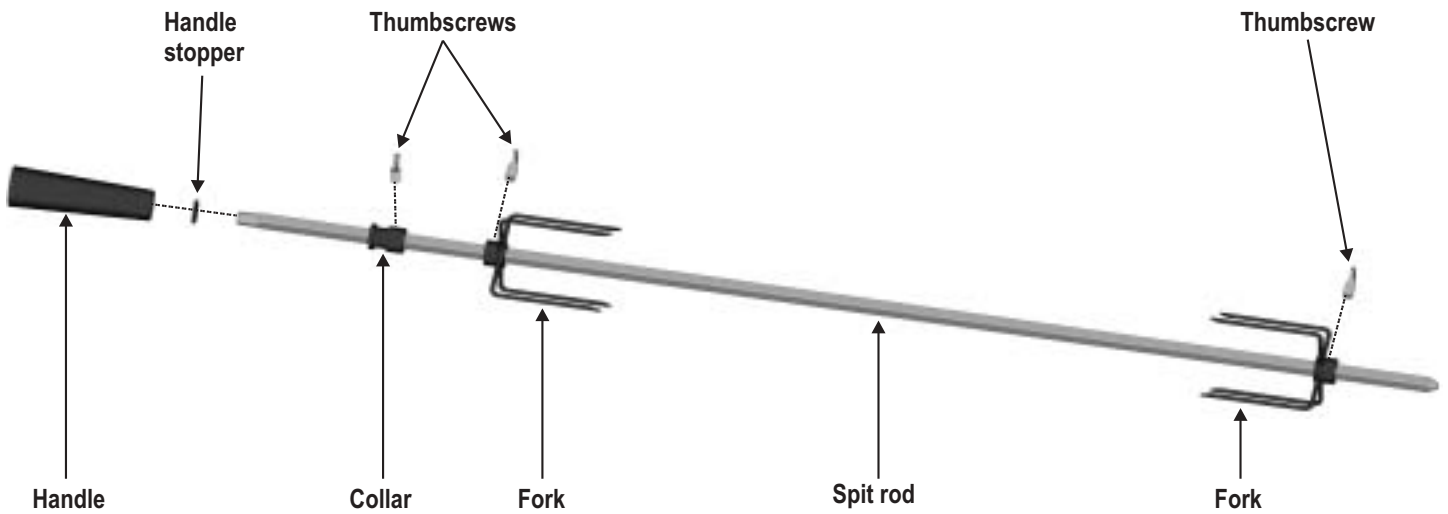

15

On right side of grill, slide rotisserie motor onto motor bracket. Switch should be oriented at top of motor. Insert spit rod fully into motor. On left side of grill, adjust position of collar to rest in bracket, then tighten collar thumbscrew.

NOTE: SwingAway must be removed when using rotisserie.

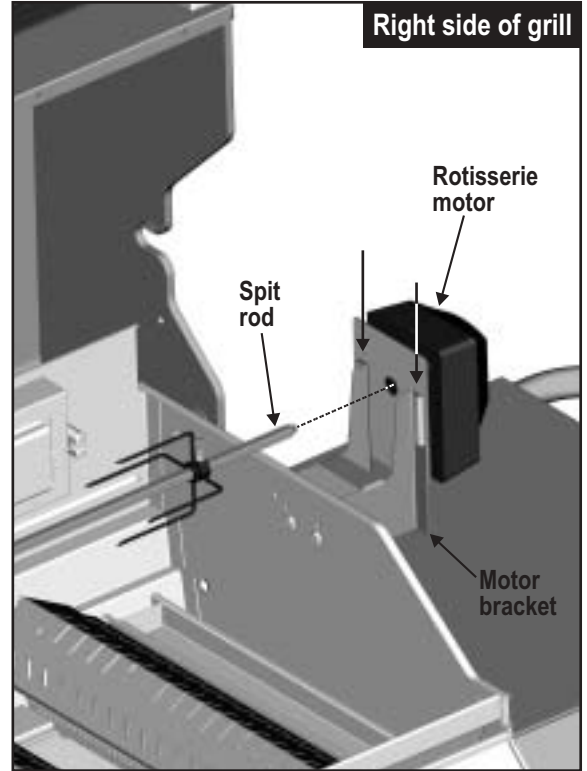
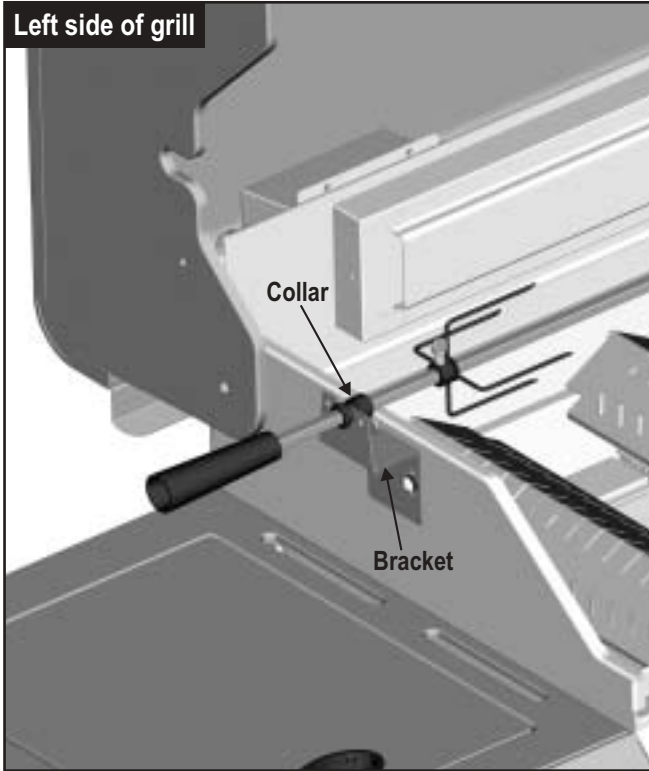

USE AND CARE



DANGER



- Never fill the cylinder beyond 80% full. An overfilled spare LP tank is hazardous due to possible gas released from the safety relief valve.
- The safety relief valve on the LP tank could activate, releasing gas, and cause an intense fire with risk of property damage, serious injury or death.
- NEVER store a spare LP tank under or near grill or in enclosed areas.
- If you see, smell or hear escaping gas, immediately get away from the LP tank/grill and call your fire department.
- All spare LP tanks must have safety caps installed on the LP tank outlet.

LP Tank Removal, Transport And Storage

- Turn OFF all control knobs and LP tank valve. Turn coupling nut counterclockwise by hand only - do not use tools to disconnect. Loosen tank screw beneath bottom shelf, then lift LP tank up and out of cart. Install safety cap onto LP tank valve. Always use cap and strap supplied with valve. **Failure to use safety cap as directed may result in serious personal injury and/or property damage.**

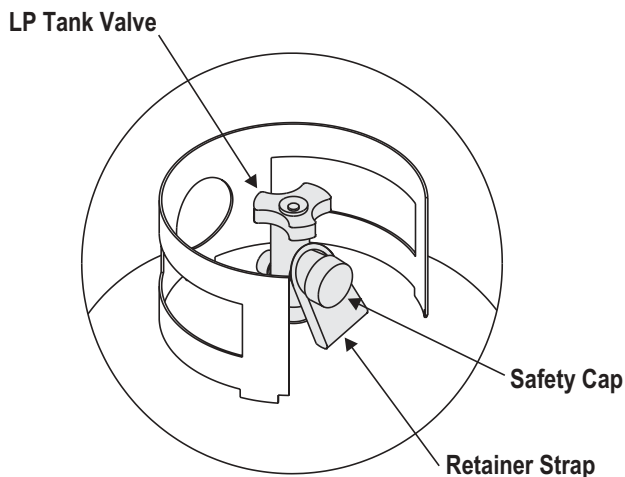

- A disconnected LP tank in storage or being transported must have a safety cap installed (as shown). Do not store an LP tank in enclosed spaces such as a carport, garage, porch, covered patio or other building. Never leave an LP tank inside a vehicle which may become overheated by the sun.
- Do not store an LP tank in an area where children play.

LP Tank

- The LP tank used with your grill must meet the following requirements:
- Use LP tanks only with these required measurements: 12" (30.5cm) (diameter) x 18" (45.7 cm) (tall) with 20 lb. (9 kg.) capacity maximum.
- LP tanks must be constructed and marked in accordance with specifications for LP tank of the U.S. Department of Transportation (DOT) or for Canada, CAN/CSA-B339, cylinders, spheres and tubes for transportation of dangerous goods, Transport Canada (TC). See LP tank collar for marking.
- LP tank valve must have:
 - Type 1 outlet compatible with regulator or grill.
 - Safety relief valve.
 - UL listed Overfill Protection Device (OPD). This OPD safety feature is identified by a unique triangular hand wheel. **Use only LP tanks equipped with this type of valve.**
- LP tank must be arranged for vapor withdrawal and include collar to protect LP tank valve.



OPD Hand Wheel

LP (Liquefied Petroleum Gas)

- LP gas is nontoxic, odorless and colorless when produced. **For Your Safety**, LP gas has been given an odor (similar to rotten cabbage) so that it can be smelled.
- LP gas is highly flammable and may ignite unexpectedly when mixed with air.

LP Tank Filling

- Use only licensed and experienced dealers.
- LP dealer **must purge new tank** before filling.
- Dealer should **NEVER** fill LP tank more than 80% of LP tank volume. Volume of propane in tank will vary by temperature.
- A frosty regulator indicates gas overfill. Immediately close LP tank valve and call local LP gas dealer for assistance.
- Do not release liquid propane (LP) gas into the atmosphere. This is a hazardous practice.
- To remove gas from LP tank, contact an LP dealer or call a local fire department for assistance. Check the telephone directory under "Gas Companies" for nearest certified LP dealers.

LP Tank Exchange

- Many retailers that sell grills offer you the option of replacing your empty LP tank through an exchange service. Use only those reputable exchange companies that inspect, precision fill, test and certify their cylinders. **Exchange your tank only for an OPD safety feature-equipped tank as described in the "LP Tank" section of this manual.**
- Always keep new and exchanged LP tanks in upright position during use, transit or storage.
- **Leak test new and exchanged LP tanks BEFORE connecting to grill.**

LP Tank Leak Test

For your safety

- Leak test must be repeated each time LP tank is exchanged or refilled.
 - Do not smoke during leak test.
 - Do not use an open flame to check for gas leaks.
 - Grill must be leak tested outdoors in a well-ventilated area, away from ignition sources such as gas fired or electrical appliances. During leak test, keep grill away from open flames or sparks.
 - Use a clean paintbrush and a 50/50 mild soap and water solution. Brush soapy solution onto areas indicated by arrows in figure below.
- ▲ **Do not use household cleaning agents.** Damage to gas train components can result.

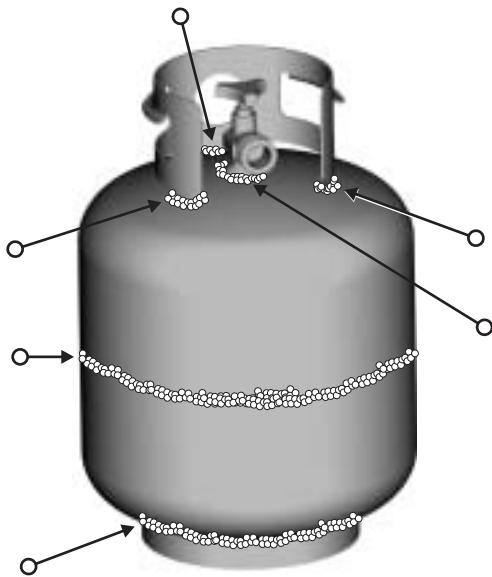

	WARNING	
If "growing" bubbles appear do not use or move the LP tank. Contact an LP gas supplier or your fire department!		

Connecting Regulator To The LP Tank

1. LP tank must be properly secured onto grill. (Refer to assembly section.)
2. Turn all control knobs, including sideburner, to the OFF position.
3. Turn LP tank OFF by turning hand-wheel clockwise to a **full stop**.
4. Remove the protective cap from LP tank valve. Always use cap and strap supplied with valve.

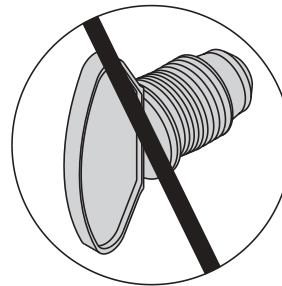
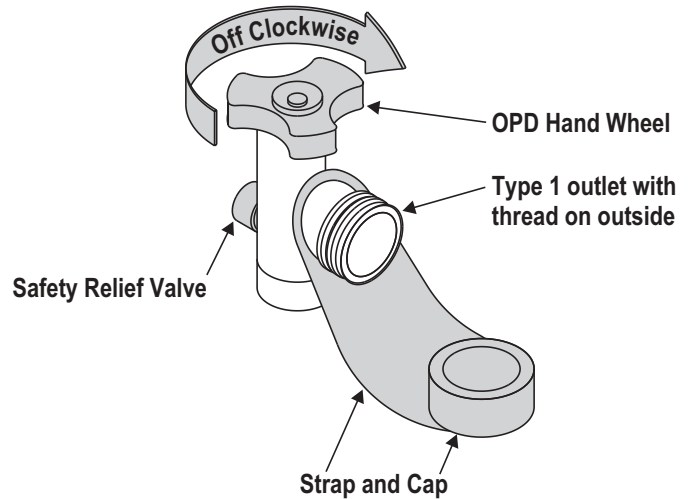

Do not use a POL transport plug (plastic part with external threads)! It will defeat the safety feature of the valve.

5. **Make sure hose and regulator pass UNDER hose bracket on cart (see assembly step 12).** Hold regulator and insert nipple into LP tank valve. Hand-tighten the coupling nut, holding regulator in a straight line with LP tank valve so as not to cross-thread the connection.

Nipple has to be centered into the LP tank valve.

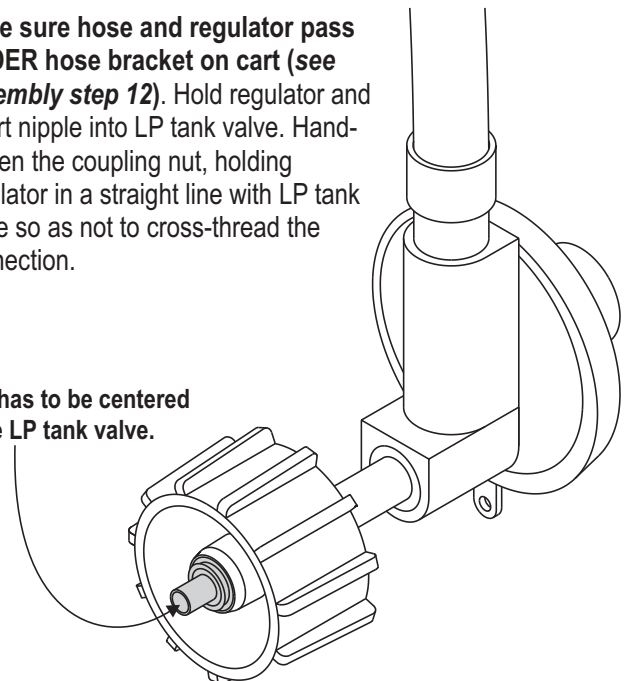

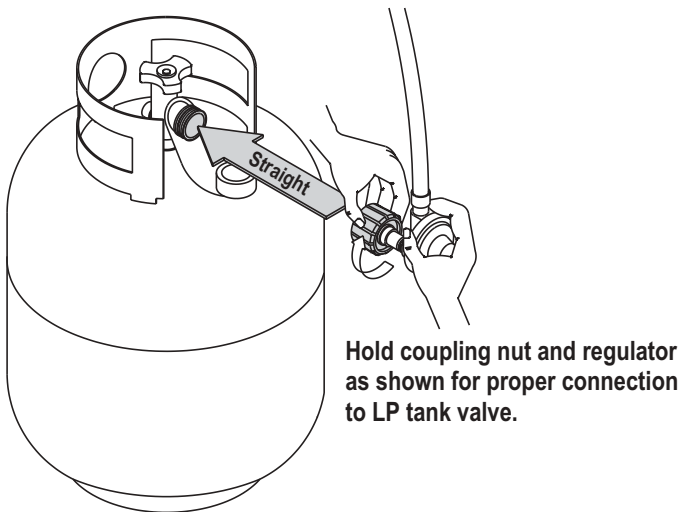

Hold coupling nut and regulator as shown for proper connection to LP tank valve.

6. Turn the coupling nut clockwise and tighten to a full stop. The regulator will seal on the back-check feature in the LP tank valve, resulting in some resistance. **An additional one-half to three-quarters turn is required to complete the connection. Tighten by hand only – do not use tools.**

NOTE:

If you cannot complete the connection, disconnect regulator and repeat steps 5 and 6. If you are still unable to complete the connection, **do not use this regulator!**

	WARNING	
<ul style="list-style-type: none"> • Do not insert any foreign objects into the valve outlet. You may damage the valve and cause a leak. Leaking propane may result in explosion, fire, severe personal injury, or death. • Never attempt to attach this grill to the self-contained LP gas system of a camper trailer or motor home. • Do not use grill until leak-tested. • If a leak is detected at any time, STOP and call the fire department. • If you cannot stop a gas leak, <i>immediately</i> close LP tank valve and call LP gas supplier or your fire department! 		

Leak Testing Valves, Hose and Regulator

1. Turn all grill control knobs to OFF.
2. Be sure regulator is tightly connected to LP tank.
3. Completely open LP tank valve by turning hand wheel counterclockwise. If you hear a *rushing sound*, turn gas off immediately. There is a major leak at the connection. **Correct before proceeding.**
4. Brush soapy solution onto areas circled below.

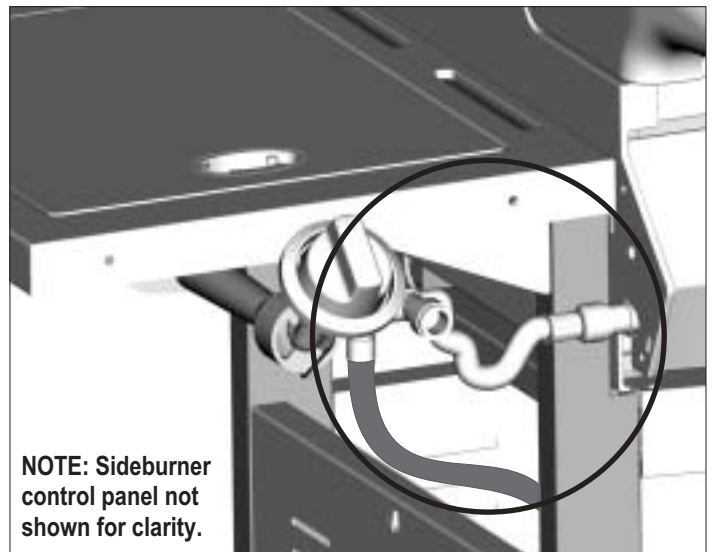
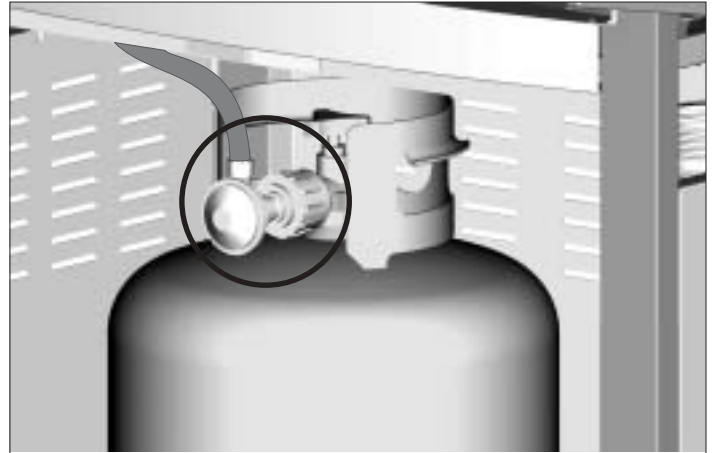

NOTE: Sideburner control panel not shown for clarity.

5. If “growing” bubbles appear, there is a leak. Close LP tank valve immediately and retighten connections. **If leaks cannot be stopped do not try to repair.** Call for replacement parts. Order new parts by giving the serial, model number and name of items needed to the Grill Service Center at 1-800-241-7548 (U.S.) or 1-800-387-6057 (CANADA).
6. Always close LP tank valve after performing leak test by turning hand wheel clockwise.



WARNING



For Safe Use Of Your Grill And To Avoid Serious Injury:

- Do not let children operate or play near grill.
- Keep grill area clear and free from materials that burn.
- Do not block holes in bottom or back of grill.
- Check burner flames regularly.
- Use grill only in well-ventilated space. NEVER use in enclosed space such as carport, garage, porch, covered patio, or under an overhead structure of any kind.
- Do not use charcoal or ceramic briquets in a gas grill. *(Unless briquets are supplied with your grill.)*
- **Use grill at least 3 ft. from any wall or surface.** Maintain 10 ft. clearance to objects that can catch fire or sources of ignition such as pilot lights on water heaters, live electrical appliances, etc..

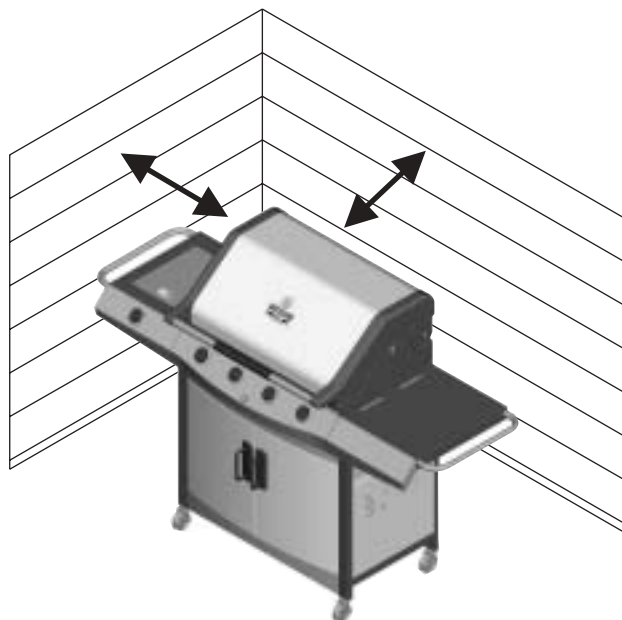

• Apartment Dwellers:

Check with management to learn the requirements and fire codes for using an LP gas grill in your apartment complex. If allowed, use outside on the ground floor with a three (3) foot clearance from walls or rails. Do not use on or under balconies.

- **NEVER attempt to light burner with lid closed. A buildup of non-ignited gas inside a closed grill is hazardous.**
- **Never operate grill with LP tank out of correct position specified in assembly instructions.**
- **Always close LP tank valve and remove coupling nut before moving LP tank from specified operation position.**

Safety Tips

- ▲ Before opening LP tank valve, check the coupling nut for tightness.
- ▲ When grill is not in use, turn off all control knobs and LP tank valve.
- ▲ Never move grill while in operation or still hot.
- ▲ Use long-handled barbecue utensils and oven mitts to avoid burns and splatters.
- ▲ Maximum load for sideburner and side shelf is 10 lbs.
- ▲ The grease receptacle **must** be attached to grease tray and emptied after each use. Do not remove grease receptacle until grill has completely cooled.
- ▲ If you notice grease or other hot material dripping from grill onto valve, hose or regulator, turn off gas supply at once. Determine the cause, correct it, then clean and inspect valve, hose and regulator before continuing. Perform a leak test.
- ▲ Keep ventilation openings in cylinder enclosure (grill cart) free and clear of debris.
- ▲ The regulator may make a humming or whistling noise during operation. This will not affect safety or use of grill.
- ▲ If you have a grill problem see the "Troubleshooting Section".



CAUTION



- **Putting out grease fires by closing the lid is not possible. Grills are well ventilated for safety reasons.**
- **Do not use water on a grease fire. Personal injury may result. If a grease fire develops, turn knobs and LP tank off.**
- **Do not leave grill unattended while preheating or burning off food residue on HI. If grill has not been regularly cleaned, a grease fire can occur that may damage the product.**

Ignitor Lighting

- ▲ **Do not lean over grill while lighting.**

1. **Open lid.** Turn on gas at LP tank.
2. To ignite, turn center burner knob to HI, push and hold ELECTRONIC IGNITOR button.
3. If ignition does NOT take place within 5 seconds, turn all burner valves to OFF, wait 5 minutes, then repeat lighting procedure.
4. To ignite left burner, turn left burner knob to HI.
5. To ignite right burner, turn right burner knob to HI.

Lighting instructions continued on next page.



CAUTION



If burner does not light, turn knobs to OFF, wait 5 minutes, and try again. If the burner does not ignite with the valve open, gas will continue to flow out of the burner and could accidentally ignite with risk of injury.

Match-Lighting

▲ Do not lean over grill while lighting.

1. **Open lid.** Turn on gas at LP tank.
2. Place lit match into match lighting stick, then into lighting hole on right side of grill.
3. Push in and turn far right burner knob to HI. Be sure burner lights and stays lit.
4. Light adjacent burners in sequence by pushing knobs in and turning to HI.

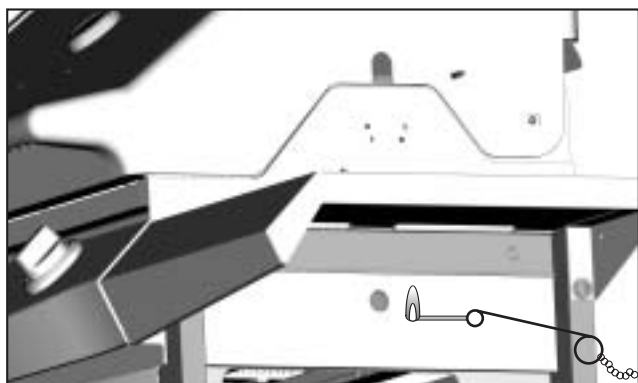

Ignitor Lighting The Sideburner

▲ Do not lean over grill while lighting.

1. To ignite sideburner, open sideburner cover.
2. Turn sideburner knob to HI, push and hold ELECTRONIC IGNITOR button.
3. If sideburner does NOT light, turn knob to OFF, wait 5 minutes, then repeat lighting procedure or use match.

Match Lighting

1. To match light sideburner, open sideburner cover.
2. Place lit match near burner.
3. Push in and turn sideburner knob counterclockwise. Be sure burner lights and stays lit.

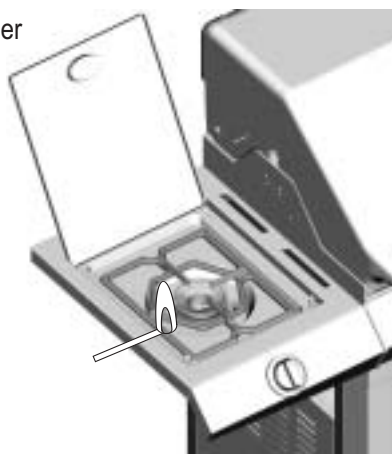

Ignitor Lighting The Rotisserie Burner

▲ Do not lean over grill while lighting.

1. Open lid during lighting.
2. To ignite rotisserie burner, turn rotisserie burner knob to ON, push and hold ELECTRONIC IGNITOR button for 5 seconds.
3. If rotisserie burner does NOT light, turn knob to OFF, wait 5 minutes, then repeat lighting procedure or use match.

Match Lighting

1. Open lid during lighting.
2. Place lit match near rotisserie spark electrode wire.
3. Push in and turn rotisserie burner knob to ON. Be sure burner lights and stays lit.

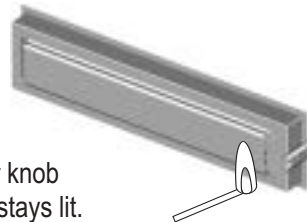

NOTE: Do not operate the rotisserie burner and the main burners at the same time.

Burner Flame Check

- Remove grates and flamelamers. Light burner, rotate knobs from HI to LOW. You should see a smaller flame in LO position than seen on HI. Always check flame prior to each use. Perform flame check on sideburner. If only low flame is seen refer to "Sudden drop or low flame" in the *Troubleshooting Section*.

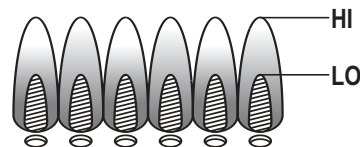

Turning Grill Off

- Turn all knobs to **OFF** position. Turn LP tank off by turning hand-wheel clockwise to a full stop.

Ignitor Check

- **Turn gas off at LP tank.** Press and hold electronic ignitor button. "Click" should be heard and spark seen each time between collector box or burner and electrodes. See "*Troubleshooting*" if no click or spark.

Valve Check

- **Important: Make sure gas is off at LP tank before checking valves.** Knobs lock in **OFF** position. To check valves, first push in knobs and release, knobs should spring back. If knobs do not spring back, replace valve assembly before using grill. Turn knobs to **LO** position then turn back to **OFF** position. Valves should turn smoothly.

Hose Check

- Before each use, check to see if hoses are cut or worn. Replace damaged hoses before using grill. Use only valve/hose/regulator specified by manufacturer.

General Grill Cleaning

- Do not mistake brown or black accumulation of grease and smoke for paint. Interiors of gas grills are not painted at the factory (**and should never be painted**). Apply a strong solution of detergent and water or use a grill cleaner with scrub brush on insides of grill lid and bottom. Rinse and allow to completely air dry. **Do not apply a caustic grill/oven cleaner to painted surfaces.**
- **Plastic parts:** Wash with warm soapy water and wipe dry.
 - ▲ Do not use citrisol, abrasive cleaners, degreasers or a concentrated grill cleaner on plastic parts. Damage to and failure of parts can result.
- **Porcelain surfaces:** Because of glass-like composition, most residue can be wiped away with baking soda/water solution or specially formulated cleaner. Use nonabrasive scouring powder for stubborn stains.
- **Painted surfaces:** Wash with mild detergent or nonabrasive cleaner and warm soapy water. Wipe dry with a soft nonabrasive cloth.
- **Stainless steel surfaces:** To maintain your grill's high quality appearance, wash with mild detergent and warm soapy water and wipe dry with a soft cloth after each use. Baked-on grease deposits may require the use of an abrasive plastic cleaning pad.

Storing Your Grill

- Clean cooking grates.
- Store in dry location.
- When LP tank is connected to grill, store outdoors in a well-ventilated space and out of reach of children.
- Cover grill if stored outdoors. Choose from a variety of grill covers offered by manufacturer.
- Store grill indoors **ONLY** if LP tank is turned off and disconnected, removed from grill and stored outdoors.
- When removing grill from storage, follow "*Cleaning the Burner Assembly*" instructions before starting grill.

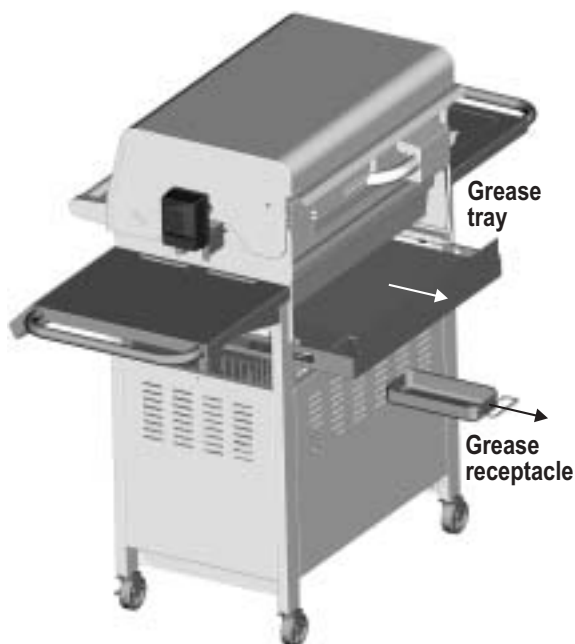

Grease Tray and Receptacle

MAKE SURE GRILL IS COOL. To empty the grease receptacle, grasp the handle and slide it out of grease tray. To remove grease tray for cleaning, lift it from the back and slide entire tray out of cart.

	CAUTION	
NATURAL HAZARD • SPIDERS		
FACT: Sometimes spiders and other small insects climb into the burner tubes attached to the burners. The spiders spin webs, build nests and lay eggs. The webs or nests can be very small, but they are very strong and can block the flow of gas. Clean burners prior to use after storing, at the beginning of grilling season or after a period of one month not being used.		
Spider guards are on the air intakes in an effort to reduce this problem, but it will not eliminate it! An obstruction can result in a "flashback" (a fire in the burner tubes). The grill may still light, but the obstruction does not allow full gas flow to the burners.		
IF YOU EXPERIENCE THE FOLLOWING:		
<ol style="list-style-type: none">1. Smell gas.2. Burner(s) will not light.3. A small yellow flame from burner (should be blue).4. Fire coming from around or behind control knob.		
STOP!		
Immediately turn off gas at LP tank!		
SOLUTION:		
Wait for grill to cool.		
Follow the " <i>Cleaning The Burner Assembly</i> " instructions. Clean burners often. Use a 12" pipe cleaner to clean out the burner tubes. You may also force a stream of water from a hose nozzle through burner tubes to clean them.		

	CAUTION	
• Failure to install receptacle on tray will cause hot grease to drip from bottom of grill with risk of fire or property damage.		

Cleaning The Burner Assembly

Follow these instructions to clean and/or replace parts of burner assembly or if you have trouble igniting grill.

1. **Turn gas off at control knobs and LP tank.**
2. Remove cooking grates, flametamers, grease tray and grease receptacle.
3. Remove cotter pins from beneath each burner "foot" using a screwdriver or needle nose pliers.
4. Carefully lift each burner up and away from valve openings.

We suggest three ways to clean the burner tubes. Use the one easiest for you.

- (A) Bend a stiff wire (a light weight coat hanger works well) into a small hook. Run the hook through each burner tube and burner several times.

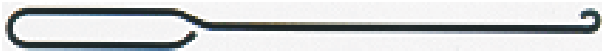

- (B) Use a narrow bottle brush with a flexible handle (do not use a brass wire brush), run the brush through each burner tube and burner several times.

- (C) **Wear eye protection:** Use an air hose to force air into the burner tube and out the burner ports. Check each port to make sure air comes out each hole.

5. Wire brush entire outer surface of burner to remove food residue and dirt.
6. Clean any blocked ports with a stiff wire such as an open paper clip.
7. Check burner for damage, due to normal wear and corrosion some holes may become enlarged. If any large cracks or holes are found replace burner.

VERY IMPORTANT: Burner tubes must reengage valve openings. See illustrations below.

8. Carefully replace burners.
9. Replace cotter pin beneath each burner.
10. Replace grease tray, grease receptacle, flametamers and cooking grates.

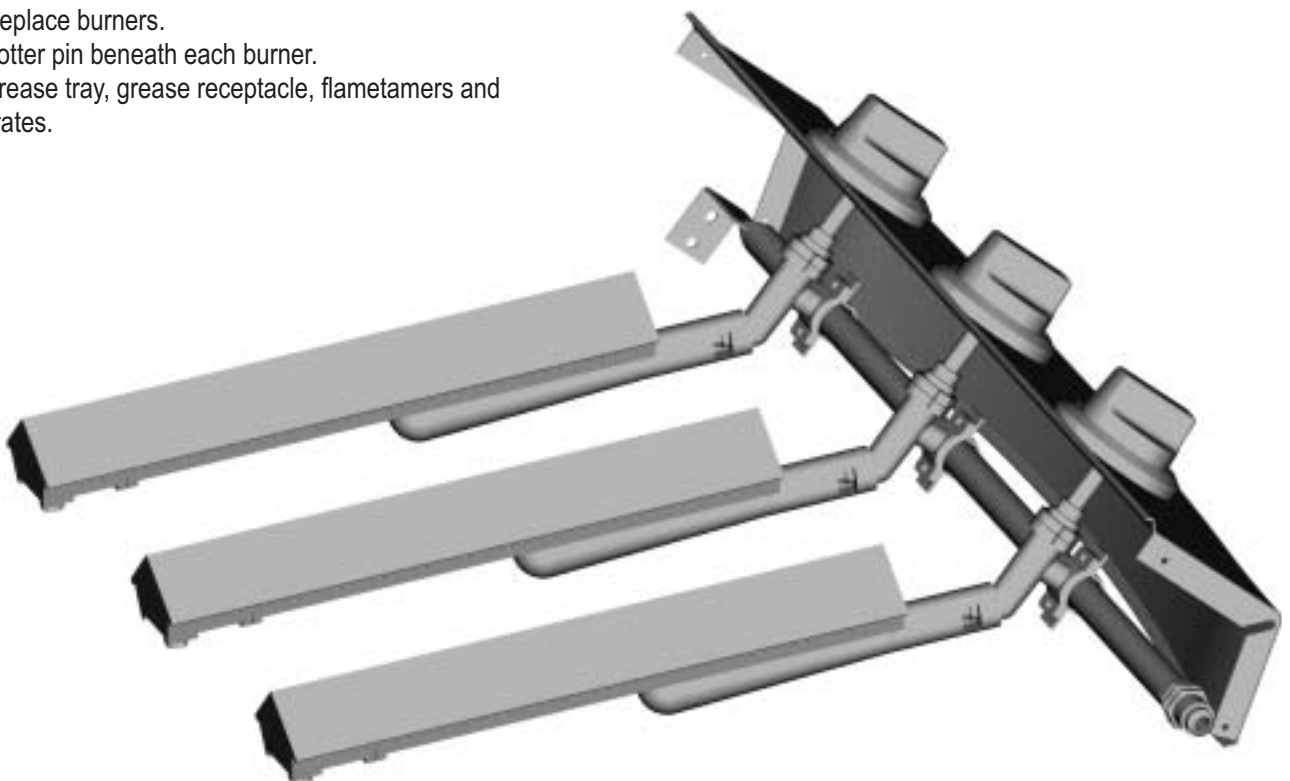
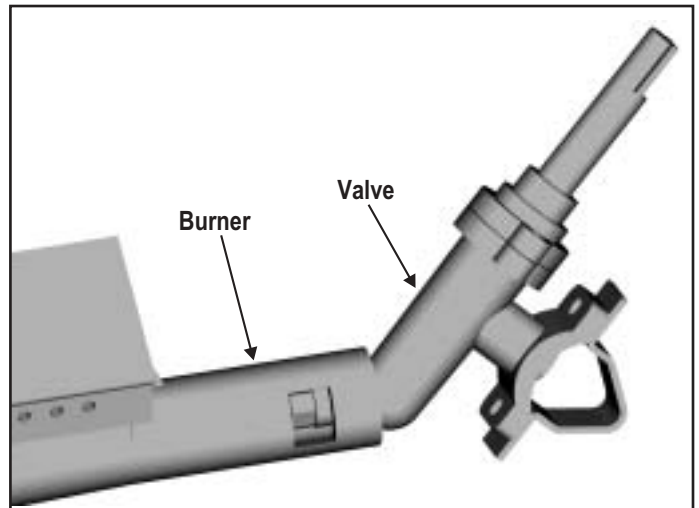

Indirect Cooking

Poultry and large cuts of meat cook slowly to perfection on the grill by indirect heat. The heat from selected burners circulates gently throughout the grill, cooking meat or poultry without the touch of a direct flame. This method greatly reduces flare-ups when cooking extra fatty cuts because there is no direct flame to ignite the fats and juices that drip during cooking.

Indirect Cooking Instructions

- Always cook with the lid closed.
- Due to weather conditions, cooking times may vary. During cold and windy conditions the temperature setting may need to be increased to insure sufficient cooking temperatures.



1 Burner Cooking

Cook with direct or indirect heat.
Best for smaller meals or foods.
Consumes less fuel.

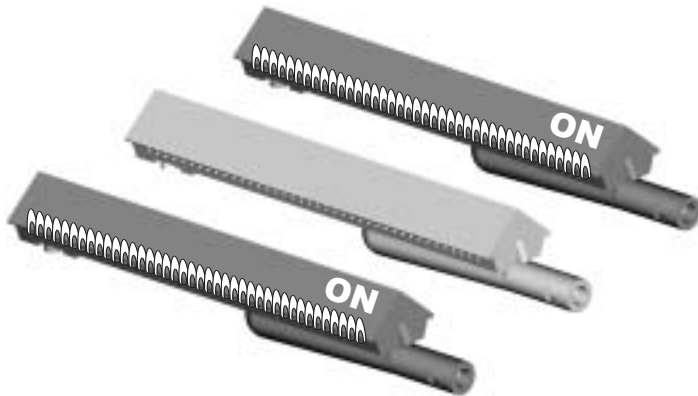

2 Burner Cooking

Great indirect cooking on low.
Produces slow, even heating.
Ideal for slow roasting and baking.

Using the Smoker Tray

1. **While the grill is cool**, remove the right cooking grate.
2. Add enough wood chips to completely fill the smoker tray.
3. Light the center main burner first, then the right burner, then turn the center burner off.
4. Place food on the left cooking grate. Wood chips should begin smoking within 15 minutes.

Make sure grill has completely cooled before emptying smoker tray. To empty the smoker tray, pull the tray completely out of the grill bottom through the control panel.

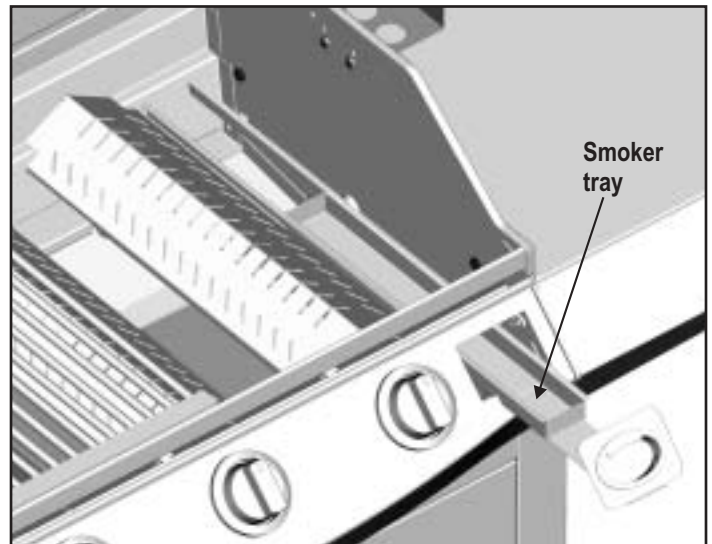

How To Tell If Meat Is Grilled Thoroughly

- Meat and poultry cooked on a grill often browns very fast on the outside. Use a meat thermometer to be sure food has reached a safe internal temperature, and cut into food to check for visual signs of doneness.
- Whole poultry should reach 180° F; breasts, 170° F. Juices should run clear and flesh should not be pink.
- Hamburgers made of any ground meat or poultry should reach 160° F, and be brown in the middle with no pink juices. Beef, veal and lamb steaks, roasts and chops can be cooked to 145° F. All cuts of pork should reach 160° F.
- NEVER partially grill meat or poultry and finish cooking later. Cook food completely to destroy harmful bacteria.
- When reheating takeout foods or fully cooked meats like hot dogs, grill to 165° F, or until steaming hot.

Troubleshooting

Problem	Possible Cause	Prevention/Solution
Burner(s) will not light using ignitor.	<ul style="list-style-type: none"> Wire and/or electrode covered with cooking residue. Electrode cracked or broken "sparks at crack". Electrode tip not in proper position. Wires are loose or disconnected. Wires are shorting (sparking) between ignitor and electrode. Dead battery. 	<ul style="list-style-type: none"> Clean wire and/or electrode with rubbing alcohol and clean swab. Replace electrode(s). Main Burners: Tip of electrode should be pointing toward tip of collector box. The distance should be 1/8" to 1/4", adjust if necessary. Sideburner: Tip of electrode should be pointing toward gas port opening on burner. The distance should be 1/8" to 3/16", adjust if necessary. Reconnect wires or replace electrode/wire assembly. Replace ignitor wire/electrode assembly. Replace with a new AA battery.
Burner(s) will not match light.	<ul style="list-style-type: none"> No gas flow. Coupling nut and regulator not fully connected. Obstruction of gas flow. Disengagement of burner to valve. Is grill assembled correctly? 	<ul style="list-style-type: none"> Check to see if LP tank is empty. If LP tank is not empty, refer to "Sudden drop in gas flow". Turn the coupling nut about one-half to three quarters additional turn until solid stop. Tighten by hand only-do not use tools. Clear burner tube(s). Reengage burner and valve. Check steps in assembly instructions.
Sudden drop in gas flow or low flame.	<ul style="list-style-type: none"> Out of gas. Excess flow valve tripped. 	<ul style="list-style-type: none"> Check for gas in LP tank. Turn off knobs, wait 30 seconds and light grill. If flames are still low, turn off knobs and LP tank valve. Disconnect regulator. Reconnect regulator and leak test. Turn on LP tank valve, wait 30 seconds and then light grill.
Flames blow out.	<ul style="list-style-type: none"> High or gusting winds. Low on LP gas. Excess flow valve tripped. 	<ul style="list-style-type: none"> Turn front of grill to face wind or increase flame height. Refill LP tank. Refer to "Sudden drop in gas flow" above.
Flare-up.	<ul style="list-style-type: none"> Grease buildup. Excessive fat in meat. Excessive cooking temperature. 	<ul style="list-style-type: none"> Clean grill. Trim fat from meat before grilling. Adjust (lower) temperature accordingly.
Persistent grease fire.	<ul style="list-style-type: none"> Grease trapped by food buildup around burner system. 	<ul style="list-style-type: none"> Turn knobs to OFF. Turn gas off at LP tank. Leave lid in position and let fire burn out. <i>After grill cools, remove and clean all parts.</i>
Flashback... (fire in burner tube(s)).	<ul style="list-style-type: none"> Burner and/or burner tubes are blocked. 	<ul style="list-style-type: none"> Turn knobs to OFF. Clean burner and/or burner tubes.
Unable to fill LP tank.	<ul style="list-style-type: none"> Some dealers have older fill nozzles with worn threads. 	<ul style="list-style-type: none"> The worn nozzles don't have enough "bite" to engage the valve. Try a second LP dealer.

Certified Grill Parts And Accessories®, Char-Broil and Design®, Char-Broil (Gas Grill Briquettes)®, Char-Diamonds®, Cooking Zone and Design®, Diamond Flame®, Executive Chef®, Faststart®, Flare Fighter®, FlavorMaster®, Gas Grill Silhouette and Design®, H2O Smoker®, Lava Flame®, MasterFlame®, MasterFlame Precision Cooking System®, PowerSpark®, Quantum®, VIP®, PrecisionFlame and Design®, Sierra®, and TruFlame® are registered Trademarks of the W.C. Bradley Company. Thermos® is a registered trademark of the Thermos Company and its affiliates.

Artisan Collection by Char-Broil™, C3 and Design™, Char-Broil and Design™, Flame Design™, FlavorTents™, Grill 2 Go™, Grillin' Stick™, Keeper of the Flame™, Keepers of the Flame™, Natural Grip™, Outdoor Cooking Collection and Design™, Patio Bistro™, PrecisionFlame™, Pro-Check™, QuickSet Grills and Design™, SmokerTents™, The Big Easy™, The Minute Grill™, The Edge™, The Tuscan Collection™, and The Urban Grill™ are Trademarks of the W.C. Bradley Company. Universal Grill Parts and Design™ is a trademark of the Thermos Company and its affiliates.

Protected under one or more of the following U.S. Patents: 4,598,692; 4,624,240; 4,747,391; 4,747,391; 4,817,583; 4,924,846; 4,989,579; 5,003,960; 5,076,256; 5,076,257; 5,090,398; 5,109,834; 5,224,676; 5,277,106; 5,421,319; 5,441,226; 5,452,707; 5,458,309; 5,566,606; 5,566,606; 5,579,755; 5,582,094; 5,613,486; 5,649,475; 5,706,797; 5,711,663; 5,765,543; 5,931,149; 5,996,573; 6,095,132; 6,135,104; 6,173,644B1; 6,279,566; 6,397,731; 6,418,923; 6,439,222; 6,523,461; D282,619; D339,714; D341,292; D343,337; D358,059; D361,466; D364,535; D372,637; D373,701; D377,735; D383,035; D397,910; D405,643; D405,643; D406,005; D406,009; D413,043; D413,229; D413,229; D414,982; D415,388; D416,164; D416,441; D416,441; D417,587; D422,516; D423,274; D423,876; D428,303; D435,396; D436,004; D438,059; D438,060; D438,427; D439,110; D442,505; D443,179; D443,354; D447,384; D447,385; D447,909; D448,610; D448,614; D448,615; D448,616; D448,975; D449,492; D451,759; D456,202S; D460,313 and D461,359. Canada: 87743; 87744; 92607; 92608 and 1,316,424. Other Patents Pending.

Troubleshooting - Electronic Ignition

Problem	Possible Cause	Check Procedure	Prevention/Solution
No sparks appear at any electrodes when ignition button is pushed; no noise can be heard from spark module.	<ul style="list-style-type: none"> Battery not installed properly. Dead battery. Button assembly not installed properly. Faulty spark module. 	<ul style="list-style-type: none"> Check battery orientation. Has battery been used previously? Check to insure threads are properly engaged. Button should travel up and down without binding. If no sparks are generated with new battery and good wire connections, module is faulty. 	<ul style="list-style-type: none"> Install battery (make sure that “+” and “-” connectors are oriented correctly, with “+” end up and “-” end down.) Replace battery with new AA-size alkaline battery. Unscrew button cap assembly and reinstall, making sure threads are aligned and engaged fully. Replace spark module assembly.
No sparks appear at any electrodes when ignition switch is pushed; noise can be heard from spark module.	<ul style="list-style-type: none"> Output lead connections not complete. 	<ul style="list-style-type: none"> Are output connections on and tight? 	<ul style="list-style-type: none"> Remove and reconnect all output connections at module and electrodes.
Sparks are present but not at all electrodes and/or not at full strength	<ul style="list-style-type: none"> Output lead connections not complete. Arcing to grill away from burner(s). Weak battery. Electrodes are wet. Electrodes cracked or broken “sparks at crack”. 	<ul style="list-style-type: none"> Are output connections on and tight? If possible, observe grill in dark location. Operate ignition system and look for arcing between output wires and grill frame. All sparks present but weak or at slow rate. Has moisture accumulated on electrode and/or in burner ports? Inspect electrodes for cracks. 	<ul style="list-style-type: none"> Remove and reconnect all output connections at module and electrodes. If sparks are observed other than from burner(s), wire insulation may be damaged. Replace wires. Replace battery with a new AA-size alkaline battery. Use paper towel to remove moisture. Replace cracked or broken electrodes.

Food Safety

Food safety is a very important part of enjoying the outdoor cooking experience. To keep food safe from harmful bacteria, follow these four basic steps:

Clean: Wash hands, utensils, and surfaces with hot soapy water before and after handling raw meat and poultry.

Separate: Separate raw meats and poultry from ready-to-eat foods to avoid cross contamination. Use a clean platter and utensils when removing cooked foods.

Cook: Cook meat and poultry thoroughly to kill bacteria. Use a thermometer to ensure proper internal food temperatures.

Chill: Refrigerate prepared foods and leftovers promptly.

For more information call: USDA Meat and Poultry Hotline at 1-800-535-4555 In Washington, DC (202) 720-3333, 10:00 am-4:00 pm EST.



A Division of W.C. Bradley Co. • Columbus, GA 31902