

This Owner's Manual is provided and hosted by [Appliance Factory Parts](#).



# FISHER PRICE B1476-MADE-BEFORE-3-24-03 Owner's Manual

[Shop genuine replacement parts for FISHER PRICE  
B1476-MADE-BEFORE-3-24-03](#)



[Find Your FISHER PRICE Ride On Parts - Select From 999 Models](#)

----- Manual continues below -----

# CHEVROLET<sup>®</sup> **SILVERADO<sup>™</sup>**



Product features may vary from the picture above.

Please read this manual and save it with your original sales receipt.  
Tools needed for assembly: Phillips Screwdriver and Hammer (tools not included).  
Use only with a Power Wheels<sup>®</sup> 12 Volt Lead-Acid Rechargeable Battery and  
a Power Wheels<sup>®</sup> 12 Volt Charger with Type "12V" Connector (both included).



Chevrolet, Chevy, The Bow Tie, Silverado emblems and vehicle body designs are General Motors trademarks used under license to Fisher-Price, Inc. Goodyear (and winged foot design) and Wrangler (for tires) are trademarks of The Goodyear Tire & Rubber Company, used with permission.

Fisher-Price, Power Wheels, Power Wheels by Fisher-Price, Power Lock and Power Stick are U.S. trademarks of Mattel, Inc.

[www.powerwheels.com](http://www.powerwheels.com)



## Owner's Manual with Assembly Instructions

For Model B1476

# Table of Contents

A	Important Information	.2
B	Warnings and Cautions	.3
C	Parts	.4
D	Parts Diagram	.6
E	Battery Charging	.7
F	Assembly	.9
G	Label Decoration	.16
H	Battery Installation	.18
I	Battery Care and Disposal	.19
J	Rules for Safe Driving	.20
K	How to Operate Your Vehicle	.21
L	Caring for Your Vehicle	.22
M	Problems and Solutions Guide	.23
N	Limited Warranty	.27

## A

## Important Information

- Your new vehicle requires adult assembly. Please set aside at least 45 minutes for assembly.
- You must charge your battery for 18 - 30 hours **before you use your vehicle for the first time**. We recommend that you start charging your battery before beginning assembly. Please see Battery Charging beginning on page 7 for detailed instructions.
- Read this manual carefully for important safety information and operating instructions before using your vehicle. Keep these instructions for future reference as they contain important information.
- Use this vehicle **ONLY** outdoors. Most interior flooring can be damaged by riding this vehicle indoors. Fisher-Price® will not be responsible for damage to floors if the vehicle is used indoors.
- This vehicle is designed for use on grass, asphalt or other hard surfaces; on generally level terrain; by children 3 years of age and older.
- Make sure children know and follow these rules for safe driving and riding:
  - always sit in the seat.
  - always wear shoes.
  - only two (2) riders at a time.
- This vehicle has adjustable, play seat belts. Please note that the adjustable seat belts are designed to be a play feature only and do not function as protective safety restraints.
- To prevent damaging the motors and gears, teach your child to stop the vehicle before switching between forward and reverse. Do not tow anything behind the vehicle or overload it. Do not exceed the maximum weight capacity of 130 lb. (59 kg).
- For safety reasons, your vehicle has been pre-set so that it will only operate at low speed. **You must remove the high speed lock-out screw to allow operation of the vehicle at high speed**. Please see page 22 for detailed instructions.
- If you have any questions about your Power Wheels® vehicle, please call our toll-free service lines at **1-800-348-0751** from 8 AM to 6 PM (EST) Monday through Friday. Trained customer service representatives are available to take your call in English or French. Habla Español? Si usted tiene alguna pregunta ó necesita asistencia llame gratis **1-800-348-0755** para los Estados Unidos. Tenemos representantes que hablan español para atender su llamada.
- For your convenience, Power Wheels® maintains an **independently owned and operated** Authorized Service Center Network with more than 400 authorized, service centers nationwide. The authorized service centers will repair or replace parts under warranty at no extra charge, and can perform non-warranty repairs for a minimal charge. To find the authorized service center nearest you, visit us on-line at **www.powerwheels.com** or call **1-800-348-0751**.
- If you would like to register your vehicle, please visit us on-line at **www.powerwheels.com**.

# B

## Warnings and Cautions

### ELECTRICAL HAZARD

#### **WARNING**

- Battery can fall out and injure a child if vehicle tips over. Always use battery clamp.
- **PREVENT FIRE**
  - Never modify the electrical system. Alterations could cause a fire resulting in serious injury and could also ruin the electrical system.
  - Use of the wrong type battery or charger could cause a fire or explosion resulting in serious injury.
  - Use of Power Wheels® components in products other than Power Wheels® vehicles could cause overheating, fire or explosion.
- The battery must be handled by adults only. The battery is heavy and contains sulfuric acid (electrolyte). Dropping the battery could result in serious injury.
- Never allow children to charge the battery. Battery charging must be done by adults only. A child could be injured by the electricity involved in charging the battery.
- Read the safety instructions on the battery.
- Examine the battery, charger and their connectors for excessive wear or damage each time you charge the battery. If damage or excessive wear is detected, do not use the charger or the battery until you have replaced the worn or damaged part.
- **HOT** motors. Handle carefully.

### RIDING HAZARD

#### **WARNING**

- **Prevent Injuries and Deaths**
  - Direct Adult Supervision Required
  - Keep Children Within Safe Riding Areas.  
These areas must be:
    - away from swimming pools and other bodies of water to prevent drownings
    - generally level to prevent tipovers
    - away from steps, driveways, cars, roads and alleys.

#### **CAUTION**

- In the unassembled state, this package contains small parts. Adult assembly is required.
- Use the charger in dry locations only.

# C

## Parts

- If you experience a problem with this product, or are missing a part, please call us at **1-800-348-0751**, rather than return this product to the store.
- Please identify all parts before assembly and save all packaging material until assembly is complete to ensure that no parts are discarded.
- Metal parts have been coated with a lubricant to protect them during shipment. Wipe all metal parts with a paper towel to remove any excess lubricant.

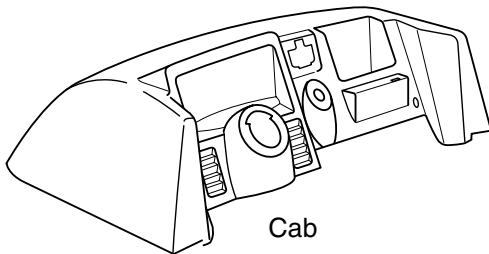
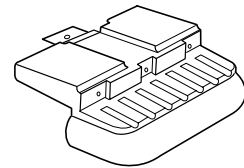
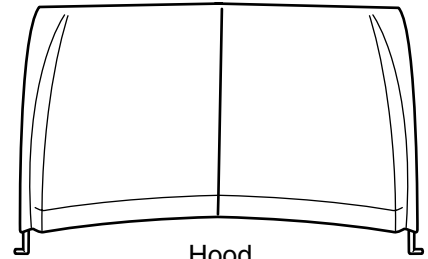
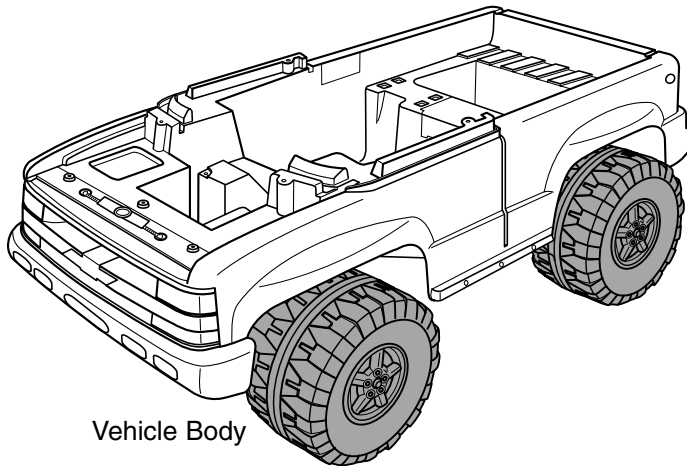

Steering Wheel Cap

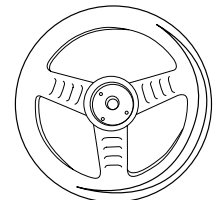
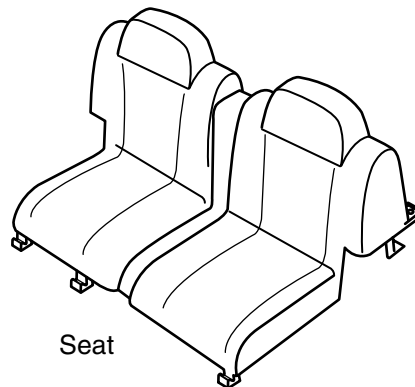

Antenna

# Parts

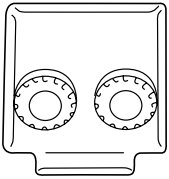

Knob Plate

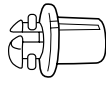

Dashboard Knob – 2

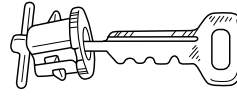

Key Assembly



Cap

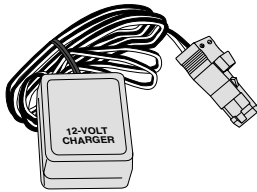

12 Volt Charger

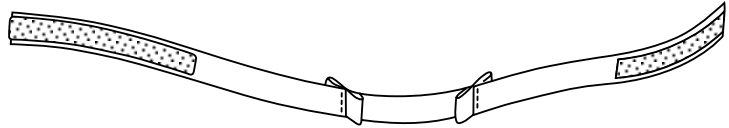

Long Seat Belt Strap



Wire Clip



Short Seat Belt Strap - 2

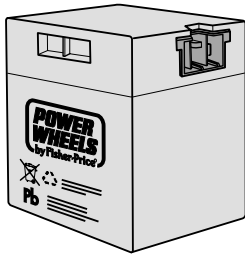

12 Volt Battery



Battery Clamp Cap

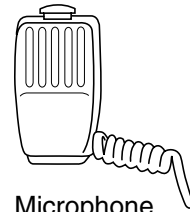

Microphone

**Not Shown:** Label Sheet - 2

**Note:** Tighten and loosen all screws with a Phillips screwdriver. Do not over-tighten.

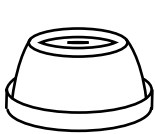

.354 Cap Nut - 2\*

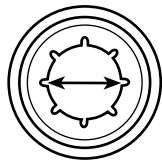

#8 x 3/4" Screw – 11\*



#8 - 18 x 1" Screw – 2



#8 - 18 x 1 3/4" Screw – 2

**All Shown Actual Size**

\*For your convenience, an extra #8 x 3/4" screw and an extra .354 cap nut have been included.

# D

## Parts Diagram

**Note:** Some parts shown are assembled on both sides of the vehicle.

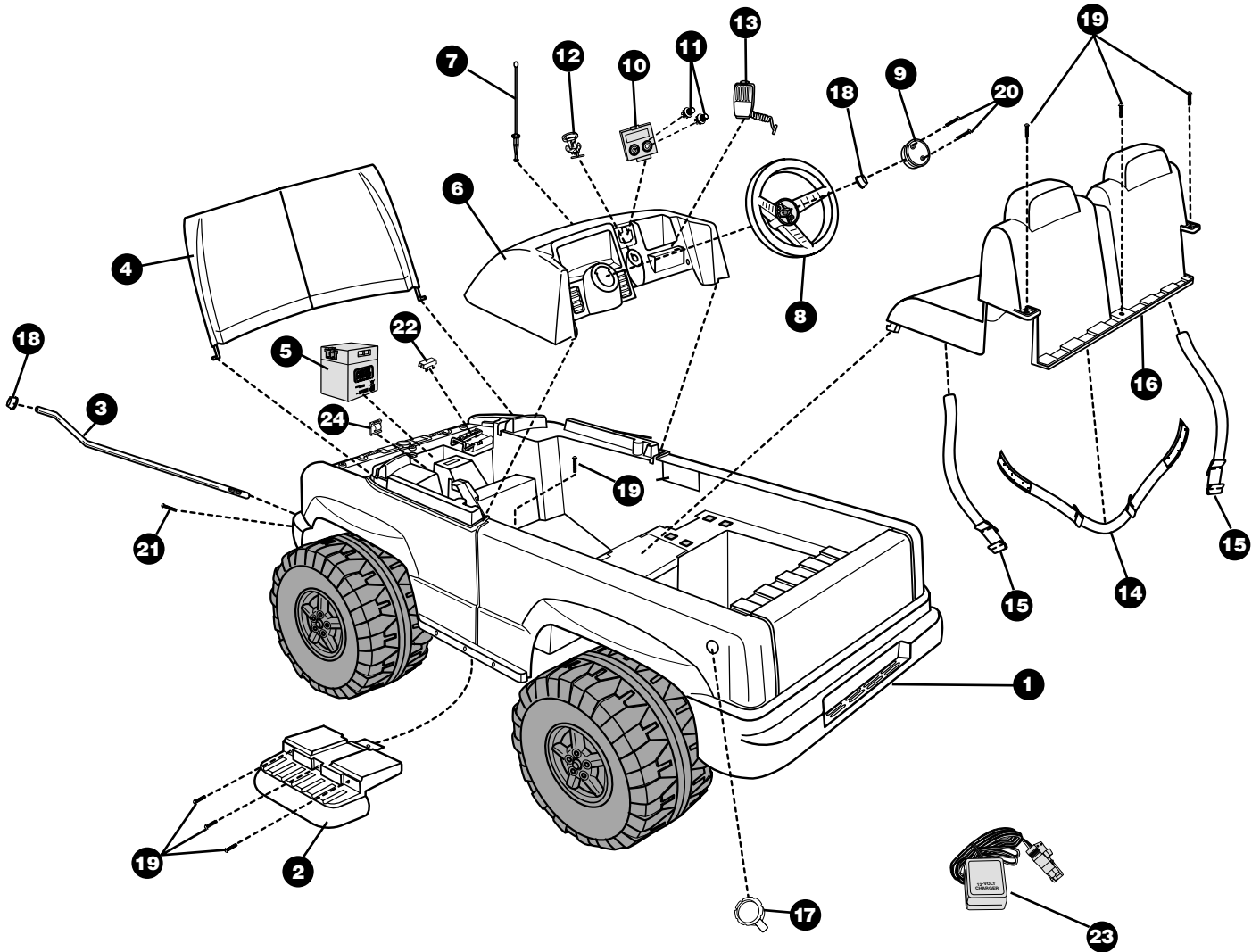

- |                                |                               |                                |
|--------------------------------|-------------------------------|--------------------------------|
| 1. Vehicle Body                | 10. Knob Plate                | 19. #8 x 3/4" Screw - 11       |
| 2. Running Board (L and R) - 2 | 11. Dashboard Knob - 2        | 20. #8 - 18 x 1" Screw - 2     |
| 3. Steering Column             | 12. Key Assembly              | 21. #8 - 18 x 1 3/4" Screw - 2 |
| 4. Hood                        | 13. Microphone                | 22. Battery Clamp Cap          |
| 5. 12 Volt Battery             | 14. Long Seat Belt Strap      | 23. 12 Volt Charger            |
| 6. Cab                         | 15. Short Seat Belt Strap - 2 | 24. Wire Clip                  |
| 7. Antenna                     | 16. Seat                      |                                |
| 8. Steering Wheel              | 17. Cap                       |                                |
| 9. Steering Wheel Cap          | 18. .354 Cap Nut - 2          |                                |

**Part Not Shown:**  
Label Sheet - 2

**ELECTRICAL HAZARD** **WARNING**

- Battery can fall out and injure a child if vehicle tips over. Always use battery clamp.
- **PREVENT FIRE**
  - Never modify the electrical system. Alterations could cause a fire resulting in serious injury and could also ruin the electrical system.
  - Use of the wrong type battery or charger could cause a fire or explosion resulting in serious injury.
  - Use of Power Wheels® components in products other than Power Wheels® vehicles could cause overheating, fire or explosion.
- The battery must be handled by adults only. The battery is heavy and contains sulfuric acid (electrolyte). Dropping the battery could result in serious injury.
- Never allow children to charge the battery. Battery charging must be done by adults only. A child could be injured by the electricity involved in charging the battery.
- Read the safety instructions on the battery.
- Examine the battery, charger and their connectors for excessive wear or damage each time you charge the battery. If damage or excessive wear is detected, do not use the charger or the battery until you have replaced the worn or damaged part.

# Battery Charging



## CAUTION

Use the charger in dry locations only.

### About Thermal Fuses

Your Power Wheels® 12 volt battery is equipped with a built-in thermal fuse. The thermal fuse is a self-resetting safety device which automatically “trips” and shuts down operation of the vehicle if the vehicle is overloaded or the driving conditions too severe. Once a fuse has “tripped”, it will automatically reset itself after approximately 25 seconds and allow the vehicle to resume normal operations. To avoid repeated automatic shutdowns, do not overload the vehicle by exceeding the 130 lb. (59 kg) maximum weight capacity or by towing anything behind the vehicle. Avoid severe driving conditions, such as driving up steep slopes or running into fixed objects, which can cause the wheels to stop spinning while power is still being supplied to the motors. Make sure your child stops the vehicle before switching speeds or direction.

If a thermal fuse in a battery continually trips under normal driving conditions, please contact your local Power Wheels® authorized service center. For the location of the authorized service center nearest to you, please visit us on-line at [www.powerwheels.com](http://www.powerwheels.com).

### IMPORTANT!

- **Your new battery must be charged for at least 18 hours before you use it in your vehicle for the first time.**
- We recommend that you start charging your battery before beginning assembly of your new vehicle.
- The battery must be upright while charging.
- The charger is not a toy.
- Do not short circuit the battery.
- If your battery is old and will not accept a charge, do not leave it in the vehicle. Always remove a dead battery from the vehicle.
- Before charging the battery, examine the battery case for cracks and other damage which may cause sulfuric acid (electrolyte) to leak during the charging process. If damage is detected, do not charge the battery or use it in your vehicle. Battery acid is very corrosive and can cause severe damage to surfaces it contacts.
- Do not charge the battery on a surface (such as kitchen countertops) which could be damaged by the acid contained inside the battery. Take precautions to protect the surface on which you charge your battery.
- Use only a Power Wheels® 12 volt charger with type “12V” connector (120 VAC 60 Hz 28W with an output of 12 VDC 1200mA) to charge your Power Wheels® rechargeable 12 volt battery.
- Once installed, you do not need to remove the battery from your vehicle to recharge it.

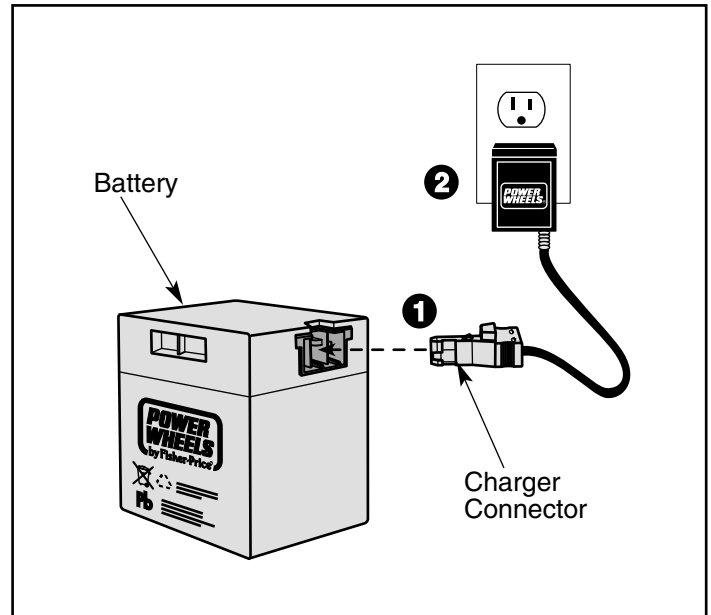

- Plug the charger connector into the battery **1**.
- Plug the charger into a standard wall outlet **2**.

**Note:** If power flow to the wall outlet is controlled by a switch, make sure the switch is “ON”.

- Before first-time use, charge the battery for **at least 18 hours**. Never charge the battery longer than 30 hours.
- Recharge the battery for at least 14 hours after each use of your vehicle. Do not charge the battery longer than 30 hours.
- Once the battery is charged, pull the charger connector firmly to disconnect it from the battery. Unplug the charger from the wall outlet. The battery is now ready to be installed in your vehicle. Please see the Battery Installation section on page 18 for detailed instructions on installing your battery. If your battery is already installed in your vehicle, simply re-connect the motor harness connector to the battery, lower and fasten the hood.

### **WARNING**

Children can be harmed by small parts, sharp edges and sharp points in the vehicle's unassembled state, or by electrical items. Care should be taken in unpacking and assembly of the vehicle. Children should not handle parts, including the battery, or help in assembly of the vehicle.

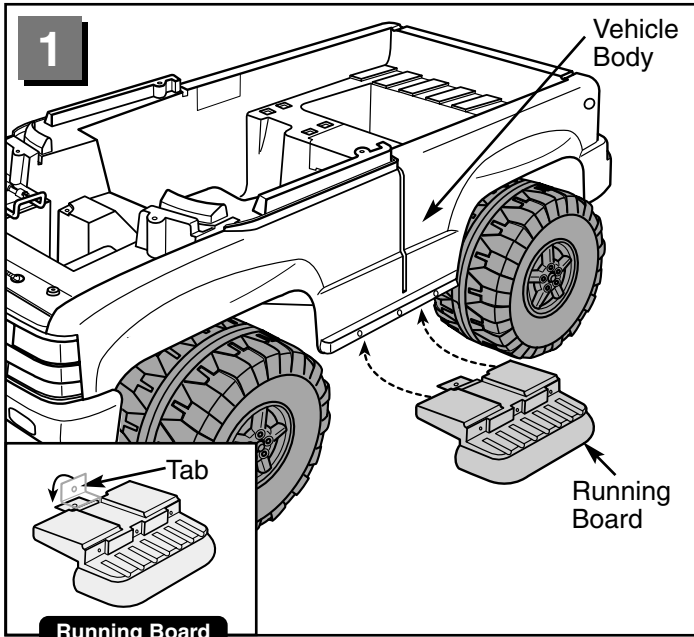

- Bend the tab on a running board **down** (see inset).
- While holding the tab down, fit the running board under the side edge of the vehicle body.

**Hint:** You may need to pull gently on the side of the vehicle body to fit the running board in place.

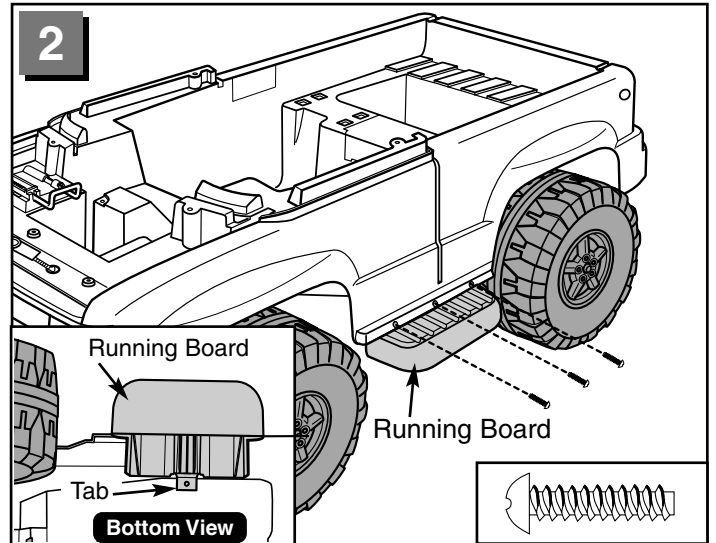

- Make sure that the three holes in the running board are aligned with the three holes in the vehicle body and that the flat side of the running board tab contacts the underside of the vehicle body (see inset).
- Insert three #8 x 3/4" screws into the holes in the vehicle body and tighten.

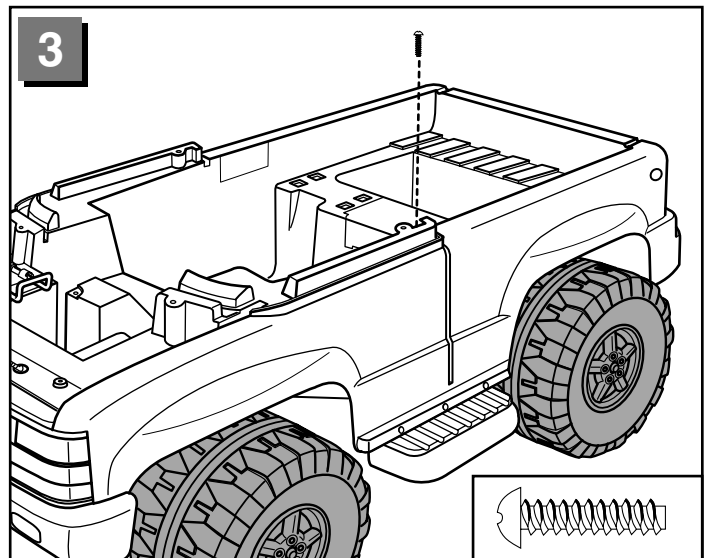

- Make sure the hole in the running board tab is aligned with the hole in the floor of the vehicle body. Insert a #8 x 3/4" screw through the hole in the vehicle body floor and into the running board tab. Tighten the screw.
- Repeat assembly steps 1 - 3 to assemble the other running board to the other side of the vehicle.

# Assembly

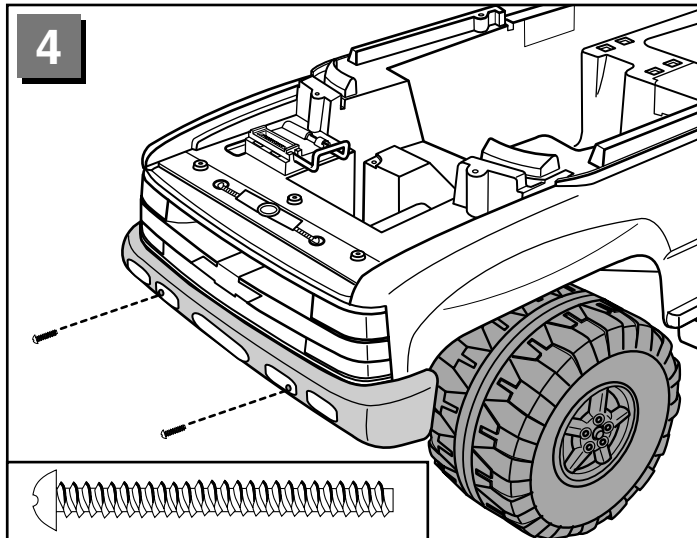

- Insert two #8-18 x 1<sup>3</sup>/<sub>4</sub>" screws into the holes in the front bumper and tighten.

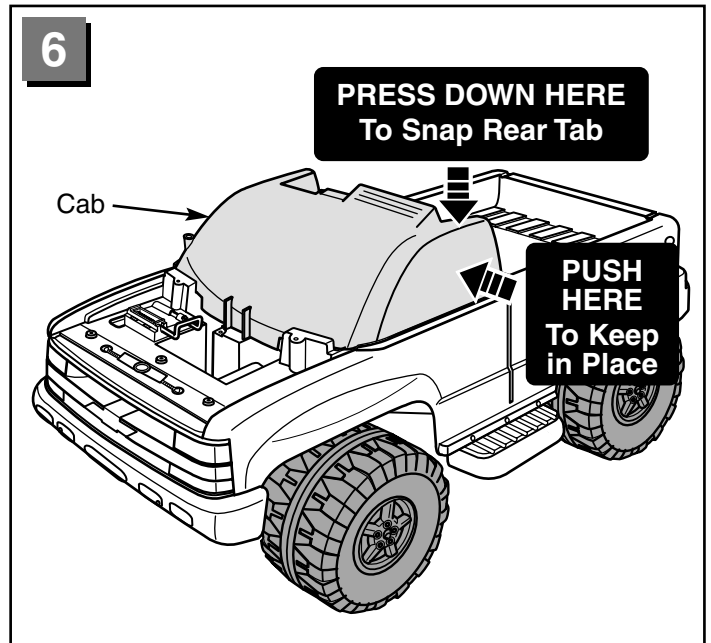

- Press firmly above one of the rear tabs to snap it into the slot in the vehicle body.

**IMPORTANT!** While snapping the rear tab into the slot, push on the side of the cab to prevent it from bowing. Make sure that the cab side tabs stay aligned in the vehicle slots.

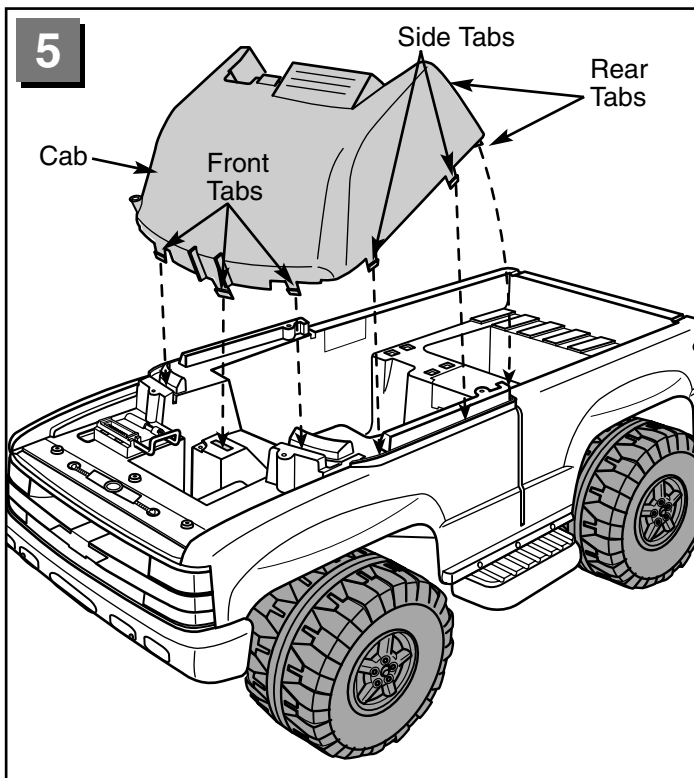

- Position the three front tabs on the cab into the slots in the vehicle body. **DO NOT snap the front tabs into the slots in the vehicle body.**
- Position the side and rear tabs on both sides of the cab in the corresponding slots the vehicle body. **DO NOT snap the side and rear tabs into the slots in the vehicle body.**

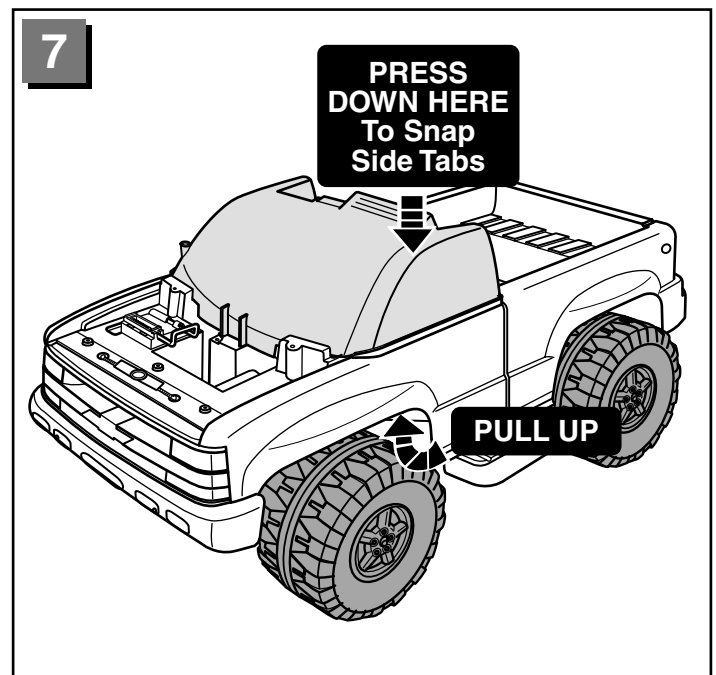

- Press down above the cab side tabs while pulling up on the front wheel well to snap the side tabs into the slots.
- Repeat steps 6 and 7 to snap the rear and side tabs on the other side of the cab into the slots in the vehicle body.

# Assembly

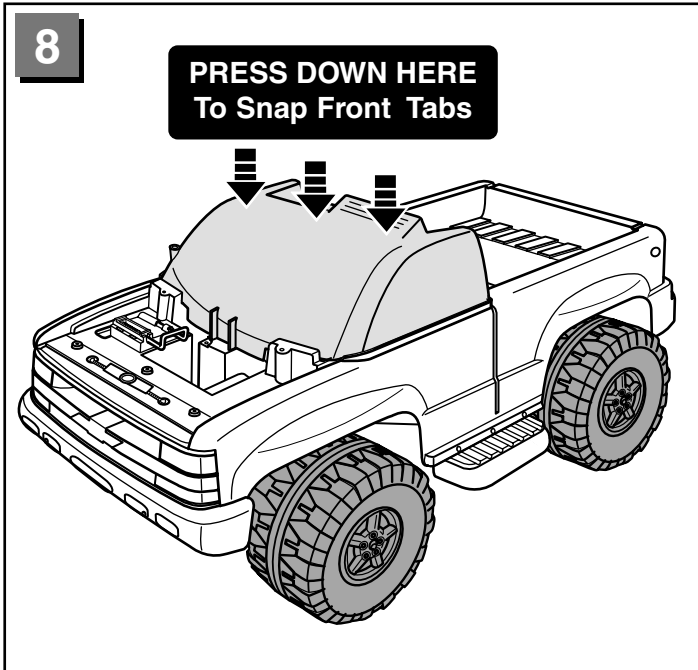

- Press firmly above each of the front tabs to snap them into the slots in the vehicle body.

**IMPORTANT! Check each front, side and rear tab to make sure the tabs are properly secured in the slots in the vehicle body.**

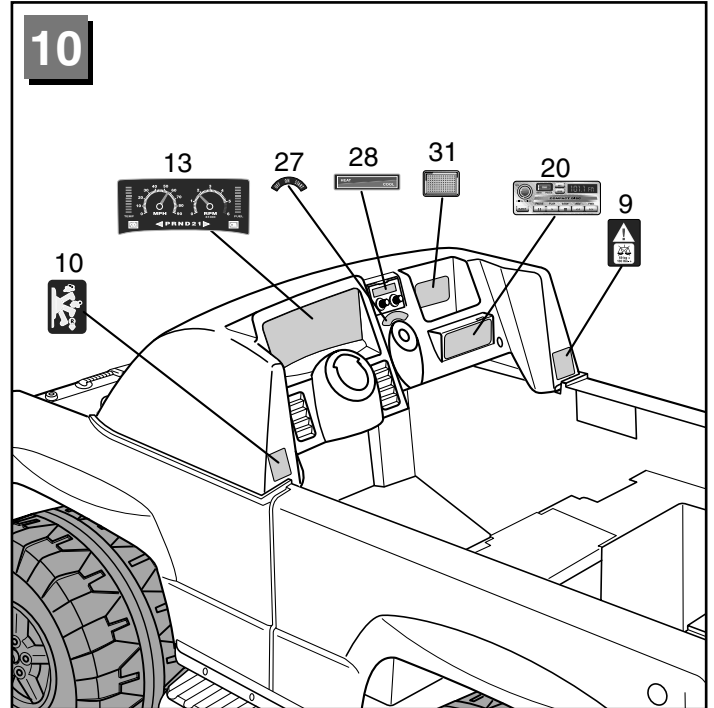

- Before applying labels to the dash, wipe the dash with a clean, dry cloth to make sure it is free of dirt and oils. Make sure your hands are clean and dry.
- Apply labels as shown. For best results, avoid repositioning a label once it has been applied.

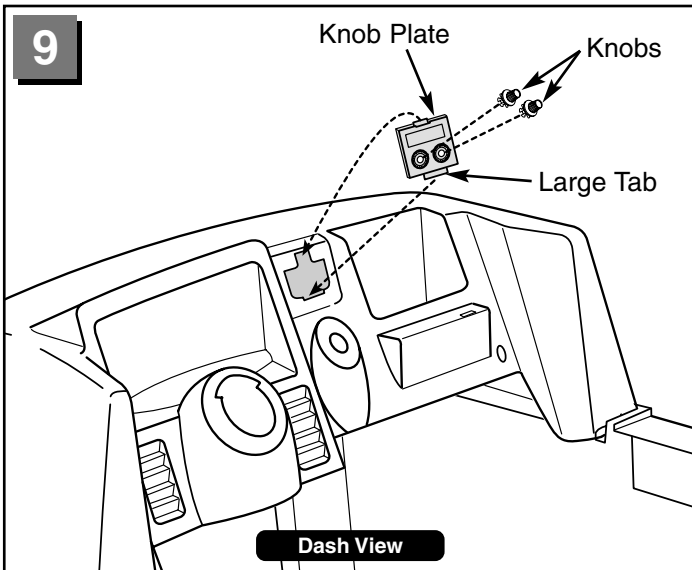

- Position the knob plate with the large tab down.
- Fit the large tab on the knob plate into the bottom of the square opening on the dash, as shown.
- Press near the top of the knob plate to “snap” it into the dash.
- Fit the knobs into the holes in the knob plate and press firmly to “snap” them into the dash.

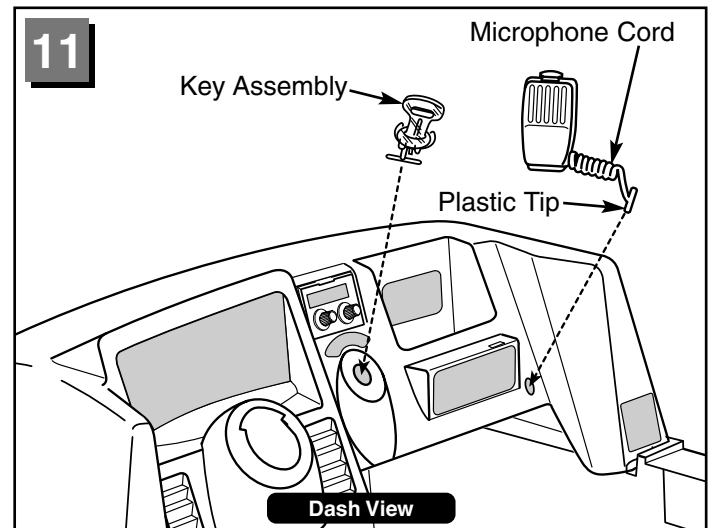

- Bend the plastic tip of the microphone cord so that it forms a “T”.
- Fit the plastic tip at the end of the microphone cord through the small oval hole in the dash. Pull up gently on the microphone cord to make sure the plastic tip is secure under the dash.
- Fit the microphone to the dash.
- Fit the key assembly into the hole below the knob plate and press firmly to “snap” it into the dash.

# Assembly

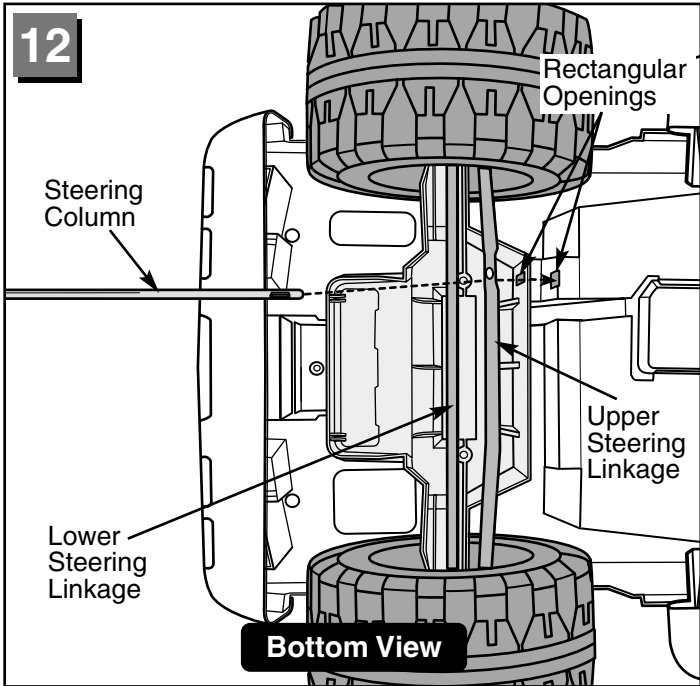

- Position the vehicle body on its side.
- From the underside of the vehicle body, fit the straight end of the steering column between the upper and lower steering linkages and through the rectangular openings in the front axle assembly and vehicle body.
- Continue to slide the steering column into the passenger compartment.

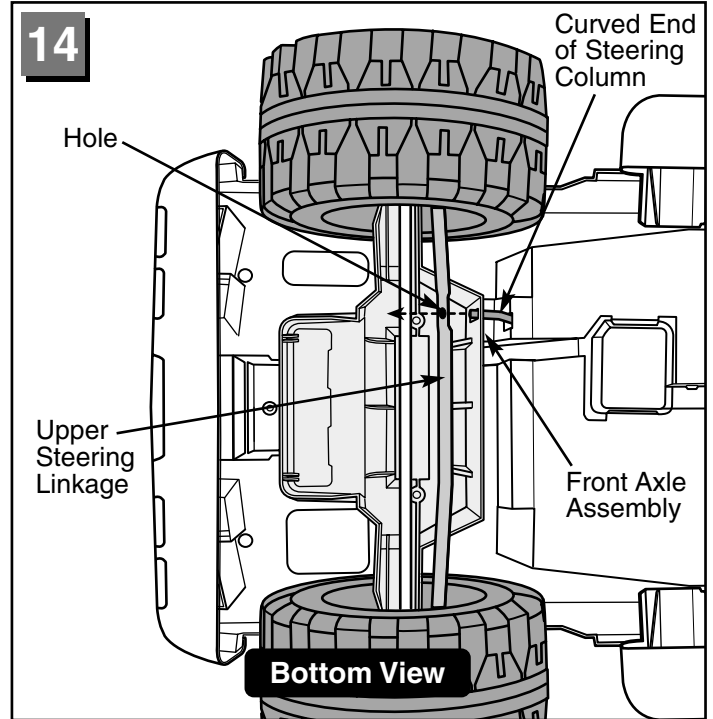

- From the underside of the vehicle body, fit the curved end of the steering column into the hole in the upper steering linkage.
- Hint: You may need to rotate the steering column to fit it into the hole.*

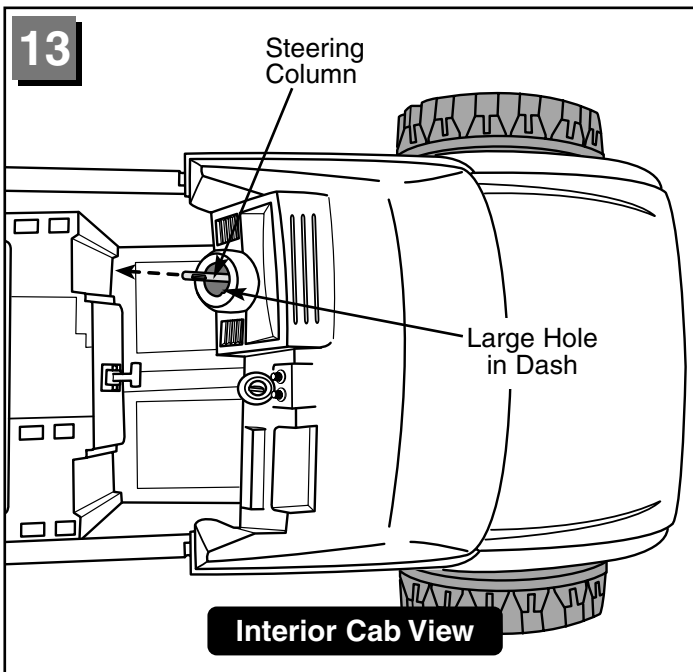

- Fit the end of the steering column out through the large hole in the dash.

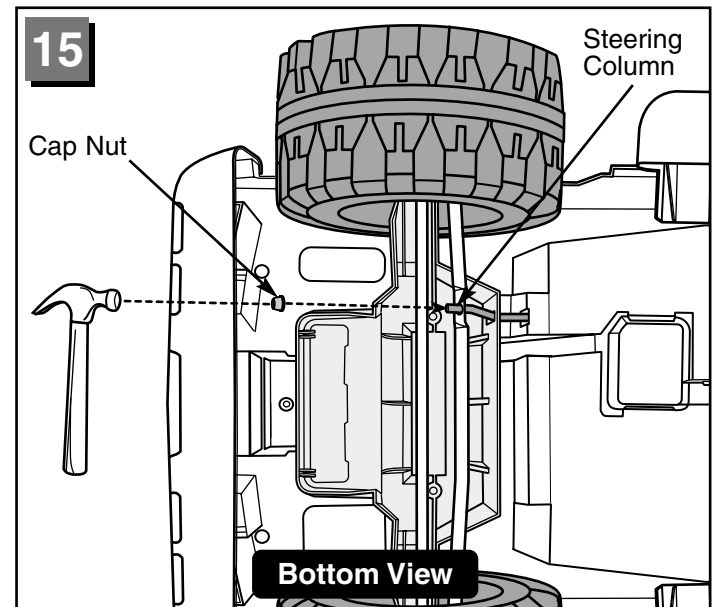

- Fit a cap nut on the end of the steering column.
  - Tap the cap nut with a hammer to secure it on the end of the steering column.
- Hint: You may want the help of another adult to support the steering column while you tap the cap nut with the hammer.*
- Position the vehicle body upright.

# Assembly

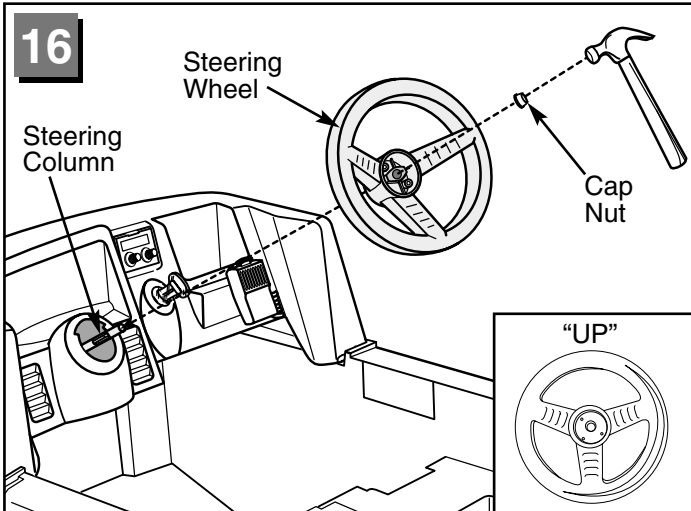

- Position the steering wheel upright, so that the spokes form a "Y".
- Fit the steering wheel onto the steering column. Make sure the neck of the steering wheel fits into the hole in the dash.
- Fit a cap nut onto the end of the steering column.
- Tap the cap nut with a hammer to secure it on the end of the steering column.

**Hint:** You may want the help of another adult to support the steering column while you tap the cap nut with the hammer.

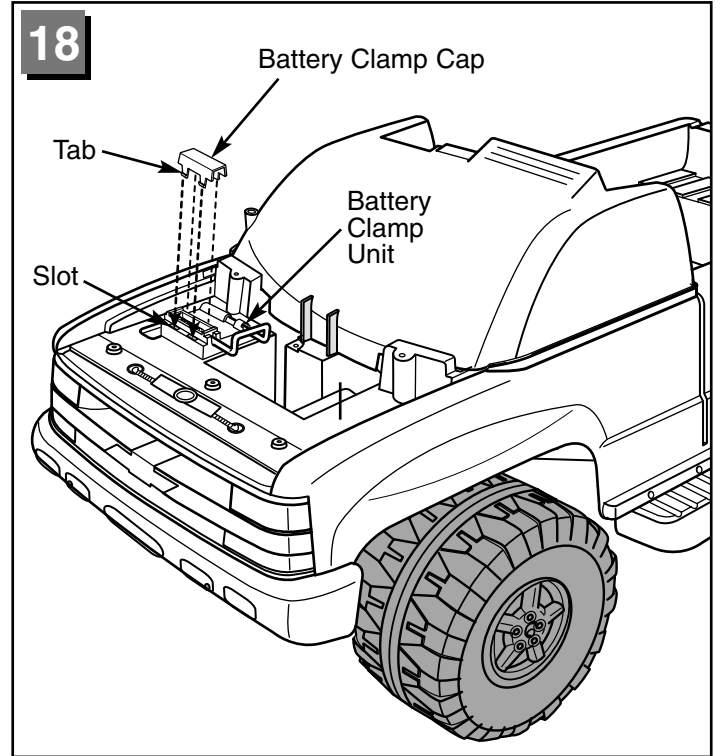

- Fit the tabs on the battery clamp cap into the slots in the battery clamp unit.
- Press firmly to "snap" the battery clamp cap tabs in the battery clamp unit slots.

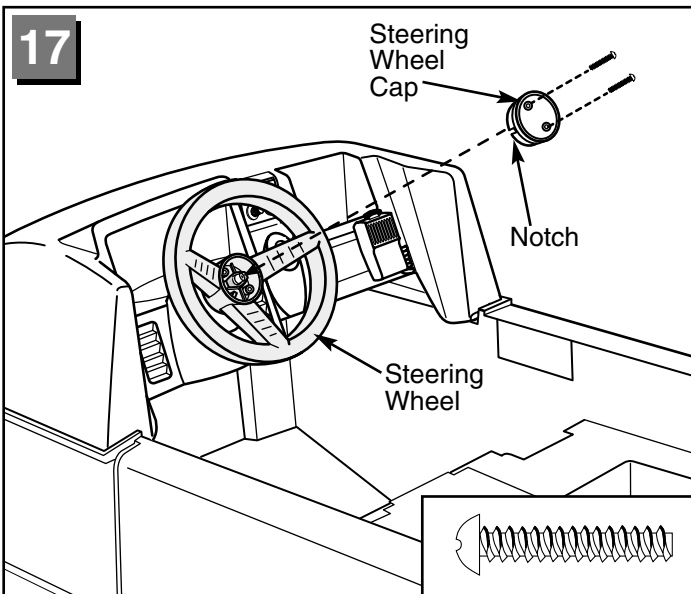

- Align the notch in the side of the steering wheel cap with the tab in the center of the steering wheel. Fit the steering wheel cap into the steering wheel.
- Insert two #8-18 x 1" screws into the steering wheel cap and tighten.

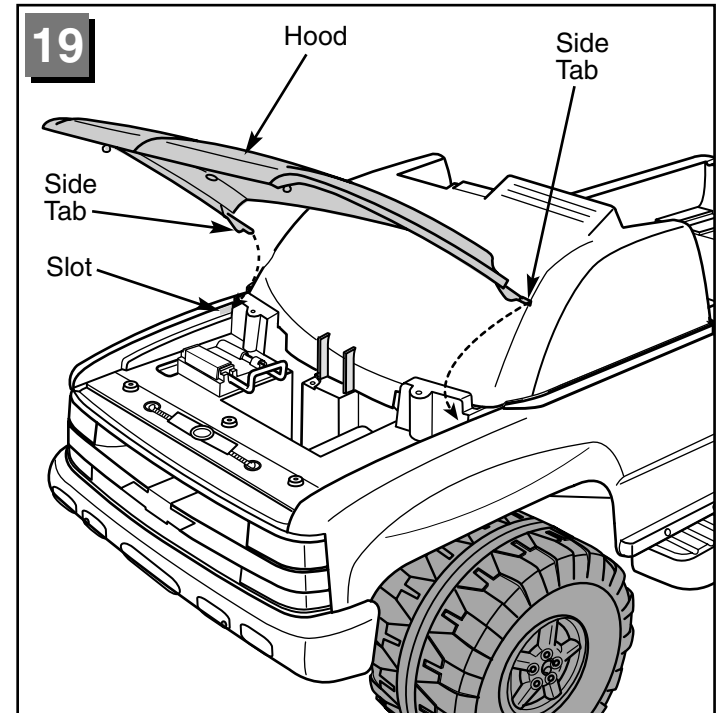

- Fit one of the side tabs on the hood into the slot in the vehicle body.
- While bending the hood slightly, fit the other side tab into the corresponding slot on the vehicle body.

# Assembly

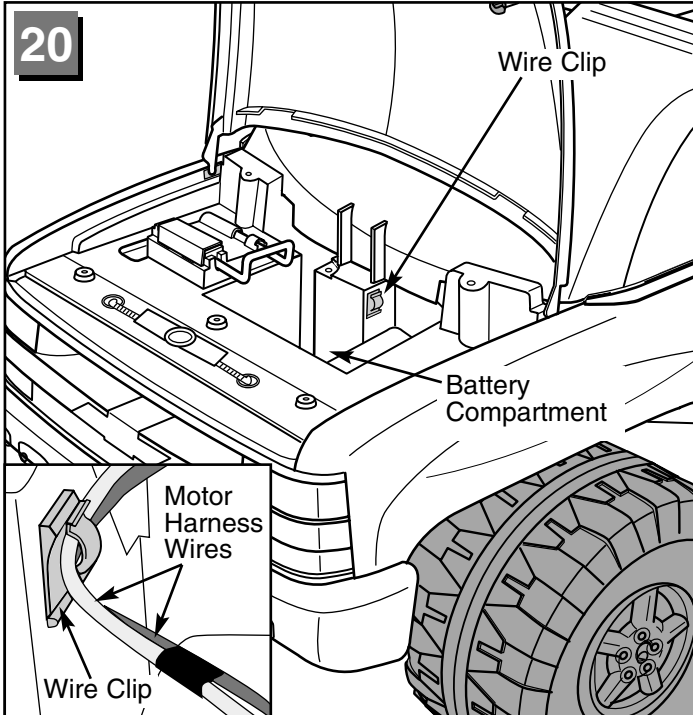

- Remove the backing from the wire clip. Dispose of the backing properly.
- Press the wire clip into place in the battery compartment, as shown.
- Fit the motor harness wires into the wire clip, as shown.

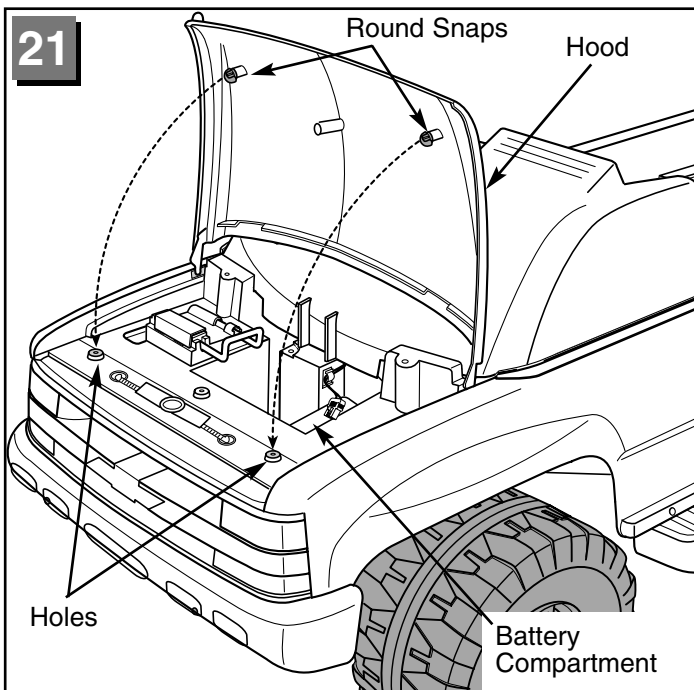

- Lower the hood, making sure to align the round snaps on the underside of the hood with the holes near the battery compartment.
- Press firmly on the top of the hood above each snap to fasten the hood. (To open the hood, please see the instructions on page 18, step 1.)

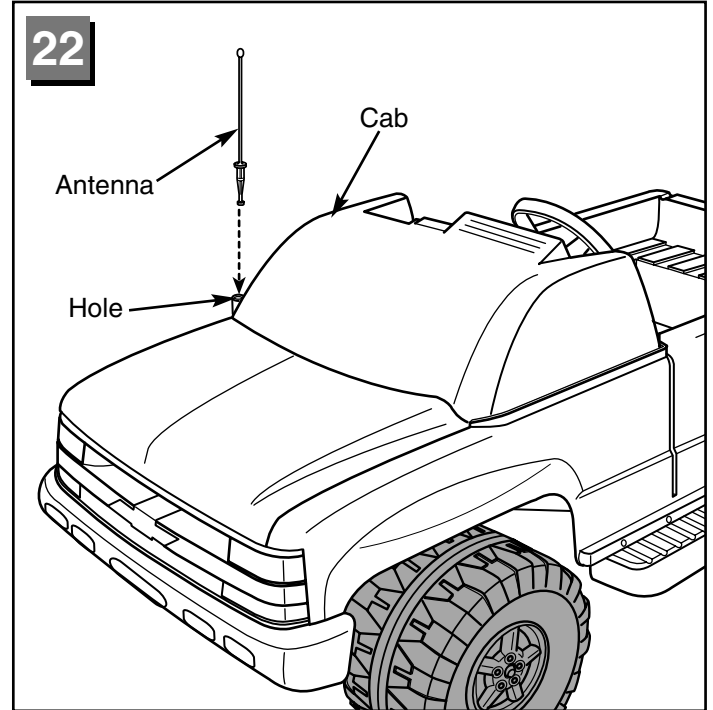

- Fit the tapered end of the antenna into the hole in the front of the cab.
- Press firmly to snap the antenna into the hole.

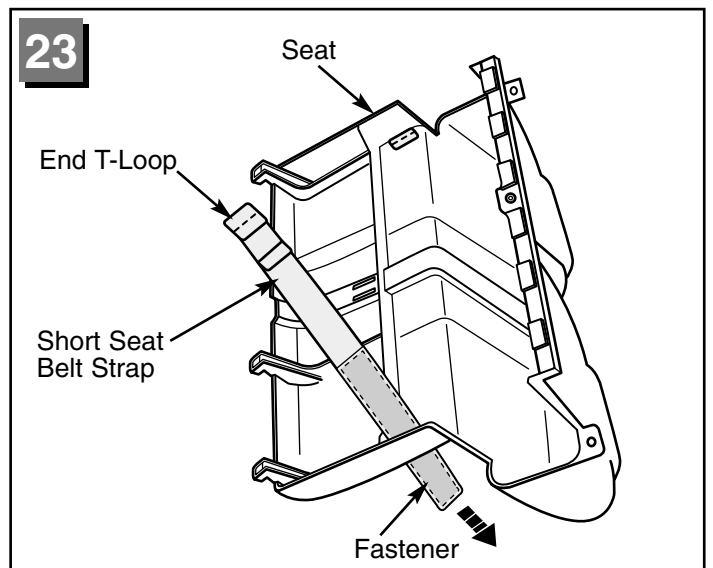

- Position the seat upside down.
- Insert the fastener end of a short seat belt strap through one of the slots near the outer edge of the seat. Make sure the side of the seat belt with the fastener faces the outer edge of the seat.
- Pull the short seat belt strap completely through the slot until the end T-loop at the opposite end of the belt catches against the slot. (You will pull one T-loop through the slot.)
- Repeat this procedure to assemble the other short seat belt strap to the seat.

# Assembly

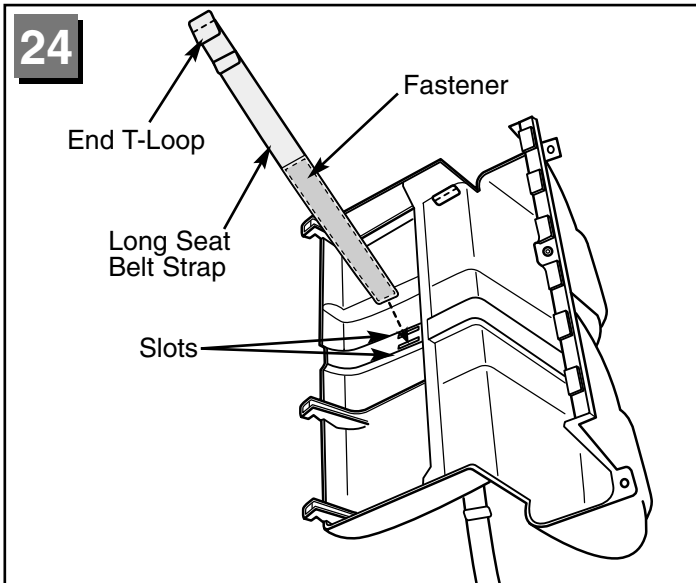

- Insert the fastener end of a long seat belt strap through a slot in the center of the seat. Make sure that the fastener faces the outer edge of the seat.
- Pull the long seat belt strap completely through the slot until the T-loop at the opposite end of the belt catches against the slot. (You will pull one T-loop through the slot.)
- Repeat this procedure to assemble the other long seat belt strap to the seat.

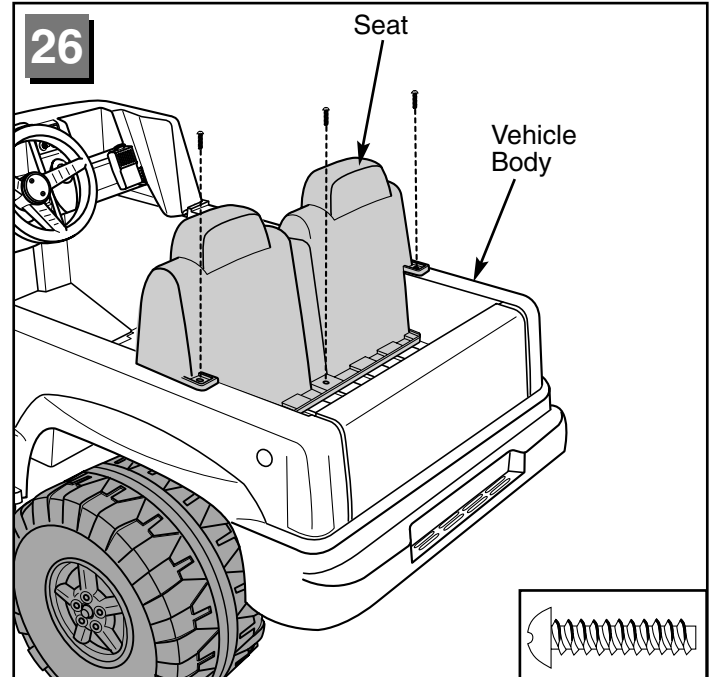

- Once you have selected the appropriate seat position and inserted the seat tabs into the slots in the vehicle body, align the holes in the back of the seat with the holes in the vehicle body.
- Insert three #8 x 3/4" screws into the holes in the seat and tighten.

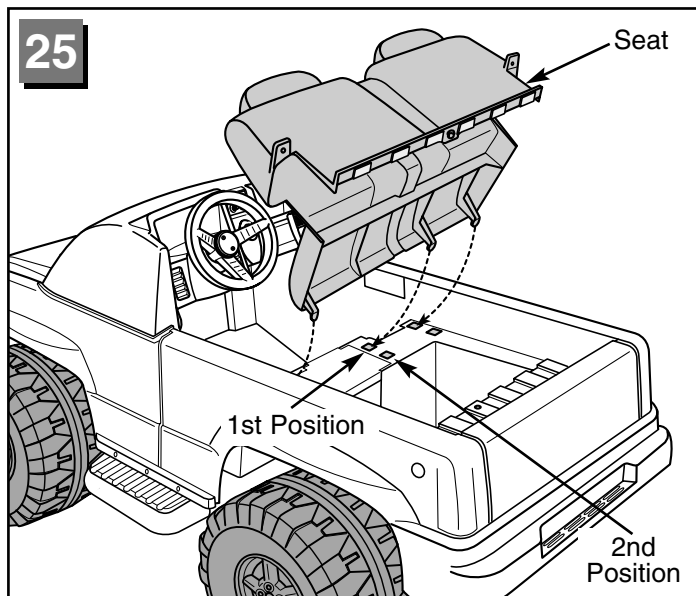

**Note:** The seat can be assembled in either of two positions for your child's comfort.

- Position the seat upright.
- Fit the three tabs on the front of the seat into either the 1st or 2nd set of square openings in the vehicle body. Seat your child in the vehicle and check your child's foot to pedal distance to select the proper seat position for your child. Reposition the seat, if necessary.

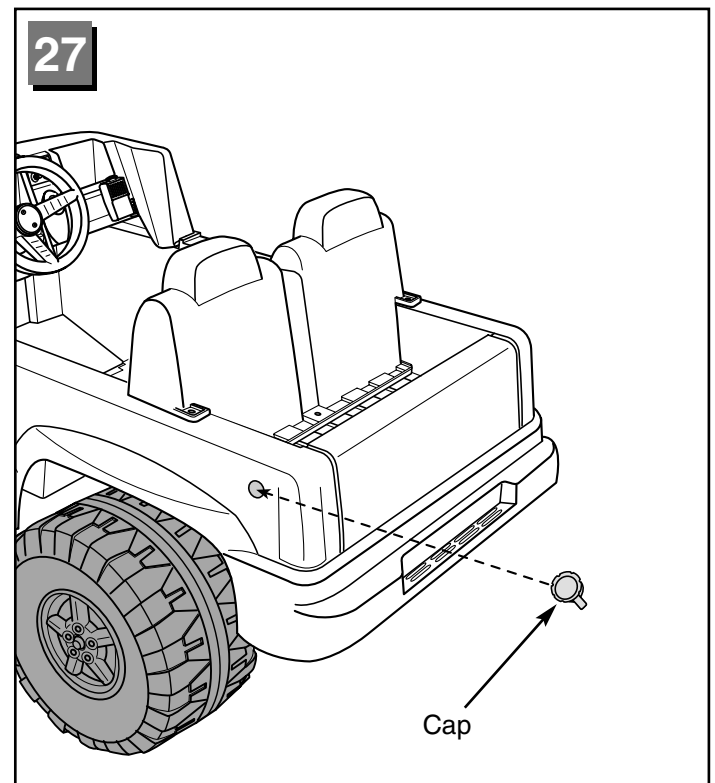

- Fit the cap into the hole in the side of the vehicle body.

# G

## Label Decoration

Proper label application will help to keep the labels looking their best! When applying labels, keep the following guidelines in mind:

- Wash your hands before applying the labels.
- Before applying the labels, wipe the surface of the vehicle with a clean, dry cloth to remove any dust or oils.
- Place the labels exactly as shown in the illustrations.
- For best results, avoid repositioning a label once it has been applied to the vehicle.
- **After applying a label, rub the label firmly with a clean, dry cloth to make sure the label is adhered to your vehicle. Start at the center of a label, and smooth towards the outer edges to remove air bubbles.**

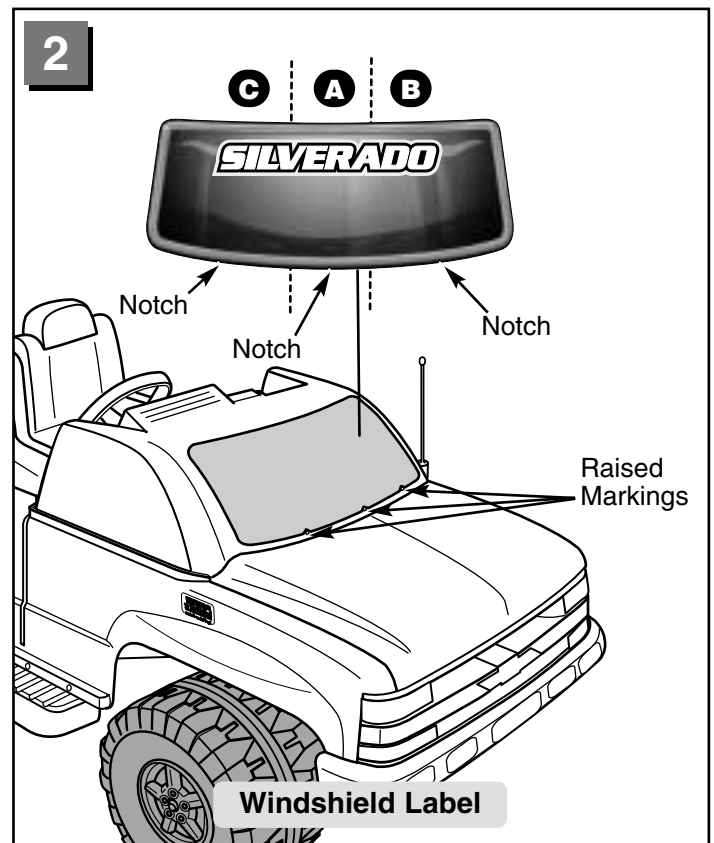
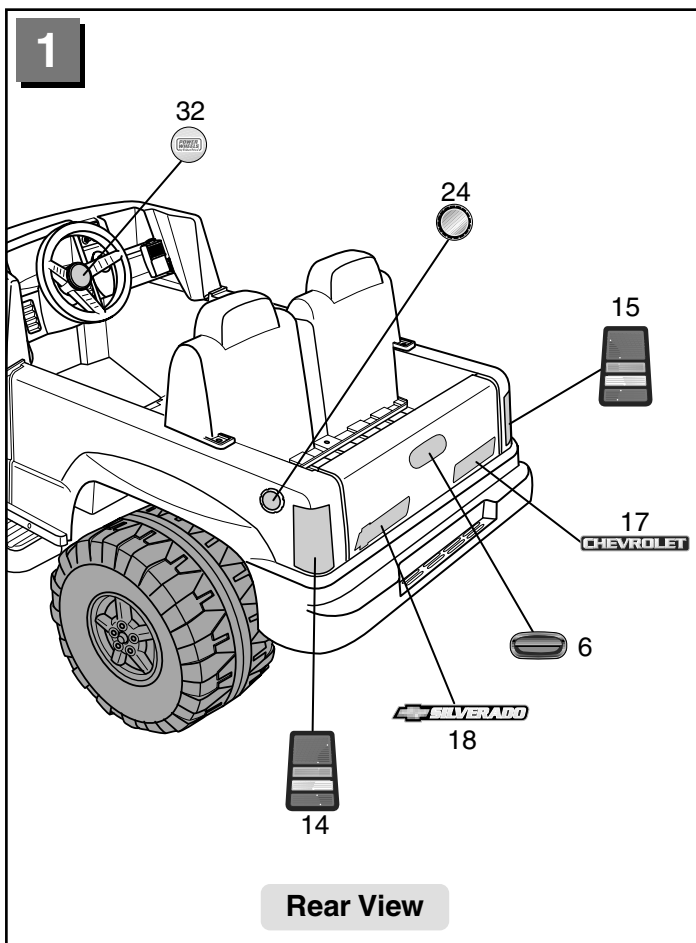

Follow these special instructions carefully to decorate the windshield!

- A** • Peel **only the center strip** off the back of the windshield label.
- Note the three notches at the bottom of the windshield label. Beginning with the notch in the center of the label, align all three notches with the raised markings on the vehicle body near the bottom of the windshield.
- With the notch in the center of the label aligned with the raised marking in the center of the windshield, apply the center section of the windshield label to the vehicle. Smooth the label from the center, outwards.
- B** • Remove the backing from one side of the label.
- Keep the notch at the bottom of the label aligned with the mark on the vehicle body while applying the label to the vehicle. Smooth the label from the center, outwards.
- C** • Remove the remaining backing from the other side of the label.
- Keep the notch at the bottom of the label aligned with the mark on the vehicle body while applying the label to the vehicle. Smooth the label from the center, outwards.

# Label Decoration

3

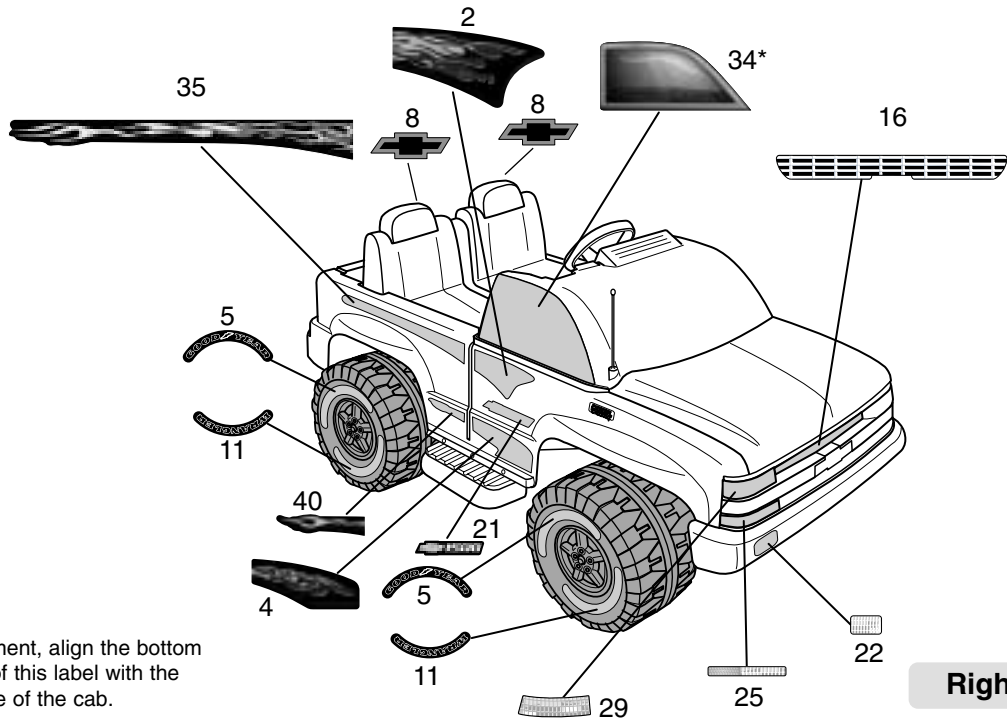

Right Side View

\* For proper placement, align the bottom and back edges of this label with the guides on the side of the cab.

4

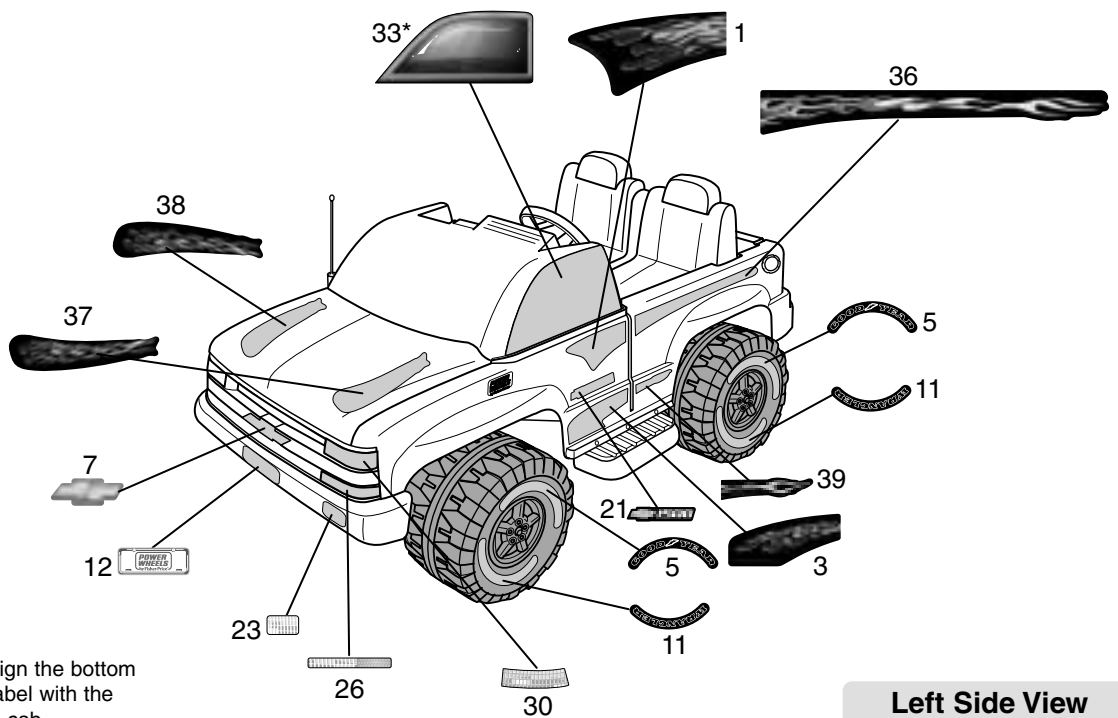

Left Side View

\* For proper placement, align the bottom and back edges of this label with the guides on the side of the cab.

**One-time assembly is now complete.**

**IMPORTANT!**

- Please carefully read the owner's information in this manual and teach your child about proper vehicle operation and rules for safe driving before allowing operation of this vehicle.
- For safety reasons, your vehicle has been pre-set so that it will only operate at low speed (2½ mph, maximum). Make sure that your child can safely operate this vehicle at low speed before removing the high speed lock-out screw to allow operation of the vehicle at high speed (5 mph, maximum). **To disconnect high speed lock-out, please see page 22.**

# H

## Battery Installation

**IMPORTANT!** Use only a Power Wheels® 12 volt battery. Use of any other battery will damage your vehicle. Make sure that you charge the battery for at least 18 hours using the enclosed Power Wheels® 12 volt charger before operating your vehicle for the first time. Charge the battery for at least 14 hours after each use of the vehicle. Never charge the battery longer than 30 hours. Failure to follow these instructions may damage your battery and will void your warranty.

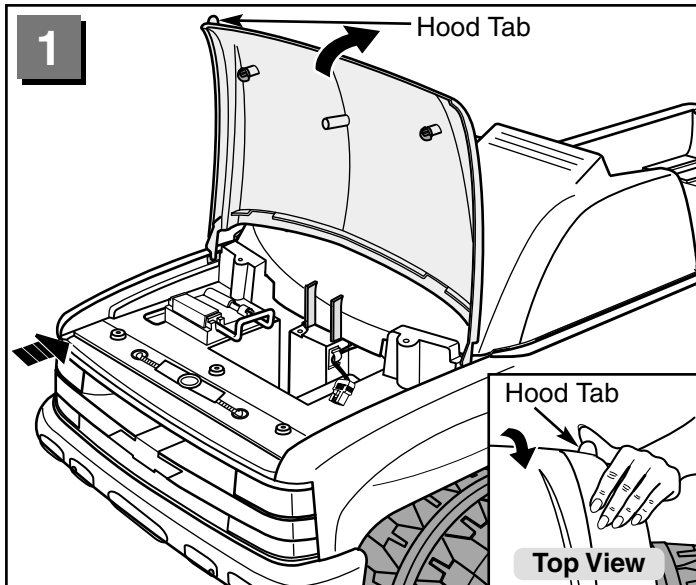

- Lift the hood to access the battery compartment.

**Hint:** Place your hand on the vehicle body and “pop” the hood open by placing your hand under the hood tab (see inset).

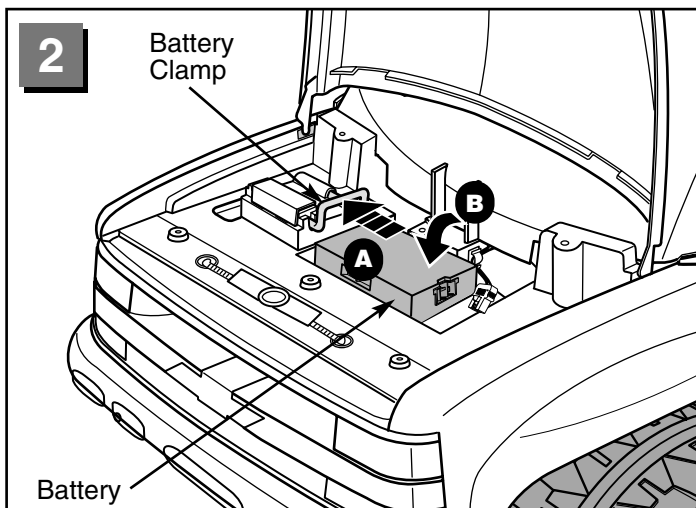

- Press the battery clamp to slide it into the vehicle body **A**.
- While holding the battery retainer clamp, place the battery in the battery compartment **B**. Make sure the battery is upright and positioned between the locator ribs in the bottom of the battery compartment.

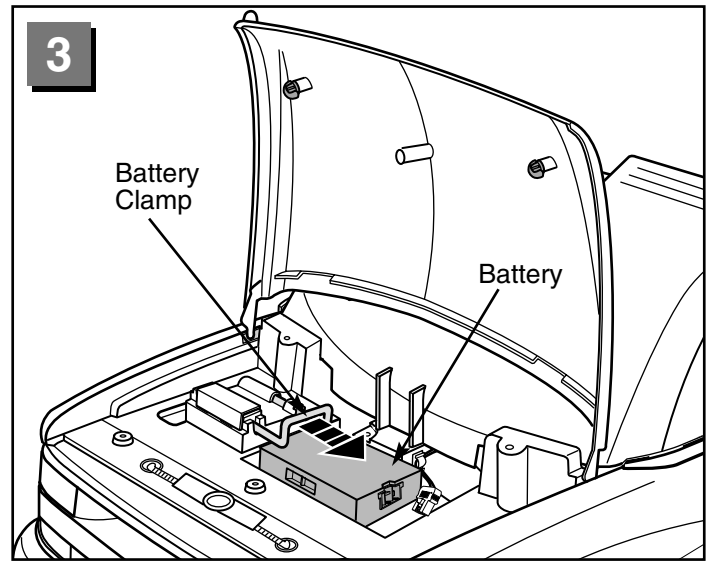

- Release the battery clamp. Make sure the battery clamp slides over the top of the battery. If the battery clamp does not slide over the top of the battery, reposition the battery in the battery compartment (see step 2).

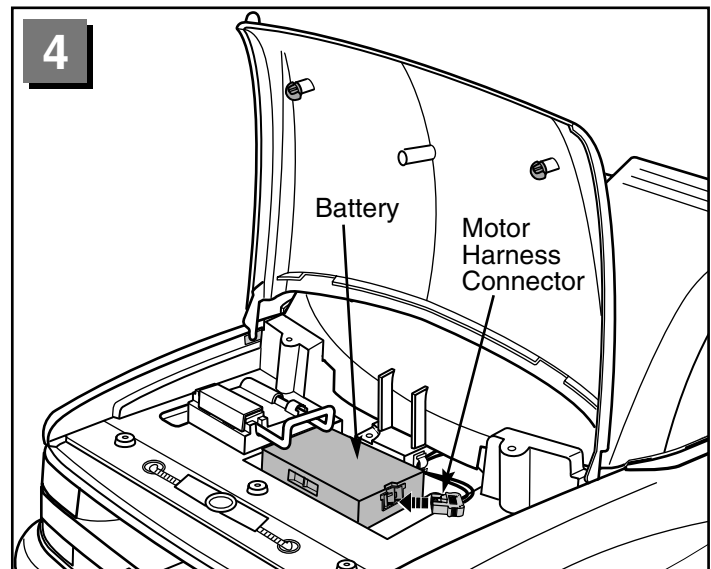

- Plug the motor harness connector into the battery. **Push firmly to make sure the connectors are completely joined.**

**Hint:** To remove a battery from the battery compartment, disconnect the motor harness connector from the battery. Press and hold the battery clamp and lift the battery from the battery compartment.

## Battery Installation

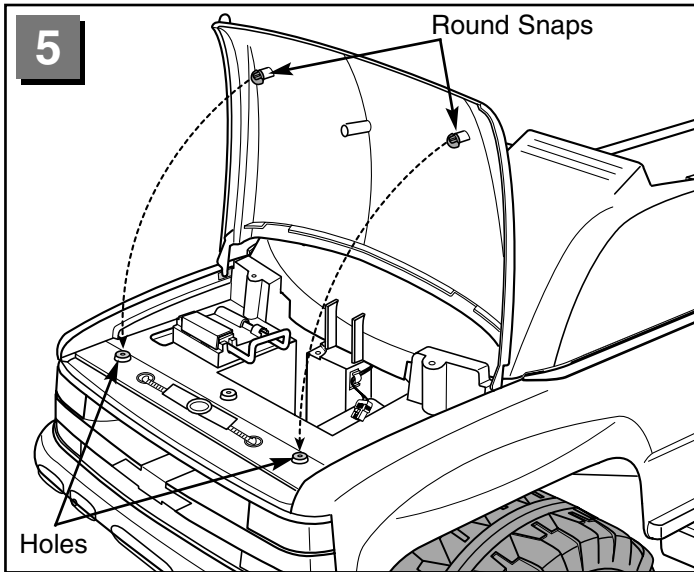

- Lower the hood, making sure to align the round snaps on the underside of the hood with the holes near the battery compartment.
- Press firmly on the top of the hood above each snap to fasten the hood.

## I

## Battery Care and Disposal

### Care

**If a battery leak develops,** avoid contact with the leaking acid and place the damaged battery in a plastic bag. See information below for proper disposal.

**If acid comes in contact with skin or eyes,** flush with cool water for at least 15 minutes and call a physician.

**If acid is internally ingested,** give water, milk of magnesia or egg whites immediately. Never give emetics or induce vomiting. Call a physician.

- Charge a new battery for at least 18 hours before first use. Never charge the battery longer than 30 hours. Overcharging or undercharging the battery may shorten battery life and decrease vehicle running time.
- After the first charge, recharge the battery for at least 14 hours after each use. Never charge the battery longer than 30 hours. Charge the battery after each use, regardless of how long the vehicle was used.
- The battery must be upright while charging.
- Do not allow the battery to run down completely before charging.
- Charge the battery before storing the vehicle.
- Charge the battery at least once per month, even if the vehicle has not been used.

## Battery Care and Disposal

- Leaving the battery in a discharged condition will ruin it.
- Always remove an exhausted battery from the vehicle. Battery leakage and corrosion can damage the vehicle.
- Do not store the battery on a surface (such as kitchen countertops) which could be damaged by the acid contained inside the battery. Take precautions to protect the surface on which you store the battery.
- Do not store the battery in temperatures above 75° F or below -10° F.
- Prevent the battery from moving freely inside the battery compartment. Always use the battery clamp to secure the battery in the battery compartment.
- Examine the battery, charger and its connector for excessive wear or damage each time you charge the battery. If damage is detected, do not use the charger or the battery until you have replaced the worn or damaged part.

### Disposal



- Your Power Wheels® battery is a sealed lead-acid battery. It must be recycled or disposed of in an environmentally sound manner.
- Do not dispose of a lead-acid battery in a fire. The battery may explode or leak.
- Do not dispose of a lead-acid battery in your regular, household trash. The incineration, landfilling or mixing of sealed lead-acid batteries with household trash is prohibited by law in most areas.
- Return exhausted batteries to a federal or state approved lead-acid battery recycler, such as a Power Wheels® authorized service center, or a local seller of automotive batteries. For the authorized service center location nearest to you, please call **1-800-348-0751**. Contact your local waste management officials for other information regarding the environmentally sound collection, recycling and disposal of lead-acid batteries. If you live in the State of Florida or the State of Minnesota, it is prohibited by law for anyone to throw away lead-acid batteries in the municipal waste stream.

## RIDING HAZARD



### WARNING

#### Prevent Injuries and Deaths

- Direct Adult Supervision Required
- Keep Children Within Safe Riding Areas

These areas must be:

- away from swimming pools and other bodies of water to prevent drownings
- generally level to prevent tipovers
- away from steps, driveways, cars, roads and alleys.

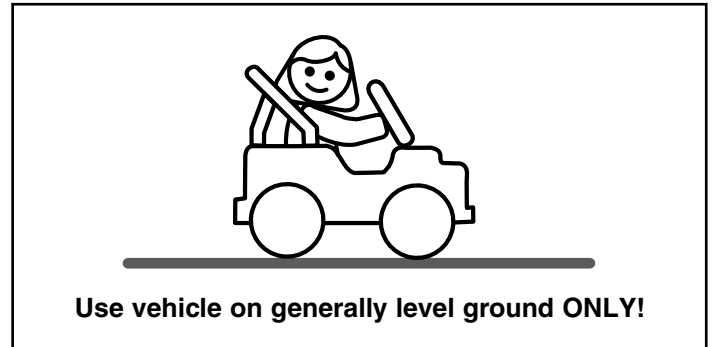

### Teach Safety Rules to Children

While children can quickly develop the skill necessary to drive this vehicle, it is important to remember that their judgment skills are still very immature. Unsupervised driving by children can lead to serious injury. Before children use this vehicle, an adult should carefully evaluate the driving area as well as the children's skill level and ability to drive this vehicle safely. Children are not always able to recognize or anticipate hazards, even when they have been taught about them. **There is no acceptable substitute for direct adult supervision.**

Teach appropriate safety rules to your child before allowing operation of this vehicle. These rules should also be reviewed with neighborhood children or other playmates who want to drive this vehicle.

### Riding Rules

**Make sure children know and follow these rules for safe driving:**

1. Always sit on the seat.
2. Always wear shoes.
3. Only 2 (two) riders at a time. Children that are not sitting on the seat or are standing on the vehicle could fall off, cause a tip-over or block the driver's view. Children could be seriously injured.
4. Do not allow any child to drive the vehicle in the street or near moving (motorized) vehicles.
5. Do not allow any child to drive near bodies of water (such as pools or creeks), obstructions (such as furniture, low tree limbs or play equipment), or drop-offs (such as stairs or decks).
6. Do not allow any child to drive the vehicle in the dark. A child could encounter unexpected obstacles and have an accident. Operate the vehicle only in the daytime or a well-lit area.

7. Do not allow your child to drive on sloped or inclined surfaces. **Restrict your child's driving to generally level ground ONLY!**
8. Do not allow your child to drive down or across a steep slope.
  - The vehicle may gain unsafe speed, even if the pedal is released to stop.
  - The vehicle may tilt and tip over.
  - The wheels could lose traction, causing the vehicle to slip.
9. Do not allow your child to drive up steep inclines. The motor may stop and the vehicle could roll backwards at an unsafe speed.
10. Never put anything near any moving parts. Rotating parts such as motors, gear boxes and wheels can snag fingers, hair, etc., causing serious injury. Do not allow operation of the vehicle when it is on its side or in an upside-down position.
11. Do not operate the vehicle near flammable vapors (gasoline, paint thinner, acetone, liquid wax, etc.). The vehicle's electrical switches, like most electrical switches, emit an internal spark when first turned on or turned off. The presence of flammable liquids or vapors could cause an explosion or a fire. Keep all flammable products in tightly sealed containers and away from the vehicle.
12. Do not allow a child to operate the vehicle without direct adult supervision. To prevent unsupervised use of the vehicle, disconnect the motor harness from the battery when the vehicle is not in use.

# K

## How to Operate Your Vehicle

**IMPORTANT!** Use this vehicle **ONLY** outdoors. Most interior flooring can be damaged by riding this vehicle indoors. Fisher-Price® will not be responsible for damage if this vehicle is used indoors.

### Beginner Use - Low Speed Drive

As assembled, your vehicle is ready to roll in low speed (2½ mph, maximum). It has been pre-set so it will only operate in low speed. After your child has mastered the basic skills of driving and understands the rules for safe driving, it's time to remove the high speed lock-out screw to allow the vehicle to operate in low or high speed.

**See the instructions on page 22 to remove the high speed lock-out screw.**

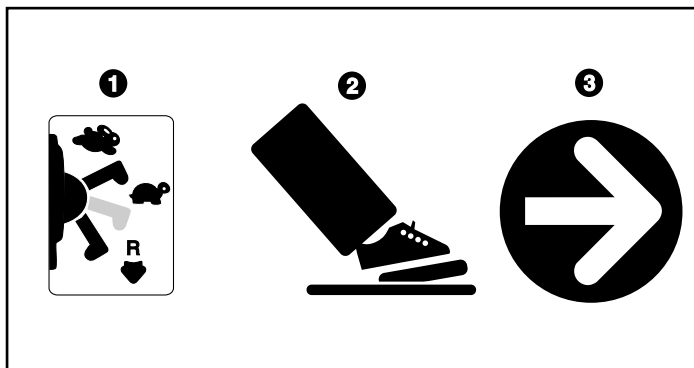

- Make sure the shifter is in the low speed  position ①.
- Press down on the foot pedal ②. The vehicle goes forward at a maximum of 2½ mph ③.
- Help your child practice steering to learn how far and how quickly to turn the steering wheel when driving forward in low speed.

### To Stop

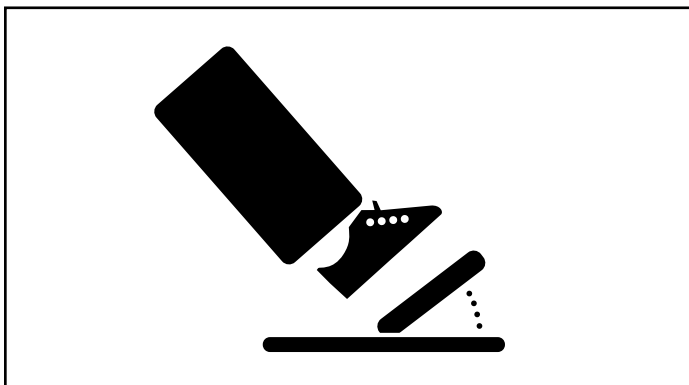

- Your vehicle has a patented electronic braking system that automatically stops the vehicle when your child's foot is lifted from the pedal.
- Make sure your child is comfortable with steering the vehicle and automatically knows how to stop.

### To Back Up

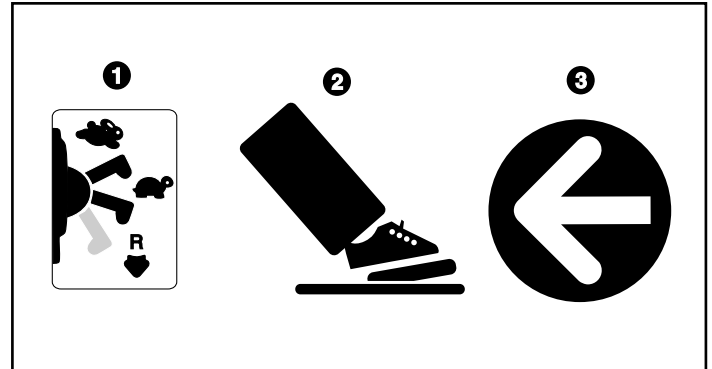

**IMPORTANT!** To avoid damaging the motors and gears, stop the vehicle before shifting from forward to reverse .

- Once your child is completely comfortable with operating the vehicle in the forward mode, introduce reverse .

#### To Back Up

- Make sure the shifter is in the reverse  position ①.
- Press down on the foot pedal ②. The vehicle will go in reverse at a maximum of 2½ mph ③. The vehicle is designed to operate in low speed only in reverse.
- Help your child practice steering to learn how far and how quickly to turn the steering wheel when driving in reverse.

## How to Operate Your Vehicle

### Advanced Use - High Speed Drive

#### Disconnecting the High Speed Lock-Out

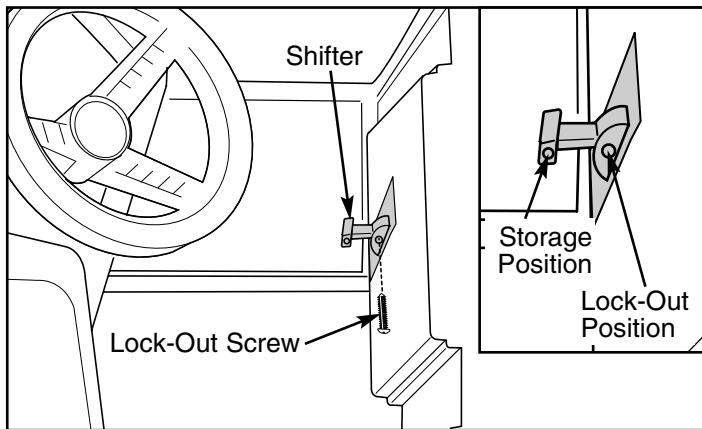

- Before you disconnect the high speed lock-out, make sure your child knows how to steer, how to start and stop the vehicle and knows the rules for safe driving. When the high speed lock-out is disconnected, the vehicle can be driven forward in low speed (2½ mph, maximum) or high speed (5 mph, maximum).
- Make sure the shifter is in the reverse  position.
- Loosen the screw in the shifter box using a Phillips screwdriver.
- Remove the screw.
- Insert the lock-out screw into the hole in the shifter handle to keep it for future use. It can be re-inserted into the shifter box to lock-out high speed.

### To Drive

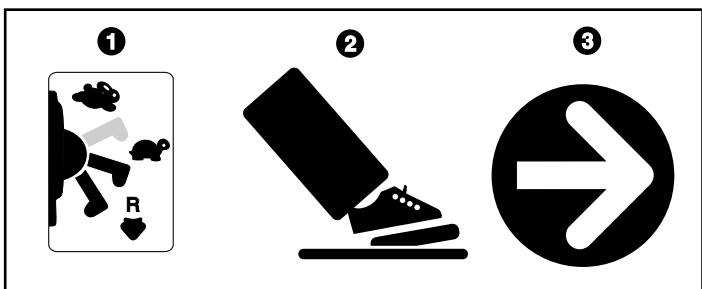

**IMPORTANT! To avoid damaging the motors and gears, stop the vehicle before shifting between low and high speed.**

- Make sure the shifter is in the high speed  position ①.
- Press down on the foot pedal ②. The vehicle moves forward at a maximum of 5 mph ③.
- Help your child practice steering to learn how far and how quickly to turn the steering wheel when driving forward in high speed.
- Make sure your child is comfortable with steering the vehicle and automatically knows how to stop.
- Stopping in high speed is the same as stopping in low speed. The vehicle automatically stops when your child's foot is lifted from the pedal.



## Caring For Your Vehicle

- Check all screws, cap nuts and protective coverings regularly and tighten as required. Check plastic parts on a regular basis for cracks or broken pieces.
- During snowy or rainy weather, the vehicle should be stored inside or under a protective cover. Remember to charge the battery at least once per month while your vehicle is not in regular use.
- Avoid operating the vehicle in wet or snowy conditions and do not spray the vehicle with a hose. Do not wash the vehicle with soap and water. Water or moisture in the motors or electrical switches can cause them to corrode and could cause switch or motor failure.
- Avoid operating the vehicle on sand, loose dirt or gravel. Sand, loose dirt or gravel in the motors or electrical switches can cause them to jam and could cause switch or motor failure.
- The vehicle can be wiped down with a soft, dry cloth. For a shiny finish, you can wipe plastic parts with a non-wax furniture polish applied to a soft-cloth. Do not use automotive wax. Do not use soap and water or spray the vehicle with a hose.
- To ensure that your vehicle stays in good operating order, we recommend that you periodically have your vehicle checked by a Power Wheels® authorized service center. For the location of the authorized service center nearest you, visit us on-line at [www.powerwheels.com](http://www.powerwheels.com).

# M

## Problems and Solutions Guide

**IMPORTANT!** If you experience a problem with your vehicle, first check the Problems and Solutions Guide below. If you still experience a problem, please contact Power Wheels® Consumer Relations, toll-free at **1-800-348-0751** between 8 AM and 6 PM (EST) Monday through Friday. Or, contact your local Power Wheels® authorized service center. For the location nearest you, please visit us on-line at [www.powerwheels.com](http://www.powerwheels.com).

Problem	Possible Cause	Solution
Vehicle does not run	Undercharged battery	<p>Charge the battery. A new battery should have been charged for at least 18 hours before using the vehicle for the first time. After first-time use, recharge the battery for at least 14 hours after each use. Never charge the battery longer than 30 hours.</p> <p>Check all connectors. Make sure the charger connector is plugged into the battery, and that the charger is plugged into the wall.</p> <p>Make sure power flow to the wall outlet is "ON".</p>
	Charger is not working	There is no sure way to tell if your charger is working unless you have a volt meter. If you suspect there is a problem with your charger, contact your local Power Wheels® authorized service center. They can test your charger for you.
	Tripped thermal fuse	Each Power Wheels® 12 volt battery has a built-in thermal fuse. A thermal fuse may "trip" and shut down operation of the vehicle if the vehicle is overloaded or the driving conditions too severe. The fuse will automatically reset itself after approximately 25 seconds, allowing the vehicle to resume normal operation. To avoid repeated automatic shutdowns, do not overload the vehicle by exceeding the 130 lb. (59 kg) maximum weight capacity or by towing anything behind the vehicle. Do not drive up hills or run into fixed objects, which can cause the wheels to stop spinning while power is still being supplied to the motors. If a thermal fuse continually trips, contact your local Power Wheels® authorized service center.
	Loose wire or loose connectors	Check all wires and connectors. Make sure the motor harness connector is plugged into the battery, and that there are no loose wires around the motors.
	Dead battery	If your battery is old or if you have not followed Battery Care instructions, your battery may be dead. If you are unsure whether or not the battery is dead, you can have it tested at your local Power Wheels® authorized service center.
	Electrical switch damage	The electrical switches can become corroded due to exposure to water or moisture, or can jam due to loose dirt, sand or gravel. Contact your local Power Wheels® authorized service center for diagnosis and repair.
	Motor damage	Contact your local Power Wheels® authorized service center for diagnosis and repair.

# Problems and Solutions Guide

Problem	Possible Cause	Solution
Vehicle was running but suddenly stopped	Loose wire or loose connectors	Check all wires and connectors. Make sure the motor harness connector is plugged into the battery, and that there are no loose wires around the motors.
	Tripped thermal fuse	Each Power Wheels® 12 volt battery has a built-in thermal fuse. A thermal fuse may “trip” and shut down operation of the vehicle if the vehicle is overloaded or the driving conditions too severe. The fuse will automatically reset itself after approximately 25 seconds, allowing the vehicle to resume normal operation. To avoid repeated automatic shutdowns, do not overload the vehicle by exceeding the 130 lb. (59 kg) maximum weight capacity or by towing anything behind the vehicle. Do not drive up hills or run into fixed objects, which can cause the wheels to stop spinning while power is still being supplied to the motors. If a thermal fuse continually trips, contact your local Power Wheels® authorized service center.
Short run time (less than 1 - 3 hours per charge)	Undercharged battery	Charge the battery. A new battery should have been charged for at least 18 hours before using the vehicle for the first time. After first-time use, recharge the battery for at least 14 hours after each use. Never charge the battery longer than 30 hours.
		Check all wires and connectors. Make sure the charger connector is plugged into the battery, and that the charger is plugged into the wall.
		Make sure power flow to the wall outlet is “ON”.
	Overcharged battery	Do not charge the battery longer than 30 hours. If you suspect that your battery is damaged as a result of overcharging, contact your local Power Wheels® authorized service center. They can test your battery for you.
	Battery is old and will not accept full charge	Even with proper care, a rechargeable battery does not last forever. Average battery life is 1 to 3 years depending on vehicle use and use conditions. Replace the battery with a new Power Wheels® 12 volt rechargeable battery. Do not substitute parts.
	Tripped thermal fuse	Each Power Wheels® 12 volt battery has a built-in thermal fuse. A thermal fuse may “trip” and shut down operation of the vehicle if the vehicle is overloaded or the driving conditions too severe. The fuse will automatically reset itself after approximately 25 seconds, allowing the vehicle to resume normal operation. To avoid repeated automatic shutdowns, do not overload the vehicle by exceeding the 130 lb. (59 kg) maximum weight capacity or by towing anything behind the vehicle. Do not drive up hills or run into fixed objects, which can cause the wheels to stop spinning while power is still being supplied to the motors. If a thermal fuse continually trips, contact your local Power Wheels® authorized service center.

# Problems and Solutions Guide

Problem	Possible Cause	Solution
Vehicle runs sluggishly	Undercharged battery	Charge the battery. A new battery should have been charged for at least 18 hours before using the vehicle for the first time. After first-time use, recharge the battery for at least 14 hours after each use. Never charge the battery longer than 30 hours.
		Check all connectors. Make sure the charger connector is plugged into the battery, and that the charger is plugged into the wall.
		Make sure power flow to the wall outlet is "ON".
	Battery needs charging	Be sure to charge the battery after each use.
	Battery is old and will not accept full charge	Even with proper care, a rechargeable battery does not last forever. Average battery life is 1 to 3 years depending on the vehicle use and use conditions. Replace the battery with a new Power Wheels® 12 volt rechargeable battery. Do not substitute parts.
	Vehicle is overloaded	Make sure you do not overload the vehicle by allowing more than 2 riders at one time, by exceeding the 130 lb. maximum weight capacity, or by towing objects behind the vehicle.
	Driving conditions are too stressful	Use only on generally level ground.
Vehicle runs in low speed, but does not run in high speed  Note: The vehicle operates in low speed only when in reverse.	High speed lock-out not disconnected	The vehicle was pre-set to run only in low speed. To allow the vehicle to run in low and high speed, you must disconnect the High Speed Lock-Out. <b>Follow the instructions on page 22 to remove the High Speed Lock-Out screw.</b>
When the foot pedal is pressed only one rear wheel spins	Operation of vehicle in low speed	It is possible that only one rear wheel may spin when both rear wheels are raised off the ground and the vehicle is in low speed. This does not necessarily indicate a problem. Check for proper operation of the drive system by raising the rear wheels off the ground and pressing the foot pedal. If only one rear wheel spins, carefully press your hand on the spinning wheel to slow it down. The other rear wheel should begin to spin. If the other rear wheel does not begin to spin, there may be a problem with the vehicle. Contact your local Power Wheels® authorized service center for diagnosis and repair.
Sometimes the vehicle doesn't run, but other times it does	Loose wire or connector	Check all wires around the motors and all connectors to make sure they are tight.
	Motor or electrical switch damage	Contact your local Power Wheels® authorized service center for diagnosis and repair.

## Problems and Solutions Guide

Problem	Possible Cause	Solution
When the foot pedal is pressed, the vehicle won't run without a push	Loose wire or connector	Check all wires around the motors and all connectors to make sure they are tight.
	"Dead Spot" on motor	Contact your local Power Wheels® authorized service center for diagnosis and repair.
Loud clacking or grinding noise from a motor-gearbox	Broken gears	Contact your local Power Wheels® authorized service center for diagnosis and repair.
Charger gets warm during use	It is normal for some chargers to get warm during use and is not reason for concern.	No action required.
		If your charger does not get warm during use, it does not mean that it is not working properly.
Battery makes a sizzling or gurgling noise when charging	It is normal for some batteries to make noise and swell slightly while charging and is not reason for concern.	No action required.
		If your battery does not make noise or swell slightly during charging, it does not mean that it is not accepting the charge.

If, after reviewing the Problems and Solutions Guide, the vehicle still fails to operate, please contact your nearest authorized service center (see page 28) or contact Power Wheels® Consumer Relations toll-free at **1-800-348-0751**.

**Hint:** For faster service when calling Consumer Relations, completely charge the battery before calling and have the following available by the phone:

- vehicle,
- vehicle model number (see label in battery compartment),
- vehicle production run number (see label in battery compartment).

**N**

## Bumper-to-Bumper\* Limited Warranty

**\*One year limited warranty from the date of purchase on the Power Wheels® vehicle.  
Six month limited warranty on the 12 volt battery.**

For the original purchaser, this one year limited warranty covers the Power Wheels® ride-on vehicle (purchased from Power Wheels®) against defects in materials and workmanship. The six month limited warranty applies only to the 12 volt battery included by Power Wheels® with the original purchase of the vehicle.

This warranty covers normal use and does not cover the Power Wheels® vehicle or battery if damaged by unreasonable use, neglect, accident, abuse, misuse, improper service or other causes not arising out of defects in materials or workmanship. Evidence of any attempt at consumer repair will void this warranty. THIS WARRANTY DOES NOT COVER, AND IS INTENDED TO EXCLUDE, ANY LIABILITY ON THE PART OF POWER WHEELS®, WHETHER UNDER THIS WARRANTY OR IMPLIED BY LAW FOR ANY INDIRECT OR CONSEQUENTIAL DAMAGES FOR BREACH OF WARRANTY. SOME STATES DO NOT ALLOW THE EXCLUSION OR LIMITATION SO THIS LIMITATION MAY NOT APPLY TO YOU. Should you need service or assistance with your vehicle during the warranty period, **do not return the vehicle to the store.** Power Wheels® has provided a nationwide network of authorized service centers. For the location of the authorized service center nearest you, please visit us on-line at [www.powerwheels.com](http://www.powerwheels.com) or call **1-800-348-0751**. Power Wheels® is continually expanding our Authorized Service Center Network. If there is not an authorized service center in your area, please call Consumer Relations for information, **1-800-348-0751**.

THIS WARRANTY GIVES YOU SPECIFIC LEGAL RIGHTS, AND YOU MAY ALSO HAVE OTHER RIGHTS WHICH MAY VARY FROM STATE TO STATE.

**PLEASE SAVE YOUR ORIGINAL SALES RECEIPT.**

# IMPORTANT!

**DO NOT use this vehicle for the first time until you have charged the battery for 18 hours.**

Remember to...

- ✓ Charge the battery immediately after each use.
- ✓ Charge the battery once a month during storage, even if the vehicle has not been used.

Failure to follow these instructions will permanently damage your battery and void your warranty. Please refer to the Battery Care Section in this manual for more information. For high speed operation, please refer to the How to Operate Your Vehicle Section in this manual for more information.

## DO NOT Return your Vehicle to the Store!



If you are missing parts or need assistance, please call us toll-free:

**Power Wheels® Consumer Relations**

**1-800-348-0751**

**8 AM - 6 PM EST, Monday through Friday.**

Or contact your local, **independently owned and operated** Power Wheels® Authorized Service Center.

For the location nearest you, visit us on-line at [www.powerwheels.com](http://www.powerwheels.com).

Fisher-Price, Power Wheels by Fisher-Price, Power Lock and Power Stick are U.S. trademarks of Mattel, Inc. Fisher-Price, Inc., a subsidiary of Mattel, Inc., East Aurora, New York 14052 U.S.A.  
©2003 Mattel, Inc. All Rights Reserved.