

This Owner's Manual is provided and hosted by [Appliance Factory Parts](http://ApplianceFactoryParts.com).

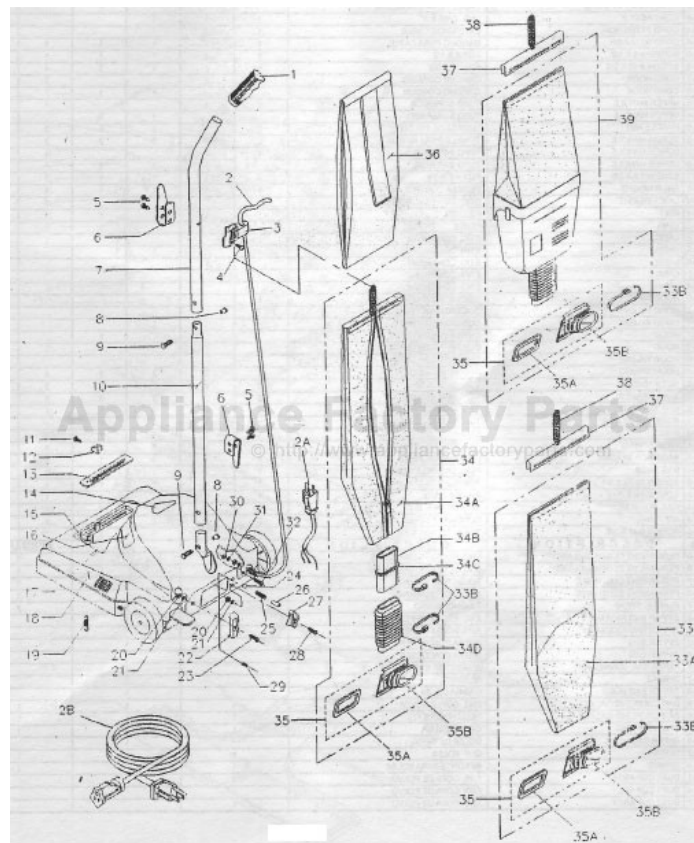

Koblenz U-110 Owner's Manual

[Shop genuine replacement parts for Koblenz U-110](#)



[Find Your Koblenz Vacuum Cleaner Parts - Select From 30 Models](#)

----- Manual continues below -----

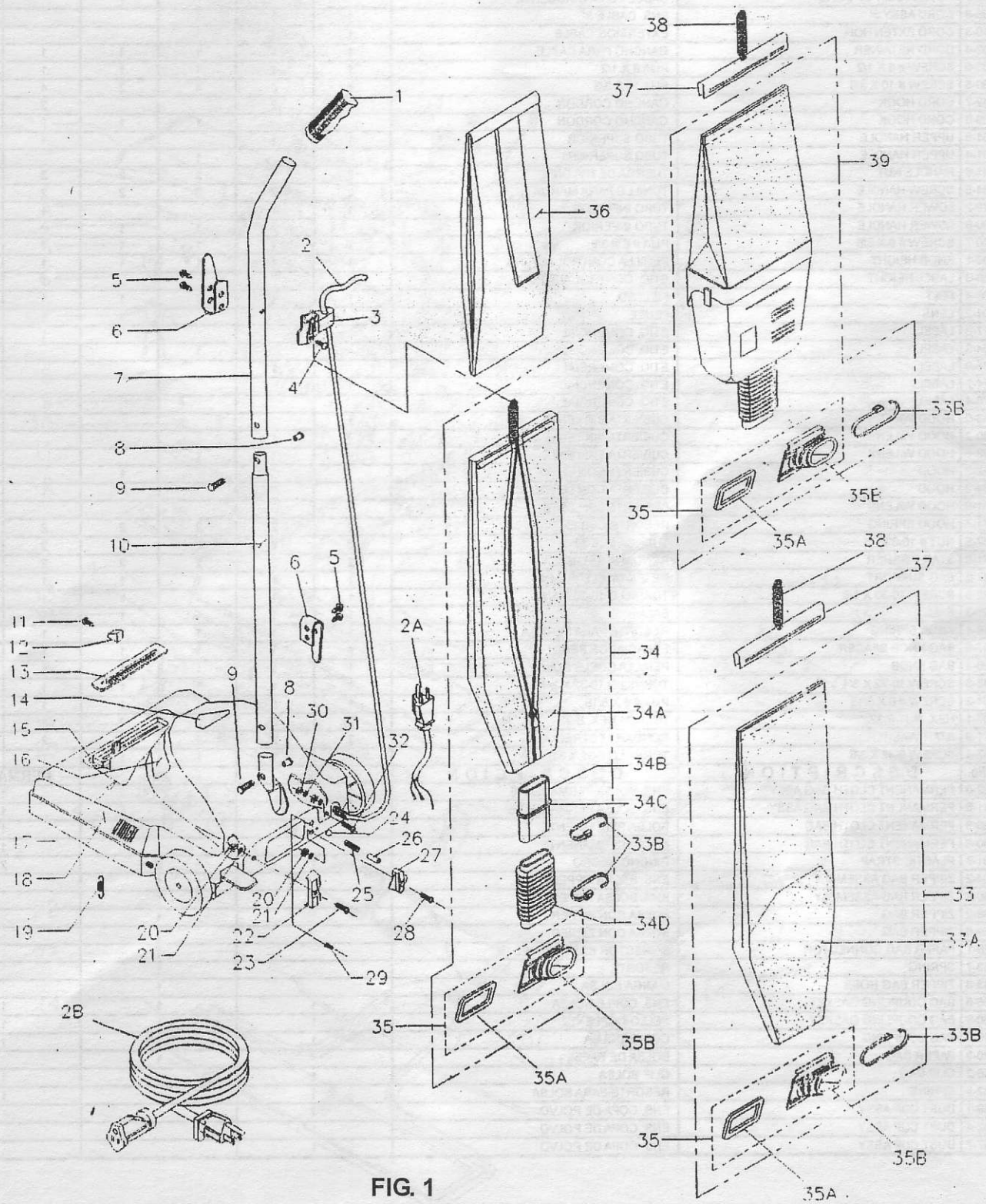
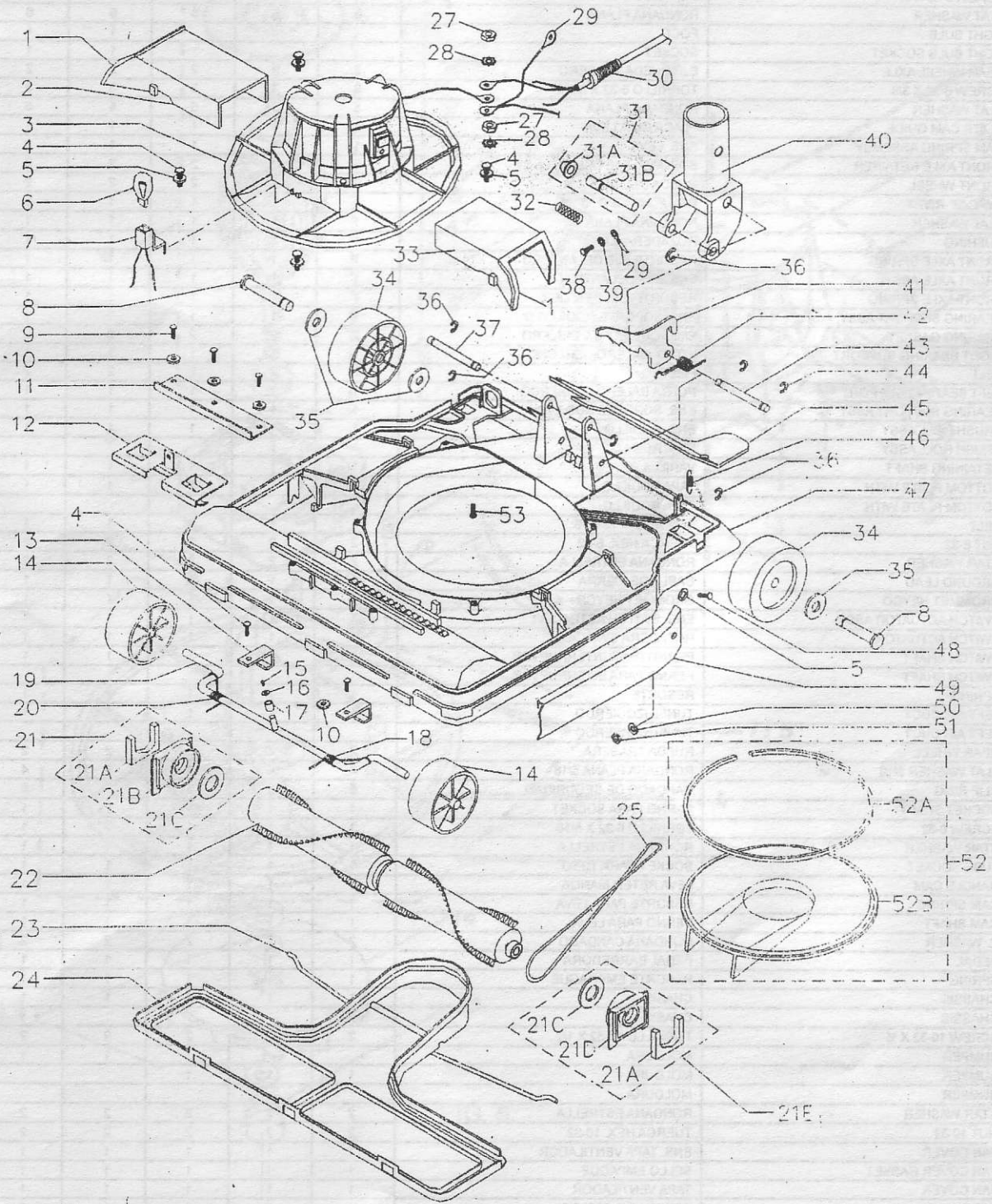

FIG. 1

POS	PART No.	DESCRIPTION	DESCRIPCION	U-510	U-310	U-110	U-180	U-240	U-610
1	13-0947-5	HANDLE GRIP	MANGO ASIDERA	1	1	1	1	1	1
2	28-0534-9	POWER SUPPLY CORD	CABLE TOMA CORRIENTE					1	
2	28-1152-9	POWER SUPPLY CORD	CABLE TOMA CORRIENTE				1		
2-A	28-1256-8	CORD ASSY 3"	ENS. CABLE 3"	1	1	1			1
2-B	09-1310-3	CORD EXTENTION	EXTENSION CABLE	1	1	1			1
3	13-1462-4	CORD RETAINER	GANCHO PARA CABLE	1	1	1	1	1	1
4	01-0283-0	SCREW # 8 X 1/2	PIJA 8 X 1/2	1	1	1	1	1	1
5	01-0290-5	SCREW # 10 X 3/8	PIJA 10 X 3/8	4	4	4	2	4	4
6	05-2142-7	CORD HOOK	GANCHO CORDON	2	2			2	2
6	05-4089-8	CORD HOOK	GANCHO CORDON			1	1		
7	05-4051-8	UPPER HANDLE	TUBO SUPERIOR	1	1			1	1
7	05-4091-4	UPPER HANDLE	TUBO SUPERIOR			1	1		
8	02-0141-8	HANDLE NUT	TUERCA DE NYLON	2	2	2	2	2	2
9	01-2034-5	SCREW HANDLE	TONILLO PARA MANIJA	2	2	2	2	2	2
10	05-4049-2	LOWER HANDLE	TUBO INFERIOR	1	1			1	1
10	05-4090-6	LOWER HANDLE	TUBO INFERIOR			1	1		
11	01-0270-7	SCREW # 6 X 3/8	PIJA # 6 X 3/8	1	1	1	1	1	1
12	13-1100-1	KNOB HEIGHT	PERILLA CONTROL ALTURA	1	1	1	1	1	1
13	17-2486-3	LABEL HEIGHT	ETIQ. CONTROL ALTURA					1	
15	37-0136-4	FELT	FIELTRO	1	1	1	1	1	1
16	13-1401-2	LENS	LENTE				1	1	
17	17-2877-3	LABEL	ETIQ. COMERCIAL					1	
17	17-4334-3	LABEL	ETIQ. COMERCIAL			1			
17	17-4335-0	LABEL	ETIQ. COMERCIAL		1				
17	17-4474-7	LABEL	ETIQ. COMERCIAL	1					
17	17-4475-4	LABEL	ETIQ. COMERCIAL						1
18	05-3343-0	HOOD W/LENS	CUBIERTA SIN LENTE	1					
18	05-4389-2	HOOD W/LENS	CUBIERTA SIN LENTE		1				
18	05-4392-6	HOOD W/LENS	CUBIERTA SIN LENTE			1			
18	05-4092-2	HOOD	CUBIERTA CON LENTE				1		
18	05-3064-2	HOOD	CUBIERTA CON LENTE					1	
18	05-4391-8	HOOD W/LENS	CUBIERTA SIN LENTE						1
19	24-0271-7	HOOD SPRING	RESORTE CUBIERTA	2	2	2	2	2	2
20	02-0037-8	NUT # 10-32	TUERCA # 10-32	2	2	2	2	2	2
21	04-0271-9	STAR WASHER	RONDANA ESTRELLA	2	2	2	2	2	2
22	13-2127-2	BAG SUPPORT	RETEN COPLE BOLSA	1	1	1	1	1	1
23	01-0742-5	SCREW 10-30 X 5/8	TORNILLO 10-30 X 5/8	1	1	1	1	1	1
24	26-0001-3	BALL	BALA	1	1	1	1	1	1
25	24-0014-1	KNOB SPRING	RESORTE PARA PERILLA	1	1	1	1	1	1
26	05-0997-6	BAG KNOB SPACER	ESPACIADOR PERILLA	1	1	1	1	1	1
27	13-2126-4	BAG KNOB	PERILLA COPLE BOLSA	1	1	1	1	1	1
28	01-0743-3	SCREW 10-32 X 3/4	TORNILLO 10-32 X 3/4	1	1	1	1	1	1
29	01-0154-3	SCREW # 6 X 5/16	PIJA # 6 X 5/16	1	1	1	1	1	1
30	02-0007-1	HEX. NUT 8-32	TUERCA HEX. 8-32	2	2	2	2	2	2
31	04-0271-9	STAR WASHER	RONDANA ESTRELLA	2	2	2	2	2	2
32	01-1247-4	SCREW 8-32 X 3/8	TORNILLO 8-32 X 3/8	1	1	1	1	1	1
POS	PART No.	DESCRIPTION	DESCRIPCION	DC	ZIP	PERMANENT			
33	46-2432-6	PERMANENT CLOTH BAG ASSY	ENS. BOLSA PERMANENTE					1	
33	46-2941-6	PERMANENT CLOTH BAG ASSY	ENS. BOLSA PERMANENTE					1	
33-A	45-0490-8	PERMANENT CLOTH BAG	BOLSA PERMANENTE					1	
33-A	45-0560-8	PERMANENT CLOTH BAG	BOLSA PERMANENTE					1	
33-B	13-1601-7	PLASTIC STRAP	CINCHO NEGRO	1				2	
34	46-2434-2	ZIPPER BAG ASSEMBLY	ENS. BOLSA ZIPPER			1			
34	46-2940-8	ZIPPER BAG ASSEMBLY	ENS. BOLSA ZIPPER			1			
34-A	45-0488-2	ZIPPER BAG	BOLSA CON ZIPPER			1			
34-A	45-0559-0	ZIPPER BAG	BOLSA CON ZIPPER			1			
34-B	13-1128-1	PAPER BAG CONNECTOR	CONECTOR BOLSA PAPEL			1			
34-C	24-0233-7	SPRING	RESORTE			1			
34-D	12-0548-3	ZIPPER BAG HOSE	MANGA BOLSA			1			
35	46-2105-8	BAG COUPLING GASKET	ENS. COPLE BOLSA	1		1		1	
35-A	12-0550-9	BAG COUPLING GASKET	SELLO COPLE	1		1		1	
35-B	13-2196-7	BAG COUPLING	COPLE BOLSA	1		1		1	
36	45-0220-9	PAPER BAG	BOLSA DE PAPEL			1			
37	05-3356-2	CLIP BAG	CLIP BOLSA	1					1
38	24-0232-9	SPRING	RESORTE PARA BOLSA	1					1
39	46-2439-1	DUST CUP ASSY	ENS. COPA DE POLVO	1					
39	46-2942-4	DUST CUP ASSY	ENS. COPA DE POLVO	1					
39	46-2747-7	DUST CUP ASSY	ENS. COPA DE POLVO	1					



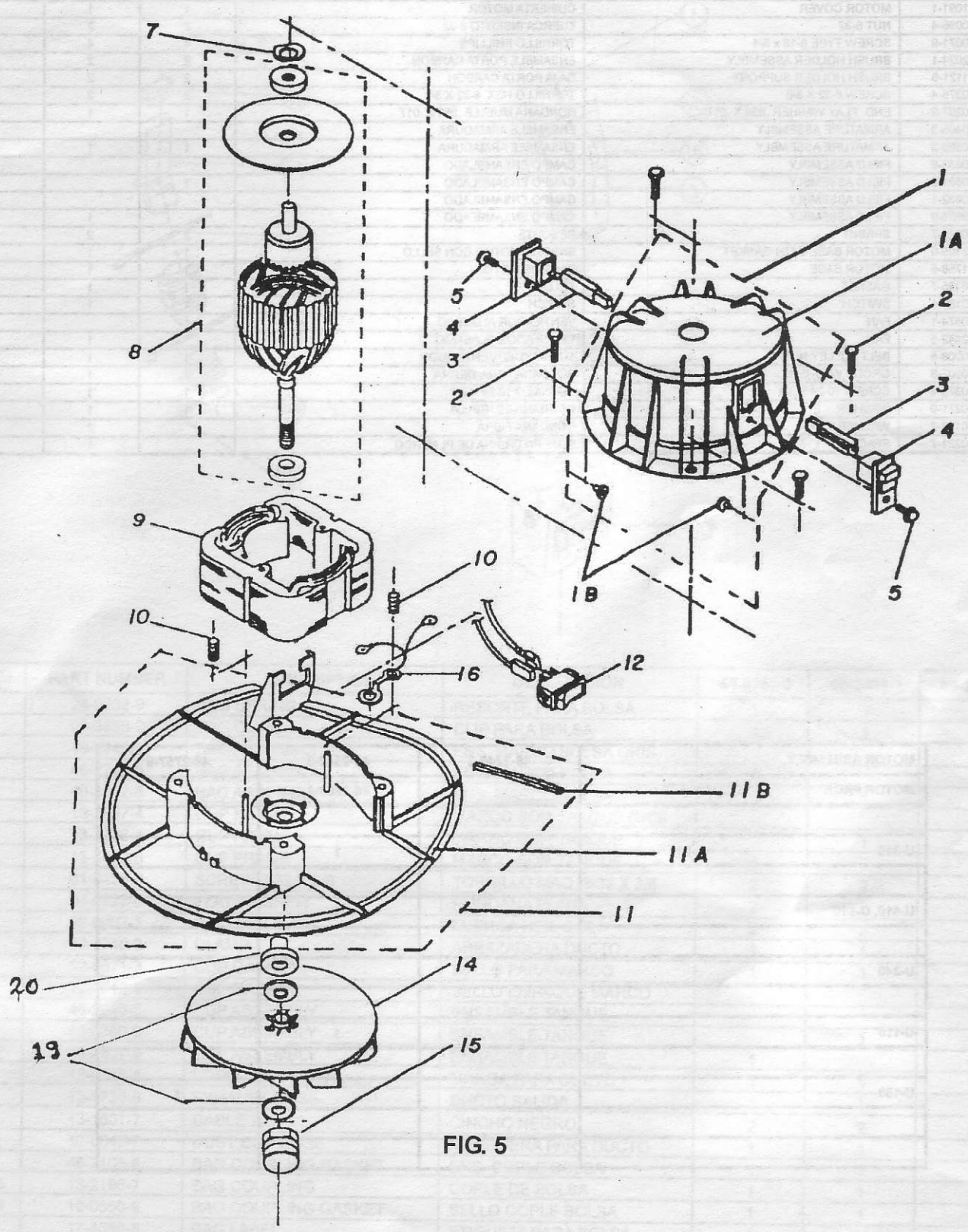
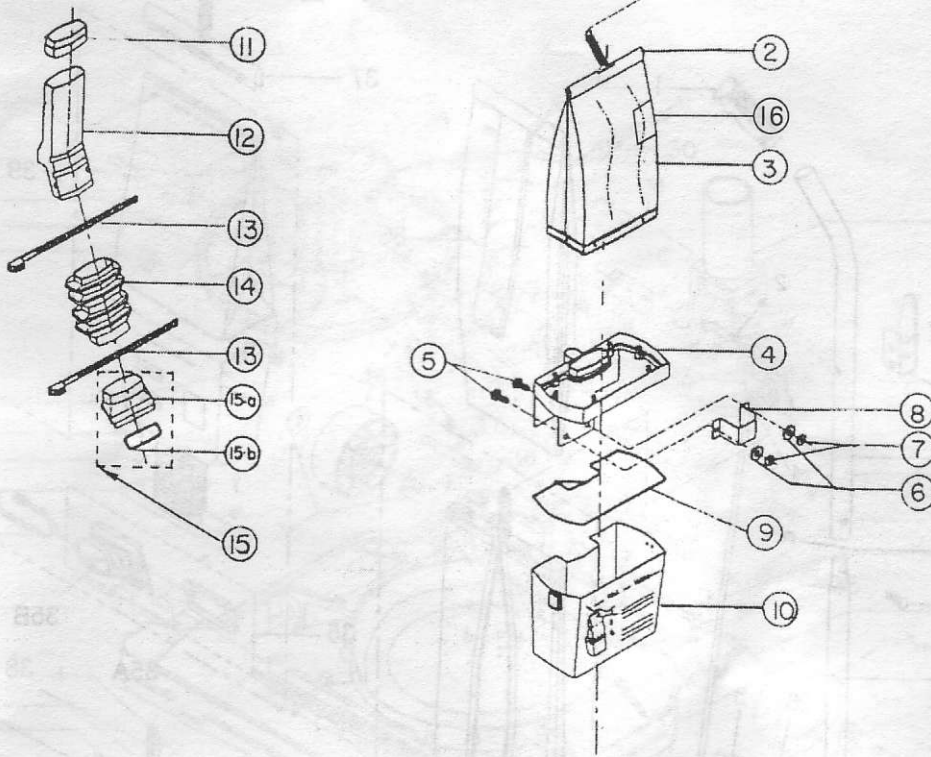

FIG. 5

ITEM	PART No.	DESCRIPCION	DESCRIPTION	46-2240-3	46-2542-2	46-2757-6
1	46-2108-2	MOTOR COVER ASSEMBLY	ENSAMBLE CUBIERTA MOTOR	1	1	1
1-A	13-1091-1	MOTOR COVER	CUBIERTA MOTOR	1	1	1
1-B	02-0096-4	NUT 8-32	TUERCA INSERTO 8-32	2	2	2
2	01-0071-9	SCREW TYPE 8-18 x 3/4	TORNILLO PHILLIPS	4	4	4
3	46-2024-1	BRUSH HOLDER ASSEMBLY	ENSAMBLE PORTA CARBON	2	2	2
4	13-1121-6	BRUSH HOLDER SUPPORT	CAJA PORTA CARBON	2	2	2
5	01-0375-4	SCREW 8-32 X 3/8	TORNILLO HEX. 8-32 X 3/8	2	2	2
7	04-0397-2	END. PLAY WASHER .850 X .017	RONDANA MUELLE .850 X .017	1	1	1
8	28-0405-2	ARMATURE ASSEMBLY	ENSAMBLE ARMADURA			
8	28-0580-2	ARMATURE ASSEMBLY	ENSAMBLE ARMADURA	1	1	1
9	28-0633-9	FIELD ASSEMBLY	CAMPO ENSAMBLADO			
9	28-0581-0	FIELD ASSEMBLY	CAMPO ENSAMBLADO	1		
9	28-0632-1	FIELD ASSEMBLY	CAMPO ENSAMBLADO			1
9	28-0628-9	FIELD ASSEMBLY	CAMPO ENSAMBLADO		1	
10	24-0228-7	SPRING	RESORTE	2	2	2
11	46-2109-0	MOTOR BASE WITH GASKET	BASE DE MOTOR CON SELLO	1	1	1
11-A	13-1758-5	MOTOR BASE	BASE DE MOTOR	1	1	1
11-B	12-0495-7	GASKET	SELLO	1	1	1
12	11-0159-1	SWITCH	SWITCH	1	1	1
14	06-0574-1	FAN	VENTILADOR ALUMINIO	1		
14	KO-4505244	FAN	VENTILADOR PLASTICO		1	1
15	02-0208-5	BELT PULLEY NUT	TUERCA DEL VENTILADOR	1	1	1
16	30-0207-8	GROUP WASHER	RONDANA PARA TIERRA	1	1	1
17	01-0375-4	SCREW 10-24 X 3/8	TORNILLO 10.24 X 3/8	1	1	1
18	04-0271-9	WASHER	RONDANA ESTRELLA	1	1	1
19	04-0123-2	WASHER	RONDANA FIBRA		2	2
20	26-0221-7	SPACER	BUJE P/TURBINA DE PLASTICO		1	1



ITEM	PART NUMBER	DESCRIPTION	DESCRIPCION	46-2747-7	46-2439-1	46-2942-4
1	24-0232-9	BAG SPRING	RESORTE PARA BOLSA	1	1	1
2	05-3356-2	BAG CLIP	CLIP PARA BOLSA	1	1	1
3	46-2943-2	BAG ASSEMBLY	ENS. MARCO BOLSA GRIS			1
3	46-2748-5	BAG ASSEMBLY	ENS. MARCO BOLSA	1		
3	46-2442-5	BAG ASSEMBLY	ENS. MARCO BOLSA		1	
4	13-2697-4	CUP FRAME	MARCO SOP. TANQUE GRIS			1
4	13-1736-1	CUP FRAME	MARCO SOP. TANQUE		1	
4	13-2470-6	CUP FRAME	MARCO SOP. TANQUE	1		
5	01-0438-0	SCREW 8-32 X 3/8	TORNILLO MAQ. 8-32 X 3/8	2	2	2
6	04-0022-6	FLAT WASHER	RONDANA PLANA	2	2	2
7	02-0007-1	HEX. NUT 8-32	TUERCA HEX. 8-32	2	2	2
8	13-1740-3	CLAMP	ABRAZADERA DUCTO	1	1	1
9	12-0671-3	CUP GASKET	SELLO PARA MARCO	1	1	
9	12-0712-5	CUP GASKET	SELLO EMPAQUE MARCO			1
10	46-2946-5	CUP ASSEMBLY	ENSAMBLE TANQUE			1
10	46-2360-9	CUP ASSEMBLY	ENSAMBLE TANQUE		1	
10	46-2807-9	CUP ASSEMBLY	ENSAMBLE TANQUE	1		
11	12-0646-5	UPPER HOSE SEAL	MANGA PARA DUCTO	1	1	1
12	13-1739-5	EXHAUST HOSE	DUCTO SALIDA	1	1	1
13	13-1601-7	CABLE TIE	CINCHO NEGRO	2	2	2
14	12-0645-7	DUST CUP HOSE	MANGUERA PARA DUCTO	1	1	1
15	46-2105-8	BAG COUPLING GASKET	ENS. COPLER BOLSA	1	1	1
15-A	13-2196-7	BAG COUPLING	COPLER DE BOLSA	1	1	1
15-B	12-0550-9	BAG COUPLING GASKET	SELLO COPLER BOLSA	1	1	1
16	17-4050-5	BAG LABEL	ETIQUETA PARA BOLSA	1		