

EXPLODED VIEW (NOZZLE HOUSING)... **A** BLOCK

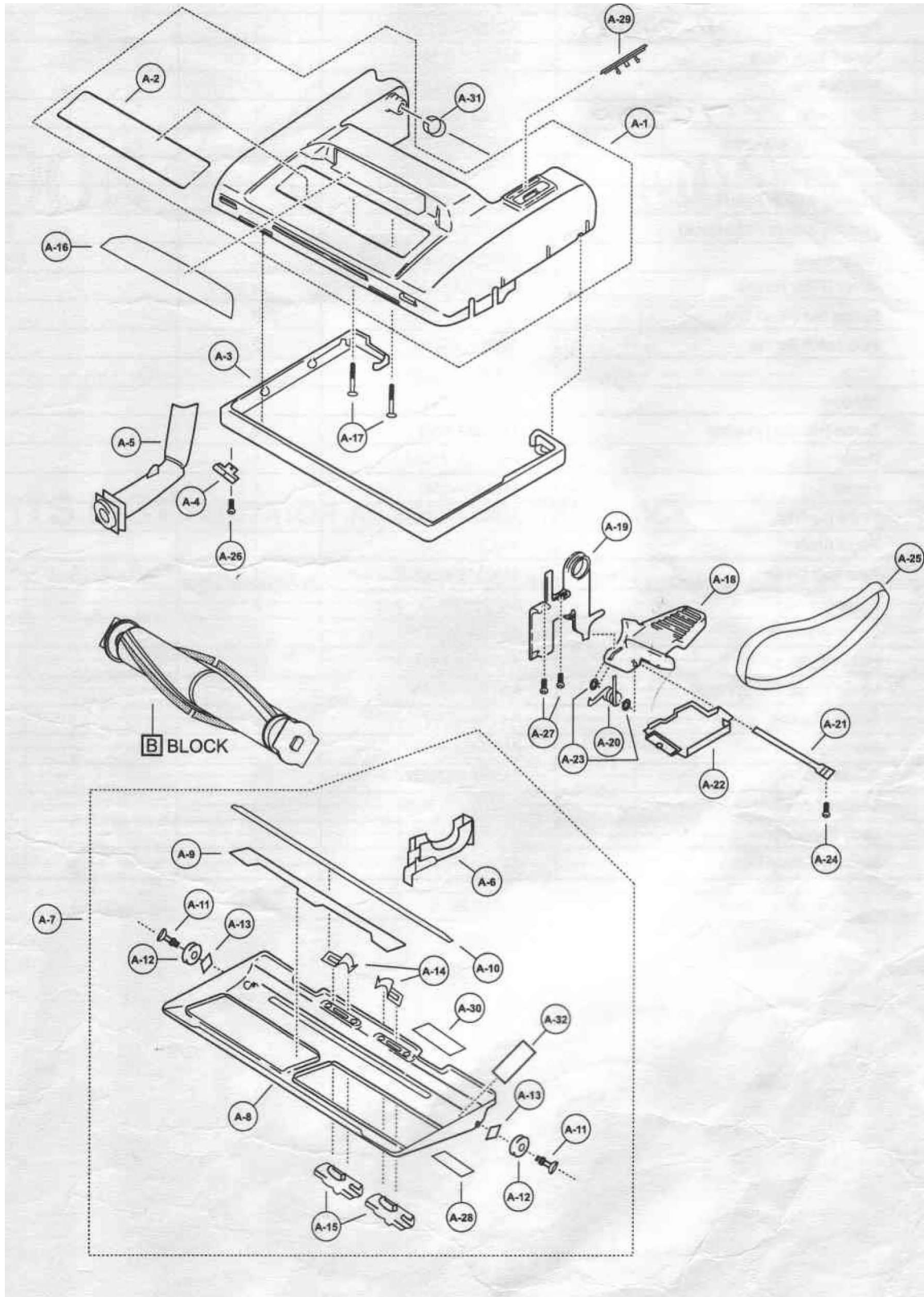

PARTS LIST (NOZZLE HOUSING)... **A** BLOCK

Ref. No.	Part Name & Description	Part No.	Quantity	Remarks
A - 1	Nozzle Housing	AC01AARGZV07	1	
A - 2	Top Mark	AC02TARGZ00	1	
A - 3	Furniture Guard	AC10AV3ZV07	1	
A - 4	Hose Fitting Plate	AMC27S-V30	1	
A - 5	Nozzle Pipe	AMC70S-V30W	1	
A - 6	Belt Cover	AC43STDZ00	1	
A - 7	Lower Plate Assembly	AC91AARGZ00	1	
A - 8	Lower Plate	AC27AARGZ00	1	
A - 9	Packing (Lower Plate Front)	AMC19A-V30	1	
A - 10	Packing (Lower Plate Back)	AMC74A-V30	1	
A - 11	Roller Shaft	AMC50R-V30	2	
A - 12	Roller (Floor Nozzle)	AC90RJMZ00	2	
A - 13	Spring Nut (Push On)	AMC-XNK4FY	2	
A - 14	Stop Latch Spring	AC70NYUZ00	2	
A - 15	Latch	AMC68N-V30K	2	
A - 16	Window	AC21H1LZVU7	1	
A - 17	Screw (Nozzle Housing)	AMC68A-V30	2	
A - 18	Pedal	AMC47A-V30U	1	
A - 19	Frame	AMC43A-V30	1	
A - 20	Pedal (Spring)	AMC58A-V30	1	
A - 21	Pedal Shaft	AMC51A-V30	1	
A - 22	Rear Belt Cover	AMC11S-V30W	1	<i>i</i>
A - 23	E-Clip	AMC-XUC4FY		
A - 24	Screw (Pedal Shaft)	AXTN4+20BFY	1	
A - 25	Flat Belt	AMC28S-AV0	1	
A - 26	Screw (Hose Fitting Plate)	AXTN4+16BFY	1	
A - 27	Screw (Frame)	AXTN4+20BFY		
A - 28	Warning Label	AMC08Z-V30	1	
A - 29	Cover Plate	AC24ATDZV07	1	
A - 30	Caution Label	AC07ZADFZ00	1	
A - 31	Body Supporter	AMC02C-1L0	1	
A - 32	Packing (Lower Plate)	AC39AARGZ00	1	

EXPLODED VIEW (AGITATOR ASSEMBLY)... B BLOCK

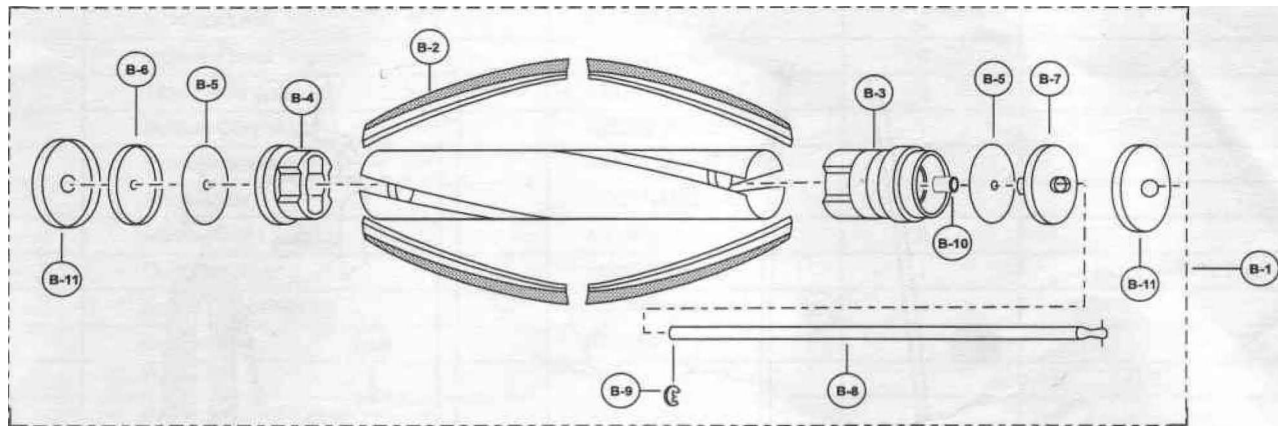

PARTS LIST (AGITATOR ASSEMBLY)... B BLOCK

Ref. No.	Part Name & Description	Part No.	Quantity	Remarks
B - 1	Agitator Assembly	AC92SARGZ00 Zool	U> 1	j S
B - 2	Brush (4 Pes.) p. 3.030	AC85RARGZ00 V	1	/
B - 3	Agitator Pulley LOC*	AC29SV01U00 aFfiAfi. tf		
B - 4	Agitator Holder ^ O ^ 1	AC41SJMZ00	1	
B - 5	Filter	AC44KJMZ00		
B - 6	End Cap Left	AC97DJMZ00	1	
B - 7	End Cap Right	AC96DJMZ00 x r t > /	1	
B - 8	Agitator Shaft	mssstmm	jQfiad)	
B - 9	E-Clip	AMC-XUC4FY	1	
B - 10	Spacer	AC74SARGZ00	1	
B - 11	End Cap Cover	AC96DARFZ00	2	l o 3

EXPLODED VIEW (DUST CONTAINER AND HANDLE)... [C] BLOCK

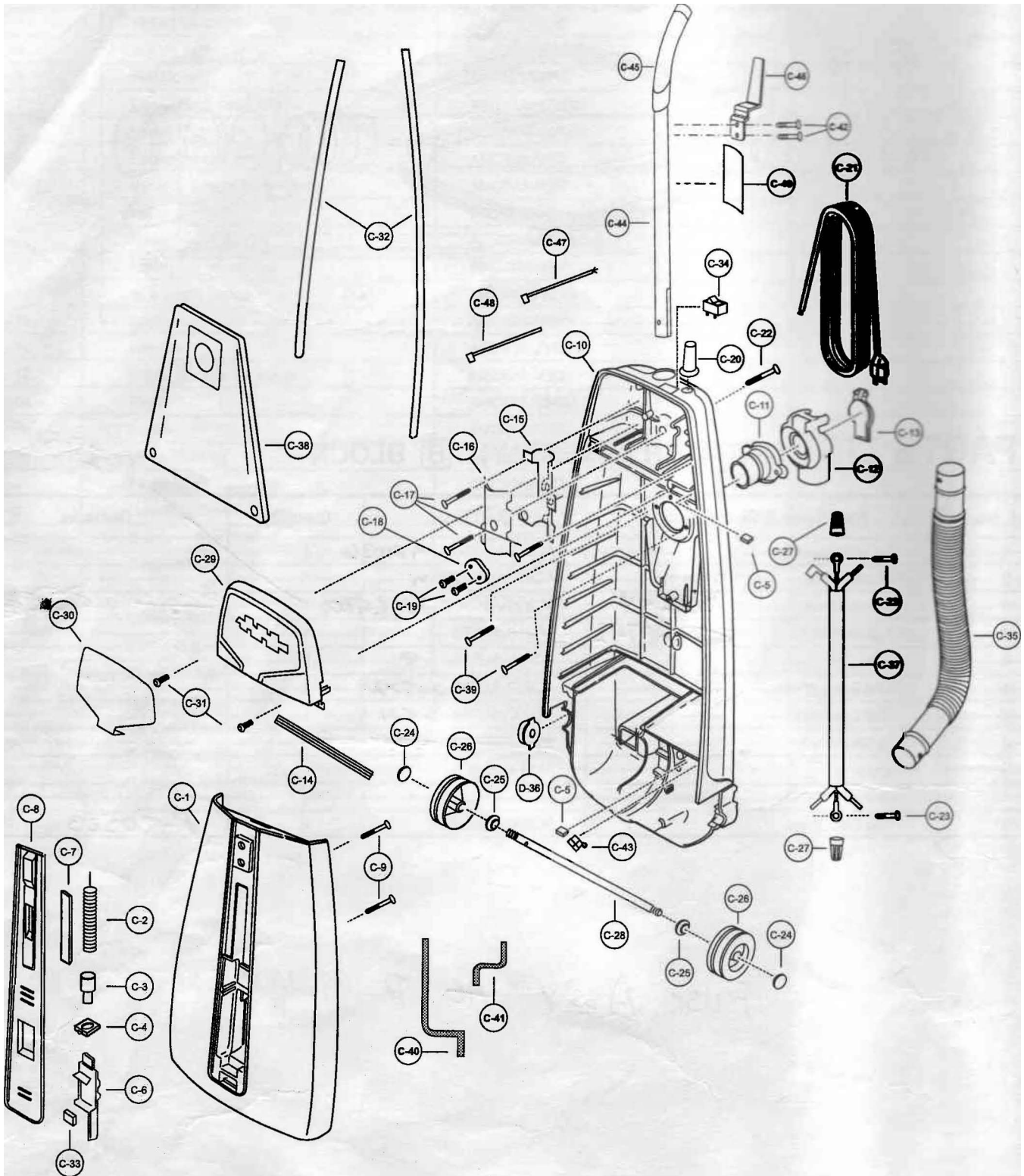

PARTS LIST (DUST CONTAINER AND HANDLE)... **C** BLOCK

Ref. No.	Part Name & Description	Part No.	Quantity	Remarks
C - 1	Dust Cover	AC60KARGZVU7	1	
C - 2	Indicator Spring	AMC04M-1L0	1	
C - 3	Indicator Lead	AMC97M-V30	1	
C - 4	Indicator Lead Supporter	AMC20M-V30	4	
C - 5	Tight Packing	AMC81A-1L000	2	
C - 6	Suction Control Lever	AC06MV31V07	1	
C - 7	Indicator Window	AMC08M-V30	1	
C - 8	Front Cover	AC01HARGZVU7	2	
C - 9	Screw (Dust Cover)	AXTN4+16BFY	2	
C - 10	Dust Container	AC40KTDZVU7	1	Includes C-32 Packing
C - 11	Suction Inlet Packing	AMC64H-9G00U	1	
C - 12	Suction Inlet	AC60HF74V07	1	
C - 13	Cover	AC02HF73V07	1	
C - 14	Packing (Switch Cover)	AC73KV3ZV06	1	
C - 15	Handle Supporter	AMC53B-1LZ00	1	
C - 16	Handle Fitting	AMC69B-V3Z00	1	
C - 17	Screw (Handle Supporter)	AXTN4+16BFY	3	
C - 18	Cord Stopper	AC62ETEZU01	1	
C - 19	Screw	AXTN4+16BFY	2	
C - 20	Rubber Protector	AC51E4GZU01	1	
C - 21	Power Cord	AC94EAPPZU00	1	
C-22	Handle Screw	AMC73B-V30	1	
C - 23	Screw (Grounding) Motor Handle Fitting	AXTN4+E10FFY	2	
C - 24	Stopper, Wheel	AC74SUSZ00	1	
C - 25	Washer	AXWG6E115FY	2	
C-26	Wheel P - 7 2. ^	AMC01C-V0ZU0	2	
C - 27	Wire Nut	AMC-ICTCE23	2	
C - 28	Roller Shaft	AC16CXVZ00	1	
C - 29	Switch Cover	AC03ETD1V07	1	
C - 30	Ornamental Plate	AC21TARGZ00	1	
C - 31	Screw	AXTN4+16BFY		
C - 32	Packing (Dust Container)	AMC66K-V30J		
C - 33	Packing (Indicator)	AMC09M-V30	1	
C - 34	Switch - On/Off	AMC414-7938	1	
C - 35	Nozzle Hose	AC34PTDZU01	1	
C - 36	Plastic Shaft	AMC25S-V31W	1	
C - 37	Connection Cord	AC64ETDZVU0	1	
C - 38	Dust Bag Type U6	AC16KJYZ00	1	
C - 39	Screw (Suction Inlet Packing)	AXTN4+16BFY		
C - 40	Packing (Left)	AC40AYUZV00	1	
C - 41	Packing (Right)	AC39AYUZV00	1	
C - 42	Screw (Upper Cord Hook)	AC68AZAZ00		<i>P - 7 7 OIZ,</i>
C - 43	Cord Stopper	AMC62E-M10	1	
C - 44	Handle	AC64BTEZ00	1	
C - 45	Handle Grip	AC50BV1ZV06	1	
C - 46	Upper Cord Hook (Metal)	AC53ETEZ00	1	<i>Y - 7 e a w</i>
C - 47	Lead Wire	AC44GTDZU00	1	
C - 48	Tie Cable	AMC596-702	1	
C - 49	Label (Wet Surface)	AC33ZYRZ0K	1	

EXPLODED VIEW (MOTOR UNIT)... [D] BLOCK

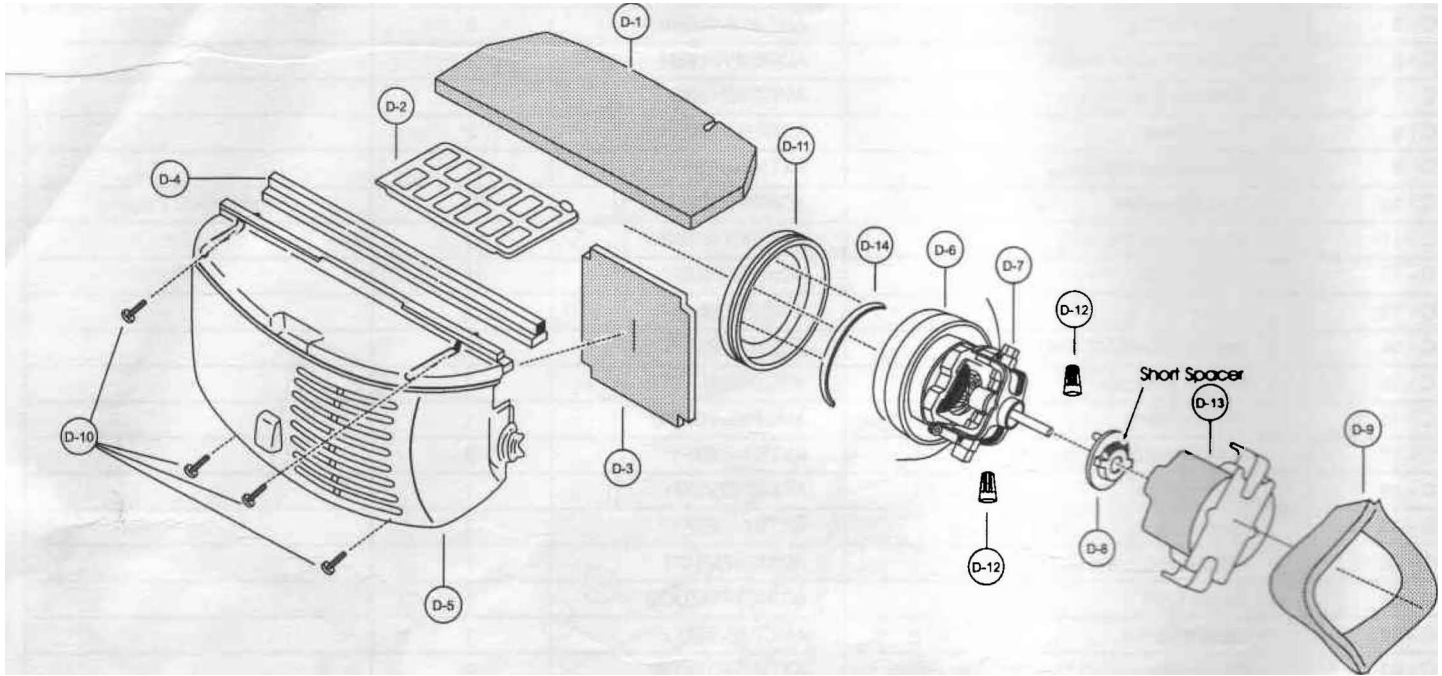

PARTS LIST (MOTOR UNIT)... [D] BLOCK

Ref. No.	Part Name & Description	Part No.	Quantity	Remarks
D-1	Secondary Filter	AMC30K-V31 (%oZZ>	1	
D-2	Filter Supporter	AMC32K-V00	1	
D-3	Rear Cover Packing	AMC02L-V30	1	
D-4	Motor Case Packing	AC19FV3ZV06	1	
D-5	Motor Case	AC09FV34V007	1	
D-6	Fan Motor Unit	AC92FTD10U 1,0 (1 ^	1	
D-7	Carbon Brush (Set)	AMC27F-REZ0000	1	(Set)
D-8	Motor Support Rubber (Rear)	AC03FTDZ00	1	Incl. Short Spacer
D-9	Noise Suppressor	AMC99G-L310X	1	
D-10	Screw	AXTN4+16BFY		
D-11	Motor Support Rubber (Front)	AMC02F-D40	1	
D-12	Wire Nut	AMC-ICTCE23		
D-13	Motor Cover	AMC93F-TEZ0U00	1	
D-14	Spacer; Long	AC53MTEZ00	1	