

This Owner's Manual is provided and hosted by Appliance Factory Parts.

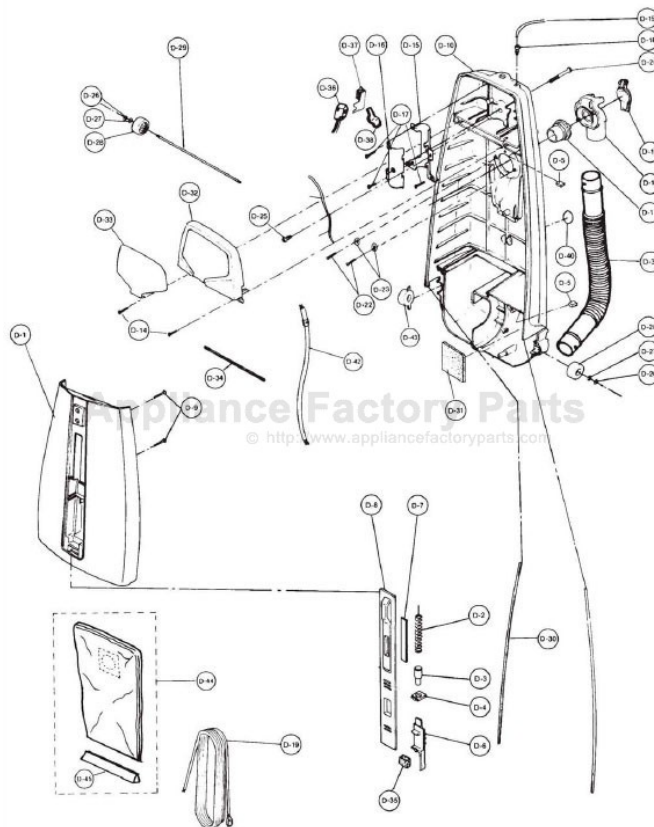

PANASONIC MC-6647 Owner's Manual

[Shop genuine replacement parts for PANASONIC
MC-6647](#)



[Find Your PANASONIC Vacuum Cleaner Parts - Select From 605 Models](#)

----- Manual continues below -----

PANASONIC

Original & Replacement

Model 6640, 6647

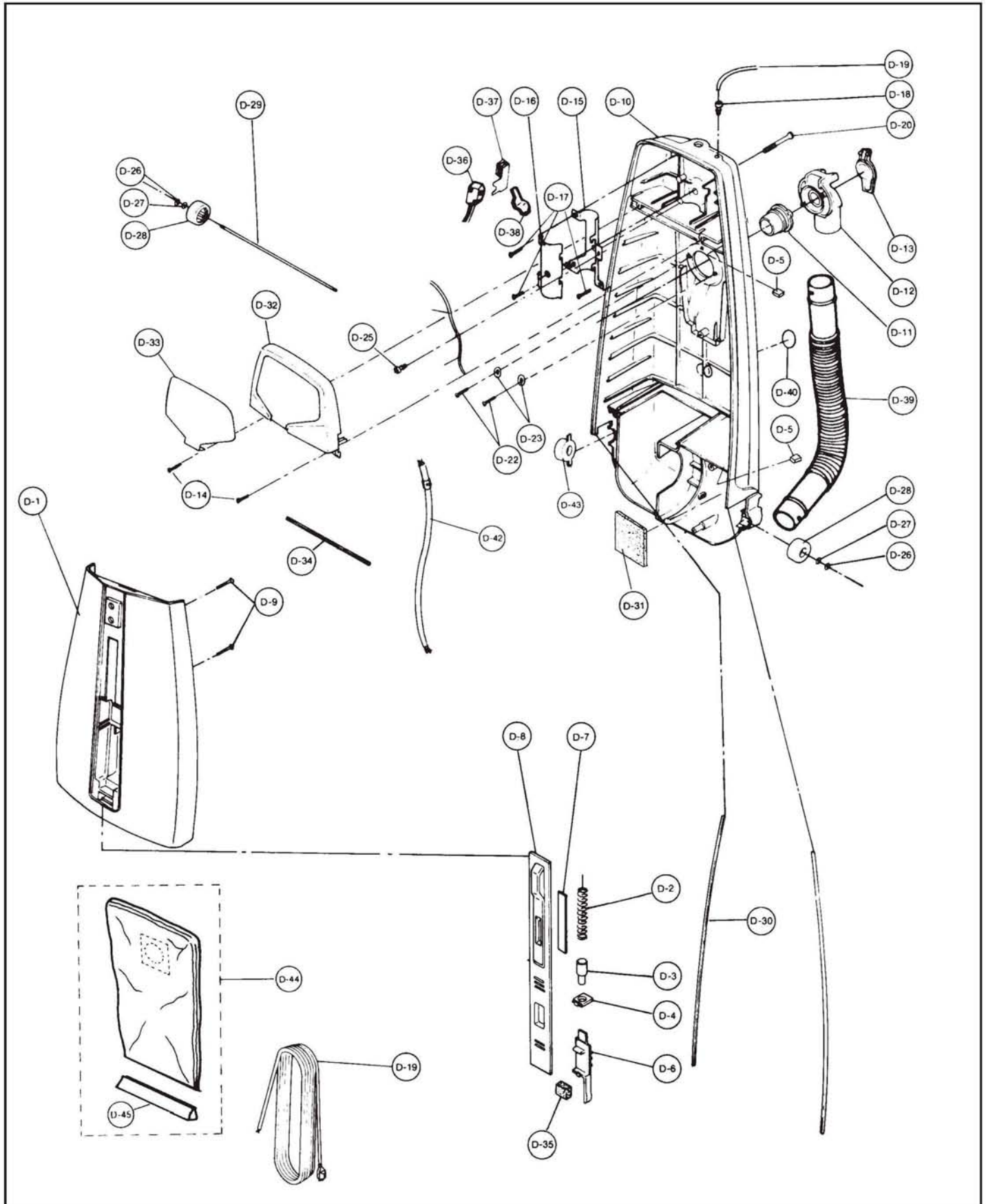

PARTS LIST (DUST COMPARTMENT, DUST COVER)

KEY	PART NO.	DESCRIPTION	KEY	PART NO.	DESCRIPTION
D-1	P-75530	Dust Cover, 6640	D-25	P-XTN4+C20FY	Screw (Connection Cord)
D-1	P-60K-V404	Dust Cover, 6647	D-26	P-77115	E-Clip
D-2	P-04M-1L0	Indicator Spring	D-27	P-XWG6	Washer
D-3	P-97M-V30	Indicator Lead	D-28	P-71060	Roller, 6640
D-4	P-20M-V30	Indicator Lead Supporter	D-28	P-71125	Roller, 6647
D-5	P-81A-1L0	Tight Packing	D-29	P-71370	Roller Shaft
D-6	P-06M-V30	Suction Control Lever, 6640	D-30	P-66K-V30K	Dust Box Packing
D-6	P-06M-V30V	Suction Control Lever, 6647	D-31	P-18300	Packing
D-7	P-08M-V30	Indicator Window	D-32	P-03E-V30R	Switch Cover, 6640
D-8	P-01H-V40Q	Front Cover, 6640	D-32	P-03E-9G04	Switch Cover, 6647
D-8	P-01H-BH0VU	Front Cover, 6647	D-33	P-21T-1L0	Ornamental Plate, 6640
D-9	P-77010	Screw (Dust Cover)	D-33	P-21T-BH00U	Ornamental Plate, 6647
D-10	P-75270	Dust Compartment	D-34	P-73K-V30K	Dust Cover Packing
D-11	P-75418	Suction Inlet Packing	D-35	P-09M-V30	Indicator Packing
D-12	P-75680	Suction Inlet, 6640	D-36	P-34150	Main Switch
D-12	P-60H-F709	Suction Inlet, 6647	D-37	P-45E-V30	Terminal Cover
D-13	P-75650	Cover, 6640	D-38	P-15E-V30	Switch Lever
D-13	P-75625	Cover, 6647	D-39	NLA	Nozzle Hose 6640 (Order P-73655)
D-14	P-77010	Screw (Switch Cover)	D-39	P-73655	Nozzle Hose 6647
D-15	P-53B-1L0	Handle Supporter	D-40	P-05T-F70Q	Sticker
D-16	P-69B-V30	Handle Fitting	D-41	P-46Z-V30	Partition Board, 6640 (Not Shown)
D-17	P-77010	Screw (Handle Supporter)	D-42	P-64E-1L0	Connection Cord
D-18	P-62E-M10	Wire Bushing	D-43	P-25S-V31W	Plastic Shaft
D-19	P-94E-1L00U	Power Cord	D-44	P-MC161C	Dust Bag (Cloth)
D-20	P-77045	Handle Screw	D-44	PR-1225	Cloth Bag, Ass'y
D-21	P-75420	Bag Supporter, Old Syle Not Shown	D-44	P-MC115P	Paper Bag, Type U 3 Pk
D-22	P-77030	Screw (Bag Supporter)	D-44	PR-14005	Paper Bag, Type U 3 Pk
D-23	P-77120	Washer	D-45	P-75430	Dust Bag Supporter
D-24	P-75910	Spacer, Old Syle Not Shown			

PARTS LIST (HANDLE)

KEY	PART NO.	DESCRIPTION
E-1	P-70261	Handle Grip Right, 6640
E-1	P-70263	Handle Grip Right, 6647
E-2	P-70262	Handle Grip Left, 6640
E-2	P-70264	Handle Grip Left, 6647
E-3	P-70130	Handle
E-4	P-34820	Switch Window, 6640
E-4	P-93P-1G0KU	Switch Window, 6647
E-5	P-73880	Switch Knob, 6640
E-5	P-69G-V30V	Switch Knob, 6647
E-6	P-77010	Screw (Handle Grip)
E-7	NLA	Upper Cord Hook, 6640
E-7	NLA	Upper Cord Hook, 6647
E-8	P-77010	Screw (Upper Storage Hook)
E-9	P-73885	Handle Lever

NLA = No Longer Available

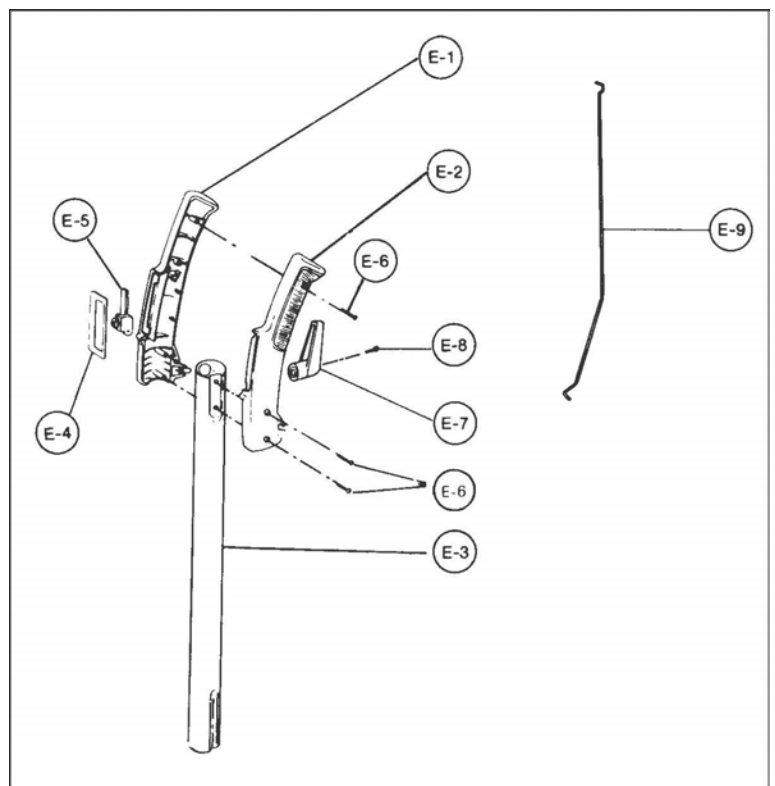

PANASONIC

Original & Replacement

Model 6640, 6647

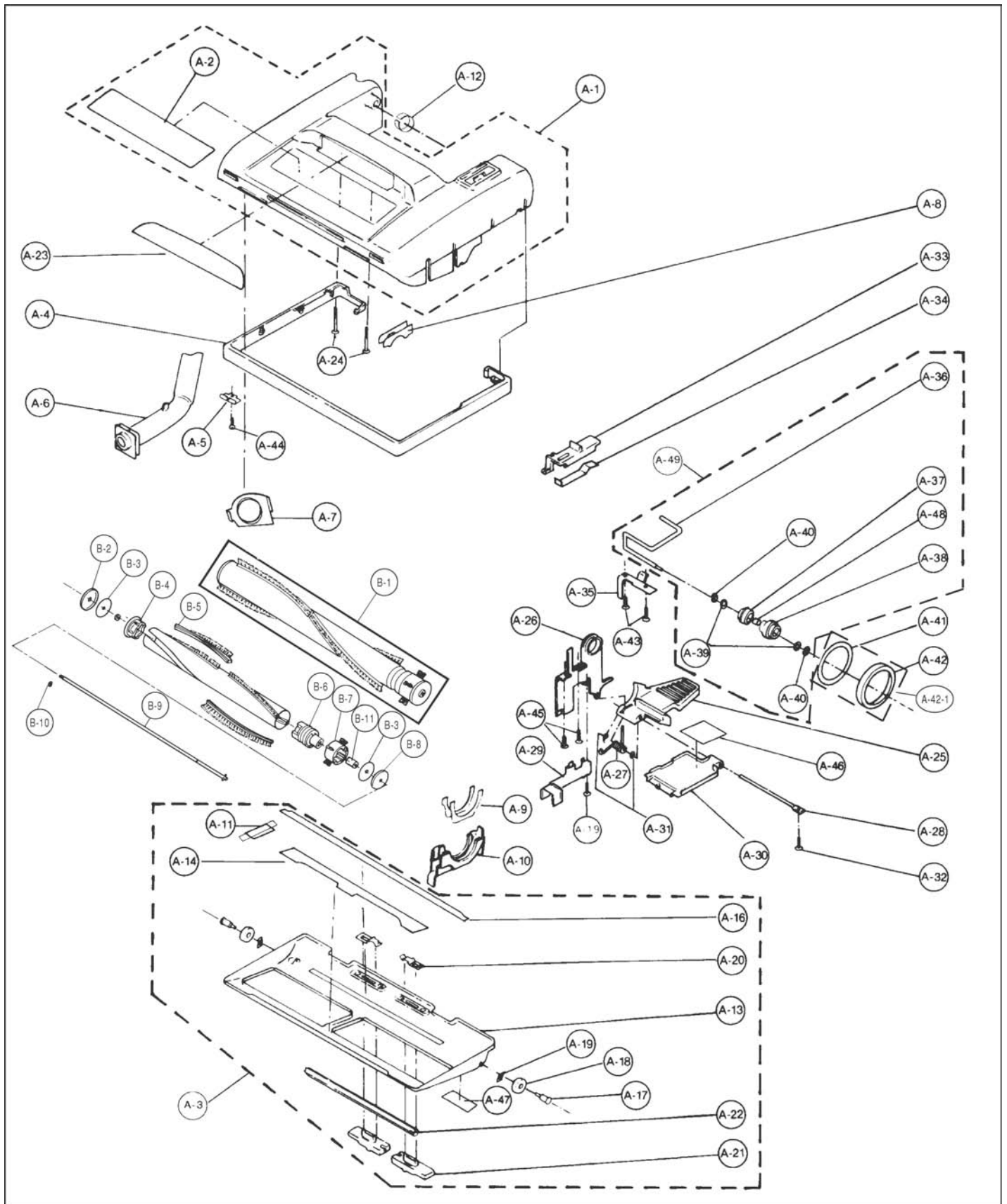

Original & Replacement **PANASONIC**

Model 6640, 6647

PARTS LIST (NOZZLE HOUSING)

KEY	PART NO.	DESCRIPTION
A-1	NLA	Nozzle Housing, 6640
A-1	P-73087	Nozzle Housing, 6647
A-2	P-02T-1L0	Top Mark, 6640
A-2	P-02T-BH00U	Top Mark, 6647
A-3	P-76030	Lower Plate Unit
A-4	P-74045	Furniture Guard, 6640
A-4	P-76046	Furniture Guard, 6647
A-5	P-27S-V30	Hose Fitting Plate
A-6	P-73435	Nozzle Pipe
A-7	P-73450	Brush Holder
A-8	P-76450	Tight Packing
A-9	P-75150	Body Packing
A-10	P-76325	Belt Cover
A-11	P-76140	Packing, Lower Plate (Right)
A-12	P-02C-1L0	Body Supporter
A-13	P-76035	Lower Plate
A-14	P-76125	Packing, Lower Plate (Front)
A-15	P-26A-V30	Screw (Frame) Not Shown
A-16	P-76142	Packing; Lower Plate (Back)
A-17	P-76845	Floor Nozzle Roller Shaft
A-18	P-76841	Floor Nozzle Roller
A-19	P-77150	Push On Spring Nut
A-20	P-76870	Stop Latch Spring
A-21	P-76415	Latch
A-22	P-76900	Floor Nozzle Rubber
A-23	P-21H-1L0R	Window, 6640
A-23	P-21H-1L04	Window, 6647
A-24	P-68A-V30	Screw (Nozzle Housing)
A-25	P-73726	Pedal
A-26	P-73419	Frame
A-27	P-77207	Pedal Spring
A-28	P-73741	Pedal Shaft
A-29	P-73745	Guide Lever
A-30	P-73430	Rear Belt Cover
A-31	P-77110	E-Clip
A-32	P-77010	Screw (Pedal Shaft)
A-33	P-73740	Selector Lever, 6640
A-33	P-18R-V30V	Selector Lever, 6647
A-34	P-73860	Selector Spring
A-35	P-59D-V30	Fitting Board

KEY	PART NO.	DESCRIPTION
A-36	NLA	Idler Pulley Shaft
A-37	NLA	Pulley
A-38	P-73415	Idler Pulley
A-39	P-77116	Washer
A-40	P-77115	E-Clip
A-41	HR-1011	Belt, Round UB2
A-42	P-MC245B	Belt, Flat 2 Pk
A-42	PR-1000	Belt, Flat UB3
A-42-1	P-MC241B	Belt, 1 Round/1 Flat UB2/UB3 2 Pk
A-43	P-77030	Screw (Fitting Board)
A-44	P-77010	Screw (Hose Fitting Plate)
A-45	P-77030	Screw (Frame)
A-46	P-07Z-V30	Caution Label (A)
A-47	P-08Z-V30	Caution Label (B)
A-48	P-74S-1L0	Spacer
A-49	NLA	Pulley Ass'y

PARTS LIST (AGITATOR ASSEMBLY)

KEY	PART NO.	DESCRIPTION
B-1	P-20040	Agitator Ass'y
B-1	PR-2010	Brushroll, 14" Metal
B-2	NLA	End Cap Left
B-2	PR-2052	End Cap, Non Pulley End
B-3	NLA	Filter
B-3	PR-2066	Filter, Brushroll
B-4	P-20840	Brushroll Holder
B-4	PR-2058	Brushroll Holder, W/Bearing
B-5	P-22020	Brush Strip Set 4 PC
B-5	PR-2215	Brush Strip, Pair
B-6	P-20656	Agitator Pulley
B-6	PR-2062	Brushroll Pulley, W/Bearing
B-7	NLA	Brush Holder
B-7	PR-2056	Edge Cleaning Brush
B-8	P-20517	End Cap Right
B-9	P-20610	Agitator Shaft
B-10	P-77110	E-Clip
B-11	P-20735	Spacer

PARTS LIST (MOTOR HOUSING)

KEY	PART NO.	DESCRIPTION
C-1	NLA	Motor Case, 6640
C-1	NLA	Motor Case, 6647
C-2	P-18300	Rear Cover Packing
C-3	P-19F-V30K	Motor Case Support Rubber
C-4	P-18420	Filter Supporter
C-5	P-18030	Filter
C-5	PR-1810	Filter, Motor Housing
C-6	NLA	Motor
C-7	P-63000	Carbon Brush (2 PCS)
C-8	P-76925	Motor Support Rubber (Front)
C-9	P-76930	Motor Support Rubber (Rear)
C-10	P-18705	Noise Suppressor
C-11	P-44G-V00	Lead Wires With AMP Terminal
C-12	P-XSN4+8S	Screw (Ground Wire)
C-13	P-77030	Screw (Motor Case)

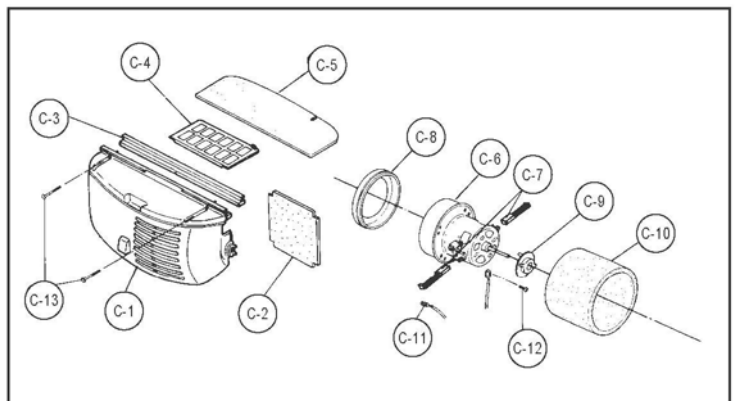

NLA = NO LONGER AVAILABLE