

This Owner's Manual is provided and hosted by [Appliance Factory Parts](#).

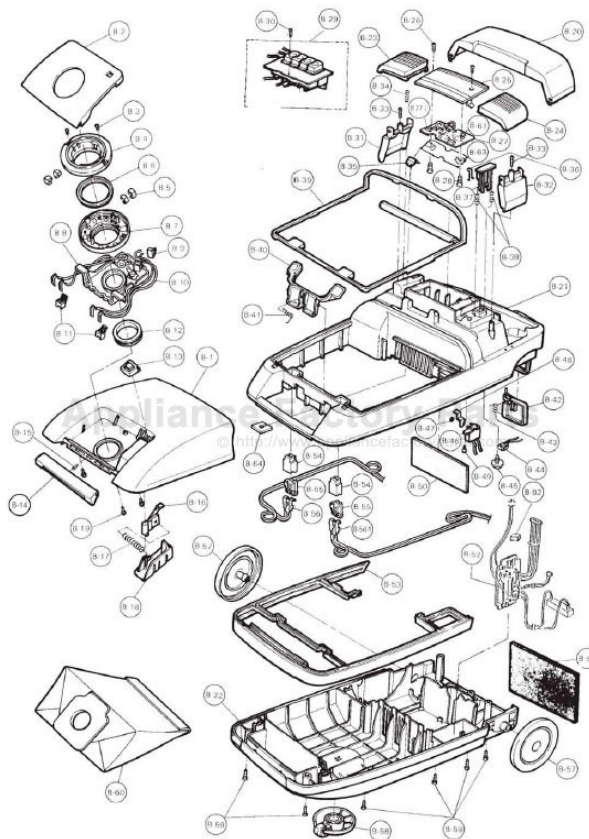

PANASONIC MC-9510 Owner's Manual

[Shop genuine replacement parts for PANASONIC
MC-9510](#)



[Find Your PANASONIC Vacuum Cleaner Parts - Select From 605 Models](#)

----- Manual continues below -----

PANASONIC

Original & Replacement

Model 9510, 9520, 9527, 9530, 9537, 9540

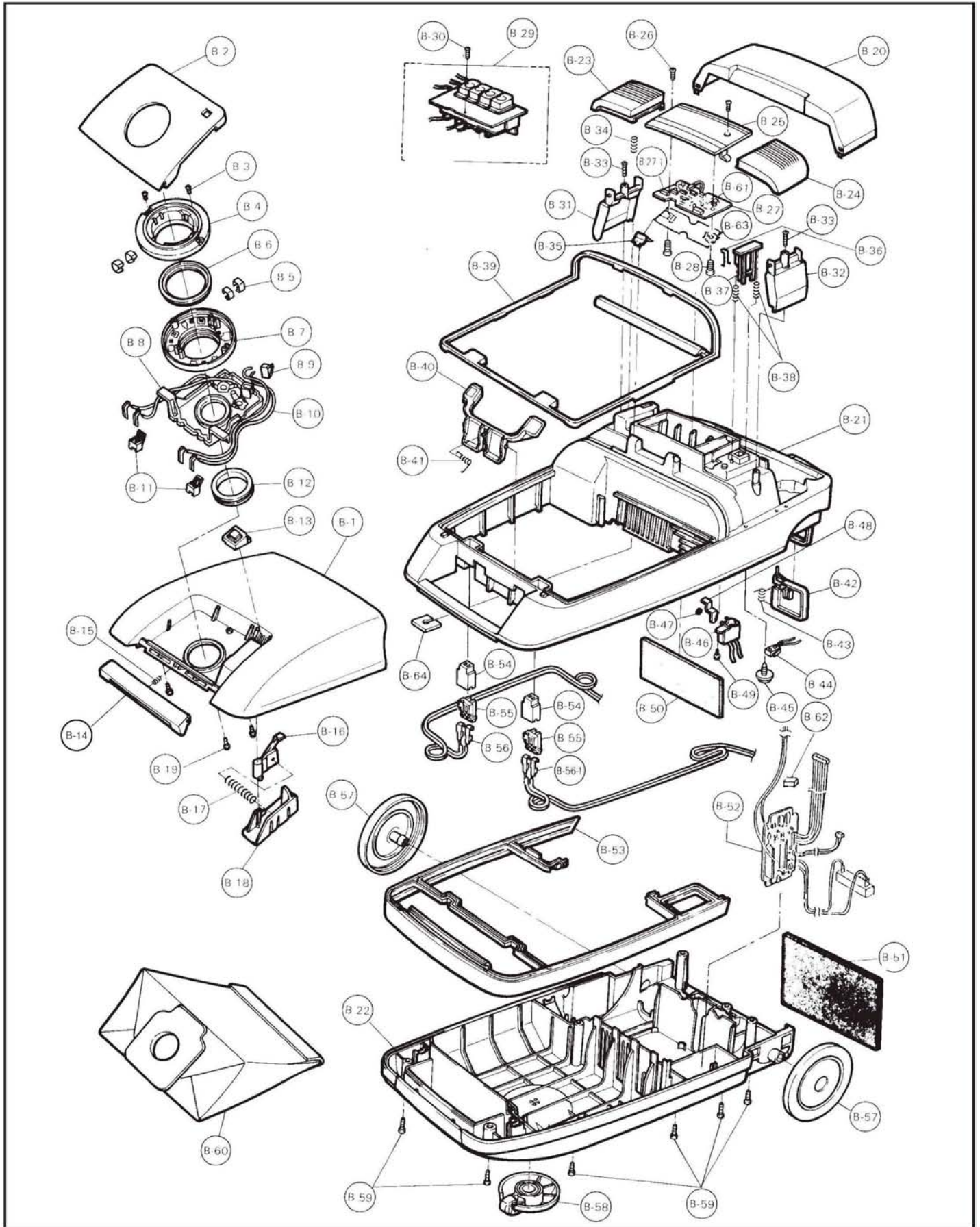

Original & Replacement **PANASONIC**

PARTS LIST (BODY UNIT)

Model 9510, 9520, 9527, 9530, 9537, 9540

KEY	PART NO.	DESCRIPTION	KEY	PART NO.	DESCRIPTION
B-1	P-60K-4P0VU	Dust Cover, 9527/9537	B-43	P-33L-4P0	Spring (Blower Cover)
B-1	P-60K-4P0JU	Dust Cover, 9510/9520/9530/9540	B-44	P-AH16829	Blower Switch,
B-2	P-25K-4P0VU	Front Cover, 9527/9537			9510/9520/9530/9540
B-2	P-25K-4P0J	Front Cover, 9510/9520/9530	B-45	P-38N-4S0	Screw (Blower Switch),
B-2	P-25K-4P0JU	Front Cover, 9540			9510/9520/9530/9540
B-3	P-XTN35+12B	Screw (Connection Upper)	B-46	P-34153	ON/OFF Switch
B-4	P-60H-4P0K	Connection Upper	B-47	P-XLPMC4	Push Nut
B-5	NLA	Terminal (Connection Upper)	B-48	P-93D-4P0R0	Switch Indicator
B-6	P-75940	Hose Fitting Rubber	B-49	P-38N-740	Screw (ON/OFF Switch)
B-7	P-75935	Connection Lower	B-50	P-18060	Rear Filter
B-8	P-39W-4P0L	Contact Base, 9527/9537	B-51	P-18055	Filter, 9510-9527
B-8	P-39W-4P0	Contact Base, 9510/9520/9530/9540	B-51	P-18057	Filter, 9530-9540
B-9	P-AV3242619	ON/OFF Sub-Switch,	B-52	P-89V-4S0	PCB (A), 9540
		9510/9520/9530/9540	B-53	P-31A-4P0U	Furniture Guard, 9527/9537
B-10	P-34500	Terminal W/Lead Wire,	B-53	P-31A-4P0K0	Furniture Guard,
		9510/9520/9530/9540			9510/9520/9530/9540
B-11	P-45E-4P0K	Terminal Holder	B-54	P-39D-4P0K	Terminal Holder
B-12	P-19K-4P0	Dust Bag Fitting (Rubber)	B-55	P-77B-4P0K	Mounting Terminal Plate
B-13	P-08M-4P000	Window, 9510-9537	B-56	P-66A-4P00U	Terminal W/Lead Wire, 9510-9537
B-13	P-08M-4S0J	Front Cover Lid, 9540	B-56	P-66A-4S00U	Terminal W/Lead Wire, 9540
B-14	P-17M-4P0V	Dust Cover Catch, 9527/9537	B-56-1	P-67A-4S00U	Terminal W/Lead Wire, 9540
B-14	P-75300	Dust Cover Catch,	B-57	P-71330	Wheel 4 1/2" Diameter
		9510/9520/9530/9540	B-58	NLA	Caster
B-15	P-77212	Spring (Dust Cover Catch)	B-59	P-77030	Screw (Ftr Lower Body)
B-16	P-03M-4P0R	Indicator	B-60	P-MC125P	Dust Bag (Paper 3 pcs.)
B-17	P-04M-4P0	Spring (Indicator), 9510	B-60	PR-1425	Paper Bag, Type C3 3 Pk
B-17	P-04M-4Q0	Spring, 9520-9540	B-61	P-LN0401RP2	LED (Vac Gauge), 9540
B-18	P-17M-4P0V	Vac Gauge Cover, 9527/9537	B-62	P-81A-4S0	Packing, 9540
B-18	P-17M-4P0J	Vac Gauge Cover,	B-63	P-23E-4S0	Insulation Pack, 9540
		9510/9520/9530/9540	B-64	P-11E-5H0	Packing (Upper Body), 9520-9540
B-19	P-77030	Screw (Dust Cover)		NLA	Thermo Protector,
B-20	NLA	Tool Storage Cover, 9527/9537			(Not Shown) 9520/9537
B-20	NLA	Tool Storage Cover,		P-62D-4Q000	Packing (Power Control Switch)
		9510/9520/9530/9540			(Not Shown), 9510-9537
B-21	P-02A-4P0K	Upper Body, 9510-9537			
B-21	P-02A-4S0K	Upper Body, 9540			
B-22	NLA	Lower Body W/Furniture Guard			
B-23	P-46N-4P0K	Cord Rewind Button			
B-24	P-05E-4P0K	ON/OFF Switch Button			
B-25	P-92A-4P0	Ornamental Plate, 9510			
B-25	P-92A-4Q0	Ornamental Plate, 9520			
B-25	P-92A-4M0	Ornamental Plate, 9527			
B-25	P-92A-4R0	Ornamental Plate, 9530			
B-25	P-92A-BK00U	Ornamental Plate, 9537			
B-25	P-92A-4S0	Ornamental Plate, 9540			
B-26	P-XTN3+12B	Screw (Ornamental Plate)			
B-27	P-34405	PCB (B), 9540			
B-27-1	P-LN0202GP3	LED (PCB {B}), 9540			
B-28	P-XTN3+8B	Screw (PCB {B}), 9540			
B-29	P-34160	Power Control Switch, 9527/9537			
B-29	NLA	Power Control Switch, 9520/9530			
B-30	P-XTN3+12B	Screw (Power Control Switch),			
		9520/9537			
B-31	P-48N-4P0V	Brake Cover, 9527/9537			
B-31	P-48N-4P0J	Brake Cover, 9510/9520/9530/9540			
B-32	P-03E-4P0V	Switch Cover, 9527/9537			
B-32	P-03E-4P0J	Switch Cover, 9510/9520/9530/9540			
B-33	P-XTN3+12B	Screw (B-31, B-32)			
B-34	P-71N-4P0	Spring (Cord Rewind Button)			
B-35	P-71K-4P0	Leaf Spring			
B-36	P-34925	Indicator Lever			
B-37	P-72435	Pedal Spacer			
B-38	P-77210	Spring (Pedal Spacer)			
B-39	P-73K-4P0L	Dust Box Packing, 9527/9537			
B-39	P-73K-4P0K	Dust Box Packing, 9510/9520/9530			
B-39	P-73K-4S0K	Dust Box Packing, 9540			
B-40	P-23K-4P0L	Dust Bag Holder, 9527/9537			
B-40	P-23K-4P0K	Dust Bag Holder,			
		9510/9520/9530/9540			
B-41	P-46H-4P0	Spring (Dust Bag Holder)			
B-42	P-29L-4P0K	Blower Cover			

PARTS LIST (CORD REEL UNIT)

KEY	PART NO.	DESCRIPTION
C-1	P-30760	Cord Reel Unit, 9510
C-1	NLA	Cord Reel Unit, 9527
C-1	NLA	Cord Reel Unit, 9520/9530/9540
C-1	P-30757	Cord Reel Unit, 9537
C-2	P-98N-F2U	Power Cord W/Rail Base, 9510
C-2	P-98N-AM0VU	Power Cord W/Rail Base, 9527
C-2	P-98N-4R00U	Power Cord W/Rail Base,
		9520/9530/9540
C-2	P-98N-4R0VU	Power Cord W/Rail Base, 9537
C-3	P-94N-4P0	Brake Lever
C-4	P-47N-B80	Brake Spring
C-5	P-19N-4P00U	Contact Base Unit, 9510
C-5	P-75685	Contact Base Unit, 9520-9540
C-6	P-36050	Body Partition
C-7	P-77010	Screw (Body Partition)
C-8	P-77010	Screw (Contact Base)

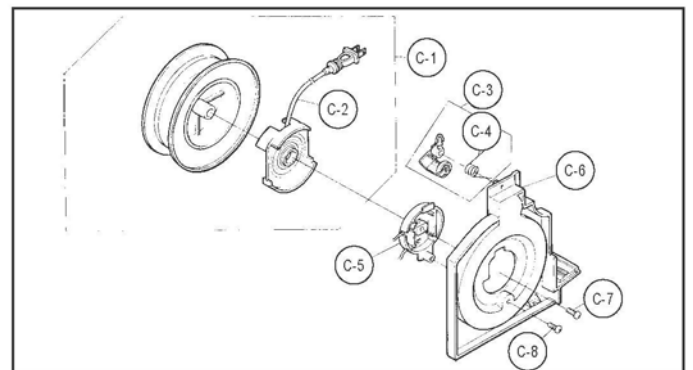

PANASONIC Original & Replacement

Model 9510, 9520, 9527, 9530, 9537, 9540

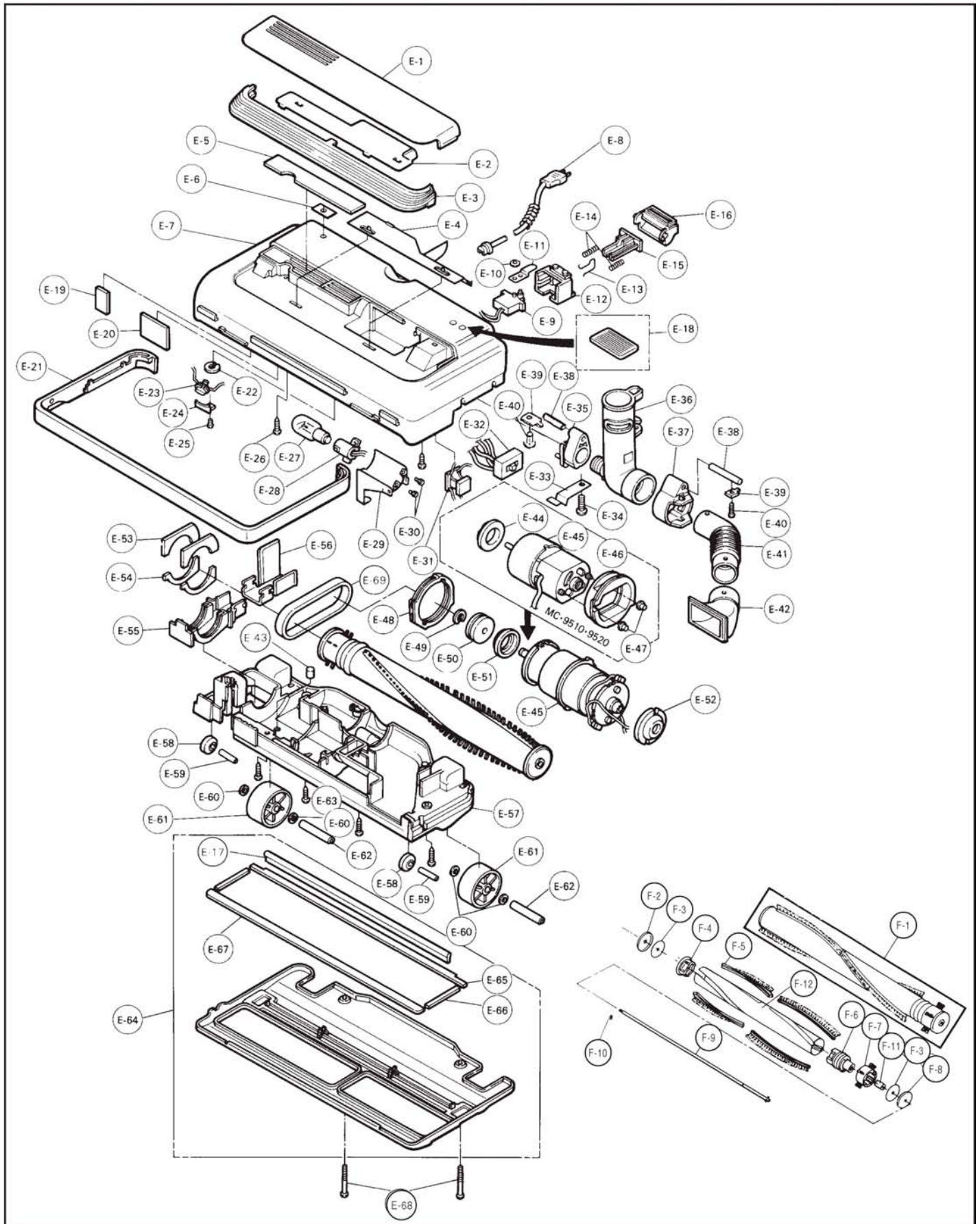

Original & Replacement **PANASONIC**

Model 9510, 9520, 9527, 9530, 9537, 9540

PARTS LIST (POWER NOZZLE)

KEY	PART NO.	DESCRIPTION	KEY	PART NO.	DESCRIPTION
E-1	P-24H-4P0K	Power Head Cover, 9510	E-48	NLA	Motor Support Rubber (Center), 9530-9540
E-1	P-24H-4Q0K	Power Head Cover, 9520	E-49	P-77115	E-Clip, 9530-9540
E-1	P-24H-AM0KU	Power Head Cover, 9527	E-50	NLA	Motor Pulley, 9530-9540
E-1	P-24H-4R0K	Power Head Cover, 9530-9540	E-51	P-14F-4R0	Motor Support Rubber (Front), 9530-9540
E-2	P-84H-4R0	Reflector Plate (Upper), 9527-9540	E-52	P-15F-4R0	Motor Support Rubber (Rear), 9530-9540
E-3	P-21H-4P0	Window Cover, 9510/9520	E-53	NLA	Tight Packing
E-3	P-21H-4R0	Window Cover, 9537	E-54	P-76755	Belt Cover Packing
E-3	P-21H-4R0K	Window Cover, 9527/9530/9540	E-55	P-59S-4P0V	Belt Cover, 9527/9537
E-4	P-86H-4R0	Reflector Plate (Lower), 9527-9540	E-55	P-72600	Belt Cover, 9510/9520/9530/9540
E-5	P-18061	Filter (Upper)	E-56	P-57S-4R0	Belt Cover (Metal), 9530-9540
E-6	P-46R-4R0	Label, 9530-9540	E-57	P-72044	Power Nozzle Lower, 9510/9520
E-7	P-72030	Body, 9510	E-57	P-03R-4P0V	Power Nozzle Lower, 9527/9537
E-7	NLA	Body, 9520	E-57	P-72100	Power Nozzle Lower, 9530/9540
E-7	NLA	Body, 9527	E-58	P-76841	Power Nozzle Roller
E-7	NLA	Body, 9537	E-59	P-71380	Roller Shaft
E-7	P-72050	Body, 9530/9540	E-60	P-XWG6	Washer
E-8	NLA	Cord Unit, 9510/9520/9530/9537	E-61	P-71020	Roller (Large), 9510/9520/9530/9540
E-8	NLA	Cord Unit, 9527/9540	E-61	P-01C-F00K	Roller (Large), 9527/9537
E-9	P-34153	ON/OFF Switch, 9520-9540	E-62	P-16C-4P0	Roller Shaft (Large Roller)
E-10	P-XPLMC4	Push Nut, 9520-9540	E-63	P-77030	Screw (Power Nozzle Lower)
E-11	P-93D-4Q0R	Switch Indicator, 9520-9540	E-64	NLA	Bottom Plate Unit
E-12	P-03E-4Q0	Switch Holder, 9520-9540	E-65	P-74A-4P0	Packing (Rear)
E-13	P-34925	Switch Lever, 9520-9540	E-66	P-39A-4P0	Packing (Side)
E-14	P-77210	Spring (Pedal Spacer), 9520-9540	E-67	P-19A-4P0	Packing (Front)
E-15	P-72435	Pedal Spacer, 9520-9540	E-68	P-77017	Screw (For Bottom Plate)
E-16	P-34905	Switch Pedal, 9520-9540	E-69	P-MC220B	Belt, 9510-9527
E-17	P-76910	Nozzle Rubber	E-69	ER-1050	Belt, Type CB 9510-9527
E-18	P-42A-4P0J	Pedal Cover, 9510	E-69	P-MC225B	Belt, 9530-9540
E-19	NLA	Filter (Side)			
E-20	P-37K-4P0	Filter (Front)			
E-21	P-74060	Furniture Guard			
E-22	P-04E-4R0	Protector Button, 9530-9540			
E-23	P-98W-4R0	Thermo Protector, 9530-9540			
E-24	P-19M-4R0	Protector Support, 9530-9540			
E-25	P-XTN3+8B	Screw (Protector Support), 9530-9540			
E-26	P-77030	Screw (Power Nozzle Lower)			
E-27	FA-3500	Bulb, 25 Watt			
E-28	P-93H-4R00U	Lamp Holder, 9527-9540			
E-29	P-85H-4R0	Partition Plate, 9527-9540			
E-30	P-XYN3+C6FYS	Screw (Partition Plate), 9527-9540			
E-31	NLA	P.C.B., 9527-9540			
E-32	NLA	Reverse Switch, 9530-9540			
E-33	P-70N-4R0	Leaf Spring, 9530-9540			
E-34	P-77010	Screw (Leaf Spring), 9530-9540			
E-35	NLA	Pipe Insert (Right), 9530-9540			
E-36	NLA	Wand Connection			
E-37	P-72410	Pipe Insert (Left), 9530-9540			
E-38	NLA	Pipe Insert Shaft, 9530-9540			
E-39	NLA	Stopper, 9530-9540			
E-40	P-77010	Screw (Stopper), 9530-9540			
E-41	NLA	Nozzle Hose			
E-42	P-40S-4P0	Nozzle Pipe			
E-44	P-14F-4P0	Motor Support Rubber (Front), 9510-9527			
E-45	NLA	Motor, 9510-9527			
E-45	P-60510	Motor, 9530-9540			
E-46	P-16F-4P0	Motor Support Rubber (Center), 9510-9527			
E-47	P-15F-4P0	Motor Support Rubber (Rear), 9510-9527			

PARTS LIST (AGITATOR ASSEMBLY)

KEY	PART NO.	DESCRIPTION
F-1	NLA	Agitator Assembly
F-2	NLA	End Cap (Left)
F-2	PR-2052	End Cap, Pulley End W/Slot
F-3	NLA	Filter
F-3	PR-2066	Filter, Brushroll 1.5" Dia
F-4	P-20840	Agitator Holder (W/Bearing)
F-4	PR-2058	Holder, Brushroll W/Bearing
F-5	P-22020	Brush (4 Pcs.)
F-5	NLA	Brush Strip, Pair
F-6	NLA	Agitator Pulley (W/Bearing)
F-7	NLA	Brush Holder
F-7	PR-2056	Edge Cleaning Brush
F-8	P-20517	End Cap (Right)
F-9	P-57R-X60	Agitator Shaft
F-10	P-77110	E-Clip
F-11	P-74S-X60	Spacer
F-12	P-84R-V10	Agitator Cylinder

NLA = NO LONGER AVAILABLE

PANASONIC Original & Replacement

Model 9510, 9520, 9527, 9530, 9537, 9540

PARTS LIST (ATTACHMENTS)

KEY	PART NO.	DESCRIPTION
A-1	NLA	Hose Assembly, 9510/9520/9530/9537
A-1	NLA	Hose Assembly, 9527
A-1	NLA	Hose Assembly, 9540
A-2	NLA	Handle Grip Right, 9527
A-2	P-19P-4S0J	Handle Grip Right, 9540
A-3	NLA	Handle Grip Left, 9527
A-3	NLA	Handle Grip Left, 9540
A-4	NLA	Grip Cover, 9527
A-4	NLA	Grip Cover, 9540
A-5	P-34405	PCB (C) Unit, 9540
A-6	NLA	ON/OFF Sub-Switch, 9540
A-7	P-93D-4S0K	Control Plate, 9540
A-8	P-03E-4S0	Switch Cover, 9540
A-9	P-05E-4S0K	ON/OFF Switch Button, 9540
A-10	P-04E-4S0K	Control Button, 9540
A-11	P-59G-4S0	Wire (Ground), 9527/9540
A-12	P-23P-4P0J	Hose Holder, 9510/9520/9530/9540
A-12	P-23P-4P0V	Hose Holder, 9527/9537
A-13	P-27H-4P0J	Connector Unit Body, 9510/9520/9530/9540
A-13	P-27P-4P0V	Connector Unit Body, 9527/9537
A-14	P-10P-4P0J	Connection Button, 9510/9520/9530/9540
A-14	P-10P-4P0V	Connection Button, 9527/9537
A-15	P-03P-291	Spring (Connection Button)
A-16	P-29F-4P0	Terminal Holder
A-17	P-48H-4P0J	Connection Cover, 9510/9520/9530/9540
A-17	P-48H-4P0V	Connection Cover, 9527/9537
A-18	P-28P-4P0	Terminal W/Lead Wire
A-19	P-AMP34137	Wire Connector (Not Shown)
A-20	P-29E-4P0	Insulation Tube
A-21	NLA	Short Wand, 9527/9540
A-22	P-77010	Screw (Hose Grip), 9527/9540
A-23	P-XTN3516BFN	Screw (Connection Cover)
A-24	NLA	Extension Wand
A-25	P-50500	Spring W/Button
A-26	P-61L-4P0	Packing
A-27	NLA	Curved Wand, 9510/9520/9530/9537
A-28	P-50510	Suction Regulator, 9510/9520/9530/9537
A-29	NLA	Upholstery Brush
A-30	NLA	Dusting Brush
A-31	P-54020	Crevlce Tool
A-32	NLA	Floor & Wall Brush
A-33	NLA	Grip Cover, 9510/9520/9530/9537
A-34	NLA	Power Head Connector, 9527
A-34	NLA	Power Head Connector, 9540

PARTS LIST (MOTOR UNIT)

KEY	PART NO.	DESCRIPTION
D-1	NLA	Motor, 9510
D-1	NLA	Motor, 9520-9537
D-1	NLA	Motor, 9540
D-2	P-63000	Carbon Brush (2 Pcs), 9510
D-2	P-63060	Carbon Brush (2 Pcs), 9520-9540
D-3	P-73766	Motor Support Rubber (Front), 9510
D-3	P-73767	Motor Support Rubber (Front), 9520-9537
D-3	P-02F-4S0	Motor Support Rubber (Front), 9540
D-4	P-07F-1T0	Motor Support Rubber (Rear)
D-5	P-68A-1T0	Screw
D-6	P-99G-4P0	Noise Suppressor
D-7	ERF10HMJ122	1.2 K Fixed Resistor, 9540

