

This Owner's Manual is provided and hosted by [Appliance Factory Parts](#).



# PANASONIC MC-CL483 Owner's Manual

[Shop genuine replacement parts for PANASONIC  
MC-CL483](#)



[Find Your PANASONIC Vacuum Cleaner Parts - Select From 605 Models](#)

----- Manual continues below -----

# EXPLODED VIEW

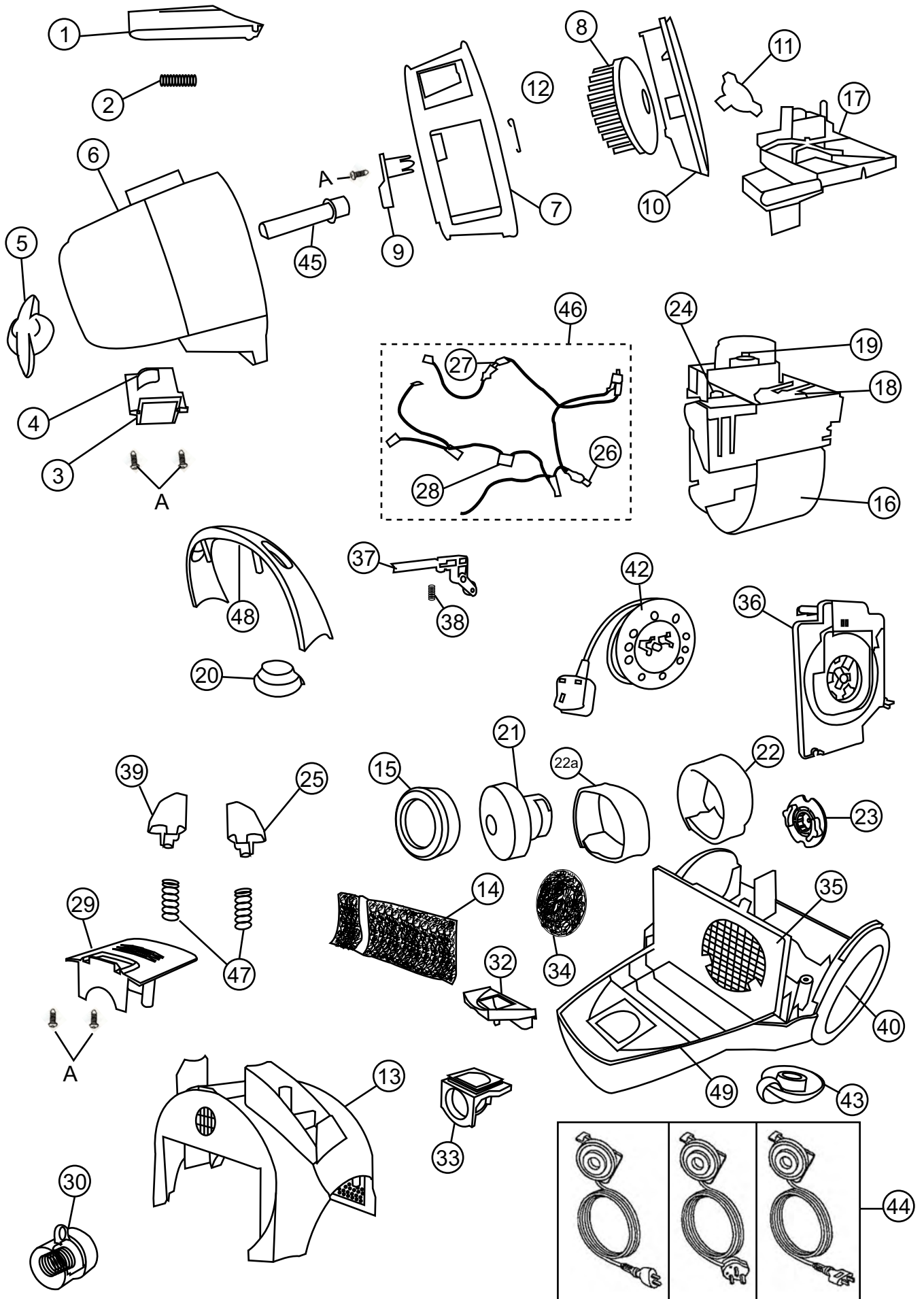

# REPLACEMENT PARTS LIST

REF. NO.	PART NAME	PART NO.	MODEL			REMARKS
			MC-CL481	MC-CL483	MC-CL485	
1	BUCKLE	YMV01D63000	1	1	1	
2	BUCKLE SPRING	YMV04D61000	1	1	1	
3	SUCTION INLET	YMV60H61000	1	1	1	
4	VALVE GROMMET	YMC50KSG000	1	1	1	
5	FILTER KNOB	YMV35K610S0	-	1	1	SILVER
5	FILTER KNOB	YMV35K610R0	1	-	-	RED
5	FILTER KNOB	YMV35K610B0	1	-	-	BLUE
6	DUST COMPARTMENT ASSY	YMV88K610S0	-	-	1	
6	DUST COMPARTMENT ASSY	YMV88K620S0	-	1	-	
6	DUST COMPARTMENT ASSY	YMV88K630B0	1	-	-	
6	DUST COMPARTMENT ASSY	YMV88K630R0	1	-	-	
7	PRE-FILTER	YMV43K61000	1	1	1	
8	FILTER UNIT	YMV95K61000	1		1	
9	FLITER PRESSER	YMV31K61000	1	1	1	
10	SLIDER SUPPORTER	YMV53K61000	1	1	1	
11	SLIDER	YMV48K61000	1	1	1	
12	SPRING FILTER	YMV49K61000	1	1	1	
13	UPPER BODY	YMV02A610S0	-	1	1	SILVER
13	UPPER BODY	YMV02A610R0	1	-	-	RED
13	UPPER BODY	YMV02A610B0	1	-	-	BLUE
14	EXHAUST FILTER	YMV02L61000	1	1	1	
15	MOTOR SUPPORT RUBBER FRONT	YMC02FQU000	-	1	1	
15	MOTOR SUPPORT RUBBER FRONT	YMC02FYX000	1	-	-	
16	MOTOR COVER	YMV63F6100	-	1	1	1800
16	MOTOR COVER	YMV63F6300C	1	-	-	1600
16	MOTOR COVER	YMV63F6300U	1	-	-	1400
17	MOTOR CASE PLATE	YMV17F6100U	-	1	1	
17	MOTOR CASE PLATE	YMV17F61000	1	-	-	
18	PCB ASSY	YMV89V6100E	-	1	1	
19	ROTARY VOLUME	YMNGWH118	-	1	1	
20	SWITCH KNOB	YMV04E61000	-	1	1	
21	MOTOR UNIT	YMV92F6200B	-	1	-	1802
21	MOTOR UNIT	YMV92F6200C	-	1	1	1804
21	MOTOR UNIT	YMV92F6200E	-	1	1	1803
21	MOTOR UNIT	YMC92FRT00C	1	-	-	1604
21	MOTOR UNIT	YMC92FSG00K	1	-	1	1401 UL
21	MOTOR UNIT	YMV92F4W00B	1	-	-	1402
21	MOTOR UNIT	YMV92F4W00C	1	-	-	1404
22	NOISE SUPPRESSOR UNIT	YMC99GMW100	1	1	1	
22a	NOISE ABSORBER SIDE	YMC20G61000	-	-	1	
23	MOTOR SUPPORT RUBBER REAR	YMV03F61000	-	1	1	1800
23	MOTOR SUPPORT RUBBER REAR	YMC03FSG000	1	1	1	1400
23	MOTOR SUPPORT RUBBER REAR	YMC03FPQ000	1	-	-	1600
24	SWITCH ON/OFF	YMC01EUF000	1	1	1	
25	SWITCH PEDAL	YMV05E61000	1	1	1	
26	THERMO PROTECTOR	YMV20W6200	1	1	1	
26	THERMO PROTECTOR	YMV20W6300	1	1	1	
27	FUSE UNIT	YMV99W62000	1	1	1	
27	FUSE UNIT	YMV99W6100U	1	1	1	
28	CAPACITOR	YMV46F61000	1	1	1	0.22
28	CAPACITOR	YMV46F62000	1	1	1	0.47
29	INDICATOR PLATE	YMV94M61000	-	1	1	SILVER ( 1800W )
29	INDICATOR PLATE	YMV94M6100K	-	1	1	SILVER ( USA )
29	INDICATOR PLATE	YMV94M6200T	-	1	-	SILVER ( 1400W )
29	INDICATOR PLATE	YMV94M6300ER	1	-	-	RED ( 1600W )
29	INDICATOR PLATE	YMV94M6300EB	1	-	-	BLUE ( 1600W )
29	INDICATOR PLATE	YMV94M63000R	1	-	-	RED ( 1500W )
29	INDICATOR PLATE	YMV94M63000B	1	-	-	BLUE ( 1500W )
29	INDICATOR PLATE	YMV94M6300TR	1	-	-	RED ( 1400W )
29	INDICATOR PLATE	YMV94M6300TB	1	-	-	BLUE ( 1400W )
29	INDICATOR PLATE	YMV94M6300CR	1	-	-	RED ( 1500W )
29	INDICATOR PLATE	YMV94M6300CB	1	-	-	BLUE ( 1500W )
30	INDICATION UNIT	YMC99MSG100	1	1	1	
32	SUCTION INLET PACKING	YMV64H61000	1	1	1	

# REPLACEMENT PARTS LIST

33	FRONT COVER	YMV01H61000	1	1	1	
34	FILTER	YMV30K61000	1	1	1	
35	FILTER SUPPORRTER	YMV32K61000	1	1	1	
36	BODY PARTITION UNIT	YMV96A63000	1	1	1	
36	BODY PARTITION UNIT	YMV96A6300U	-	-	1	
37	BRAKE LEVER UNIT	YMV94N61000	1	1	1	
38	SPRING BRAKE BUTTON	YMV71N61000	1	1	1	
39	BRAKE PEDAL	YMV04E61000	1	1	1	
40	WHEEL	YMC01CLE0V0	2	-	-	
40	WHEEL	YMV01C61000	-	2	2	SOFT WHEEL
42	CORD REEL UNIT	YMV99N61008	1	1	1	UK, MALAYSIA, H.KONG, S.ARBIA, KUWAIT
42	CORD REEL UNIT	YMV99N6100E	1	1	1	CONTINENTAL, IRAN
42	CORD REEL UNIT	YMV99N6100L	1	1	1	SWITZERLAND, SINGAPORE, M. EAST
42	CORD REEL UNIT	YMC99NYX30U	-	-	1	CANADA
42	CORD REEL UNIT	YMV99N6200S	-	1	-	SINGAPORE
42	CORD REEL UNIT	YMV99N6200P	-	1	-	THAILAND
42	CORD REEL UNIT	YMV99N6300C	1	-	-	SINGAPORE, S.ARBIA, KUWAIT
42	CORD REEL UNIT	YMV99N6300B	1	-	-	SINGAPORE, M. EAST
42	CORD REEL UNIT	YMV99N6300S	1	-	-	SINGAPORE
42	CORD REEL UNIT	YMC99NYX30B	1	-	-	THAILAND
42	CORD REEL UNIT	YMV99N6300E	1	-	-	IRAN
43	CASTER UNIT	YMV95C61000	-	1	1	SOFT ROLLER
43	CASTER UNIT	YMC95C7K100	1	-	-	
44	POWER CORD	YMV93E4Y008	1	1	1	PATELEC C3 1.0 UK
44	POWER CORD	YMC91EXQ00E	1	1	1	PATELEC E2 1.0
44	POWER CORD	YMC96ERT00L	1	1	1	PATELEC C2 1.0
44	POWER CORD	YMC97EME10K	-	-	1	TA HSING USA
44	POWER CORD	YMC97EQV30T	1	1	-	TA HSING A2 1.25 TAIWAN
44	POWER CORD	YMC93E6200S	-	1	-	TA HSING C3 1.0 SINGAPORE
44	POWER CORD	YMC97ETB00B	-	1	-	TA HSING A2 1.0 THAILAND
44	POWER CORD	YMV93E4W008	1	-	-	PATELEC C3 0.75 UK
44	POWER CORD	YMV96E4W000	1	-	-	PATELEC C2 0.75
44	POWER CORD	YMC93EYX00S	1	-	-	TA HSING C3 0.75 SINGAPORE
44	POWER CORD	YMC97EFW00B	1	-	-	TA HSING A2 0.75 THAILAND
44	POWER CORD	YMC97EFW1	1	-	-	WANDERFUL A2 0.75 THAILAND
44	POWER CORD	YMV91E4W00E	1	-	-	PATELEC E2 0.75
45	CRANK SHAFT	YMV54K61000	1	1	1	
46	LEAD WIRE UNIT	YMV69V63-OE	-	1	1	
46	LEAD WIRE UNIT	YMV69V63-OT	1	-	-	
47	SWITCH PEDAL SPRING	YMV08E61000	2	2	2	
48	HANDLE	YMV01B6100	1	1	1	
49	LOWER BODY ASSY	YMV97A61000	-	1	1	
49	LOWER BODY ASSY	YMV97A63000	1	-	-	
51	FILTER UNIT ASSY	YMC84K61000	1	1	1	
52	PRE FITER ASSY	YMC43K61000	1	1	1	
A	SCREW	XTN4+20BFJ	12	12	12	
B	SCREW	XTN4+14GJ	3	3	3	

# ATTACHMENT EXPLODED VIEW

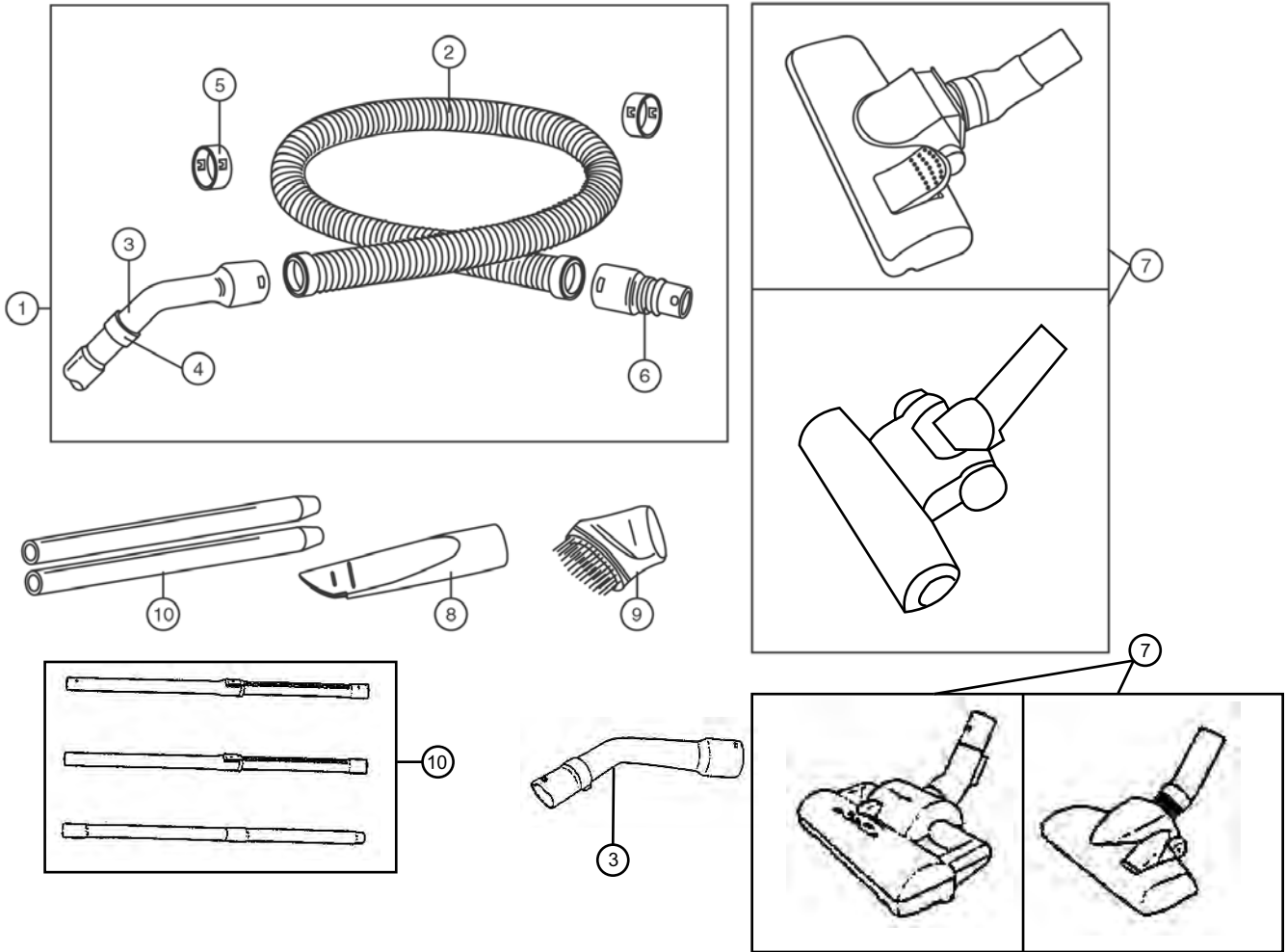

# ATTACHMENT REPLACEMENT PART LIST

REF. NO.	PART NAME	PART NO.	MODEL			REMARKS
			MC-CL481	MC-CL483	MC-CL485	
1	HOSE ASS'Y	AMC94P-6L0V0	1	1	1	
2	HOSE UNIT	AMC84P-6L0V0	1	1	1	
3	CURVED WAND	AMC30P-0R0V0	1	1	-	NO HOLE
(3)	CURVED WAND	V30P61000	-	-	1	HOLE
4	SUCTION REGULATOR	AMC54P-7K0V0	1	1	1	
5	HOSE SUPPORTER	AMC24P-0R0V0	2	2	2	
6	CONNECTION PIPE	AMC02P-0R0V0	1	1	1	
7	FLOOR NOZZEL ASS'Y	V99R62000	-	-	1	
(7)	FLOOR NOZZEL ASS'Y	YMC99RXQ000	1	1	-	
(7)	FLOOR NOZZEL ASS'Y	C99RXQ00G	-	1	-	IONIZER TURBINE
(7)	FLOOR NOZZEL ASS'Y	V99R61000	-	-	1	3 IN 1
8	CREVICE NOZZEL	YMC60RXQ000	1	1	1	
9	DUSTING BRUSH ASSY	YMC88RYX0V0	1	1	1	
10	EXTENSION WAND	AMC40P-B12V0	2	-	-	PLASTIC GREY
(10)	EXTENSION WAND	YMC40PQN000	2	2	-	METAL
(10)	EXTENSION WAND	V99P61000	-	-	1	TELESCOPIC HOLE
(10)	EXTENSION WAND	V99P62000	-	1	-	TELESCOPIC W/O HOLE