

2 EXPLODED VIEW AND PARTS LIST

2.1. Body

2.1.1. Exploded View

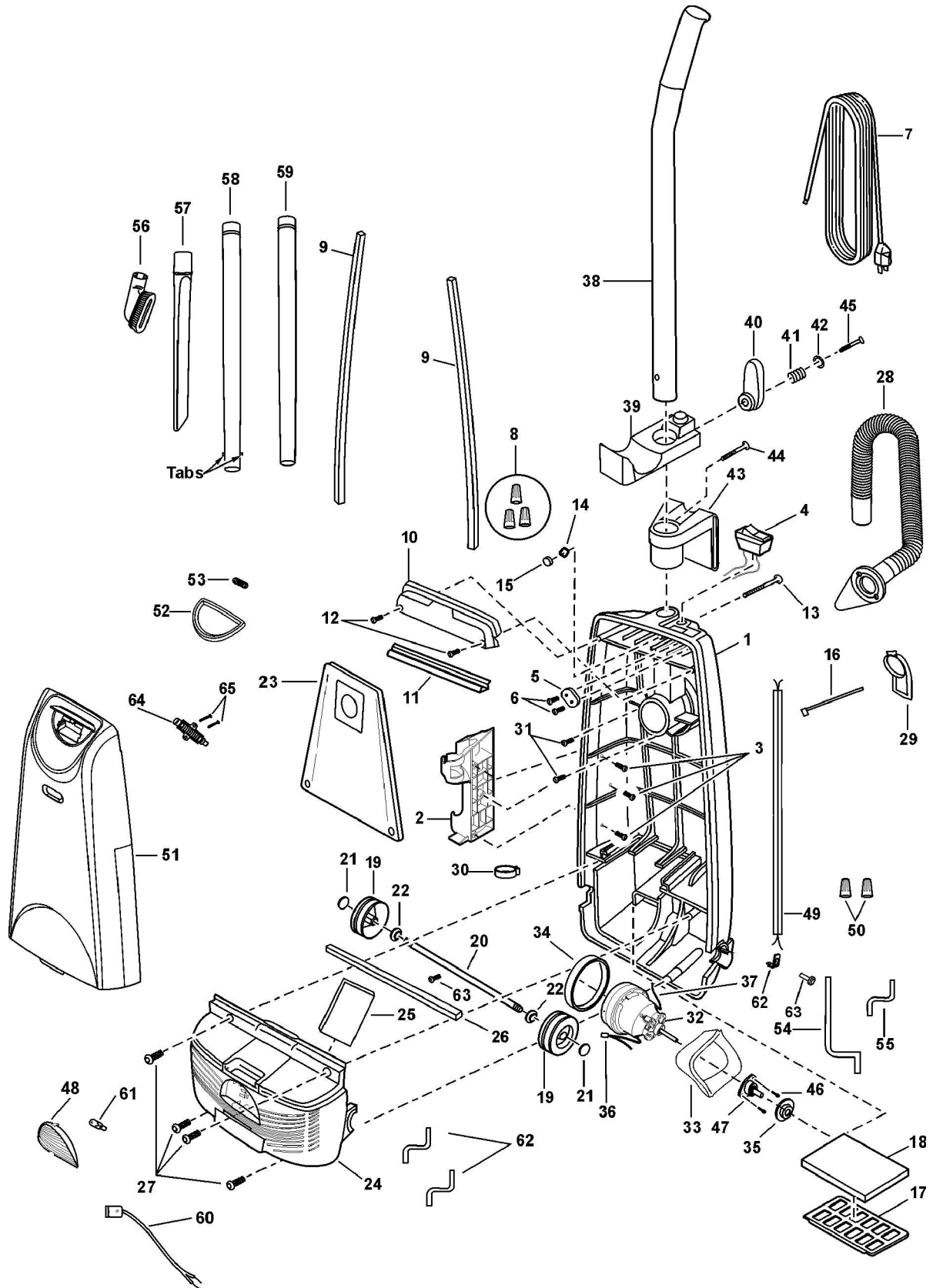

2.1.2. Parts List (Body)

Ref. No.	Part No.	Part Name & Description	Quantity	Remarks
1	AC78KDJGZV07	DUST COVER	1	INCLUDES ITEMS 54 & 55
2	AC70PJPZV07	WAND HOLDER	1	INCLUDES ITEM 3
3	AXTN4+16BFY	SCREW (WAND HOLDER)		SHIPPED 10 PER PACKAGE
4	AMC98E-V010U	SWITCH	1	INCLUDES ITEMS 5 15 & 16
5	AMC62E-J20	CORD STOPPER	1	
6	AXTN4+16BFY	SCREW (CORD STOPPER)		SHIPPED 10 PER PACKAGE
7	AC97EAACZV06	POWER CORD	1	
8	AC44DCYKZ000	WIRE CRIMP		
9	AC66KV01V06	DUST CONTAINER PACKING		SHIPPED 2 PER PACKAGE
10	AC03EDEVZV07	SWITCH COVER	1	INCLUDES ITEMS 5 15 & 16
11	AC73KV0ZV06	SWITCH COVER PACKING	1	
12	AXTN4+16BFY	SCREW (SWITCH COVER)		SHIPPED 10 PER PACKAGE
13	AMC73B-V00	HANDLE SCREW	1	
14	AMP21B-170	NUT	1	SHIPPED 10 PER PACKAGE
15	AC61LAGMZ00	PACKING	1	
16	AMC596-702	CABLE TIE	1	
17	AMC32K-V00	FILTER SUPPORTER	1	
18	AC37KAAEZ00	HEPA FILTER	1	
19	AC99CBSAZV06	WHEEL		SHIPPED 2 PER PACKAGE
20	AC16CDEXZ000	SHAFT (WHEEL)	1	
21	AC74SUSZ00	STOPPER (WHEEL)		SHIPPED 10 PER PACKAGE
22	AXWG6E115FY	WASHER (WHEEL)		SHIPPED 10 PER PACKAGE
23	AC16KDABZ000	DUST BAG	1	
24	AC09FDKVZR03	MOTOR CASE	1	
25	AC02LDKVZ000	REAR COVER PACKING	1	
26	AC19FARSZV06	MOTOR CASE PACKING	1	
27	AXTN4+20BFY	SCREW (MOTOR CASE)		SHIPPED 10 PER PACKAGE
28	AC84PJPZV06	HOSE ASSEMBLY	1	
29	AC02HYUZV06	COVER	1	
30	AC53RJPZV06	HOSE RING	1	
31	AXTN4+16BFY	SCREW (HOSE)		SHIPPED 10 PER PACKAGE
32	AC92FBSKZ000	FAN MOTOR	1	INCLUDES ITEMS 36 & 37
33	AC99GAMMZ00	NOISE SUPPRESSOR	1	
34	AMC02F-E00	MOTOR SUPPORT (FRONT)	1	
35	AC03FAFYZ000	MOTOR SUPPORT (REAR)	1	
36	AC99WDKXZ000	LEAD WIRE (FUSE)	1	
37	AC38GARTZ000	LEAD WIRE	1	
38	AC64BDKXZ000	HANDLE	1	
39	AC23FJPLV07	HOSE HOLDER	1	
40	AC53EV0ZV07	UPPER CORD STORAGE HOOK	1	
41	AMC76N-F70	SPRING (CORD HOOK)	1	
42	AMC58B-F70	WASHER (CORD HOOK)	1	SHIPPED 10 PER PACKAGE
43	AC50BDEVZV07	HANDLE GRIP	1	
44	AXTN4+30BFY	SCREW (HOSE HOLDER)	1	SHIPPED 10 PER PACKAGE
45	AXTN4+45BFY	SCREW (CORD HOOK)	1	SHIPPED 10 PER PACKAGE
46	AXTN4+10FFY	SCREW TAPTITE		SHIPPED 10 PER PACKAGE
47	AC25SBSKZ000	FLANGE	1	
48	AC21HDRVZ000	WINDOW	1	
49	AMC37G-V200U	WIRE CORD	1	
50	AC44DCYKZ000	WIRE CRIMP		
51	AC60KDEXZR03	DUST COVER	1	
52	AC01DDEVZV07	LATCH	1	
53	AC23DDEVZ000	SPRING	1	
54	AC39AYUZV00	PACKING (RIGHT)	1	
55	AC40AYUZV00	PACKING (LEFT)	1	
56	AC88RYUZV06	DUSTING BRUSH	1	
57	AC60RZFZV06	CREVICE TOOL	1	
58	AC40PJPZV06	WAND (WITH TABS)	1	
59	AC40PZG1V06	WAND (EXTENSION)	1	
60	AC93HDDWZ000	BULB SOCKET	1	
61	AC28GBKHZ000	BULB LIGHT	1	
62	AC83DDAAZU00	LOCKING CAM	1	
63	AXTS3+12KFYY	SCREW LOCKING CAM	1	
64	AC98MRFZ000	INDICATOR ASSEMBLY COMPLETE	1	
65	AXTN4+10BFY	SCREW INDICATOR	2	
66	AC19ADHKZ000	BODY PACKING	2	

2.2. Nozzle Housing

2.2.1. Exploded View

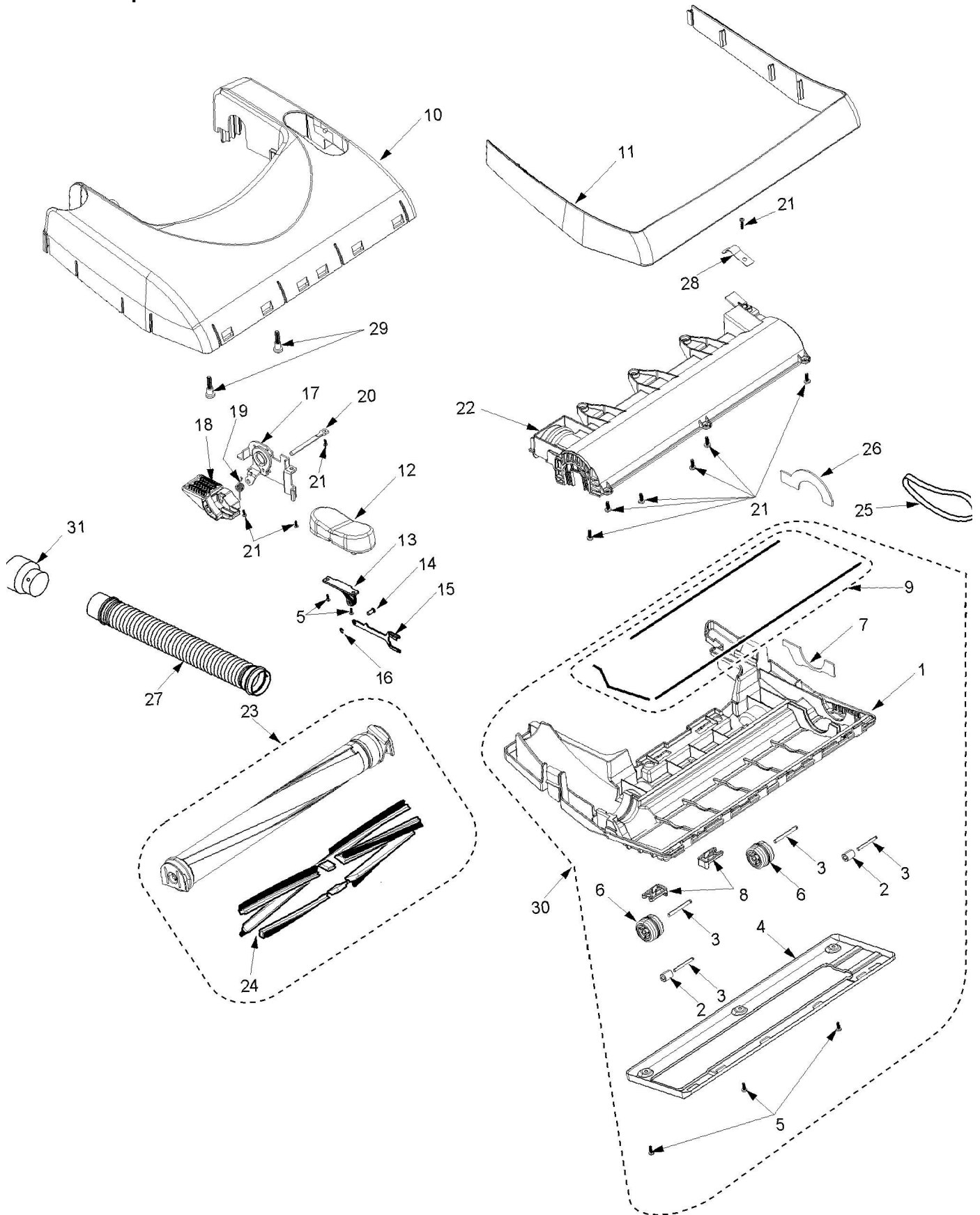

2.2.2. Parts List (Nozzle Housing)

Ref. No.	Part No.	Part Name & Description	Quantity	Remarks
1	AC97ADDWZV07	LOWER BODY UNIT	1	
2	AC01CDDWZV07	WHEEL	2	
3	AC16CNXZ00	ROLLER SHAFT	4	
4	AC27ADDWZ000	LOWER PLATE	1	
5	AXTN4+10BFY	SCREW	5	SHIPPED 10 PER PACKAGE
6	AC99QCYBZV06	WHEEL UNIT	2	
7	AC11ADDXZ000	FELT (LOWER)	1	
8	AC68NCYZZV06	LATCH	2	
9	AC19ADDWZ000	BODY PACKING	1	
10	AC01ADKXZR03	BODY NOZZLE HOUSING (DECO)	1	
11	AC10ADDWZV07	FURNITURE GUARD	1	
12	AC70QDDWZV07	FOOT PEDAL	1	
13	AC16UDDWZV07	SHIFT LEVER	1	
14	AC55VDDWZV07	CONNECTOR PIN	1	
15	AC10DDWZ000	SLIDE PIECE	1	
16	AC23FBVNZ000	RING CLIP	1	
17	AC43AAFYZ00	BRACKET	1	
18	AC47ADAAZM0E	PEDAL	1	
19	AC58AAFVZ00	PEDAL SPRING	1	
20	AMC51A-YUZ0000	PEDAL SHAFT	1	
21	AXTN4+16BFY	SCREW	10	SHIPPED 10 PER PACKAGE
22	AC02ADDWZV07	UPPER BODY	1	
23	AC92SDDWZ000	AGITATOR ASSEMBLY	1	
24	AC85RDDWZU01	BRUSH UNIT	6	
25	AC28SCZFPZ000	BELT	1	
26	AC11ADDWZ000	FELT (UPPER)	1	
27	AC34PDDEZV06	NOZZLE HOSE	1	
28	AC76SDDWZ000	LEVER SUPPORT SPRING	1	
29	AMC68A-V30	SCREW	2	
30	AC91ADDWZV07	LOWER PLATE UNIT	1	
31	AC29QDKVZV06	HOSE PLUG B	1	